

## Crane Spare Parts Brochure



Eurocrane delivers safe, efficient and user-friendly material handling solution



 **EUROCRANE**





# Eurocrane

## World-renowned manufacturer and service provider of cranes and material handling products

As a well-known professional manufacturer and service provider of cranes and material handling products, Eurocrane, dedicated to the development and research of crane and material handling technology and focusing its business on the R & D, design, manufacturing, installation and services of high-end equipment, offers full lifecycle services for its products and relentlessly pursues industrial progress to elevate industrial development by insisting on innovation, adapting to new concepts and developing new products.

Eurocrane mainly has such business units as cranes, electric hoists, transmission equipment and engineering machinery components. The producing lines are well designed to deliver qualified products with excellent performance. The company has achieved a breakthrough in specific technologies and owns the abilities to manufacture core parts. The products have spread throughout the world, including more than 50 countries and regions and have found extensive applications in 20-plus professional fields like high-end equipment manufacturing, transportation and logistics, paper-making, energy and power, automobiles and ships, metal processing, aeronautics and astronautics, etc. The company offers services for more than 5,000 medium- and high-end customers all over the world.

## Persist in R&D with Intelligence Focus

Eurocrane has been committed to continual innovation in technology, products, solutions and business operations based on customer needs, playing a vital role in exploring the intelligent material handling market.

With more than 100 patents, Eurocrane has been certified as a hi-tech enterprise in Jiangsu province, and dedicated to advancing the industry to upgrade and transform to automation and intelligence.

## Eurocrane's Core Competence Based on Quality Assurance

With A-grade special equipment manufacturing license and A-grade installation, transformation and maintenance license issued by the General Administration of Quality Supervision, Inspection and Quarantine of PRC, ISO9001 quality management system certificate and ISO14001 environmental management system certificate issued by TÜV Rheinland, and EU CE certificate, Eurocrane provides customized solutions with lifting tonnage from 60kg to 600,000kg. Featuring light weight, high safety & reliability, optimal performance, and energy efficiency, these products help customers save plant construction investment, improve productivity, reduce energy use and daily operating cost, resulting in high return on investment.

## Full Lifecycle Services and Integrated Material Handling Solutions

With strict and effective quality management system, a dedicated project management team, and one-stop pre-sales, in-sales and post-sales turnkey service, Eurocrane delivers safe, efficient, user-friendly material handling solutions for leading enterprises across China, winning recognition from customers, including leaders in more than 20 industries.

## Global Perspective from China

Attaching great importance to emerging markets and the core value of overseas industrial chains, Eurocrane has established a global sales and service network through its overseas branches and partners to cover global market. Our overseas footprint has extended to more than 50 countries and regions.



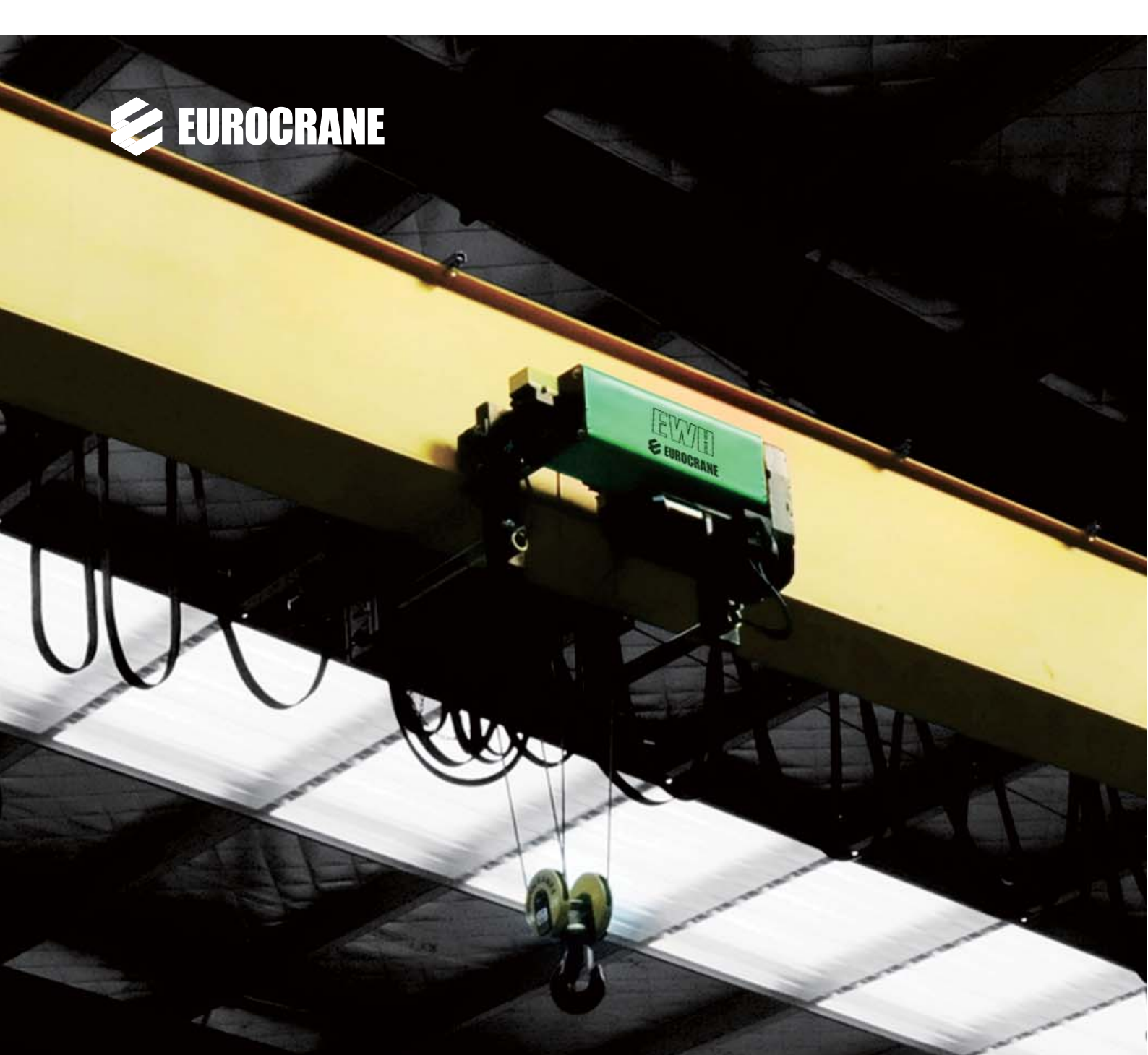

Eurocrane With Extensive Industry Experience Develop Kinds Of Patented EWH Series Hoist From The Customer'S Need And Concept Of Modular Design. It Adopts C-Shaped Design With Characteristic Of Compact Structure, Stable Operation And Precise Positioning. EWH Wire Rope Electric Hoists Are Always Highly Praised Due To The Application Of Many New Technologies, Such As Inverter Control, Braking Energy Feedback And Safety Monitoring System. EWH Electric Wire Rope Hoist Can Provide You With Better Logistics Solutions To Ensure The Reliability And Safety Of Equipment Operation.

## EWH Series Wire Rope Hoist



EWH Single Girder Electric Wire Rope Hoist



EWH Double Girder Electric Wire Rope Hoist



**Lifting Motor**



**Brake**



**Brake**



**Rope Guide**



**Rectifier Module**

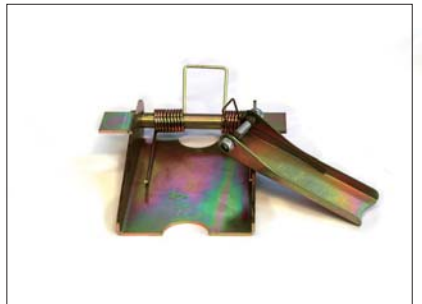

**Safety Latch**



**Sheave**



**Friction Plate**



**Fan Casing**



**Sheave Cover**



**Hook Block**

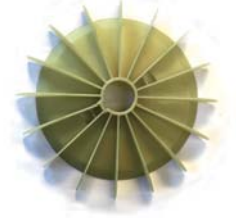

**Fan**



**Drum**

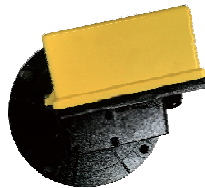

**Lifting Limit Switch**



**Invertor**



**Fall block limit switch**



**Transformer**



**Drum Support**



When Using The Equipment, You May Be Unable To Purchase Parts In Time Or The Manufacturer Cannot Provide Parts If Equipment Shutdown. However Headquarter Of Eurocrane And Its Spare Parts Depots Are Prepared With Sufficient, High-Quality And Guaranteed Spare Parts, Which Improve The Customer Equipment Utilization Without Worries.





**Multi-Pole Current Collector**



**Unipolar Current Collector**



**Flexible Beam Trolley**



**Cable Pulley**



**Spreader**

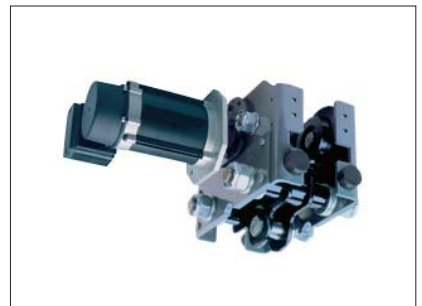

**Electric Suspension Trolley**



**Wheel Set**

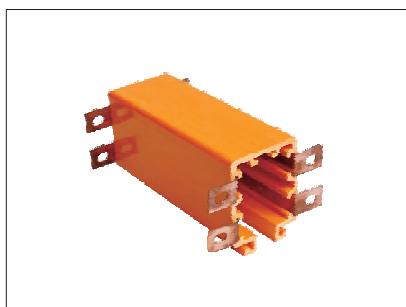

**Busbar System**



**Cabin**

Eurocrane provides you with high-quality spare parts at home and abroad. Hotline: 400-117-6999 or 0512-82072666-8033



Eurocrane is a world-renowned manufacturer and service provider of cranes and material handling products operating across all industries whose business presence spans more than 50 countries and regions. With an outstanding design team, we offer complete pre-sales and after-sales services. Our complete lines of crane solutions are widely recognized by customers, and help them improve efficiency and create value.

**Sales Hotline-400 117 6888**

**Service Hotline-400 117 6999**

**Eurocrane (China) Co., Ltd.**

No.288-388, Fen Yue Road, Foho New & Hi-Tech Industrial  
Development Zone, Suzhou, Jiangsu ,China (215211)

Tel:+86-0512-8207 2666 Fax:+86-0512-8207 2999

Email:contact@eurocrane.com.cn

www.eurocranegroup.com

---

EC-SP-EN-01

Eurocrane retain the right of changing the product's design and specifications any time; when procurement and delivery, please refer to the actual product.