



VANSON ELECTRONICS LTD.

TEL: (852) 24271 741

19, FL., KINGSWAY INDUSTRIAL BLDG.,
FLAT "H", 173-175 WO YI HOP RD.,
KWAI CHUNG, N.T., KOWLOON,
HONG KONG

Email: vanson@asiansources.com
Fax: (852) 2480 5640

Your Ref.

Our Ref.

Hong Kong, November 5, 2009

Page: 1 of 2

PRODUCT SPECIFICATIONS

Description:	VA2524 ~ 60W Boost Adapter (DC / DC Adaptor)
Model No.:	SDR-70W024
Primary Voltage and Frequency:	11-14V DC 8A max.
Secondary voltage:	24V DC \pm 10% 2.9A Max. 70 Watt
DC Plug (Input):	30cm of UL1185 AWG18 cord with cigarette lighter input plug
DC Plug (Output):	Female plug 5.5x2.5x10mm straight type with 1.3M of UL1185 AWG18 cable
Dimensions:	90mm(L) x 57.4mm(W) x 30mm(H) \pm 0.5mm (not include cord)
Weight:	217 grams \pm 1g
Polarity:	Centre Positive
Fuse:	10A (Slow blow)

TESTING CIRCUIT ON OUTPUT:

Power Indicator: 3mm (Green)

A = Amperemeter

V = Voltmeter

R = Variable resistor

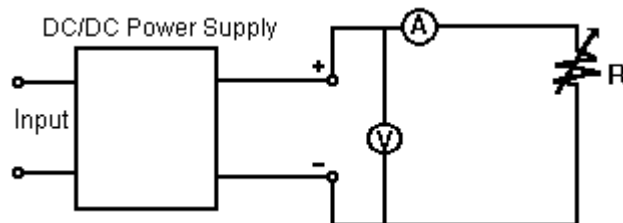

Tested By: ZAG

Approved By:



VANSON ELECTRONICS LTD.

TEL: (852) 24271 741

19, FL., KINGSWAY INDUSTRIAL BLDG.,
FLAT "H", 173-175 WO YI HOP RD.,
KWAI CHUNG, N.T., KOWLOON,
HONG KONG

Email: vanson@asiansources.com
Fax: (852) 2480 5640

Your Ref.

Our Ref.

Hong Kong, November 5, 2009

Page: 2 of 2

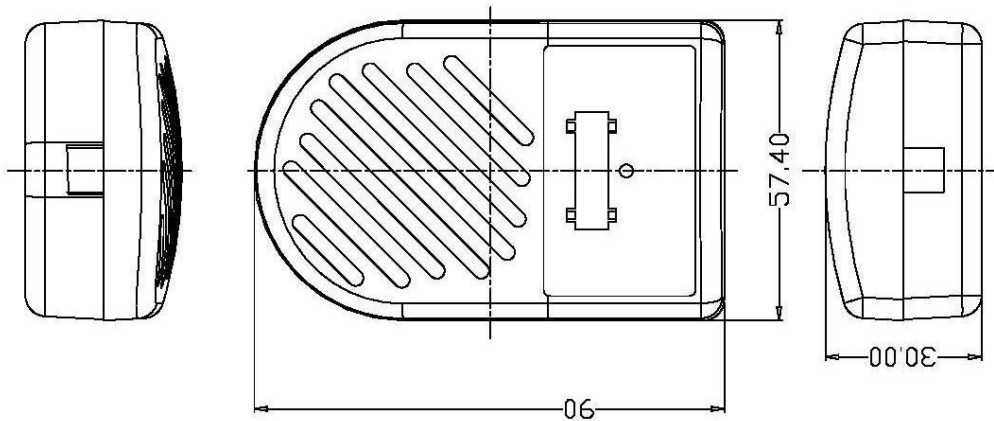
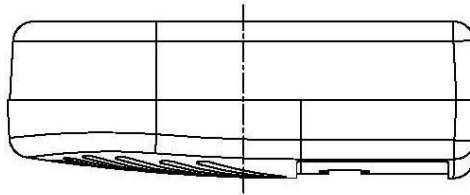
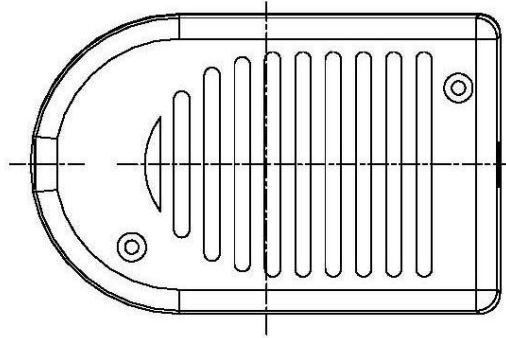

Tested By: ZAG

Approved By: 