



9550 Roll-Up Door Installation Guide

SteelBlue Building Components 6600 Steubenville Pike
One Robinson Plaza - Suite 240 Pittsburgh, PA 15205

Phone 412.857.496
www.steelbluebc.com

Initial Release | 10.17.2025



Important Safety Information

- ✦ Carefully read installation instruction, familiarize yourself with all installation procedures, warnings, cautions, and notes before attempting to install door.
- ✦ Inspect received door assembly for visible damage and/or component shortages.
 - A. Shipping damage: file damage claim immediately with freight carrier, supply door supplier with photo documentation to receive replacement components.
 - B. Part shortage: immediately contact door supplier with parts shortage claim, order number, door model and photo documentation are encouraged to expedite process.
 - C. Incorrect parts: if received door components and parts do not match those referenced in these installation instructions, immediately contact door supplier.
- ✦ If, at any time before or during installation, you are unfamiliar, uncomfortable, or confused by the installation procedures outlined in these instructions, do not attempt to install door assembly; immediately contact the door supplier with questions/concerns.

✦ SteelBlue Building Components doors must be installed by trained rolling door technicians qualified to install product safely with proper knowledge, tools, safety and installation equipment.

Read All Warnings Below

- ✦ Use appropriate safety equipment to avoid serious injury.
 - ✦ Clear floor at opening of all debris before installing product.
 - ✦ Use appropriate lifting equipment and correct lifting procedures to avoid damage, serious injury or death.
 - ✦ Moving door could result in death or serious injury.
 - ✦ Do not close door until doorway is clear.
 - ✦ Control the speed of the door during manual operation.
 - ✦ Do not stand or walk under a moving door.
 - ✦ Keep doorway clear and in full view while operating door.
 - ✦ Do not permit children to play on, near, with door or operate door controls.
 - ✦ Unlock door before opening door.
 - ✦ Sensing devices on motor operating doors should be tested at least weekly.
 - ✦ Visually inspect door and hardware monthly for worn and/or broken parts and check if door operates freely. Do not operate a door with a broken spring(s).
 - ✦ Components are under extreme spring tension and could result in death or serious injury. Door must be fully opened when making adjustments.
- Retain these instructions for reference.
- These instructions as well as operation & maintenance manual are available via pdf download at www.steelbluebc.com or upon request.

Important Information

✦ SteelBlue Building Components doors must be installed by trained rolling door technicians qualified to install product safely with proper knowledge, tools, safety, and installation equipment. Carefully read installation instructions, familiarize yourself with all installation procedures, warnings, cautions and notes before attempting to install door. SteelBlue Building Components will not warranty or accept responsibility for doors not installed per these installation instructions.

Handle with Care - do's & don'ts

DO's

- ✔ Carefully inspect all product for damage upon receipt.
- ✔ Use protective foam between product and surface or any object it may come into contact with while in transit, storage and/or installation.
- ✔ Carefully unload product from any type of crating material assuring no contact with fasteners or sharp edges.
- ✔ Clear floor at opening for debris before installing product.
- ✔ Single person lifting of product could cause injury. Use assistance when moving or lifting.
- ✔ Install product with appropriate lifting equipment.

DON'Ts

- ✘ **Do not** – stand on product.
- ✘ **Do not** – climb on product.
- ✘ **Do not** – walk on product.
- ✘ **Do not** – throw or toss product.
- ✘ **Do not** – allow sharp objects to come in contact with product.
- ✘ **Do not** – leave product unsecured while in transit or during installation.

✦ Failure to adhere to the above conditions will result in personal injury or product damage not covered under SteelBlue Building Components product warranty. Always handle product with care and review all instructions, warnings and notes before installing product.

✦ Review door assembly and general parts descriptions bill of material from page 4, figure 1 to familiarize yourself with common parts of rolling sheet door assembly.

✦ Door assemblies are manufactured per opening widths and heights specified at time of order. SteelBlue Building Components will not be held responsible for opening widths and heights that do not match those specified at time of order.

Door Assembly & General Part Descriptions

9550 Series

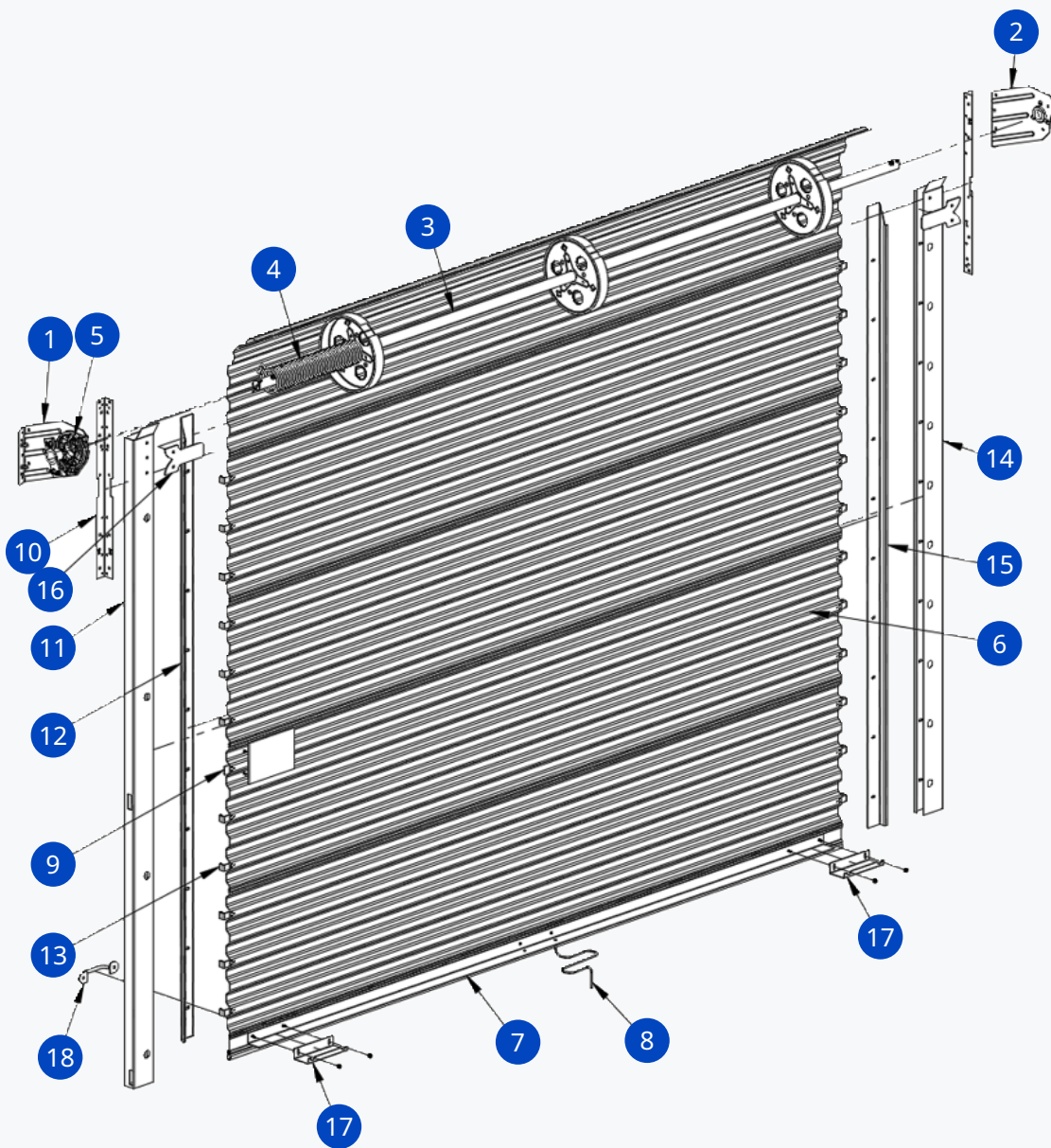

Operation & Maintenance Manual available via pdf download @ www.steelbluebc.com or upon request

figure 1

General Bill of Materials

Item	Description	Item	Description	Item	Description
1	Bracket-L	7	Bottom Bar/Astragal Assembly	13	J-Clip
2	Bracket-R	8	Rope	14	RH Guide
3	Ø1-5/16" O.D. AXLE	9	Mini Latch	15	RH Wind Bar
4	Spring/Counterbalance Assembly	10	Ext. Bracket Angle	16	Comm. Head Stop
5	Tensioner Assembly	11	LH Guide	17	Step Plate
6	26 Ga. Curtain	12	LH Wind Bar	18	Handle(s)

Headroom/Sideroom Dimensional References

Headroom Requirement

Opening Height	Vertical Headroom	Horizontal Headroom
Thru 7' - 4"	16"	16"
Over 7' - 4" Thru 8' - 8"	16 - 1/2"	16 - 1/2"
Over 8' - 8" Thru 10' - 0"	17 - 1/2"	17 - 1/2"

figure 2: Headroom Requirement

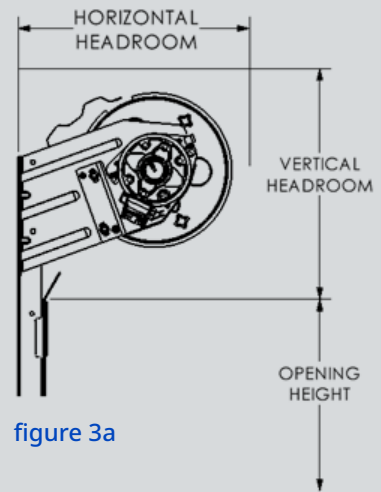

figure 3a

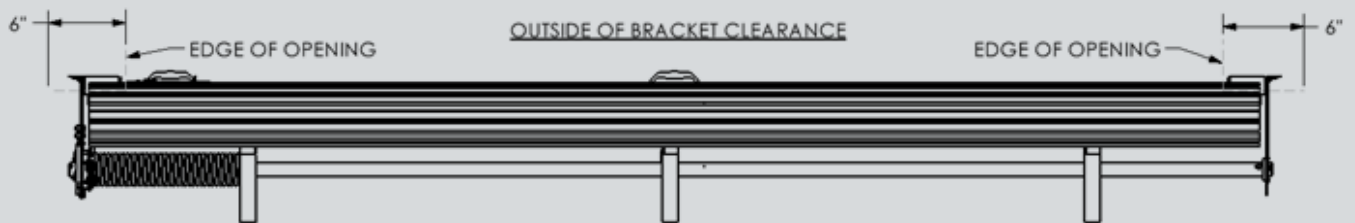

figure 3b

Important notes

- ◆ Dimensions are referenced from edge of the door opening
- ◆ For critical fits due to reduced available headroom or sideroom, consult factory
- ◆ To properly secure the brackets, there needs to be approximately 6" of sideroom clearance on both sides in order to access mounting holes

Step 1: Verify Opening

- ✦ Verify wall opening width and height. Verify these measurements against the size detailed on door package label.
- ✦ Verify the jambs are plumb.
- ✦ Check the floor and header are level.
- ✦ Verify adequate side clearance at jambs and headroom clearance above and at sides of header. Check horizontal and vertical headroom requirements. See page 5, Figure 2 & 3.
- ✦ Verify that the guide mounting surface on the jamb is flush.
- ✦ Make sure all parts required for installation are with the door. See page 4, Figure 1 for General Bill of Material

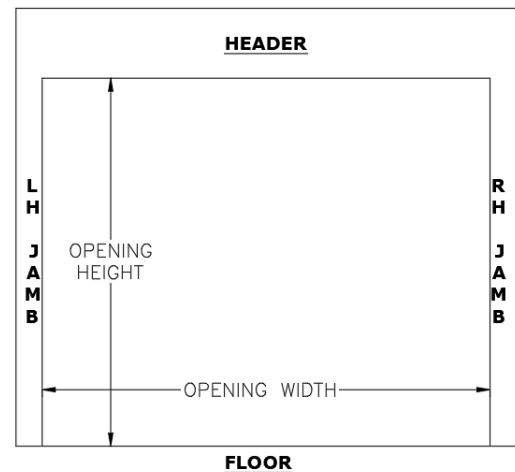

Step 2: Position Door & Parts

- ✦ Verify floor area is clean in order to prevent damage to curtain.
- ✦ Inside of unit place left guide on floor perpendicular to opening with guide bottom closest to the left jamb and the top toward inside of building. Repeat step for the right guide.
- ✦ Place door on floor at the top of and between guides. Rotate door as necessary to locate bottom bar against floor. See Figure 4 below.
- ✦ Distribute hardware parts to the appropriate areas.

figure 4: Position Door & Parts

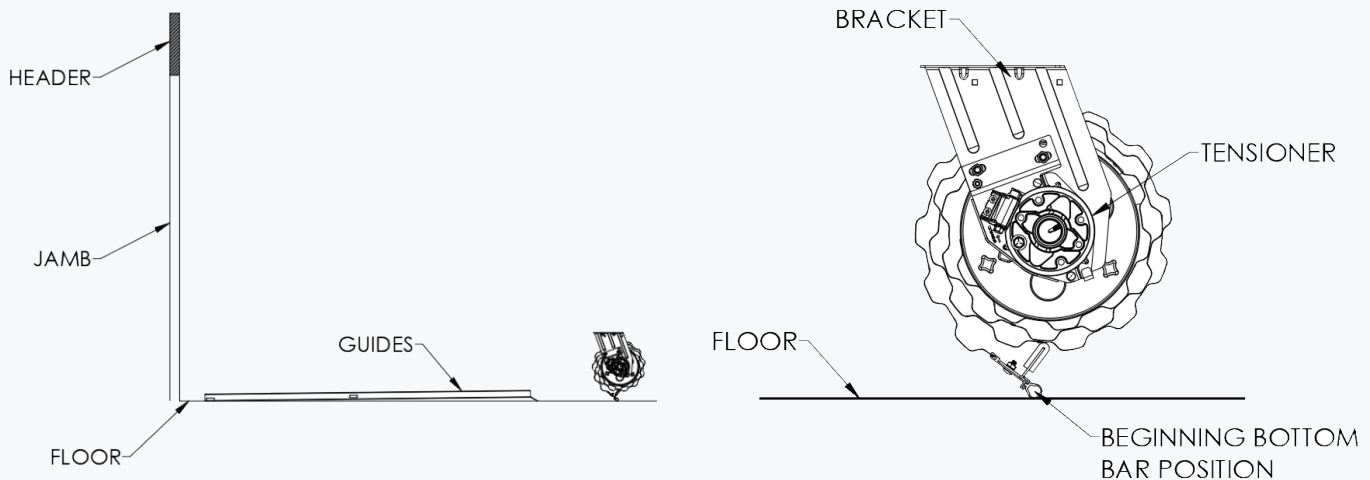

Step 3: Guides to Bracket Positioning - Bolt-On Bracket & Angle Installation

- ✦ Measure from the top of the guide down 14-1/4" and place a mark.
- ✦ For doors up to 8'-8" tall, place bracket angle on guide as shown with the word "EXT" towards the bottom, aligning bottom with mark. For doors taller than 8'-8", install the angle with the word "EXT" towards the top as extended brackets will be provided for proper installation.
- ✦ Align the faces shown, and clamp angle to guide.
- ✦ Using a 3/8" drill bit, drill thru the hole at the bottom and closest to the top of the guide in the angle, thru the guide.
- ✦ Attach angle to guide using two (2) each 1/4-20 x 5/8" carriage bolts and 1/4-20 keps nuts. See Figure 5.
- ✦ Attach bracket to guide using two (2) each 1/4-20 x 5/8" carriage bolts and 1/4-20 keps nuts. See Figure 5.
- ✦ Repeat for tensioner side.

Warning!

Door can fall if both brackets are not securely fastened to the jambs. All fasteners attaching brackets to jambs must fit securely into a structural member or surface. If door falls, serious injury or death and/or damage to the door can result.

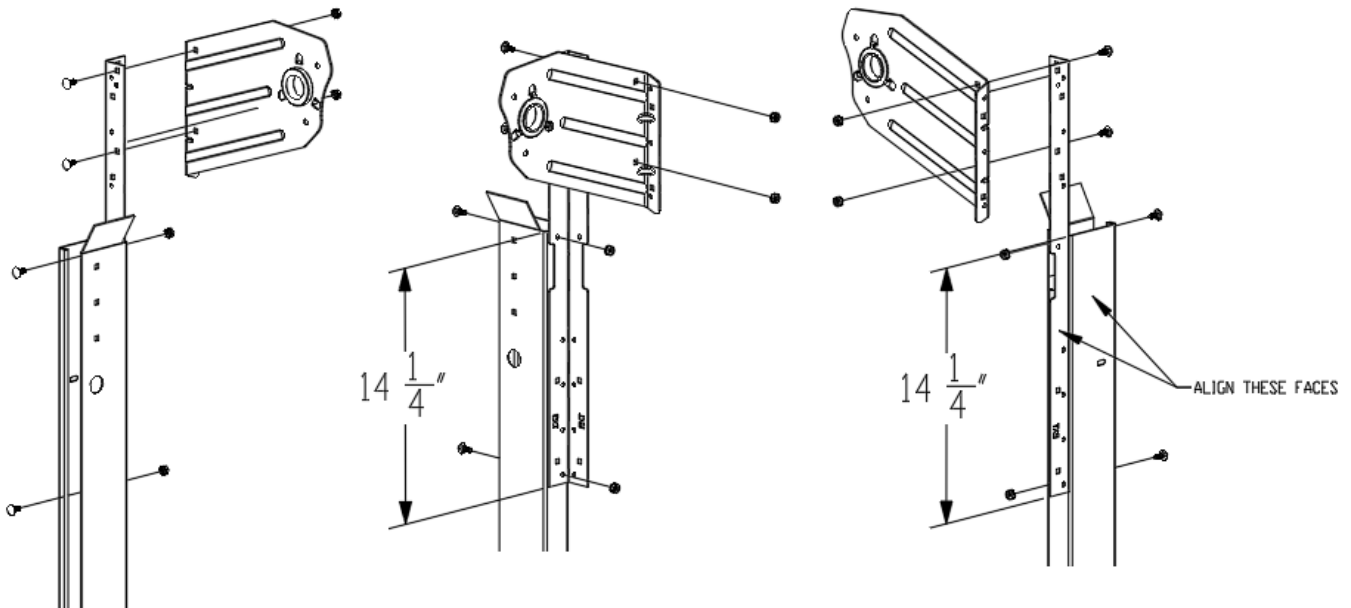

figure 5: Bolt-On Bracket

Step 4a: Bracket & Spring Attachment

- ✦ After the guides are attached to the brackets, install plastic sleeve on tensioner side and cotter pins in both ends of the axle.
- ✦ Reach into the rolled-up door and stretch spring over and hook on spring plate as shown. Ensure the guide on the spring plate goes inside the spring.
- ✦ On dual spring doors, attach the right-side spring to the right bracket with the supplied 5/16-18 x 1-1/4" bolt and nut prior to pre-tensioning the door. Ensure that the first coil of the spring is up against the bracket and sitting on top of the outer sleeve of the bearing.

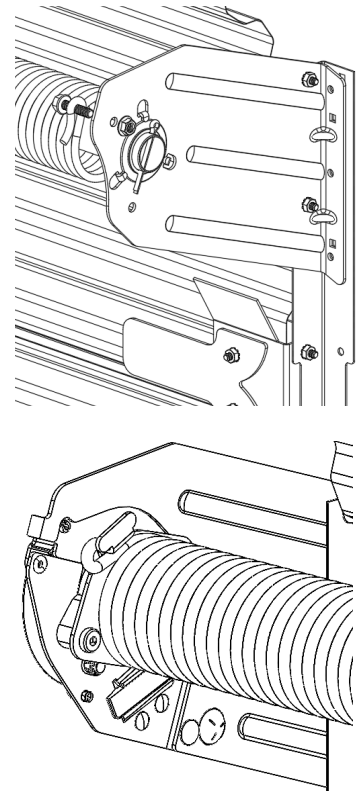
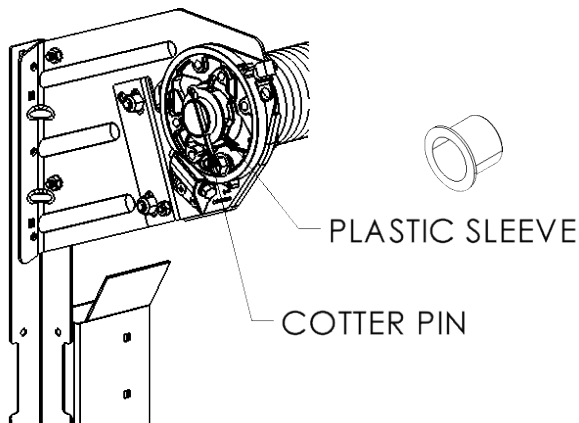

figure 6: Bracket & Spring Attachment

Step 4b: Lifting Door Assembly

- ✦ Move door and guide assemblies toward the wall opening with bottom of guides resting next to the jambs.
- ✦ Lift door assembly evenly, pivoting around bottom of the guides.
- ✦ Doors over 8'-0" high will require a mechanical lifting device to lift door and guides into mounting position.
- ✦ Any mechanical lifting device such as forklifts or genie lifts, must be padded to prevent curtain damage.

Warning!

Two installers are required to lift door assembly into position against jambs. The guides are not designed to support the door weight during a one-man installation. Attempting installation with only one installer can result in serious injury and/or damage to door. Do not leave door unattended until it is securely attached to jambs.

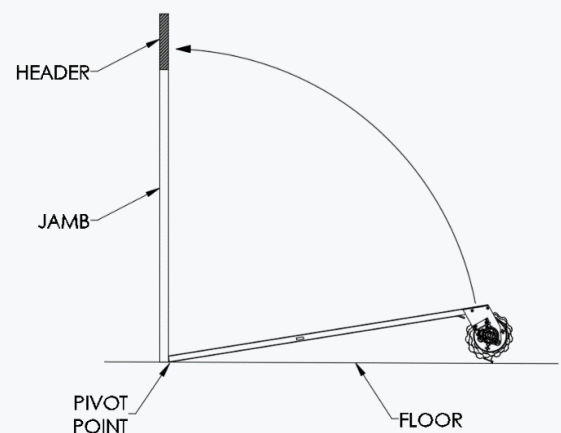

Step 4c: Securing Guides & Brackets to Jamb

- ✦ The door should be centered on the opening. Insert the corresponding wind bar into each guide then position top of guides 1/4-3/8" outward from frame (door opening) then install appropriate fastener from Table 1 in bottom hole of bracket, kick bottom of guide inward until top of bracket slants outward, then install fastener in top of bracket. Move bottom of the guide back out and make flush with frame. See Figure 7 & 7a. Make sure door is level.
- ✦ Install the remaining fasteners in the guides and brackets ensuring the wind bars are pulled as far inward as possible.
- ✦ Ensure wind locks and wind bar are properly positioned before rolling the door down. See Figure 7a.

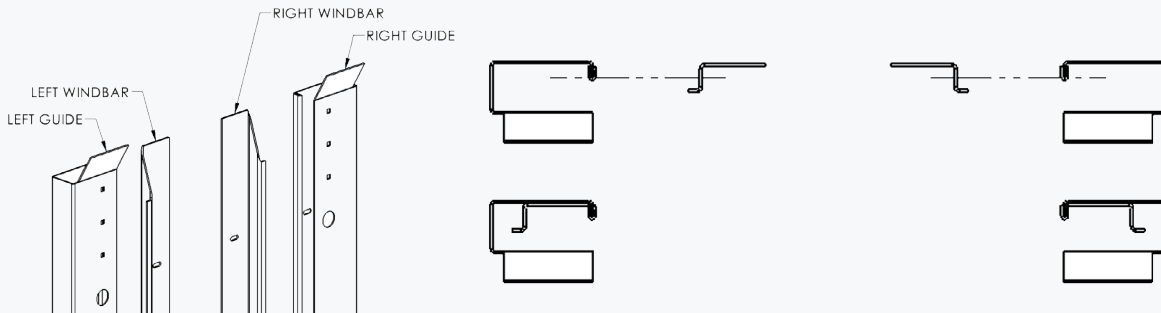

figure 7: Wind bar insertion into guide

Table 1: wall fasteners included for jamb attachment of brackets & guides

Item	Jamb	Fasteners	Drill size
Brackets and Guides	Concrete/Masonry	1/4" x 2-1/4" DeWalt Screw Bolt+	1/4" x 2-1/2" SDS
Brackets and Guides	Steel Structure	#12-14 x 1-1/4" Flange Tri-Seal Screw	None
Brackets and Guides	Wood	#14-10 x 1-1/2" Slotted Tap Screw	None

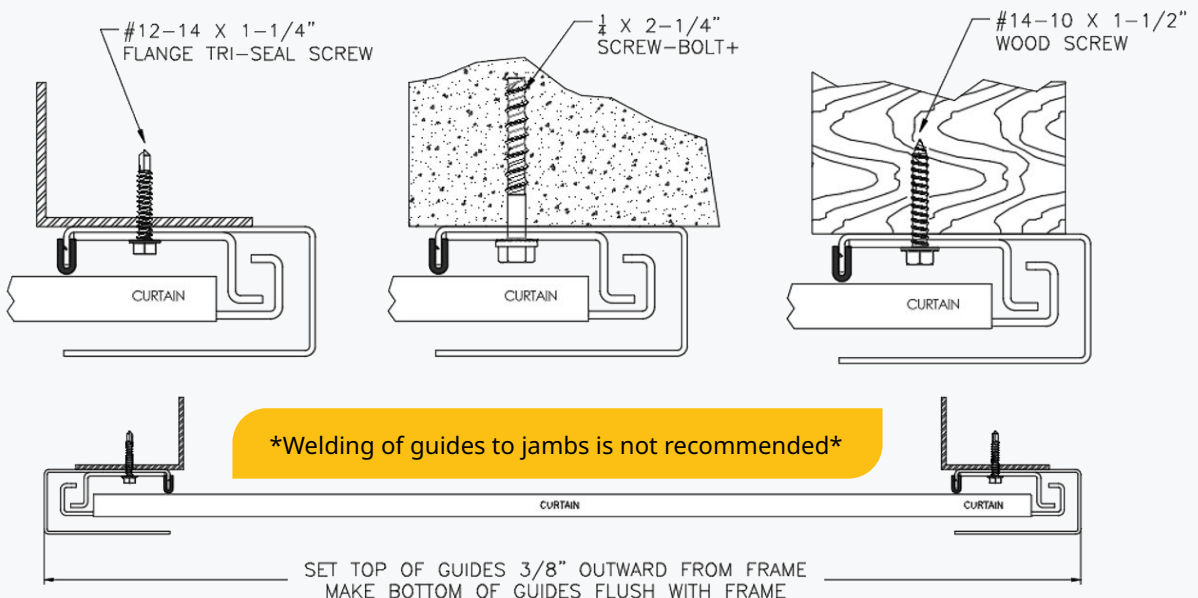

figure 7a: Outside of guide to outside of guide

Step 5: Setting Initial Spring Tension

- ✦ Before applying initial spring tension, assure the spring hook is securely attached to the spring plate. See Figure 6 above for visual reference.
- ✦ Rotate door two (2) revolutions in the direction that would send the bottom bar down through the guides. See Figure 8.
- ✦ While firmly holding the door at the bottom bar, cut the tape and plastic wrap that holds the door in a coil. Direct the bottom bar down into the guides stopping just past the head stop area and hold securely through completion of Step 6.

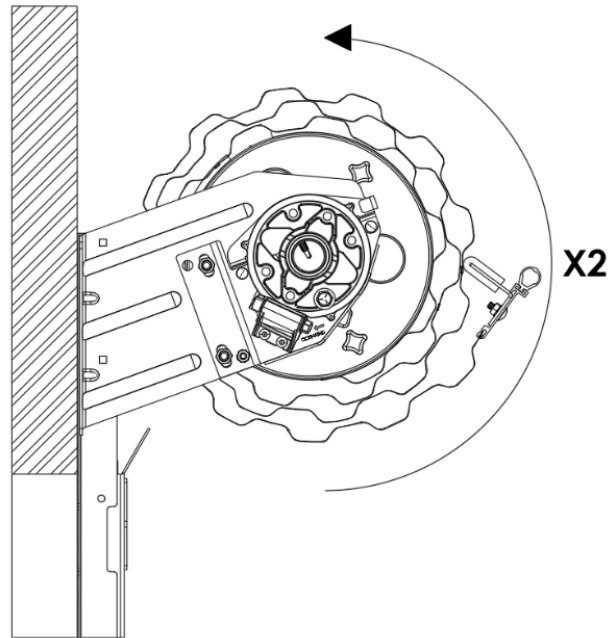

figure 8: Setting initial spring tension

Step 6: Head Stops

- ✦ Insert $\frac{1}{4}$ -20 x $\frac{5}{8}$ " carriage bolts thru inside of guide, place head stop on, then install the $\frac{1}{4}$ -20 keps nuts and tighten in desired position ensuring that there is no pinch point between handle and header when door is fully open. See Figure 9.

Warning!

Installation of head stops is required. Failure to properly install head stops will result in the door curtain to travel beyond the guides resulting in door damage and/or personal injury.

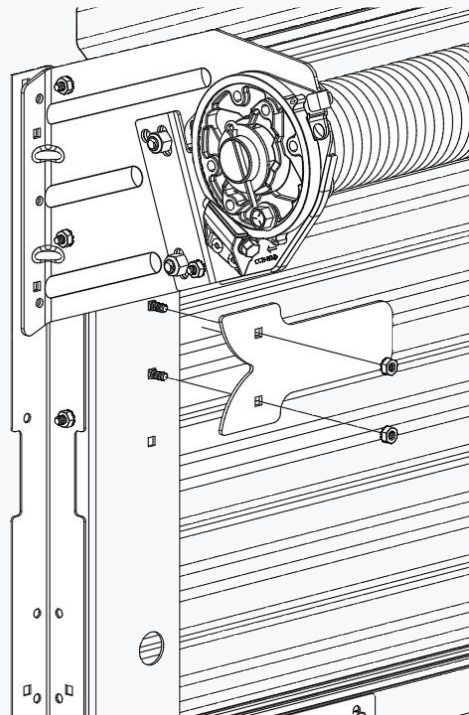

figure 9

Step 7: Handles

- ✦ Install handle(s) on outside of bottom bar using $\frac{1}{4}$ - 20 x $\frac{5}{8}$ " carriage bolts and keps nuts. See **Figure 10**.

✦ Note: for doors 6' wide and wider, two (2) handles will be provided for installation at center & latch side of bottom bar.

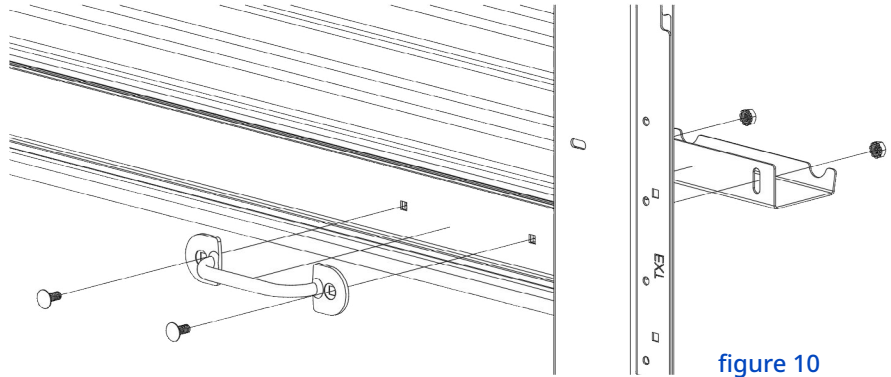

figure 10

Step 8: Check Door Operation

- ✦ Lower and raise the door to test door balance.
- ✦ If door is easy to close, but hard to open, increase spring tension. See **step 9**
- ✦ If door is hard to close, but easy to open, decrease spring tension. See **step 9**

✦ Note: manual adjustments of spring tension may be required. Adjustments are to be made using a $\frac{7}{16}$ " nut driver.

Step 9: Adjust Spring Tension

- ✦ Remove red safety bolt from tensioner with 7/16" nut driver.
- ✦ Test operation of door, if the door closes easy and is hard to open then turn the tensioner adjustment screw counterclockwise to add tension using 7/16" nut driver. If the door opens easy but is hard to close then turn the tensioner adjustment screw clockwise to remove tension using 7/16" nut driver.
- ✦ Test tension of door by rolling it up and down.
- ✦ Adjust tension as needed.
- ✦ Once tension is acceptable, with the door in the down position, locate the safety bolt slot opening on the inside of the tension (right above the adjustment screw). Then turn the adjustment screw either clockwise or counterclockwise in order to line up the closest bolt hole.
- ✦ Re-insert the red safety bolt with the 7/16" nut driver as shown in **Figure 11**.

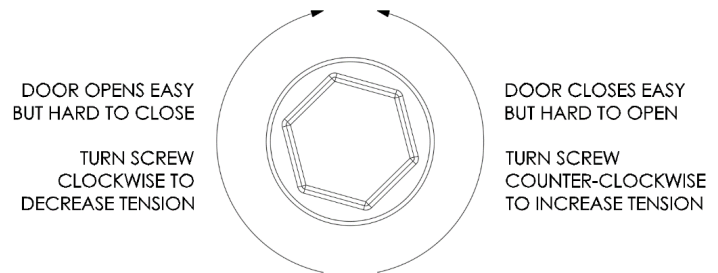
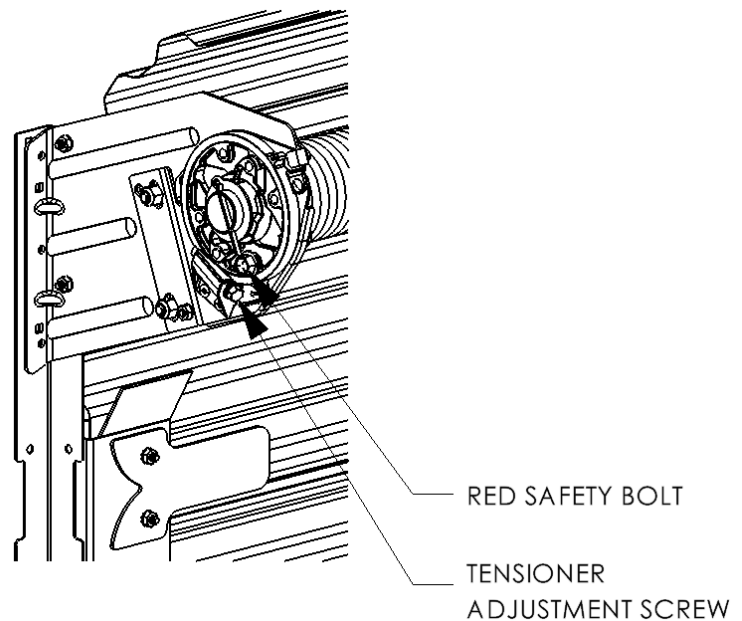

figure 11

Warning!

Components under extreme spring tension could result in death or serious injury. Adjustments must be made by trained rolling door technicians using proper tools. Door must be fully opened when making adjustments

Step 10: Product Safety Labels

- ✦ Visual ✓ for RDD-201 on tension bracket.
- ✦ Visual ✓ for RDD-204 on bottom bar.
- ✦ Install RDD-202 door drive side, guide, or jamb.

(See Page 15 for labels.)

✦ Note: SteelBlue Building Components requires these product safety labels to be in place and/or installed to fully complete installation.

Operation & Maintenance

The following manual is provided to evaluate the operational performance and future maintenance of SteelBlue Building Components Rolling Sheet door product line. SteelBlue Building Components mandates rolling sheet door product installation by trained rolling door technicians and future maintenance by experienced/qualified personnel. Specific parts, components, assemblies, etc. that are determined to be defective, worn, or unsafe by performance evaluations or preventative maintenance programs must result in rolling sheet door assembly taken out of service. All repairs, part replacements or adjustments must be made by trained rolling sheet door technicians to place rolling sheet door assembly back in service. It is **MANDATORY** that all SteelBlue Building Components door technicians and other technicians, installers and future maintenance staff comply with all safety information, procedures, and instructions contained in this manual. **Failure to do so could result in premature part/component failure resulting in serious injury or death to others** and, with respect to SteelBlue Building Components door technicians, immediate termination of employment.

Adjustments, part replacement, repairs, etc. must be performed by trained rolling door technician

Rolling Sheet Door Performance Evaluation

- ✦ Rolling Door operation should be easy at/near the open and closed positions. Rolling door may require more effort to open through the middle portion of travel.
- ✦ Rolling Door operation to the open position should result in bottom bar angle resting against the head stops and remain in the open position.
- ✦ Rolling Door operation should not exceed 35lb. of force for hand chain operation, and 30lb. for manual operation.
- ✦ Rolling Door operational balance evaluation:

If door operation is easy to close, but hard to open, spring tension needs to be increased

If door operation is hard to close, but easy to open, spring tension needs to be decreased

Spring tension adjustments must be made by trained rolling door technician. Refer to Rolling Door installation instructions for tension adjustment procedures.

Warning!

Extreme spring tension can cause serious injury or death



Visual Inspection

Guides

- ✦ Guide fasteners must be present and secured in each existing hole/slot provided with fasteners supplied by SteelBlue Building Components.
- ✦ Guides must not be bent, crushed, or damaged in a way that binds the curtain and/or bottom bar assembly at any portion of travel.
- ✦ Head stops must be securely fastened in place at top of guide to prevent bottom bar from traveling out of the top of the guides when rolling door curtain is fully raised to the open position.
- ✦ Inspect guide wear strip (when provided) for excessive cracking, tearing, wear or absence.

Brackets/Mounting Plates

- ✦ All fasteners must be present and installed per detailed installation instructions.
- ✦ Brackets & Mounting plates (when provided) must not be bent or damaged in a way that adversely effects the safe operation of the door assembly.

Hood Assembly

- ✦ When provided, all fasteners attaching hood endcaps, hood support (when provided) and hood to wall must be secure.
- ✦ Hood endcaps or hood must not be bent or crushed in a manner which binds the curtain thus hindering the proper operation of the rolling door operation.

Curtain

- ✦ During rolling door operation, curtain and bottom bar assembly must move freely inside guides and not contact header or ceiling.
- ✦ Latches, Handles, Slidelocks, Windlocks, etc. (when provided) must always be securely fastened to curtain assembly.
- ✦ **Windlocks should never be removed from curtain.**
- ✦ Inspect curtain wear material or rubber pads/strip (when provided) for excessive tearing, wear, or absence.
- ✦ Inspect weather seals, top draft stop, side draft stop, brush (when provided).

Tensioning Devices & Axle Supports

- ✦ Fasteners attaching all tensioning devices and axle supports must be securely fastened.
- ✦ Set screws securing axle must be securely fastened.
- ✦ Inspect components for damage or deformity.

- A. Determination of tensioning device repair or replacement must result in Rolling Door taken out of service until required repairs are completed. Repair or replacement must be performed by trained rolling door technician.
- B. Product safety labels should be periodically inspected and cleaned by the product user as necessary to maintain good legibility for safe viewing distance. Product safety labels should be replaced by the product user when they no longer meet the legibility requirements for safe viewing distance. In any case where products have an extensive expected life or where exposed to extreme conditions, the product user should immediately contact SteelBlue Building Components to obtain replacements.

Product Safety Labels

RDD-202 Rolling Door Safety Label

⚠ WARNING



Moving door could result in death or serious injury

Do NOT close door until doorway is clear

SAFETY INSTRUCTIONS

1. Control the speed of the door during manual operation.
2. Do not stand or walk under moving door.
3. Keep doorway clear and in full view while operating door.
4. Do NOT permit children to play on, near, or with door, or operate door controls.
5. Unlock door before opening door.
6. Sensing devices on motor operating doors should be tested frequently.
7. Adjustments or repairs must ONLY be made by a trained door systems technician using proper tools and instructions.
8. Visually inspect door and hardware monthly for worn and/or broken parts and check if door operates freely. DO NOT operate a door with a broken spring.

Place label at a readable height on door drive side guide or jamb.

Do NOT remove, cover, or paint over label.

This label should be inspected periodically for legibility, and a replacement label should be ordered from the door manufacturer as needed.



12/07
RDD-202 ©

RDD-201 Tension Safety Label

⚠ WARNING



Components under extreme spring tension could result in death or serious injury.

SAFETY INSTRUCTIONS

1. Repairs and adjustments must be made by a trained rolling door systems technician using the proper tools and instructions.
2. Door **must** be fully opened when making adjustments.



Do NOT remove, cover, or paint over label.

This label should be inspected periodically for legibility, and a replacement label should be ordered from the door manufacturer as needed.



12/07
RDD-201©

Order # _____

⚠ WARNING	SAFETY INSTRUCTIONS	<p>4. Do NOT permit children to play on, near, or with door, or operate door controls.</p> <p>5. Unlock door before opening door.</p> <p>6. Sensing devices on motor operated doors should be tested frequently.</p>	<p>7. Adjustments or repairs must ONLY be made by a trained door systems technician using proper tools and instructions.</p> <p>8. Visually inspect door and hardware monthly for worn and/or broken parts and check if door operates freely. DO NOT operate a door with a broken spring.</p>	<p>Attach label to bottom bar. Do NOT remove, cover, or paint over label.</p> <p>This label should be inspected periodically for legibility, and a replacement label should be ordered from the door manufacturer as needed.</p>	
 <p>Moving door could result in death or serious injury.</p> <p>Do NOT close door until doorway is clear.</p>	<ol style="list-style-type: none"> 1. Control the speed of the door while manually operating. 2. Do not stand or walk under moving door. 3. Keep doorway clear and in full view while operating door. 				12/07 RDD-204 ©

RDD-204 Rolling Door Bottom Bar Label

- ✦ SteelBlue Building Components requires the following product safety labels to be in place and/or installed to fully complete installation.
- ✦ Any case where product safety labels are missing or damaged, contact SteelBlue Building Components immediately to obtain replacements.



SteelBlue Building Components 6600 Steubenville Pike
One Robinson Plaza – Suite 240 Pittsburgh, PA 15205

Phone 412.857.3496
www.steelbluebc.com

Initial Release | 10.17.2025