

COMB GENERATOR

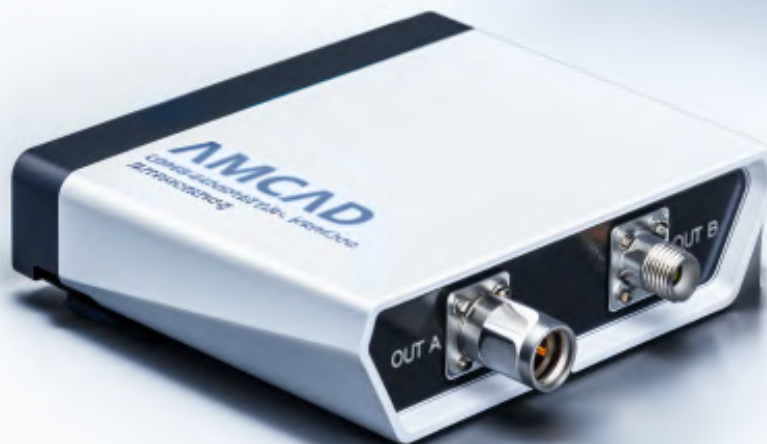

www.amcad-mw.com

MAIN FEATURES :

- **Broadband Input:** 10 MHz to 7 GHz.
- **External Synthesizer Compatible:** Works with external signal generators.
- **Dual Outputs:** Two differential comb generator outputs.
- **Time-Domain Calibration:** Provides CAL and REF for accurate RF measurements.
- **Single Mode:** Operates with output 2 terminated by a 50Q load.
- **Flat Amplitude:** Consistent amplitude across the frequency range.
- **NIST Calibration:** Calibrated using a 10 MHz input, NIST traceable.
- **Wideband Harmonics:** Outputs from 10 MHz to 26.5 GHz.
- **Stable & Repeatable:** Ensures reliable signal performance.
- **Connectors:** Super SMA input, 2.92mm male/female outputs.
- **USB Powered:** 5V DC / 200mA.



The comb generator provides harmonic signals with a fixed and known phase relationship between each tone.

	Minimum	Maximum
Input signal		
Frequency	10 MHz	7GHz
Peak -to -peak Level	0,2 Vpp	3,4V pp
Absolute level	-3,8V	+3,8V
Output signal @10MHz Input		
Power @ [10MHz ; 7GHz]	-68 dBm	
Power @ [7GHz ; 20GHz]	-83 dBm	
Power @ [20GHz ; 26.5GHz]	-99 dBm	

This wideband signal can be used for different applications

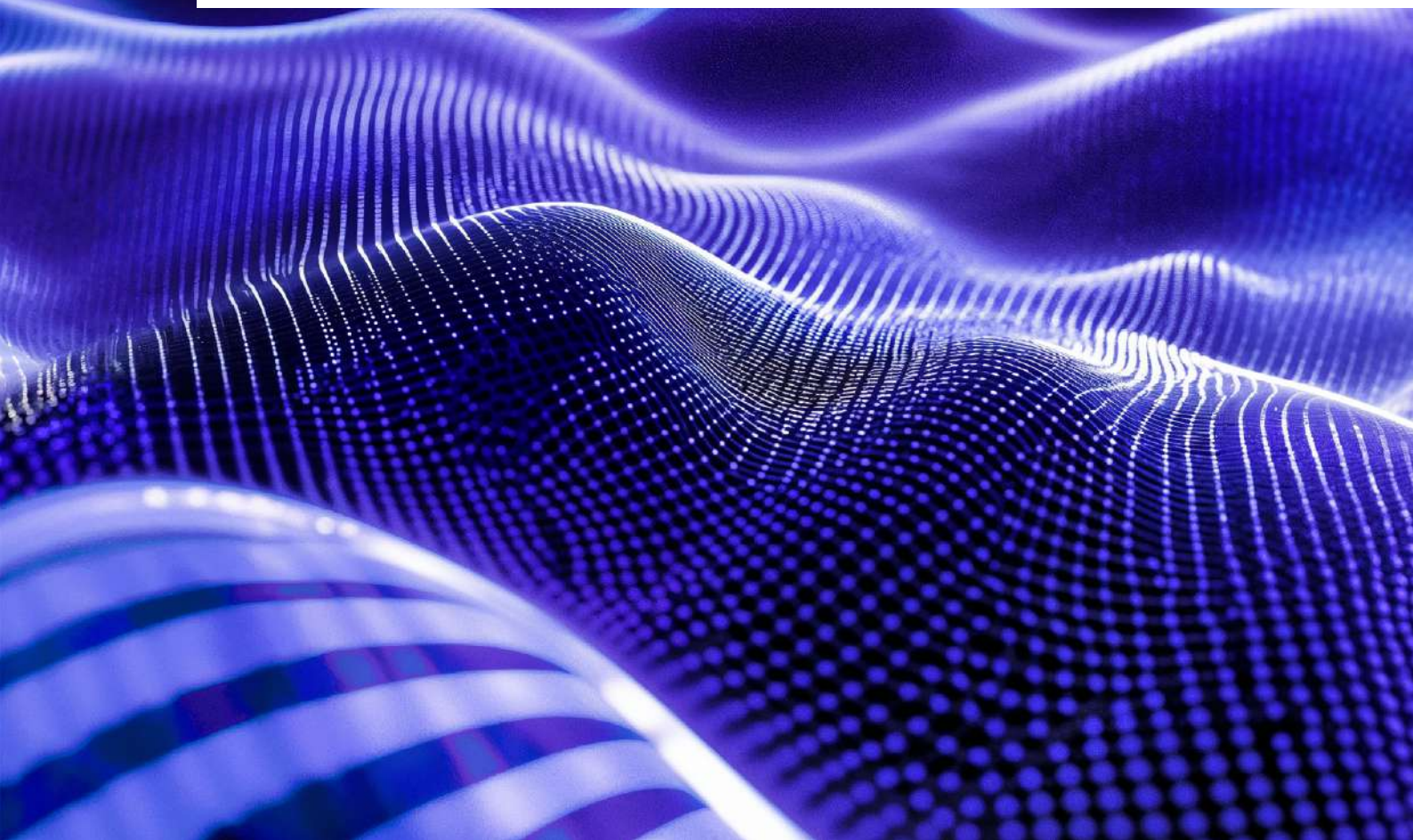

APPLICATIONS EXAMPLES

- **RF Transistor Modeling** : Enhanced Poly-Harmonic Distortion (EPHD) behavioral modeling for precision RF design.
- **EMC/EMI Testing** : Reliable reference for site calibration, reducing setup errors.
- **Waveform Engineering** : Time-domain load pull measurements for improved amplifier efficiency.

Application example 1

Large Signal Analysis & Waveform Engineering

AMCAD wideband comb generator has been developed for the characterization of nonlinear RF devices (transistors, amplifiers), enabling the measurements of absolute phase of the harmonic content of a signal and allowing Waveform engineering capabilities in time-domain Load-Pull.

Waveform engineering can be used to minimize the power consumption and to optimize the power added efficiency of amplifiers, operating in a switch mode class of operation like Class F or inverse Class F.

[See IVCAD MT930GA Large Signal Analyzer operating manual](#)

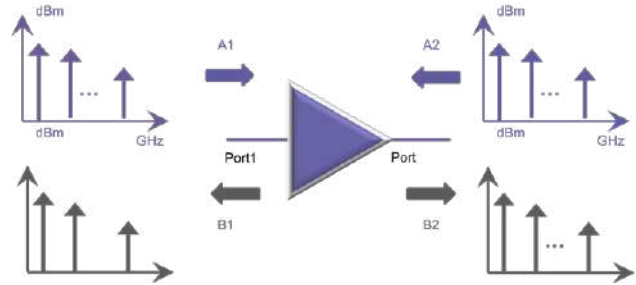

Incident and scattered waves contain fundamental and harmonic tones

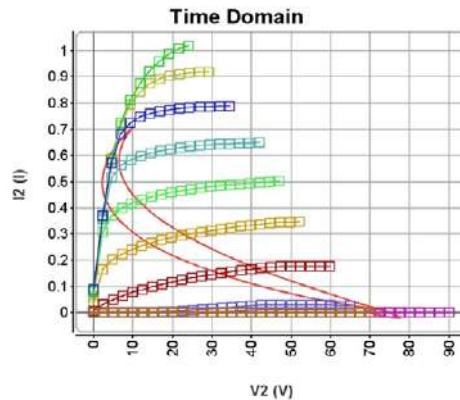

Used in combination with IVCAD Software, this Comb Generator enables an accurate phase calibrated measurement of harmonic signals when measured with a Vector Network Analyzer, in order to provide a true RF waveform measurements at the DUT reference plane.

This phase calibration standard allows optimizing the operating class of RF transistors using harmonic load tuning with IVCAD MT930C VNA based load pull measurement bench control and IVCAD MT930GA Time-Domain LSA software module.

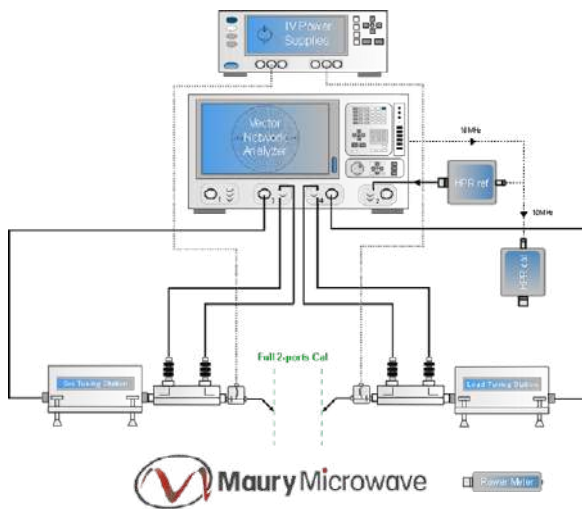

Large Signal Analysis load pull measurement bench architecture

Application example 2

RF Transistor EPHD Behavioral Modeling

RF measurements of magnitude and phase-calibrated harmonic signal can be used to extract transistor's Enhanced Poly-Harmonic Distortion (EPHD) Model using IVCAD MT930R1 IVCAD software module.

Using the comb generator, a transistor model can now be extracted within 2 or 3 days at several frequencies. Including, calibration, measurements, extraction and model validation time.

[See IVCAD MT930R1 Behavioral Modeling Extraction and Simulation operating manual](#)

With IVCAD **MT930C** VNA Based Load Pull and IVCAD **MT930GA** Large Signal analysis modules, harmonic phase-calibration and harmonic impedance control are used to generate time-domain load pull data which can be used to extract a transistor model directly from large signal measurements.

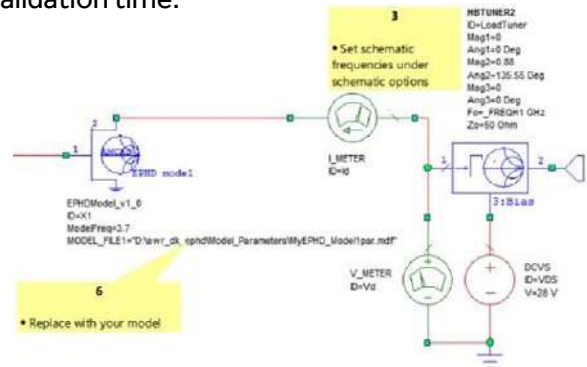

Incident and scattered waves contain fundamental and harmonic tones

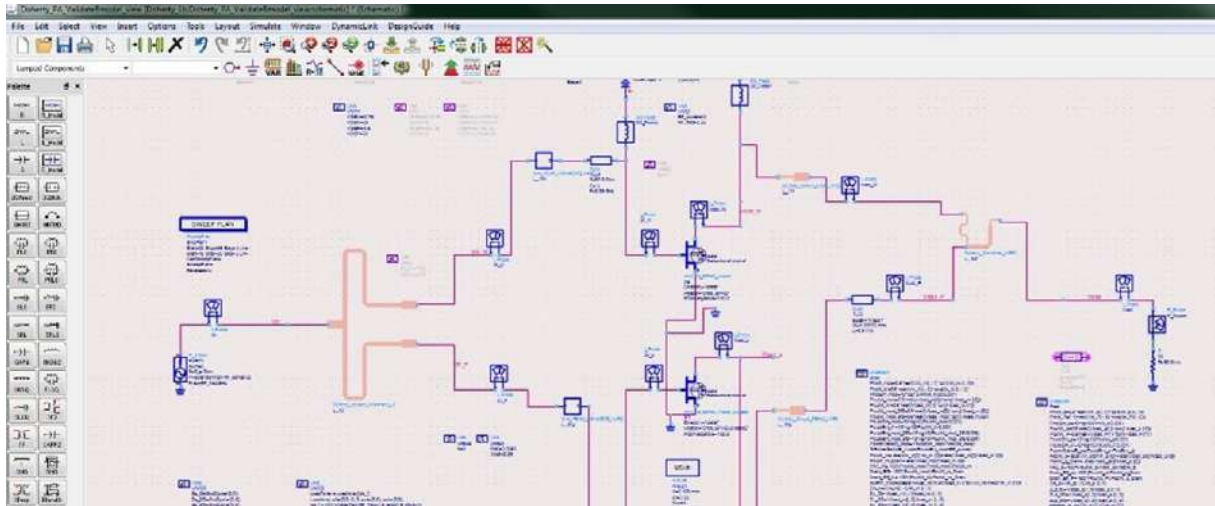

Doherty simulation using an EPHD transistor behavioral model with Keysight Pathwave ADS circuit simulator

Application example 3

EMC testing

The **HPR7227A** comb generator can be used as a very broadband reliable EMC signal source reference for rapid and efficient testing. The HPR can generate signals up to 26GHz at frequency intervals as small as 10MHz. EMC Laboratories calibrate their test sites, instrumentation and accessories regularly.

Calibration procedures can be complex and time consuming. However, in EMI/EMC test site validation, using calibrated instruments does not prevent bad readings. These may be due to multiple causes, such as damaged receivers, broken cables, bad connections, or a defective antenna.

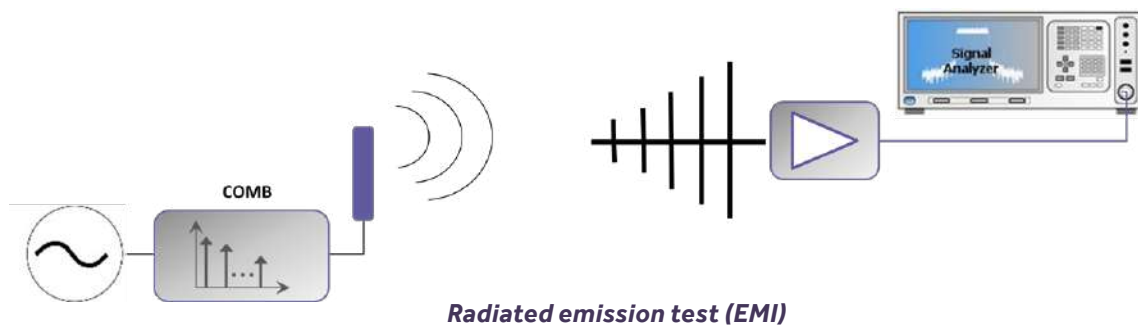

Monitoring the radiated signal with an antenna using a very wideband signal makes it possible to check the entire configuration of the test

site very quickly and efficiently. Any potential problem with the test setup can be detected before it causes erroneous results.

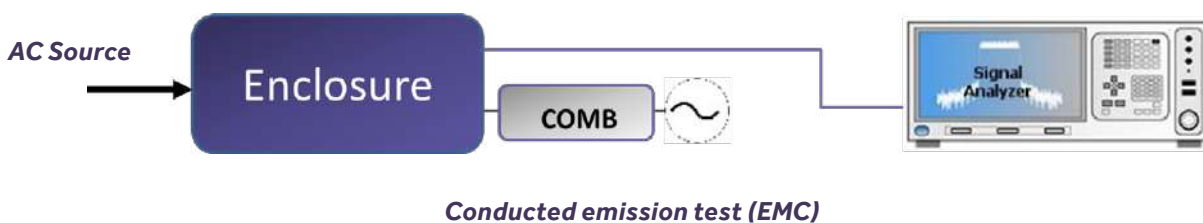

Equipped with an external RF source, and a broadband antenna, the compact size of our comb generator allows small enclosures to be evaluated when used as a reference source for shielding effectiveness measurements. The comb generator is supplied with a super

SMA input connector and two 2,92mm output connectors (Male and Female) for direct connection to wired test systems, or to an external antenna in order to generate test fields for evaluating radiated emission test systems.

Specifications Table

	Minimum	Typical	Maximum	Unit
Bias				
Voltage	4.3			V
Current				mA
Input signal				
Frequency	10 MHz		7 GHz	
Peak-to-peak Level	0.2		3.4	V _{pp}
Absolute Level	-3.8		+3.8	V
Output signal @10MHz Input				
Pout [10 MHz –4 GHz]	-65			dBm
Pout [4 –7 GHz]	-68			dBm
Pout [7 –8,5 GHz]	-71			dBm
Pout [8,5 –11,5 GHz]	-74			dBm
Pout [11,5 –17 GHz]	-79			dBm
Pout [17 –20 GHz]	-83			dBm
Pout [20 –23 GHz]	-87			dBm
Pout [23 –24 GHz]	-90			dBm
Pout [24 –26,5 GHz]	-99			dBm
Pulse width		45		ps
Phase Stability				
10 MHz – 7 GHz			±/2	°
7 – 23 GHz			±/5	°
23 – 26.5 GHz			±/10	°
Operating T°	-40	25	+65	°C

Mechanical Dimensions

- **Weight** : 120 g
- **Input connector** : Super SMA female
- **Output A connector** : 2,92mm male
- **Output B connector** : 2,92mm female
- **Dimension** : mm

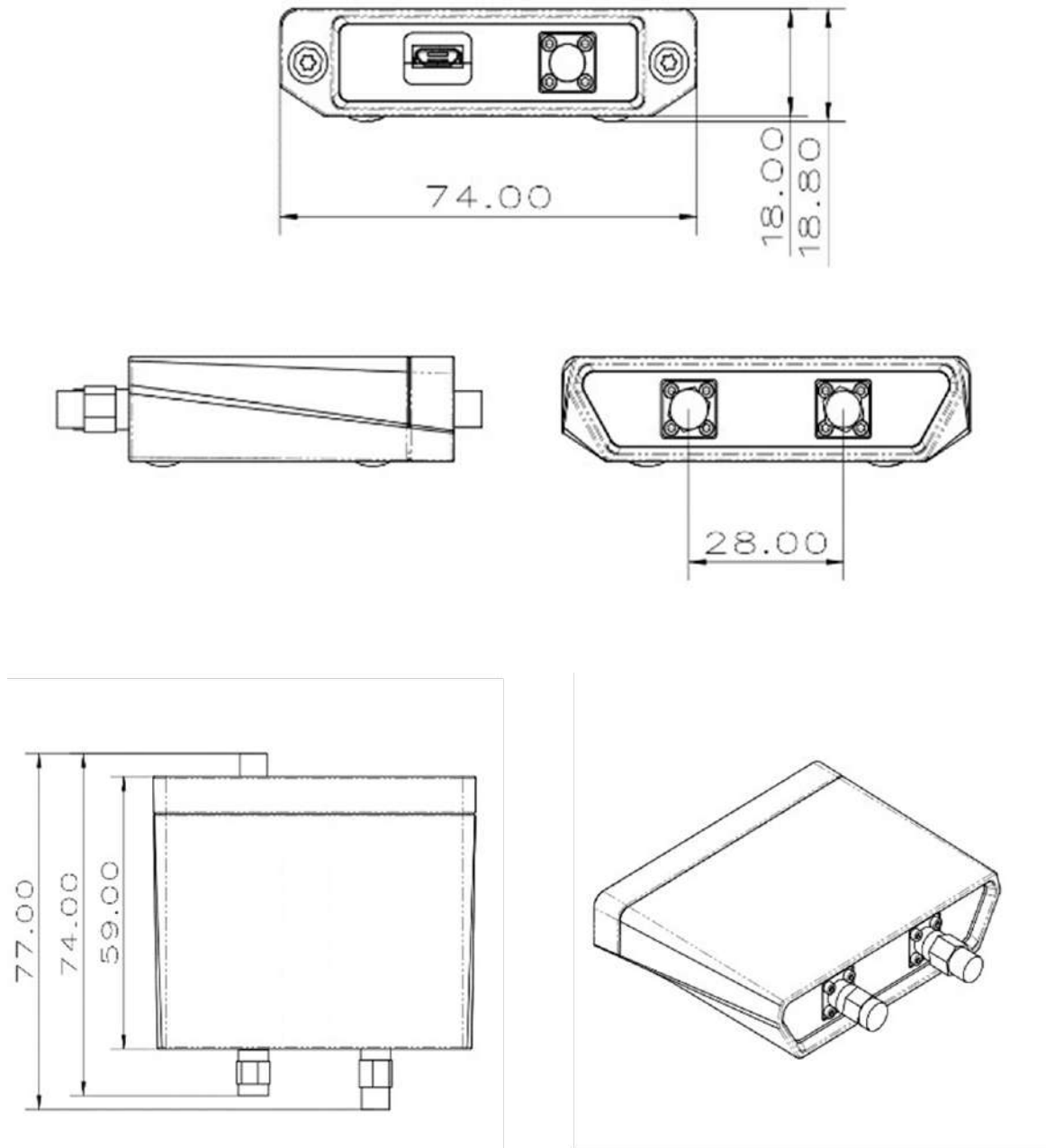

Measurement Example

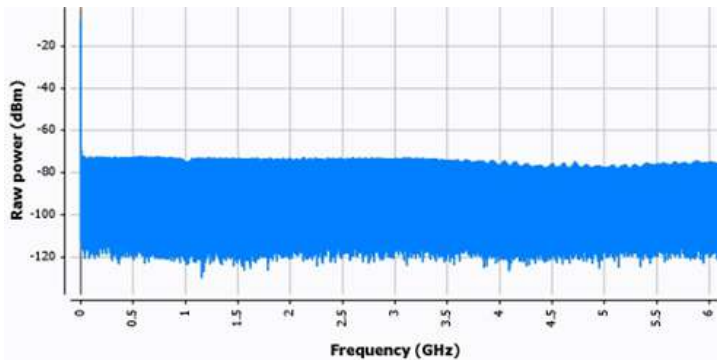

Input 10MHz // Output from 10MHz to 6GHz

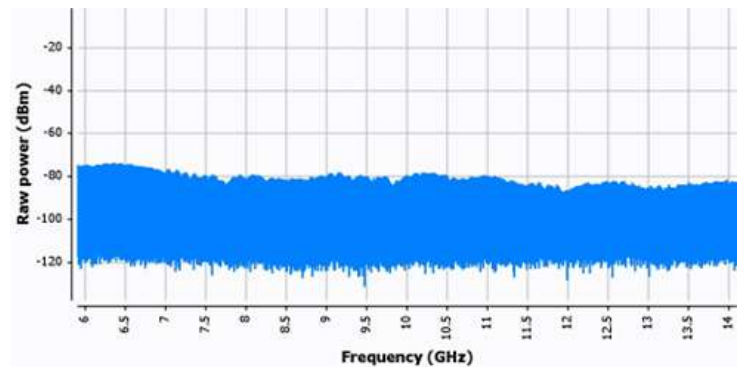

Input 10MHz // Output from 6GHz to 14GHz

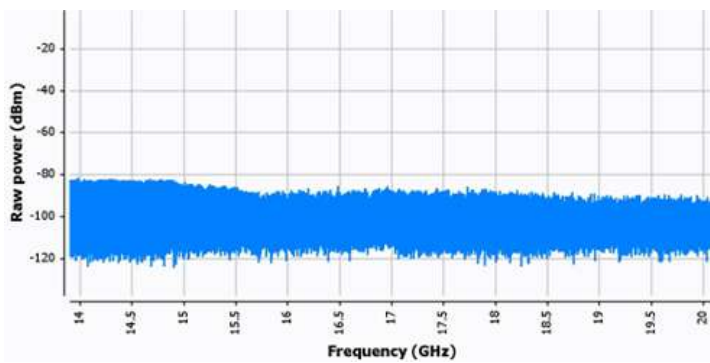

Input 10MHz // Output from 14GHz to 20GHz

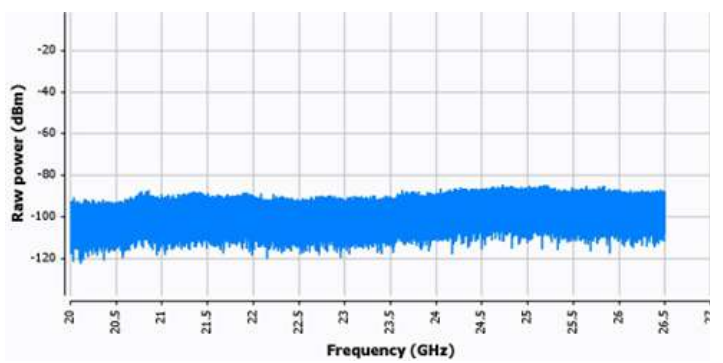

Input 10MHz // Output from 20GHz to 26.5GHz

Note: Typical and nominal characteristics are included for information only and they are not specifications.

Measurement Example

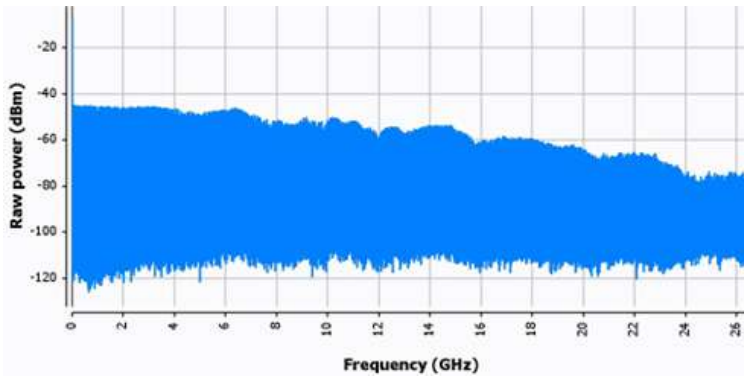

Input 50MHz // Output from 50MHz to 26.5GHz

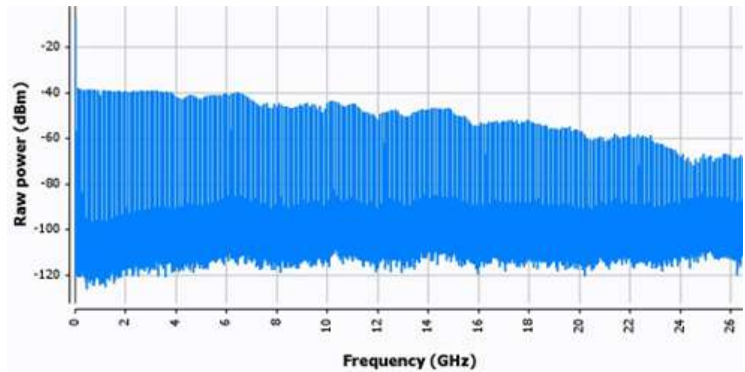

Input 100MHz // Output from 100MHz to 26.5GHz

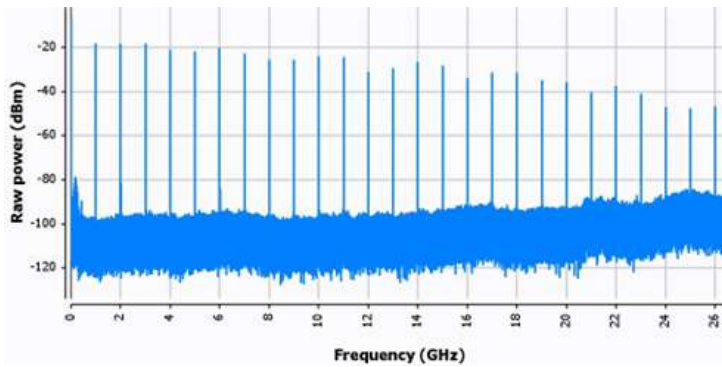

Input 1GHz // Output from 1GHz to 26.5GHz

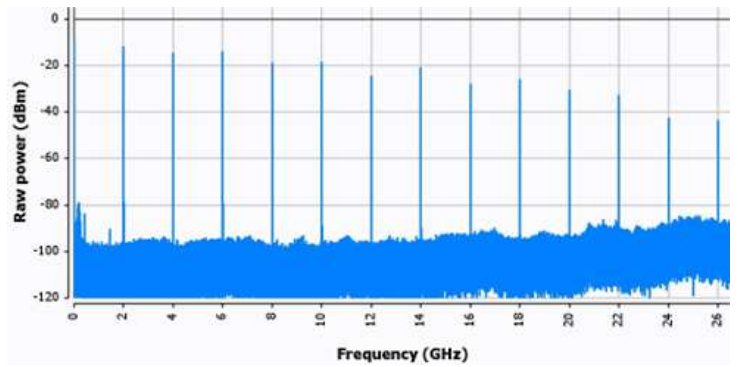

Input 2GHz // Output from 2GHz to 26.5GHz

Note: Typical and nominal characteristics are included for information only and they are not specifications.

Measurement Example

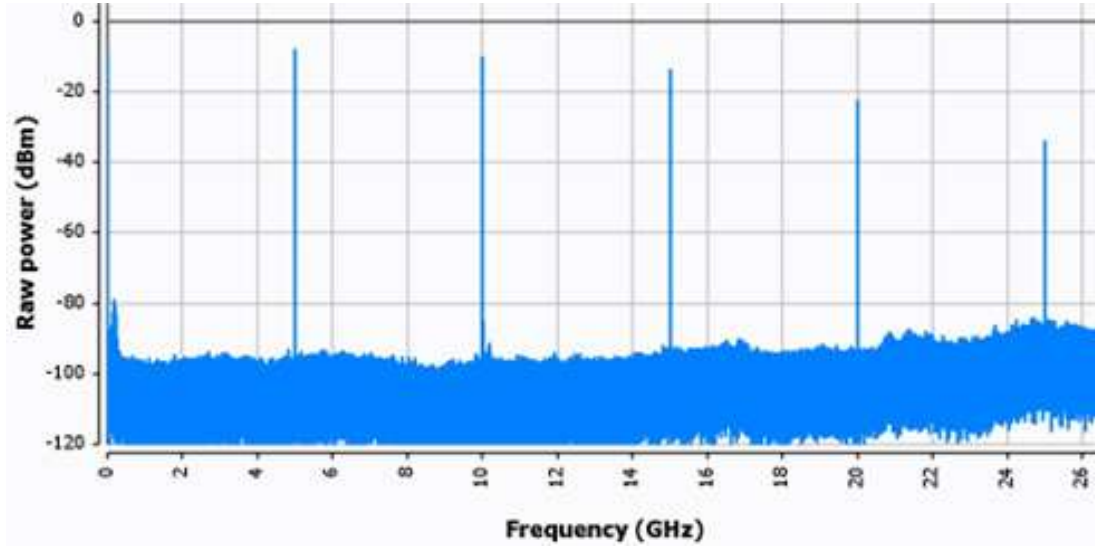

Input 5GHz // Output from 5GHz to 26.5GHz

Note : Typical and nominal characteristics are included for information only and they are not specifications.



Measurement Example

HPR7227A Power

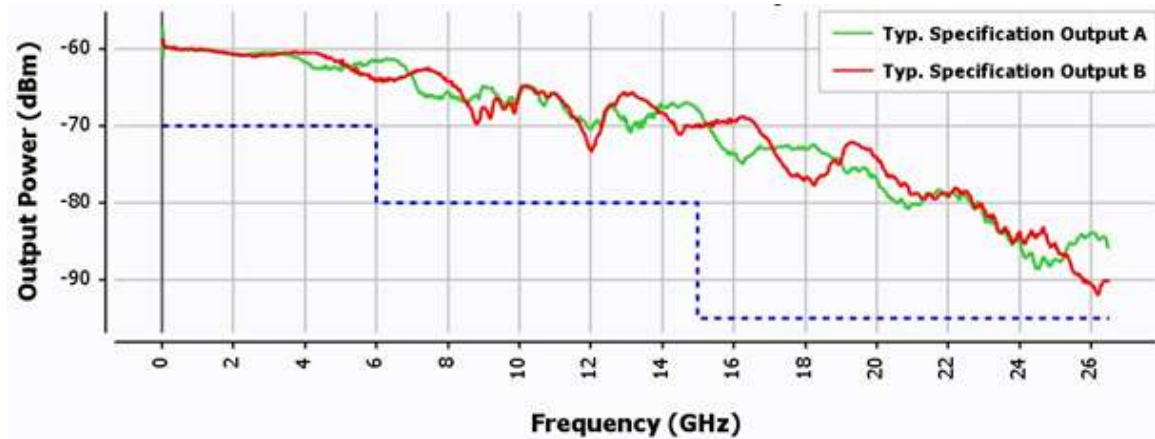

HPR7227A Normalized Phase* at 10MHz PRF

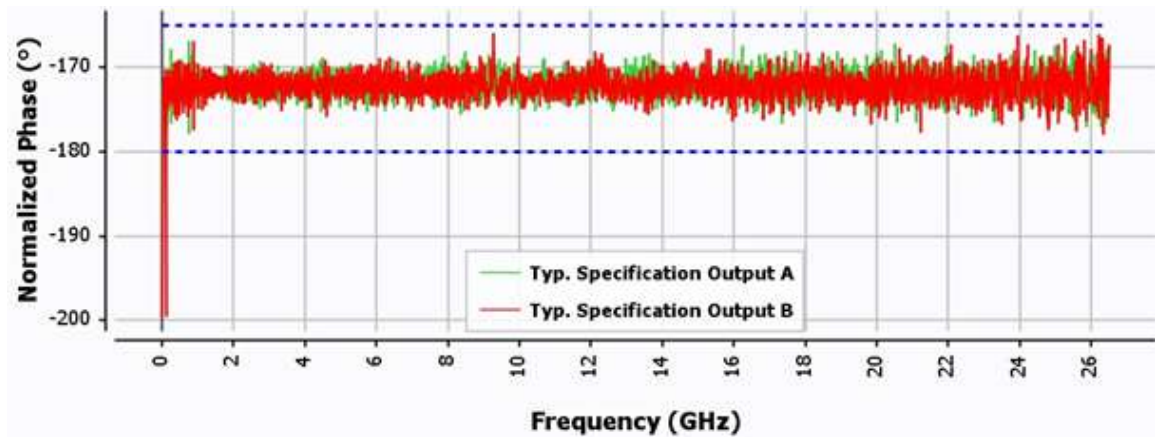

***Normalized Phase** : Phase difference between 2 successive harmonic tones

Note : Typical and nominal characteristics are included for information only and they are not specifications.

CONTACT US

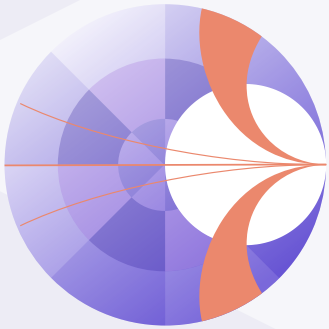

AMCAD SAS

Bâtiment Galiléo | 20 rue Atlantis, 87068 Limoges FRANCE

Email: sales@amcad-mw.com

Phone: +33 5 47 74 42 30

*This document may not be reproduced, modified, adapted, published, translated, in any way, in whole or in part, or disclosed to a third party without the prior written consent of AMCAD SAS
© Amcad 2024*