

PRODUCT: QR-URN3760

WEIGHT: 3,114 lbs.
(CUSTOMER TO OFFLOAD IF OVER 6000 Lbs.)

Authorized Signature

Date

By signing above or stamping this drawing "approved" or "no exception taken" authorization is given to QCP to produce this drawing as shown within a 1/4" tolerance.

QUANTITY: ___

- CONCRETE COLOR:
- QUAIL HILL RED
 - NATURAL
 - MISSION WHITE
 - LATTE
 - HARVEST
 - FRENCH GREY
 - BUNGALOW
 - ADOBE TAUPE
 - CUSTOM COLOR

- CONCRETE TEXTURE:
- CRAFTSMANS ETCH
 - STRATA

SEALER: STANDARD SEALER

GENERAL PRODUCT NOTES:

E = EXPOSED FINISHED SURFACE
 INSTALLATION IS REQUIRED BY OTHERS.
 ALL EDGES TO BE EASED.
 MANUFACTURING TOLERANCE ±1/4".
 STD. 2" DIA. DRAIN HOLE
 INCLUDES INTERIOR WATER SEALANT

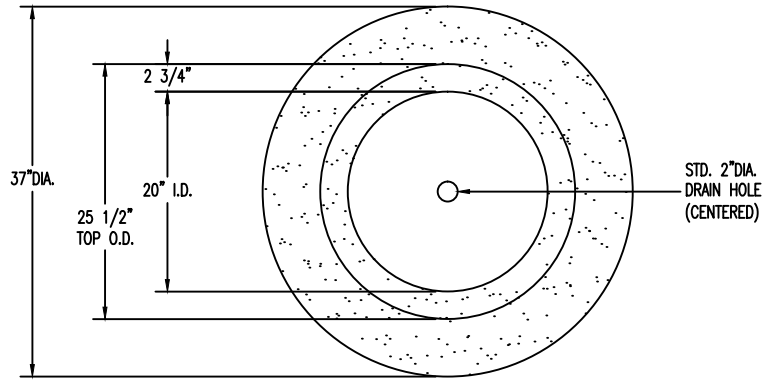

PLAN VIEW

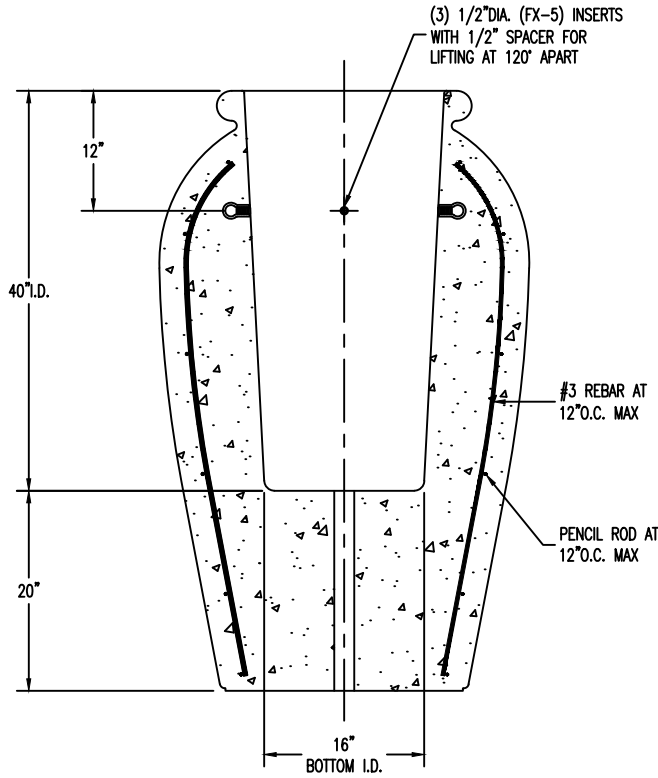

SECTION VIEW

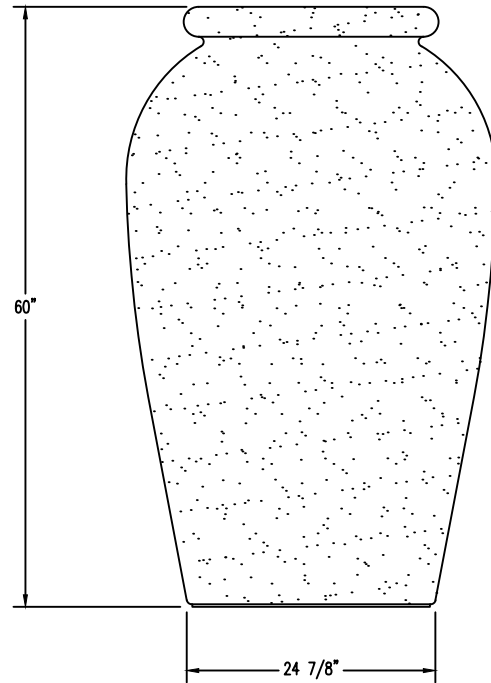

ELEVATION VIEW



PLAN TYPE	CONSTRUCTION PLAN	DATE	3/18/17	FILE NO.	QR-URN3760	SHEET	1
PRODUCT	QR-URN3760 ROUND PLANTER URN	SCALE	5/8" = 1'	DRAWN BY:	----	OF	
PROJECT NAME		PC. NO.		QC ITEM NO.			1