

PRODUCT: Q2-ORION-S

WEIGHT: 244 lbs.
(CUSTOMER TO OFFLOAD IF OVER 6000 Lbs.)

Authorized Signature _____

Date _____

CONCRETE COLOR:

- NATURAL
- MISSION WHITE
- CUSTOM: _____
- FRENCH GREY
- LATTE

CONCRETE TEXTURE:

- CRAFTSMANS ETCH
- STRATA
- HONED

QUANTITY: _____

SEALER: PERMASHIELD 4200 SEALER

By signing above or stamping this drawing "approved" or "no exception taken" authorization is given to QCP to produce this drawing as shown within a 1/4" tolerance.

GENERAL PRODUCT NOTES:

E = EXPOSED FINISHED SURFACE
 INSTALLATION IS REQUIRED BY OTHERS.
 ALL EDGES TO BE EASED.
 MANUFACTURING TOLERANCE ±1/4".
 ANCHORING METHOD BY OTHERS

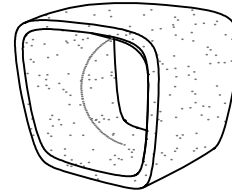

ISOMETRIC VIEW

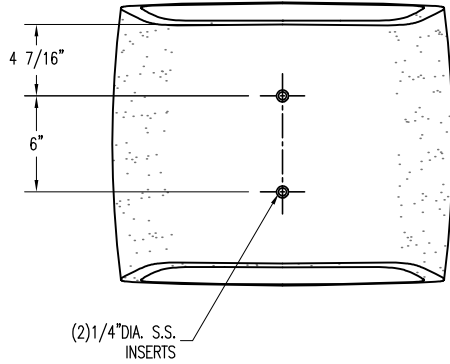

BOTTOM VIEW

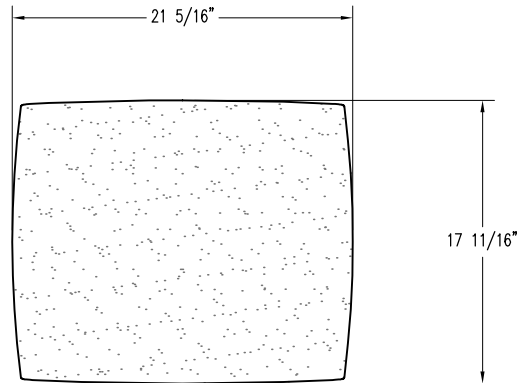

PLAN VIEW

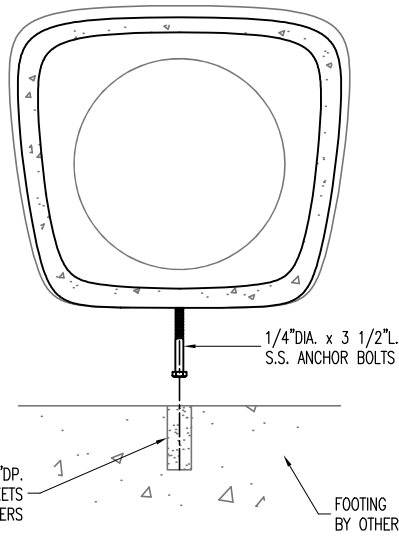

SECTION VIEW
INSTALLATION DETAIL

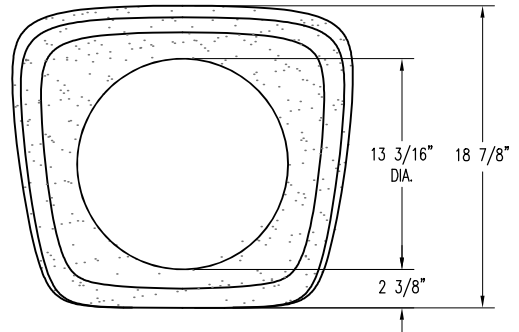

ELEVATION VIEW

HARDWARE LIST	
QTY	TYPE
2	1/4" DIA. X 3 1/2" L. S.S. ANCHOR BOLTS



PLAN TYPE	CONSTRUCTION PLAN	DATE	3/10/26	FILE NO.	Q2-ORION-S	SHEET	
PRODUCT	Q2-ORION-S SEATING ORION	SCALE	0'-1" = 1'	DRAWN BY:	----	OF	
PROJECT NAME		PC. NO.		QC ITEM NO.			