

MAGNETRON SWITCHED MODE POWER SUPPLY

BPA Series, 1 kW / 2450 MHz

:fm

GENERAL INFORMATION

The BPA1kW is an air-cooled, switched-mode power supply (SMPS) engineered for 2450 MHz magnetron applications. The system delivers tightly regulated high-voltage DC output with low ripple characteristics, ensuring stable magnetron operation and extended device lifetime.

Advanced digital control algorithms continuously regulate anode voltage, anode current, and filament supply to precisely maintain the magnetron operating point, with fast and reliable response to all abnormal conditions.

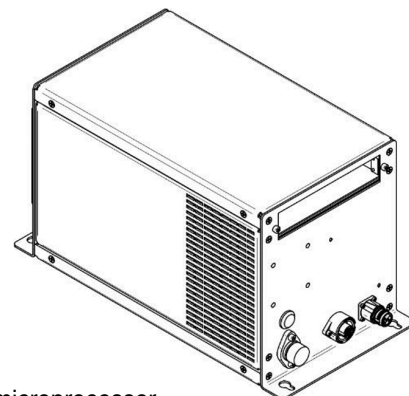

FEATURES

- Air-cooling high efficiency system up to 97 %, no external water circuit required for the SMPS
- Accurate anode voltage and anode current measurement and closed-loop control using DSP microprocessor
- Cutting-edge resonant switching topology with low output ripple, less than 1 % voltage, less than 2 % current
- Comprehensive protection suite: over/under temperature, over/under voltage, overcurrent, overload, and short-circuit
- High reliability design compliant with MIL-HDBK-338B and MIL-HDBK-217 standards
- Flexible output power range: adjustable from 20 % to 100 % of the rated power
- Compatible with multiple magnetron brands and models
- Industrial communication options: PROFINET, EtherCAT, analog 0 V to 10 V, or Modbus TCP
- All high-quality power electronics and mechanical components sourced from Germany

SPECIFICATION ELECTRICAL AND TECHNICAL DATA

	BPA1kW200	BPA1kW380	BPA1kW400	BPA1kW480	BPA1kW600	BPA1kW690
Input voltage	200 V _{AC} ± 10 %	380 V _{AC} ± 10 %	400 V _{AC} ± 10 %	480 V _{AC} ± 10 %	600 V _{AC} ± 10 %	690 V _{AC} ± 10 %
Efficiency	up to 94 %	up to 95 %	up to 96 %	up to 96 %	up to 97 %	up to 97 %
Input frequency	47 Hz to 63 Hz					
Power consumption	1.65 kVA					
Output voltage adaptivity	3.8 kV to 4.6 kV					
Anode current variation range	70 mA to 350 mA					
Absolute Max. output power	1.1 kW					
Output voltage ripple	Less than 1 %					
Anode current ripple	Less than 2 %					
Active operating temperature	-20 °C to 50 °C					
Working humidity	20 % to 90 % RH, non-condensing					
Storage temperature, humidity	-30 °C to +70 °C, 10 % to 95 % RH non-condensing					
Withstand voltage	10 kV					

DIMENSIONS OF SMPS

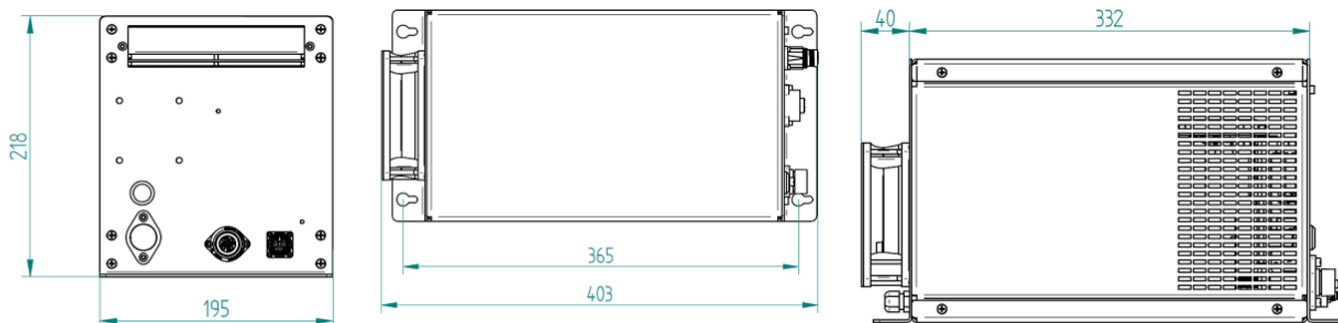

Note: All dimensions are in mm.