

3D Reinforced Blanks: Additive Solutions for Localized BIW Stiffness

Cristian Alvarez Robledo

R&D Breakthrough Program Leader

ArcelorMittal Global R&D

Nachiket Gokhale

Product Development Manager

ArcelorMittal Tailored Blanks

GREAT DESIGNS IN
STEEL™

Agenda

1. Industry Challenges and Opportunities
2. 3D Reinforced Blanks – Introduction and Process Overview
3. Case study – Rear Underbody Stiffness
 - a) Industry Benchmark
 - b) Optimization
4. Conclusions

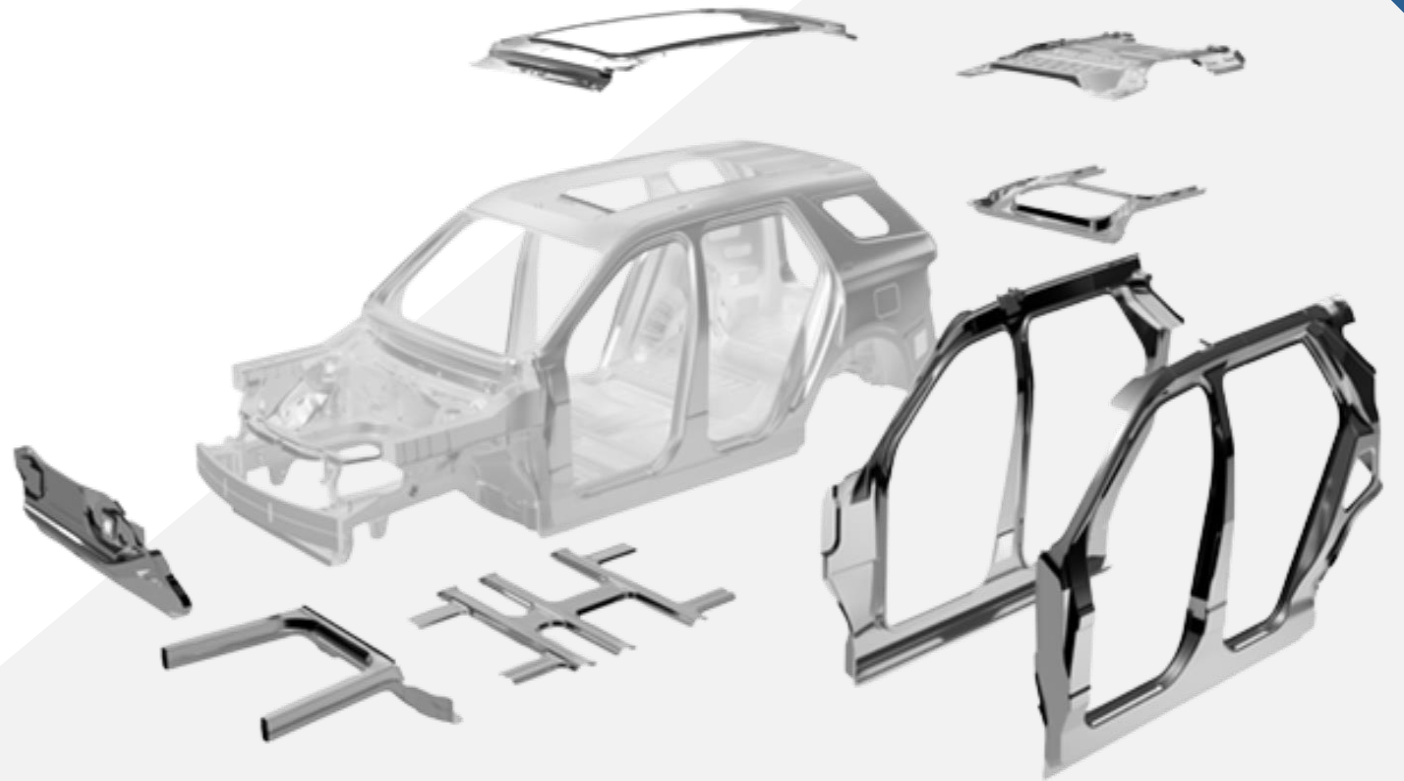

Industry Challenges & Opportunities

What Do Customers Want?

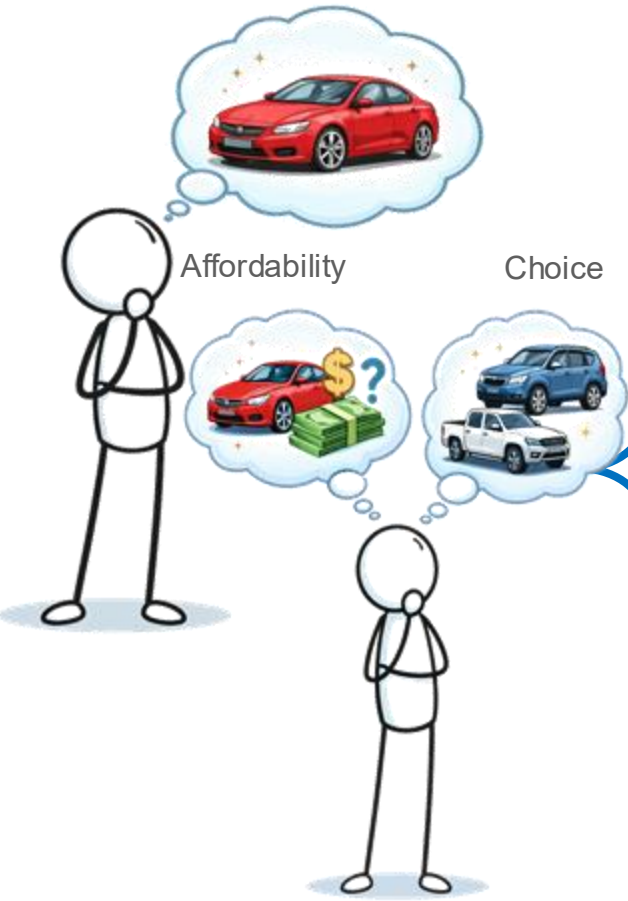

OEM Strategy

Mix Model Assemblies
Multiple Powertrains

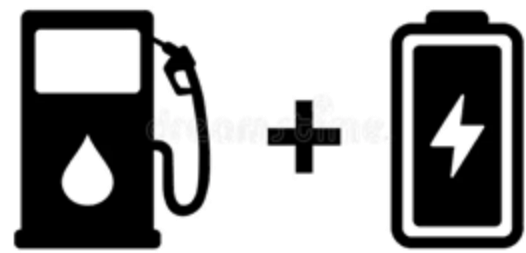

Assembly Simplification
Part Count Reduction
Crash Safety

ArcelorMittal Multi Part Integration®

Laser Welded Blanks



Giga Castings

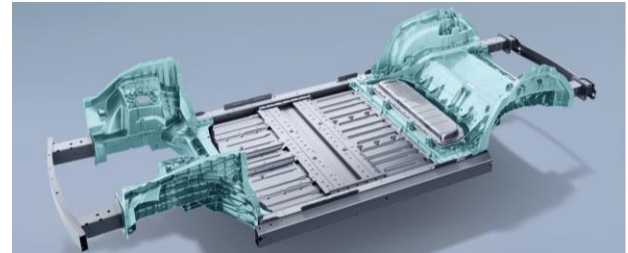

Source - Xpeng G6

Vehicle buyers want multiple affordable car options driving OEM strategy for cost reduction

Industry Challenges & Opportunities



Big Consolidated Steel Stampings



Industry Standard

Current LWB Capability

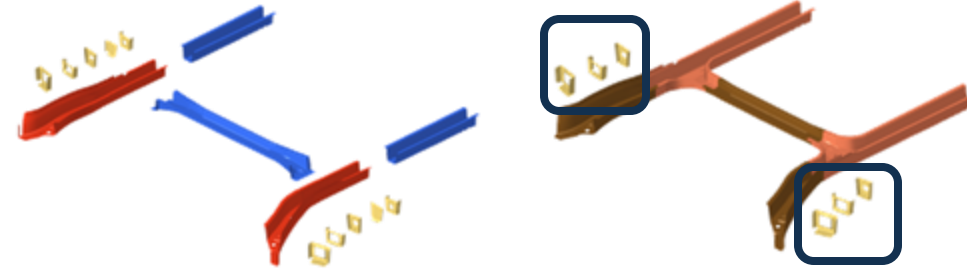

Small Brackets and Reinforcements

How to integrate additional reinforcements?

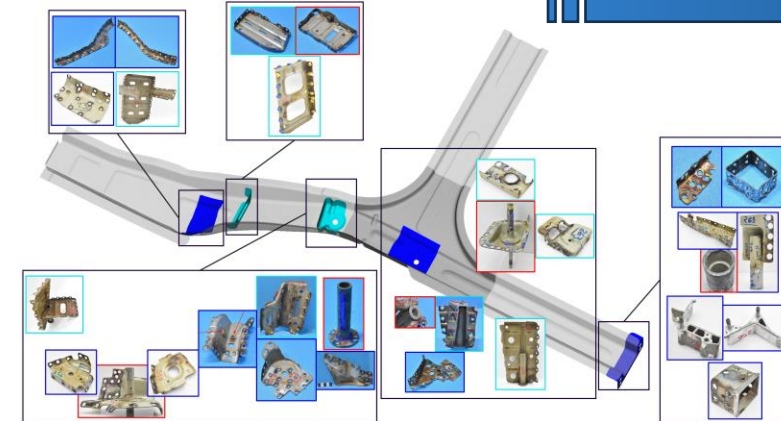

LWB For Best Material Utilization

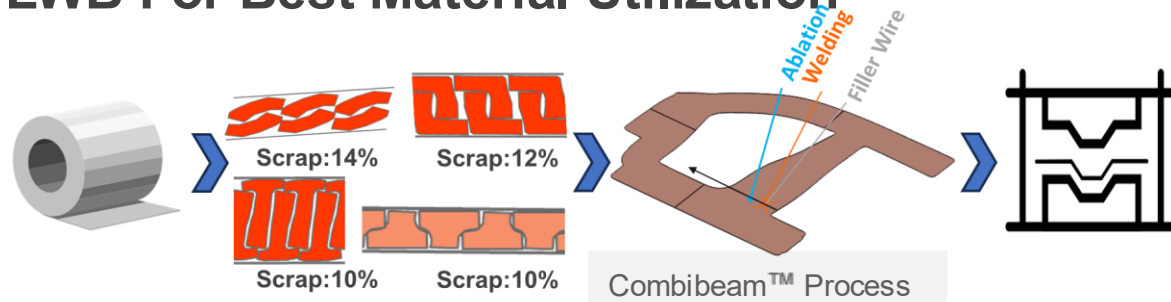

*Source - A2Mac1

ArcelorMittal Multi Part Integration® (MPI) concepts enable powertrain agnostic crash safety

3D Reinforced Blanks – Development Goals

- Modularity and design flexibility
- Simple integration in current manufacturing flows
- Same or better performance (crash and stiffness), lower weight
- Same corrosion performance

Drive towards Increased Part Integration !!

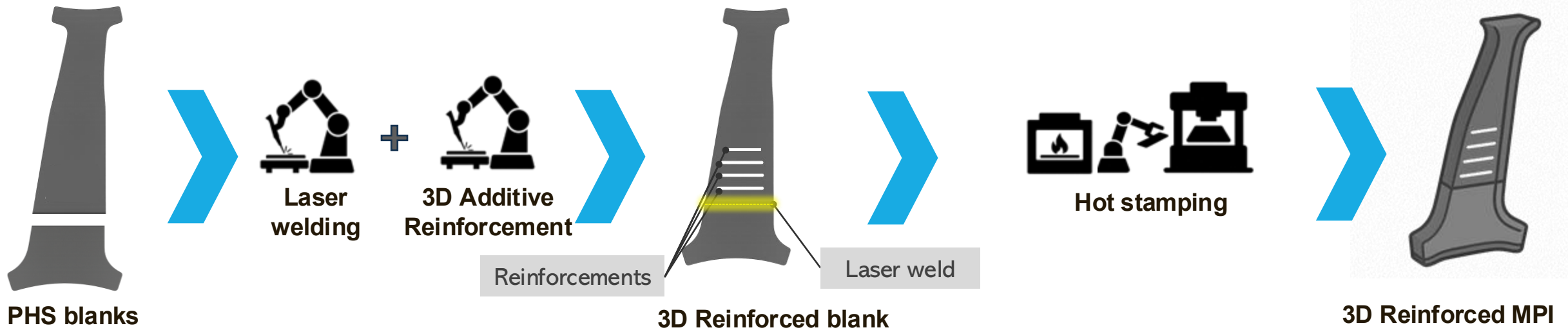

Wire Additive Manufacturing technology choice:

- ✓ Design flexibility
- ✓ Good compromise between productivity and cost
- ✓ Equivalent performance at lower weight

Hot stamping technology choice:

- ✓ Reduced residual stress and low springback on final part
- ✓ No heat affected zones on final part
- ✓ Widely used in automotive industry

3D Reinforcement of MPI blanks enables increased part integration within existing supply chain

3D Reinforced Blanks – Process Details

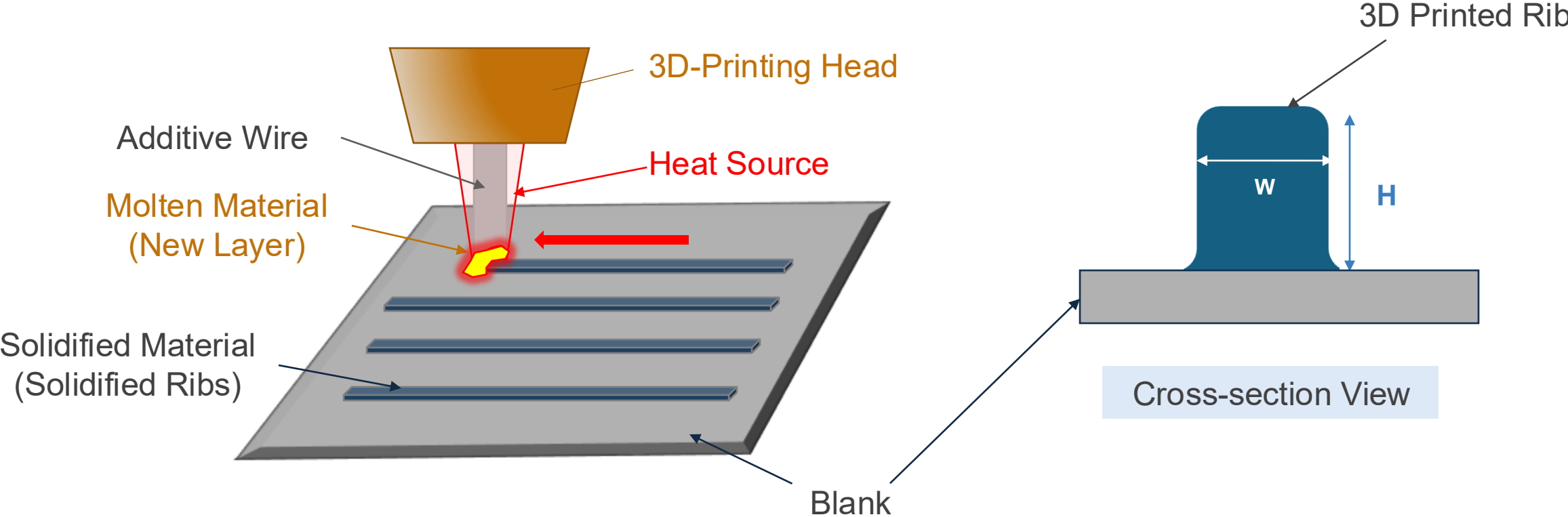

Printing process consists of a heat source that melts a wire to build 3D metal layer on the blank

3D Reinforced Blanks – Wire Selection

Mechanical Properties

- Martensitic microstructure after hot-stamping
- Maximum stiffness and reaction force
- No brittle failure of the assembly

Corrosion Performance

- Low high-temperature oxidation during hot stamping
- Good paint adhesion
- Corrosion similar or better than a regular PHS LWB

Martensitic Microstructure

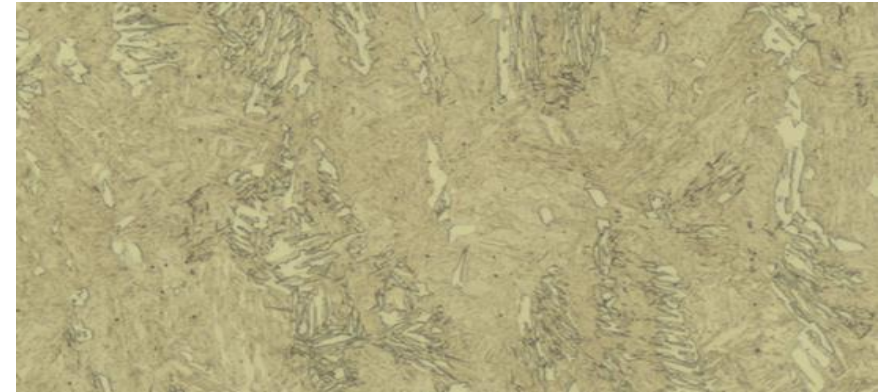

Corrosion performance – 12 Weeks VDA233-102

Usibor®1500 AS150



Uncoated 22MnB5



Wire developed for high quenchability, mechanical properties and corrosion performance

3D Reinforced MPI Blanks – CAE and Validation

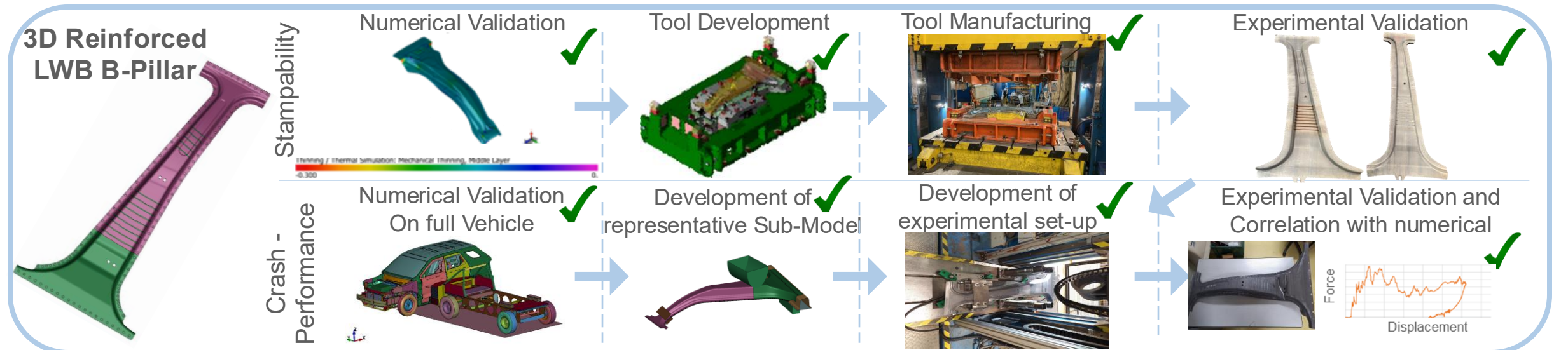
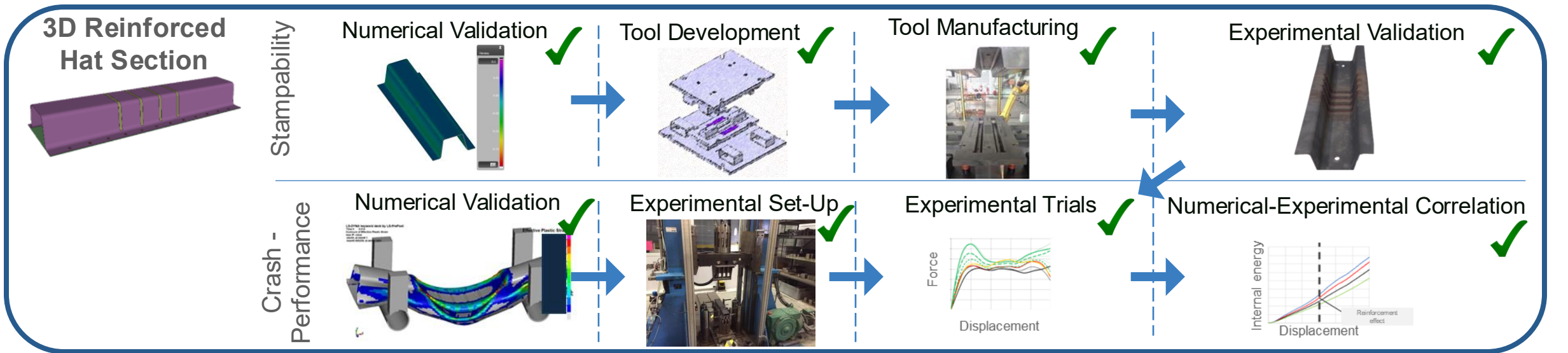

Full numerical and experimental chain to support new part development

Case Study: Rear H-Frame MPI with 3D Reinforced Blanks

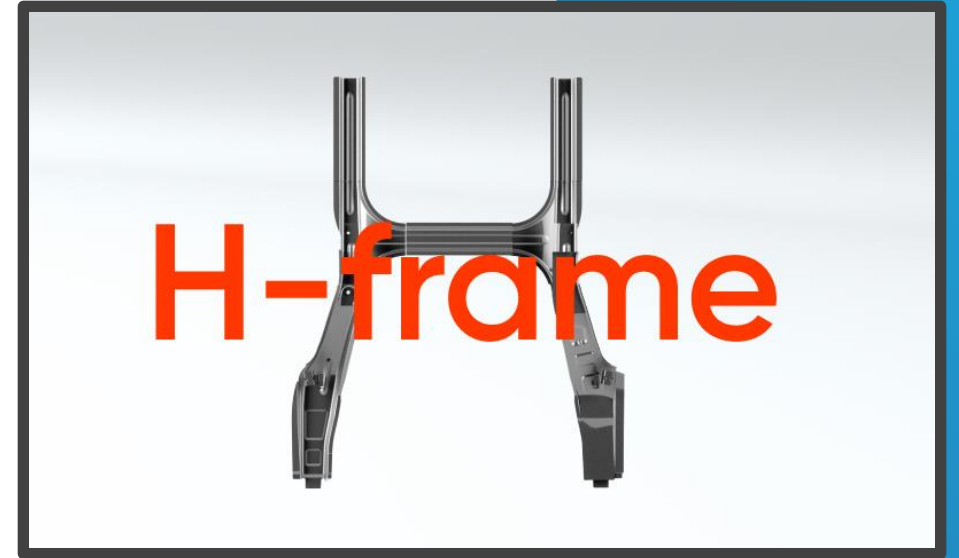

GREAT DESIGNS IN
STEEL™

Rear Assembly – EV SUV Benchmark Examples



North America OEM1 CUV-BEV

North America OEM2 SUV-BEV

Baseline Multipart S-In Motion®

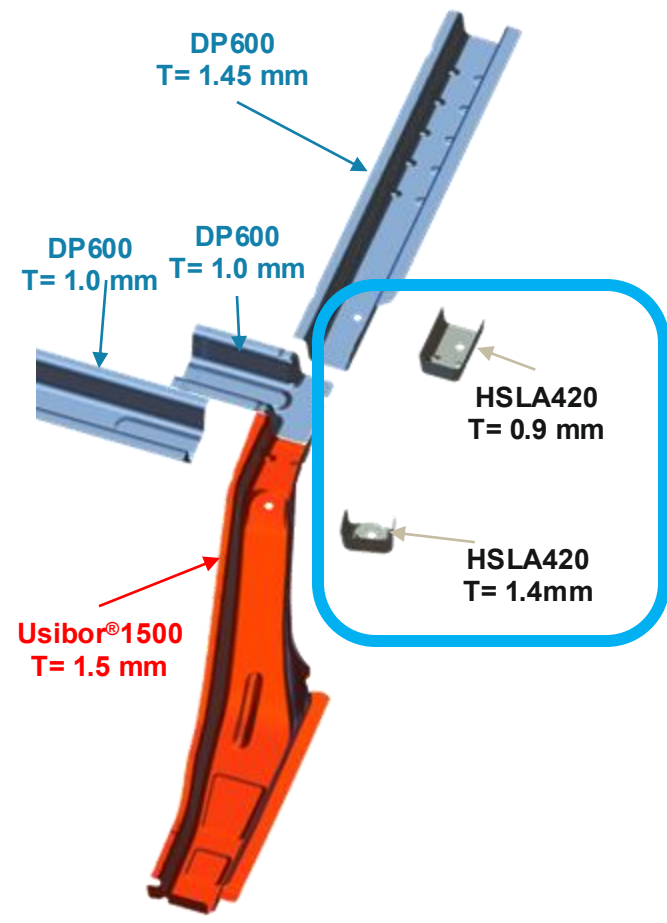
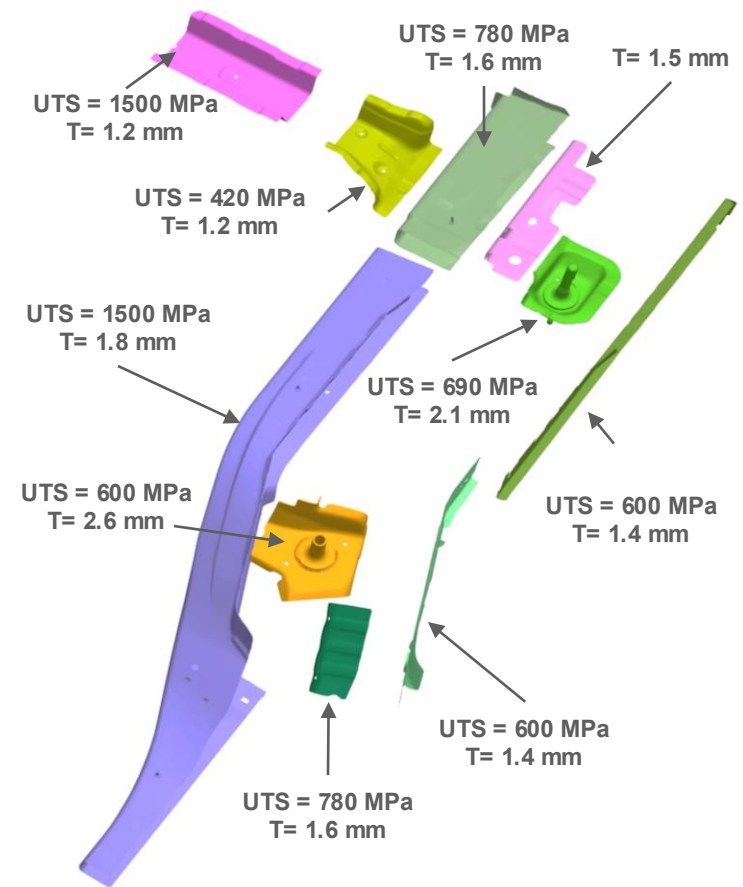
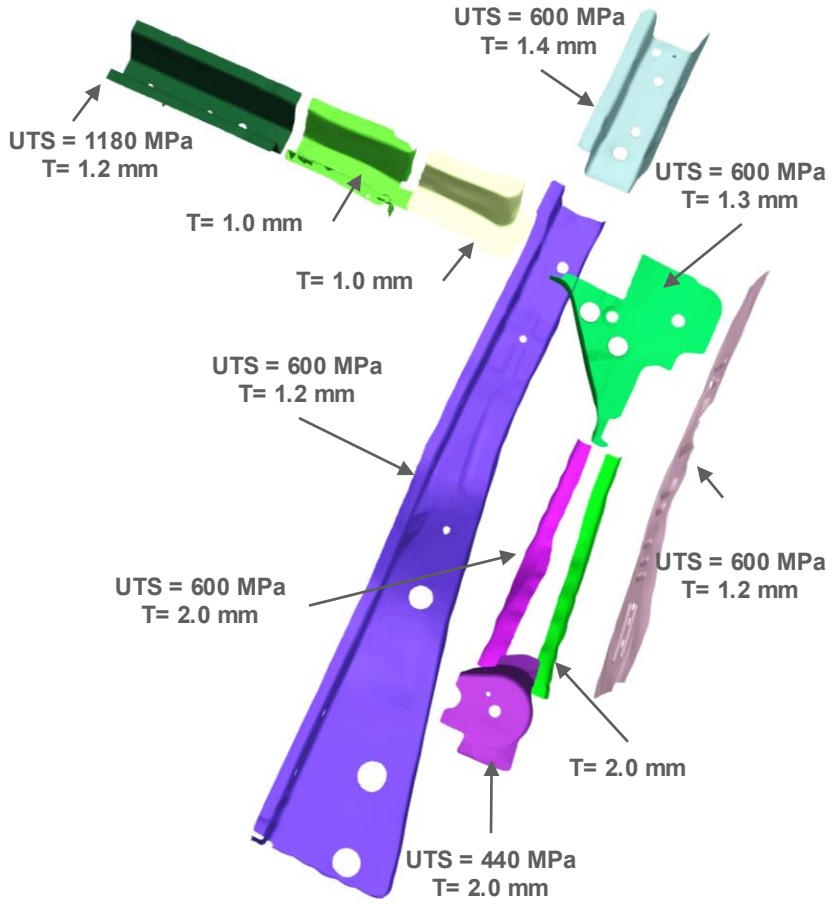

*Source - A2Mac1 (RH shown. LH/RH symmetric)

Current industry standard is multi part construction with overlapping sections

3D Reinforced Rear H-Frame MPI



Baseline
Multipart

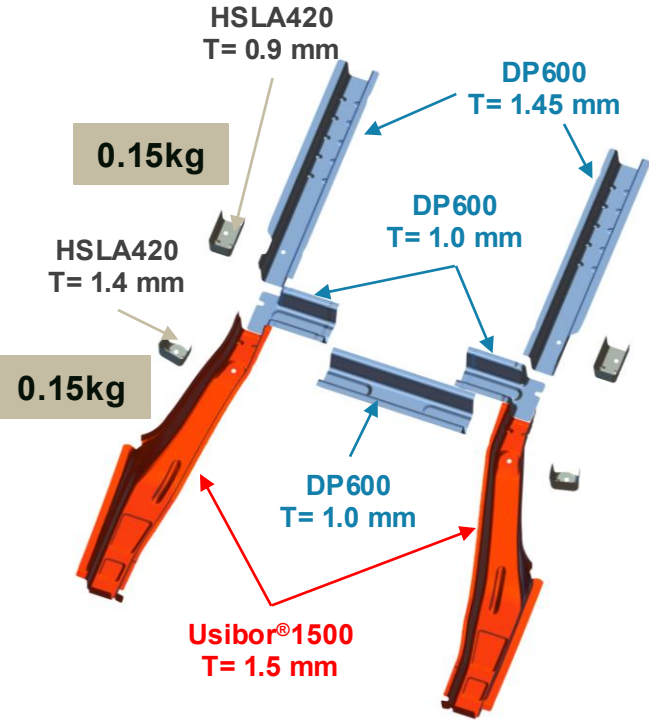

Rear H-Frame MPI Solution +
Patch Reinforcements

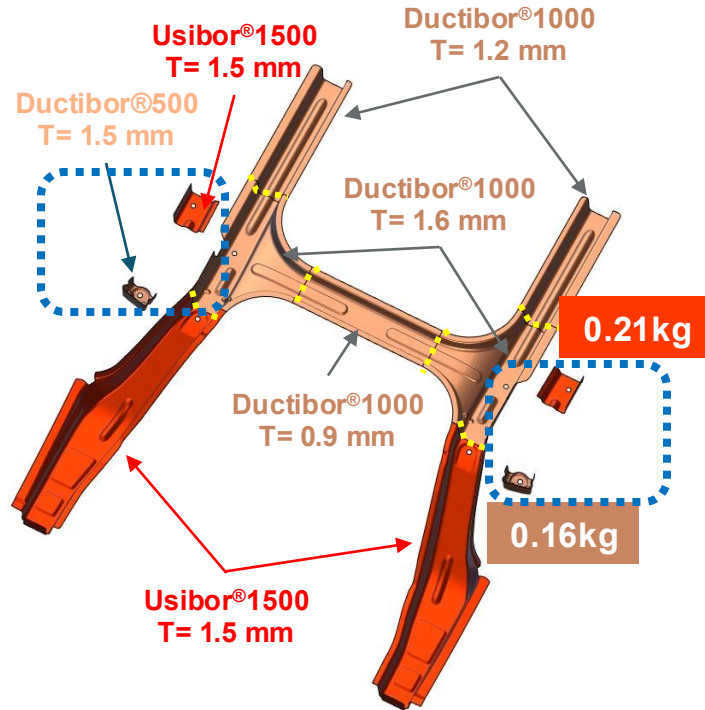

3D Reinforced H-Frame
MPI Solution

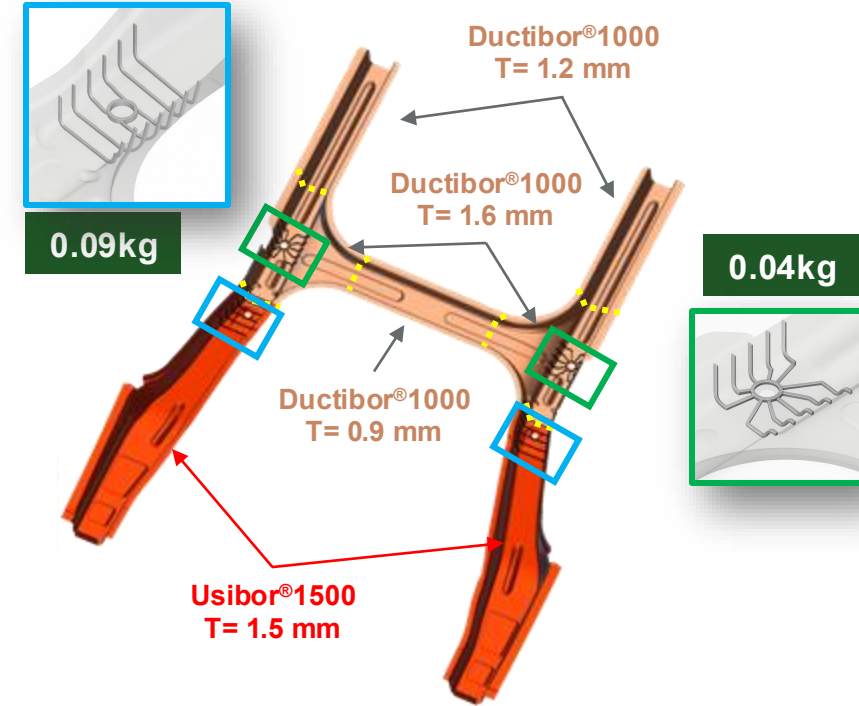

11 Parts per vehicle
Part Weight 12.92 kg/vehicle

5 Parts per vehicle
Part Weight 12.44 kg/vehicle (-3.7%)

1 Part per vehicle
Part Weight 11.98 kg/vehicle (-7.3%)

*Source – GDIS 2022 ([link](#))

3D Reinforcement of MPI blanks enable part integration of separate reinforcements

3D Reinforced Rear H-Frame MPI: Load cases

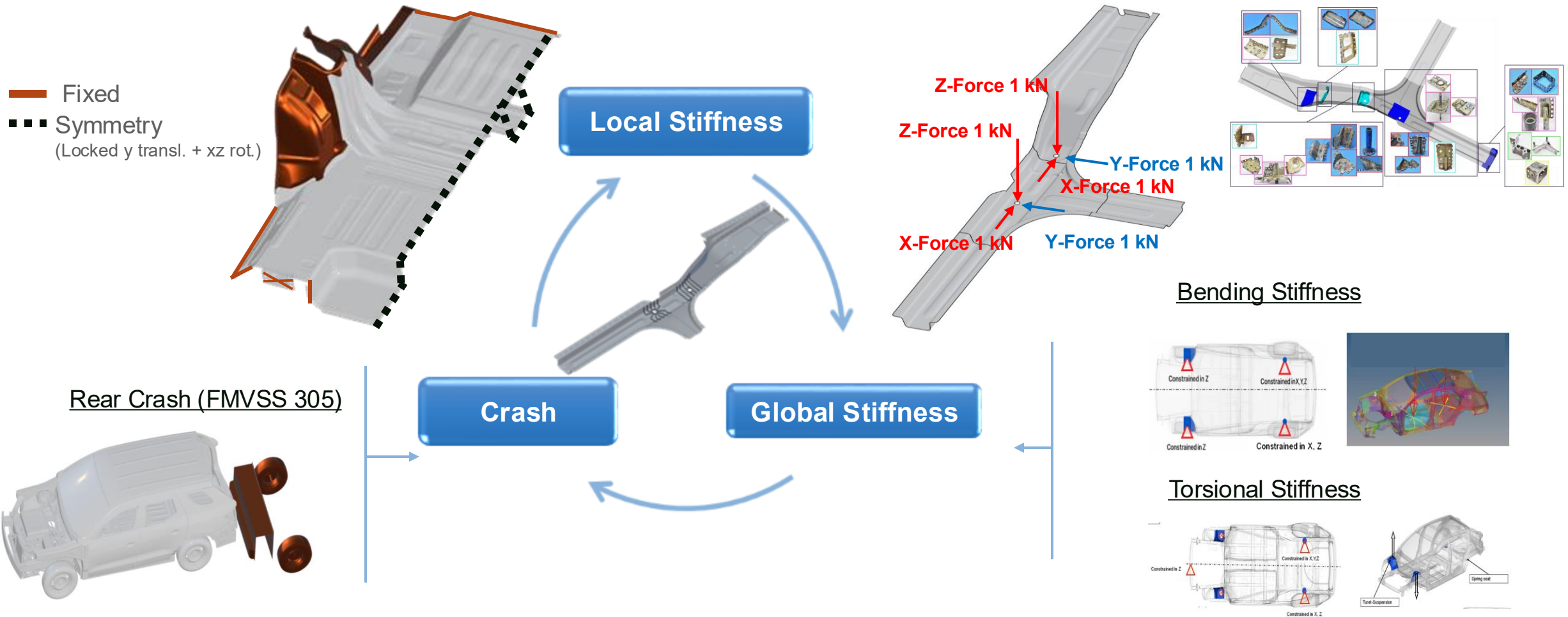

Designs evaluated using local and global stiffness with rear crash for additional performance validation

Local Stiffness Topology Optimization

Front 3D reinforcement

Optimization Results

4.2kN/mm

0.16 kg

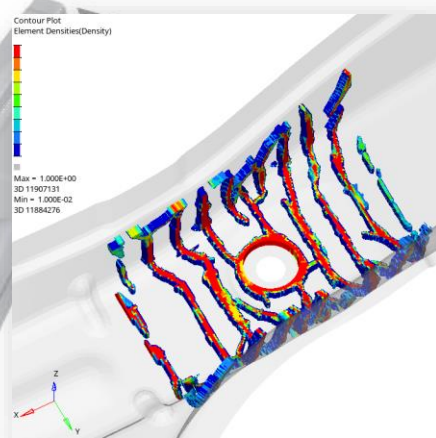

Interpreted Design

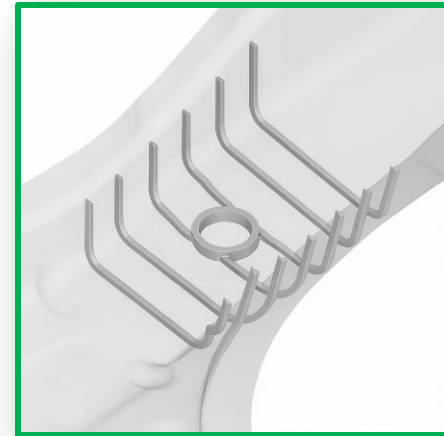

4.5kN/mm

0.09kg

Rear 3D reinforcement

0.21 kg

2.3kN/mm

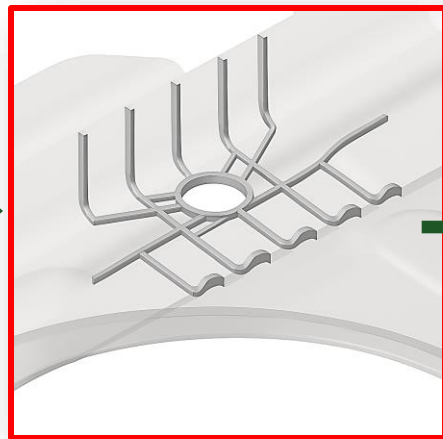
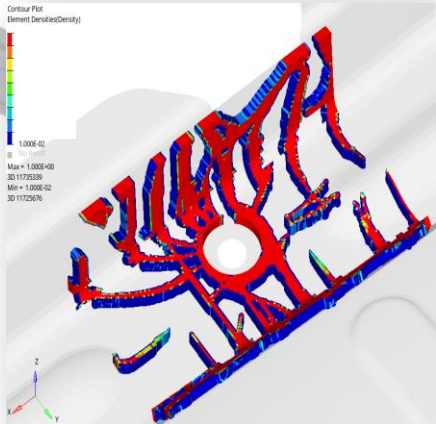

Limitation on Stamping and process constraints

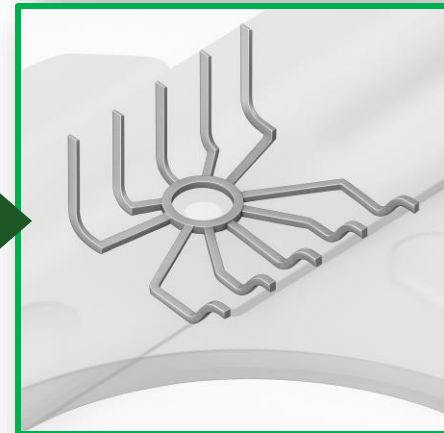

Feasible for Stamping and process constraints

0.04kg

2.3kN/mm

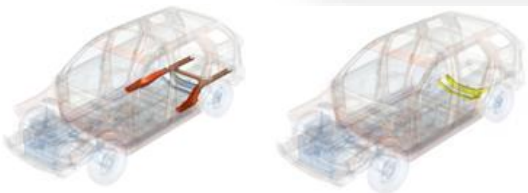

Rib Height Sensitivity

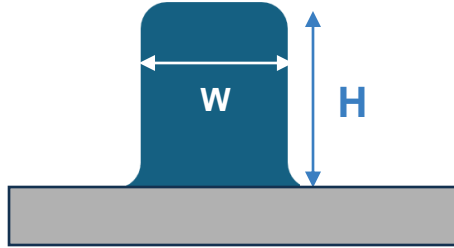

| Side | Attribute | Modality | |
|-------|---------------------------|----------------|----------------------------|
| | | Patch + Reinf. | 3D Reinf. (Variable H x W) |
| Front | Reinf. Weight (kg) | 0.16 | 0.09 |
| | Z-Displacement (mm) | 0.024 | 0.022 |
| | Z-Local Stiffness (kN/mm) | 4.2 | 4.5 |
| Rear | Reinf. Weight (kg) | 0.21 | 0.04 |
| | Z-Displacement (mm) | 0.043 | 0.044 |
| | Z-Local Stiffness (kN/mm) | 2.3 | 2.3 |

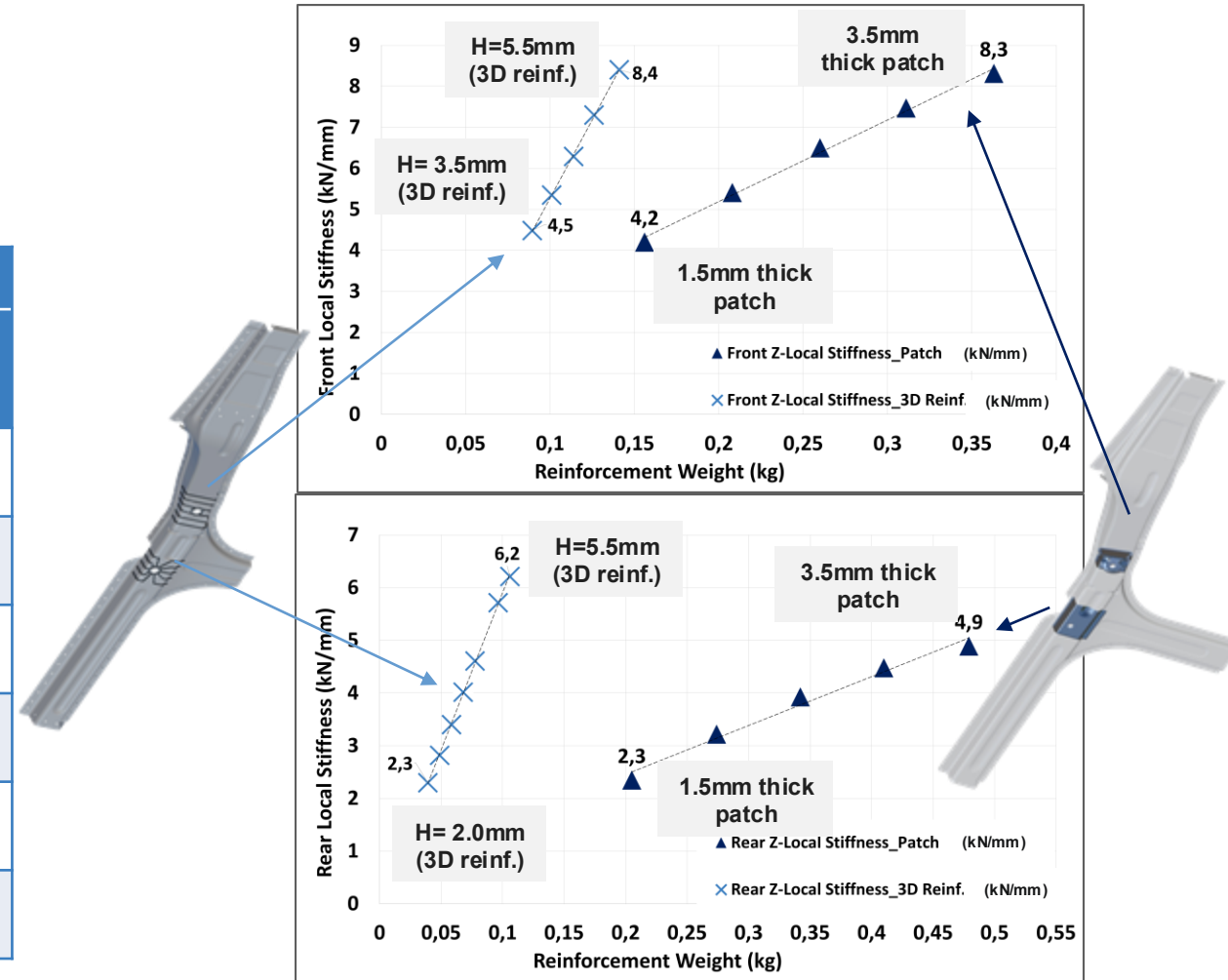

Multitude of variations evaluated to improve on local stiffness for optimized weight to performance ratio

Global Stiffness



Rear H-Frame MPI Solution + Patch & Reinf.

3D Reinforced H-Frame MPI Solution

Bending

Torsion

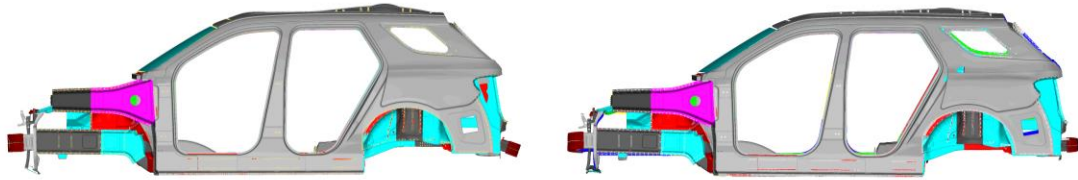

Bending

Torsion

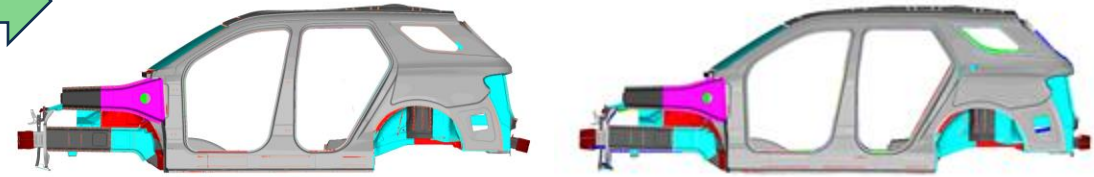

Bending

Torsion

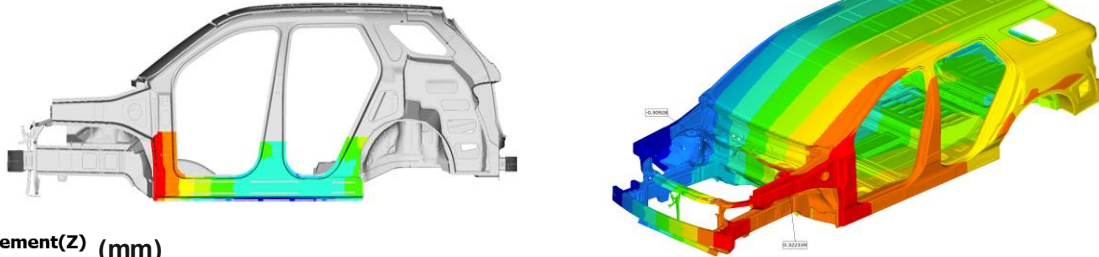

Bending

Torsion

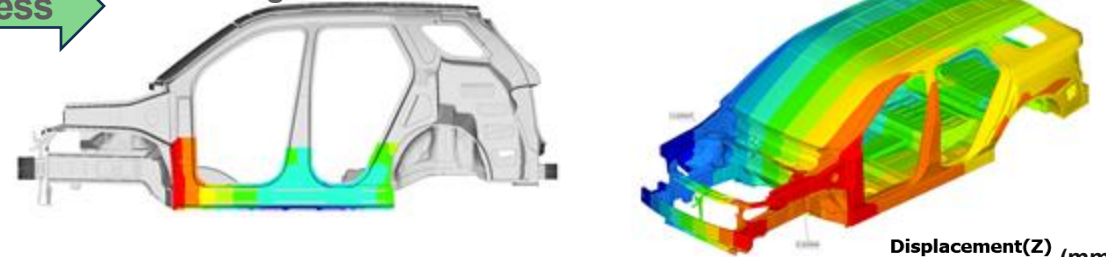

Displacement(Z) (mm)
Analysis system

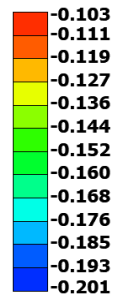

Bending

| Load case | Patch Reinforced H-Frame MPI | 3D Reinforced H-Frame MPI | Units |
|--|------------------------------|---------------------------|-------|
| Modal (1 st mode) – Bending | 40.4 | 40.5 (+0.1%) | Hz |
| Modal (1 st mode) – Torsion | 45.2 | 45.2 (0%) | Hz |
| Stiffness – Bending | 21.1 | 21.1 (0%) | kN/mm |
| Stiffness – Torsion | 33.4 | 33.3 (-0.1%) | kNm/° |

Displacement(Z) (mm)
Analysis system

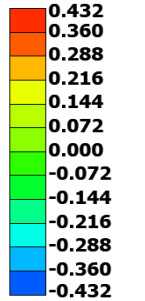

Torsion

3D reinforced H-frame MPI results are validated using global stiffness load cases on full vehicle

Rear Crash – FMVSS 305

 Rear H-Frame MPI Solution + Patch Reinforcements

 3D Reinforced H-Frame MPI Solution

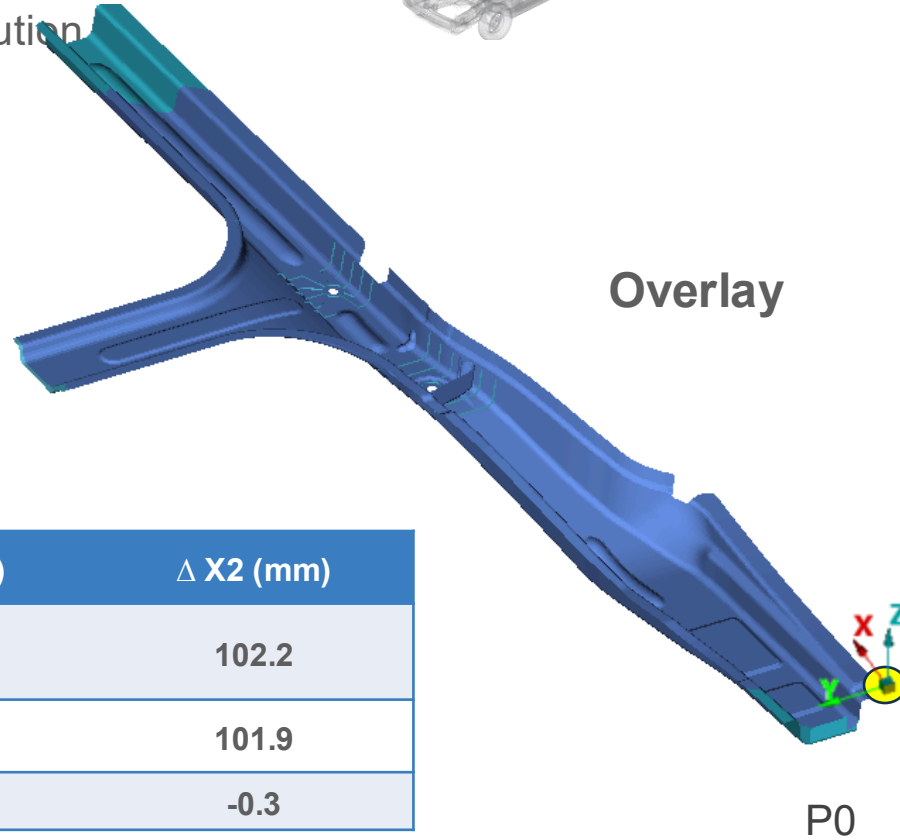
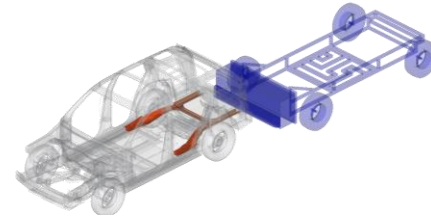
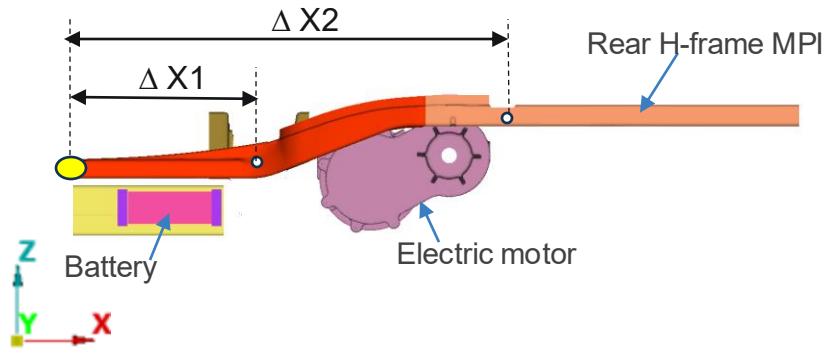

 Rear H-Frame MPI Solution + Patch Reinforcements

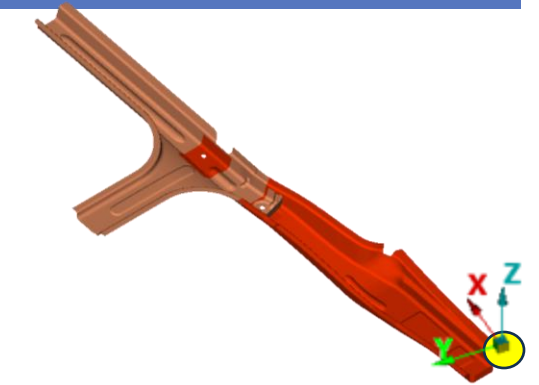

 3D Reinforced H-Frame MPI Solution

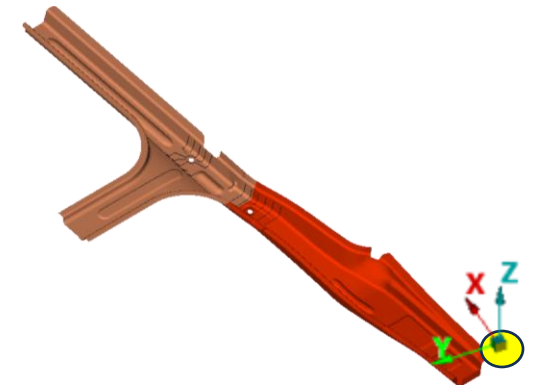

| Design | $\Delta X1$ (mm) | $\Delta X2$ (mm) |
|--|------------------|------------------|
| Rear H-Frame MPI Solution + Patch Reinforcements | 45.7 | 102.2 |
| 3D Reinforced H-Frame MPI Solution | 44.9 | 101.9 |
| Delta | -0.8 | -0.3 |

The kinematics and intrusions for both designs are comparable

The Need for Local Stiffness Tuning



What Changes by Variant?

- ✓ **Curb weight and Load cases**
(powertrain, battery, AWD, towing)
- ✓ **NVH targets**
- ✓ **Ride & Handling Character**
- ✓ **Crash & Rating requirements**
- ✓ **Regional usage & durability demands**



Why Local Stiffness?

- ✓ **Meet variant performance targets** on common underbody
- ✓ **Avoid global over-design**, mass and cost penalties
- ✓ **Enable differentiation** without new platforms
- ✓ **Supports late variants** and mid-cycle updates
- ✓ **Preserves platform** reuse and validation efficiency



Local stiffness tuning allows OEMs to differentiate attributes, while retaining a shared platform

Reinforcement Performance Tuning

Rear H-Frame MPI Solution
+ Patch Reinforcement

As is – design performance

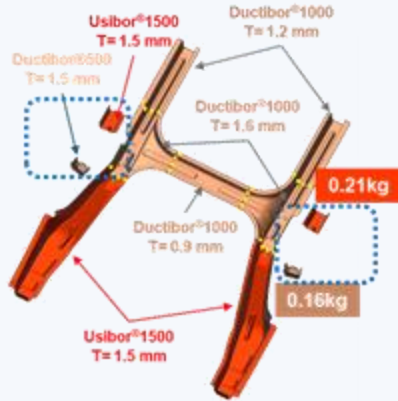

Part Weight 12.44 kg per veh.

-30% local displacement

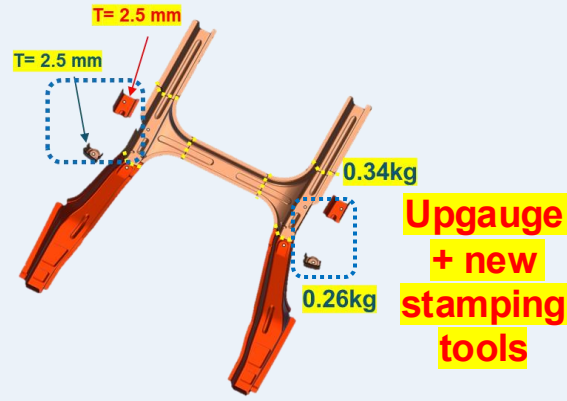

+0.46 kg per veh. (+3.7%)

-50% local displacement

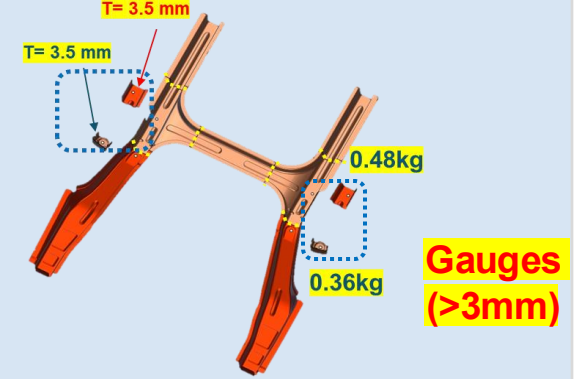

+0.94 kg per veh. (+7.6%)

Rear H-Frame MPI Solution
+ 3D Reinforced Blanks

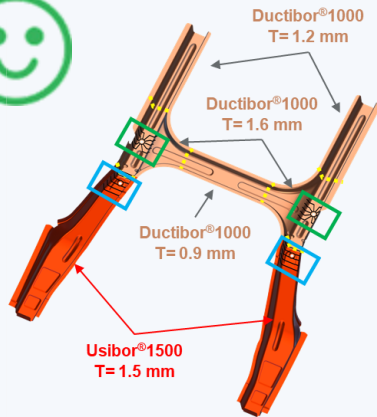

Part Weight 11.98 kg per veh.

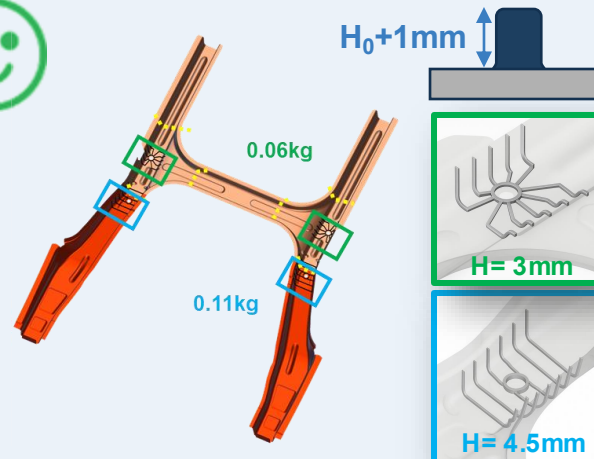
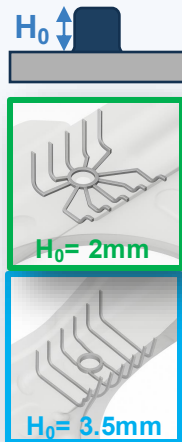

+0.08 kg per veh. (+0.7%)

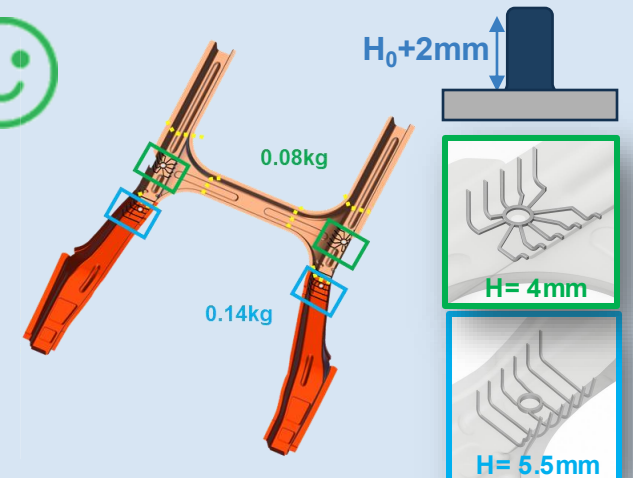

+0.18 kg per veh. (+1.5%)

3D Reinforced: No extra tooling required to increase stiffness for different variants and much more weight efficient

Optimization of Rear H-frame MPI Assembly



Patch Reinforced H-Frame MPI Solution (6-seam)

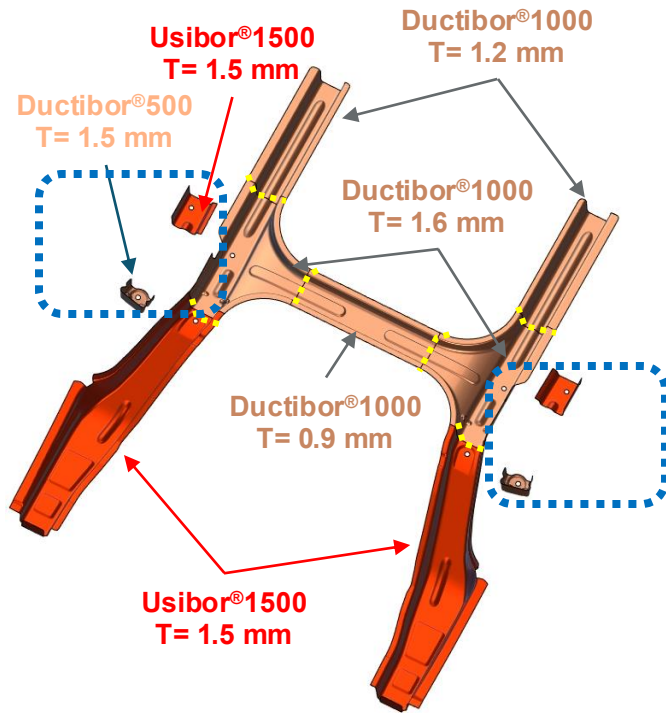

5 Parts per vehicle
Part Weight 12.44 kg/vehicle (-3.7%)

Patch Reinforced H-Frame MPI Solution (4-seam)

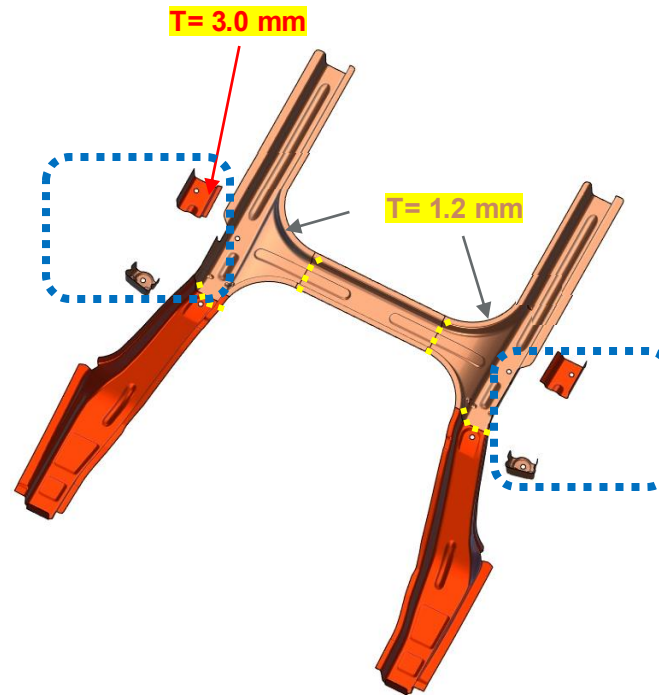

5 Parts per vehicle
Part Weight 12.01 kg/vehicle (-3.5%)

3D Reinforced H-Frame MPI Solution (Full Optimization)

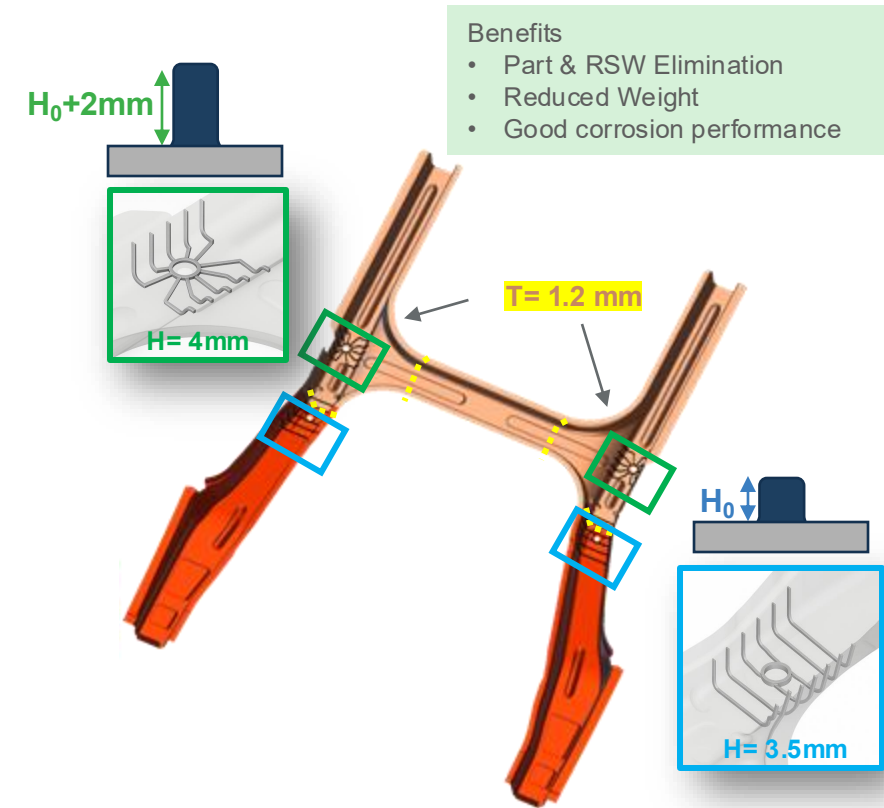

1 Part per vehicle
Part Weight 11.21 kg/vehicle (-9.9%)

3D reinforced blank MPI enables further part integration, assembly simplification, and weight savings

Cost Comparison for Optimized Rear H-frame MPI Assembly

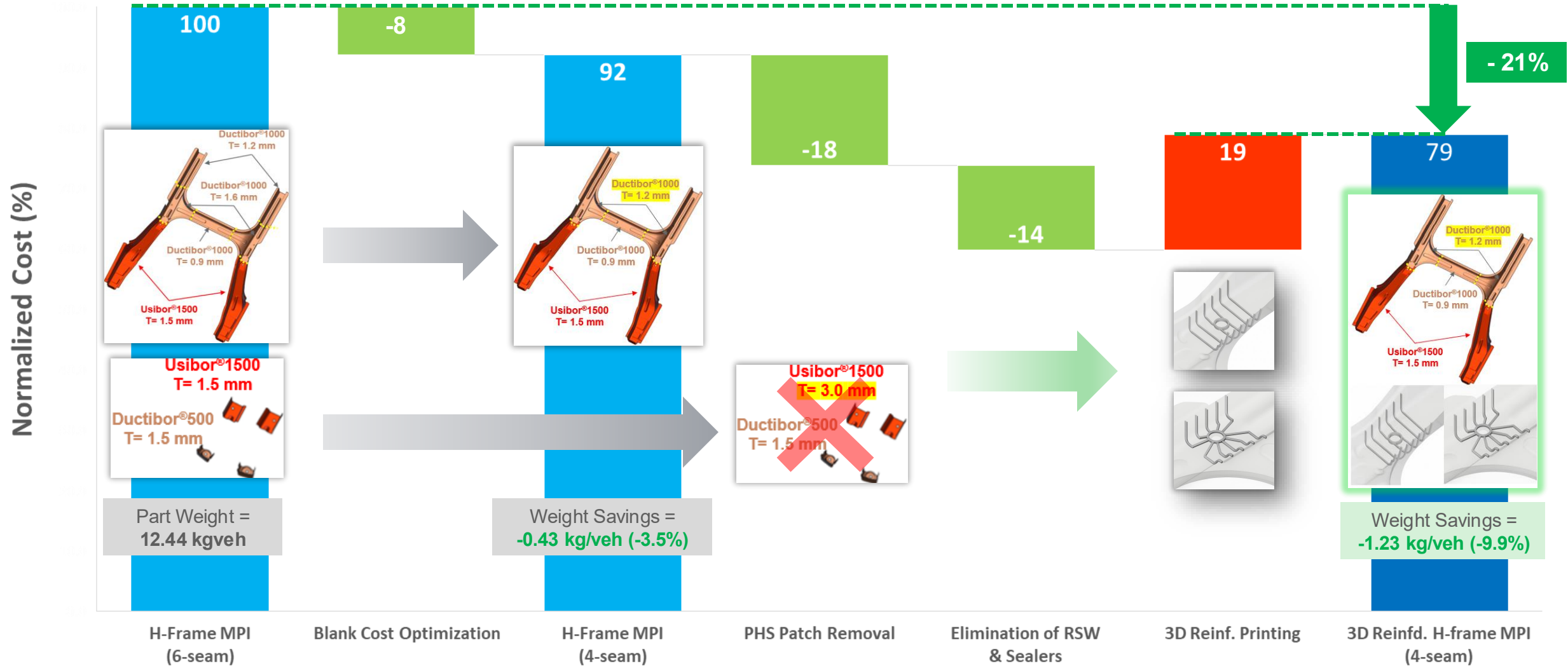

Estimated 21% cost reduction, part elimination and ~10% weight reduction

Conclusions

- ArcelorMittal 3D Reinforced Blanks + Multi Part Integration® enable the combination of assembly simplification, part reduction, cost reduction and lightweighting
- Case Study for a 3D Reinforced H-Frame MPI shows the following benefits
 - Reduced assembly part count to 1, **minus 4 parts/veh**
 - Reduced cost by **21%**
 - Reduced weight by **10%**
 - Good corrosion performance
 - Enables variant-specific local stiffness without additional tooling
- Next steps
 - Study process improvements and industrialization path
 - Study similar part integration in OEM environment

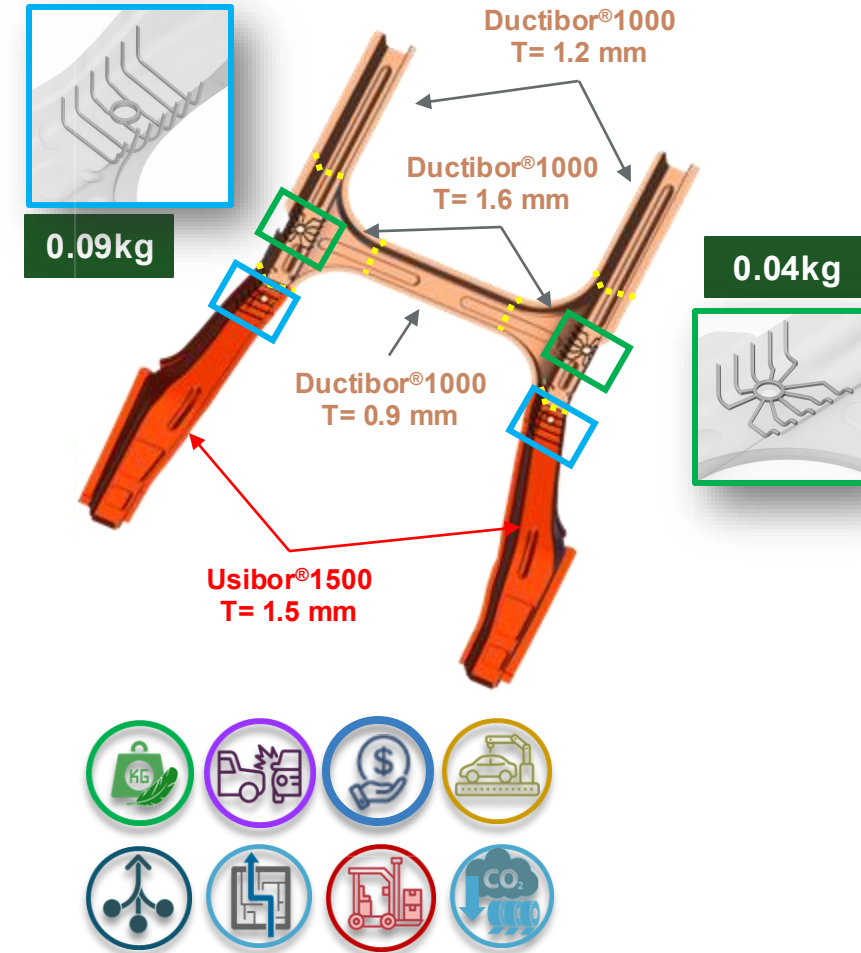

3D Reinforced Blanks with MPIs provide fastest, safest and optimized solution to automotive industry

Home of The Most Advanced Laser Welded Door Rings



GDIS

ArcelorMittal Tailored Blanks

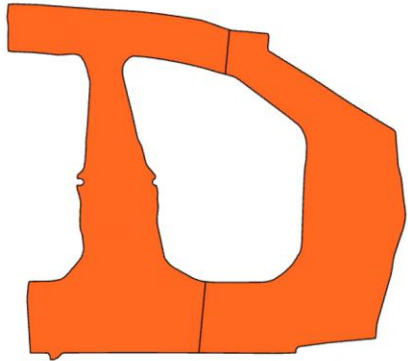

1st LWB

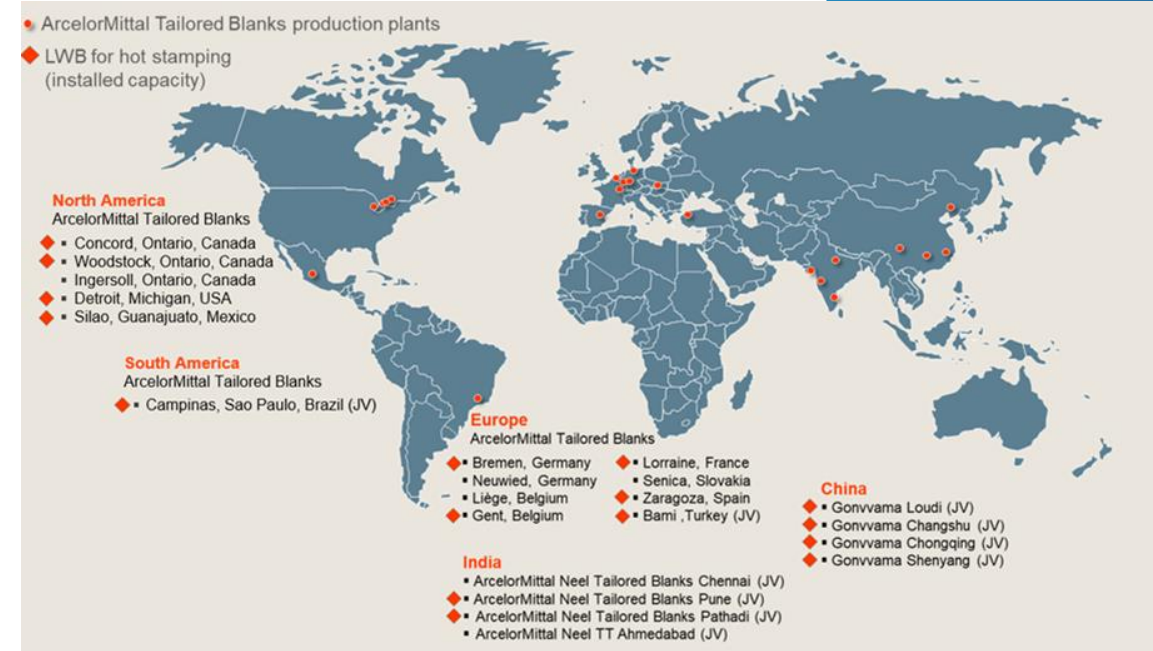

Project Team

ArcelorMittal Global R&D:
Cristian Alvarez, Shayma Aloui

ArcelorMittal Tailored Blanks NA:
Gagan Tandon, Nachiket Gokhale, Tejas Chillale, Sebastian Busch



Stop by our booth for more information!

AMTB is a leading global supplier of laser welded blanks – Safer, Stronger, Lighter, Greener Solutions