



# ROBOCUT 2026



**Quality, innovation and performance**

Superior on every level



**ROBOCUT**

# INTRODUCING ROBOCUT

Challenging conditions demand the unequalled **ALL-TERRAIN CAPABILITY** of McConnell remote control. Now there is a new ROBOCUT range, designed from the ground up, to meet the challenges of the toughest working environments.

The McConnell ROBOCUT range takes a tried and tested concept and builds on it with vision, innovation and the most advanced technology to lead the market.

Thriving in challenging terrain, hazardous areas and restricted-access zones, McConnell's ROBOCUT range helps you work faster, smarter and harder than ever before.

MADE IN BRITAIN  
Distributed worldwide 



## CONTENTS

Introducing ROBOCUT .....	2-3	Autosteer Technology.....	18-19	Attachments.....	42-47
Game Changer .....	4-5	The Remote Control Range .....	20-21	Machine Options.....	48-49
The Benefits of Remote Control Technology .....	6-7	Fine Turf Mowers		Why McConnell?.....	50-51
Safe, Productive Working.....	8-9	ROBOCUT S300 .....	22-25		
All-Terrain Capability.....	10-11	ROBOCUT S300E.....	26-29		
Superior Performance .....	12-13	All-Terrain Mowers			
Greater Output.....	14-15	ROBOCUT T400 / T500.....	30-35		
Precise Control.....	16-17	ROBOCUT T600 / T800.....	36-41		

**Please Note:** Due to continual product development, the information in this brochure is subject to change at any time. McConnell Limited assumes no responsibility for any inaccuracies, errors or omissions and reserves the right to change specifications without notice.

# GAME CHANGER

Designed for the most challenging conditions, the all new ROBOCUT is superior on every level. The range comprises of six models; from the Fine Turf ROBOCUT S300 Slope Mower with 28 horsepower through to the All-Terrain ROBOCUT T800 Tool Carrier with 75 horsepower.

The new models boast more power, an advanced feature set and GPS Autosteer option for greater output, safety and control.

## GREATER WORK OUTPUT

With the increased horsepower, ROBOCUT can now be fitted with flailheads up to 1.9m\* resulting in substantially higher output.



## RANGE OVERVIEW



### ROBOCUT S300

- 28hp (21kw) Vanguard petrol engine
- 150m working range
- 55° working angle
- 1.1m rotary mulching deck



### ROBOCUT S300E

- 48v, 14kWh Vanguard electric battery
- 150m working range
- 55° working angle
- 1.1m rotary mulching deck



### ROBOCUT T400

- 40hp (29kw) Yanmar diesel engine
- 150m working range
- 55° working angle
- Choice of attachments



### ROBOCUT T500

- 50hp (36kw) Perkins diesel engine
- 150m working range
- 55° working angle
- Choice of attachments



### ROBOCUT T600

- 60hp (45kw) Hatz diesel engine
- 150m working range
- 55° working angle
- Hydraulic head floatation system
- Choice of attachments



### ROBOCUT T800

- 75hp (56kw) Hatz diesel engine
- 150m working range
- 55° working angle
- Hydraulic head floatation system
- Choice of attachments



THE BENEFITS OF  
**REMOTE  
CONTROL  
TECHNOLOGY**

McConnel's range of remote control machines and attachments enables you to tackle jobs with confidence that used to be labour-intensive, time-consuming and potentially dangerous. With outstanding stability, intuitive finger-tip controls and a safe working range of up to 150m, these revolutionary machines allow you to work faster, smarter and harder than ever before.

**IMPROVED SAFETY**

ROBOCUT boosts safety by removing operators from steep-sided, dangerous and restricted-access zones. Capable of tackling slopes of 55 degrees, ROBOCUT has a working range of 150m and is up to 25 times more productive than manual cutting.

**ALL TERRAIN CAPABILITY**

McConnel's remote control range is built around a low-centre-of-gravity design which makes it ideal for tackling steep-sided banks. Every single component is specially positioned to ensure the machine delivers the best in stability.

**VERSATILITY**

McConnel continues to expand its range of attachments, offering a tool for almost every challenge. From snow clearance to forestry and grass cutting to quarry maintenance, McConnel can provide a safe and productive remote control solution.

**OUTPUT**

Created to tackle the toughest terrain, McConnel's ROBOCUT range features the latest engine technology, providing greater performance than ever before. New engines provide up to 75% more power resulting in market leading power-to-weight ratio.





# SAFE PRODUCTIVE WORKING

Thriving in challenging terrain, hazardous areas, and restricted-access zones, the ROBOCUT range help the operator work faster, smarter and harder than ever before and provide a safe and productive remote control solution.

ROBOCUT boosts safety by removing operators from the danger zone. With outstanding stability, a low centre of gravity and a safe working range of up to 150m, the machines combine power with exceptional manoeuvrability and intuitive control.

Whether you're tackling steep-sided slopes up to 55 degrees, riverbanks, culverts, working close to electric pylons, or mowing in restricted areas like railway embankments and military complexes the machines deliver safety, efficiency and consistent performance.





# ALL-TERRAIN CAPABILITY



McConel's innovative remote control range is built around a low-centre-of-gravity design which makes it ideal for tackling steep-sided banks. Every single component is specially positioned to ensure the machine delivers the best in stability.

Intuitive potentiometer system ensures precise proportional control from 0 to 100%. The more you press forward on the joystick the faster the machine travels.

Built-in steering bias to the left and the right compensates for bank angles and allows precise straight-ahead carriage.

The bias can be adjusted manually at the touch of a single button.

Cleated rubber tracks or optional heavy-duty spike tracks provide extra grip. A self-tightening system ensures consistent reliability and prevents excessive wear and tear.



50 ▲ 50

### 50/50 WEIGHT DISTRIBUTION

Perfect 50/50 weight distribution for maximum stability and manoeuvrability in challenging terrain.\*



55°  
**SLOPE  
CAPACITY  
IN ANY DIRECTION**



-   
**POWER**
-   
**FUEL EFFICIENCY**
-   
**OUTPUT**
-   
**SAFETY**
-   
**GRADIENT**
-   
**PRECISION & CONTROL**
-   
**GPS AUTOSTEER**

# SUPERIOR

# PERFORMANCE



All McConel ROBOCUT's are fitted with engine technology which have been developed in partnership with OEM manufacturers specifically for working on steep gradients of 55 degrees whilst meet latest emission legislation.

The S300 model is equipped with a 28 horsepower VANGUARD Electronic Fuel Injection (EFI) engine.

The T400 and T500 models are fitted with powerful 40 horsepower YANMAR and 50 horsepower PERKINS engines respectively, both Stage V specification.

Both the T600 and T800 models are fitted with Hatz Stage V engines delivering 60 & 75 horsepower respectively.\* These Hatz engines provide up to 75% more power over the T400, resulting in market leading power-to-weight ratio and also have lower levels of emissions.

The combination of high horsepower and low weight is vital for working on steep slopes and challenging terrain giving ROBOCUT unrivalled performance.

The increase in horsepower to 60hp and 75hp also enables wider 1.9m flailheads to be fitted for up to 40% more output compared to the 1.3m flailhead.

Fuel efficiency has also improved by 20% and coupled with twice the fuel capacity enables up to six hours continuous operation between refills.

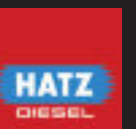

\* EU Models only



# GREATER OUTPUT

Created to tackle the toughest terrain, McConel's ROBOCUT range features the latest engine technology that provides greater performance than ever before. New engines provide up to 75% more power resulting in market leading power-to-weight ratio.

The ROBOCUT 60hp and 75hp machines with increased horsepower enable wider 1.9m (+46% increase in width) flailheads to be fitted for greater output.

#### INCREASED FUEL EFFICIENCY

Fuel efficiency has also improved by 20% and coupled with twice the fuel capacity enables up to six hours of continuous operation between refills.\*

#### STAYSAFE FLAILHEAD HOOD

A new StaySafe flailhead hood control system comes as standard on T600 and T800 models and ensures safe working when mowing alongside highways.\*



## ROBOCUT

### ATTACHMENT FLOATATION

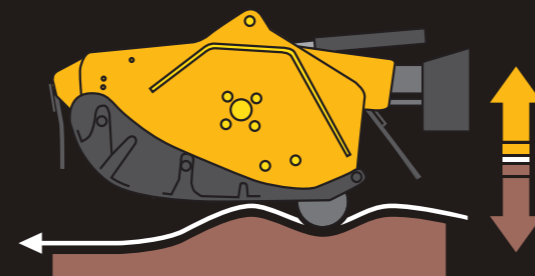

ROBOCUT T600 & T800 are both fitted with a fully programmable hydraulic attachment floatation system that ensures optimum performance in all conditions.

## ROBOCUT S300

### BI-DIRECTIONAL ROTARY MULCHING DECK



The S300 features a specially designed 1.1m bi-directional rotary mulching deck for cutting in either direction. Ideal for producing a quality cut and attractive finish in fine turf applications such as parks and gardens, whilst tough enough to be used for extensive mowing of heavy grass.



## WIDER CUTTING WIDTHS

**T400 & T500** - Available with 1.3m grass flailhead, 1.3m heavy-duty flailhead, 1.3m forestry and 1.3m mulcher flailheads.

**T600 & T800** - Flailheads available include a 1.3m & 1.6m grass flailhead, 1.6m & 1.9m heavy duty flailhead and 1.3m & 1.6m forestry and mulcher flailheads.

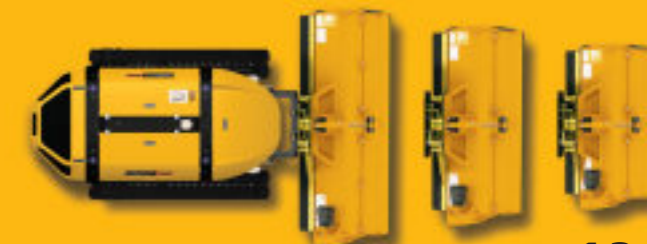

**1.9m**  
(75")

**1.6m**  
(63")

**1.3m**  
(51")



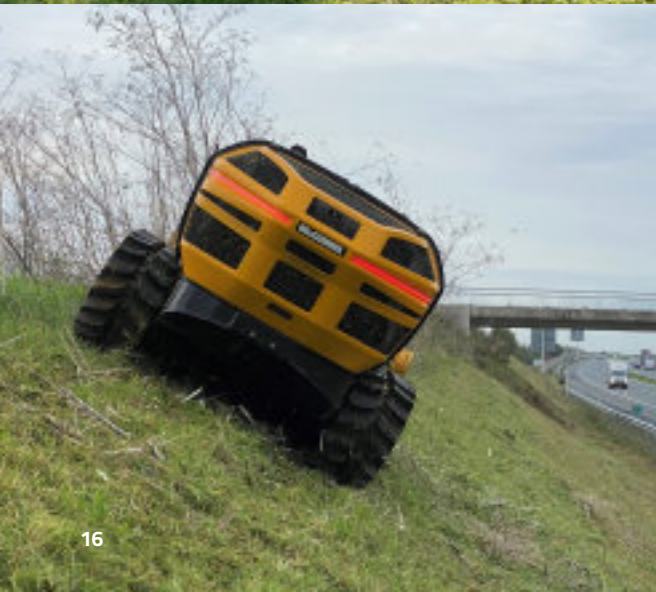

# PRECISE CONTROL

Intuitive and easy-to-master, the controls of McConnell's ROBOCUT range are lightweight, easy to learn, and offer a working range of 150m.

Two large joysticks provide control of motion, steering and attachment control, while key features such as gearing, rotor speed, speed sensitivity, radiator self-cleaning and emergency stop can all be accessed at the touch of a button.

The new remote control unit features an informative, high visibility digital display providing valuable feedback to the operator including machine engine RPM, engine temperature and signal strength.

### ROBO-READY BATTERY

ROBOCUT's new ROBO-READY battery dock simultaneously stores and charges one of the two remote control battery packs for quick and convenient change in field for reduced downtime.



## POWER AT YOUR FINGER TIPS



### ACTIVATION DISPLAY

The ROBOCUT ACTIVATION display panel enables the operator to customise and personalise their own settings and the ability to provide a full 'over the phone' diagnostic service.

- Integrated and programmable LED lights (pre-set with 14 default ISO standards). Selectable from ACTIVATION display panel.
- Cycle through various screen options, designed with the operator in mind.
- Default attachment settings selectable from ACTIVATION display panel.
- ACTIVATION display panel enables operators to configure machine and view vital statistics and error codes.





# AUTOSTEER TECHNOLOGY

For the first time GPS Autosteer is available for ROBOCUT – developed in conjunction with Trimble, a world leader in a wide range of positioning technologies.

GPS Autosteer enables operators to control precise cutting to an accuracy of 25mm from up to 150 metres away, eliminating wasteful overlap with each pass, dramatically increasing productivity.\*

## GREATER OUTPUT

Huge advances in output and efficiency are achieved when GPS Autosteer is enabled because even at long working distances the full width of the cutting head is being utilised.

## IMPROVED SAFETY

Automatic guidance also allows the operator to work accurately from a greater distance, enabling them to control the machine from a safer vantage point.



## PLOTTING THE MOST EFFICIENT SOLUTION

Using ROBOCUT Autosteer is quick, simple and intuitive:

- **Plot area** by simply travelling or mowing around the perimeter.
- **Identify any obstacles** within the mowing area by travelling or mowing around them.
- **Select direction of travel** to give the most efficient cutting path with fewest turns and longest runs.
- **Save and store** the data for future use.

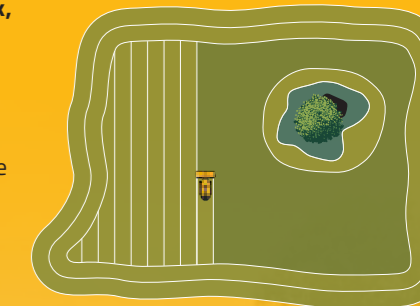

**ROBOCUT**

# INTRODUCING THE ROBOCUT RANGE

With outstanding stability, intuitive fingertip controls and an effective remote control range of up to 150m, ROBOCUT makes light work of jobs that used to be time-consuming, labour-intensive and potentially dangerous.

The range comprises of six machines; from the Fine Turf ROBOCUT S300 Slope Mower with 28 horsepower and hybrid electric drive through to the All-Terrain ROBOCUT T800 Tool Carrier with 75 horsepower.



**MADE IN BRITAIN**  
Distributed worldwide



**ROBOCUT / S300** P22 - 25

- 28hp (21kw) Vanguard petrol engine
- 150m working range
- 55° working angle
- 1.1m rotary mulching deck



**ROBOCUT / S300E** P26 - 29

- 48v, 14kWh Vanguard electric battery
- 150m working range
- 55° working angle
- 1.1m rotary mulching deck



**ROBOCUT / T400** P30 - 35

- 40hp (29kw) Yanmar diesel engine
- 150m working range
- 55° working angle
- Choice of attachments



**ROBOCUT / T500** P30 - 35

- 50hp (36kw) Perkins diesel engine
- 150m working range
- 55° working angle
- Choice of attachments



**ROBOCUT / T600** P36 - 41

- 60hp (45kw) Hatz diesel engine
- 150m working range
- 55° working angle
- Hydraulic head floatation system
- Choice of attachments



**ROBOCUT / T800** P36 - 41

- 75hp (56Kw) Hatz diesel engine
- 150m working range
- 55° working angle
- Hydraulic head floatation system
- Choice of attachments



# FINE TURF SLOPE MOWER ROBOCUT S300

The ROBOCUT S300 delivers outstanding performance and mowing efficiency. Featuring a new and powerful Vanguard 28hp engine, with low fuel consumption and low emissions, combined with hybrid electric drive to deliver smooth operation.



**POWER**  
Powerful 28hp engine.



**FUEL EFFICIENCY**  
Low fuel consumption and low emissions.



**OUTPUT**  
High output due to intuitive bi-directional cutting capabilities.



**SAFETY**  
Removes the operator from the danger zone.



**GRADIENT**  
Work on slopes up to 55°.



**PRECISION & CONTROL**  
Fully proportional remote control.



**GPS AUTOSTEER**  
Ensures maximum productivity, improved safety and more efficient working.



**ROBOCUT / S300**

# KEY PRODUCT FEATURES

## LOW GROUND PRESSURE

Creates minimal surface disturbance.

## BODY PANELS

Fully enclosed panels keep grass and debris out.

## 50/50 WEIGHT DISTRIBUTION

Gives maximum stability and optimum handling on slopes.

## MULCHING CONTROL

Full remote control of mulching deck functions including on-off and height adjustment.

## SMOOTH ELECTRIC DRIVE MOTOR

Provides precise control & variable speed.

## REDUCE THE NEED FOR TURNING WITH BI-DIRECTIONAL CUTTING

Bi-directional cutting reduces the need for turning, dramatically improves productivity and minimises surface disturbance.

## 28 HP PETROL ENGINE

Vanguard Commercial Power petrol engine with efficient electronic fuel injection.



## LIGHT AND COMPACT

Allows quick and convenient transportation.

## MULTI-FUNCTION REMOTE CONTROL

Precise proportional remote control with a working range of 150m.



## GPS READY

Plug & Play GPS Autosteer Ready

## LOW CENTRE OF GRAVITY

And wide track widths enables working on slopes up to 55°.



## SPECIFICATION

### ROBOCUT S300

#### ENGINE

Make	Vanguard 810cc Electronic Fuel Injection (EFI) engine
Horsepower	28hp (21kw)
Fuel	Petrol
Fuel tank capacity	10 litre, removable tank
Drive	48V AC electric motor to final reduction
Maximum noise levels	98dB(A)
Speed	0-7 kph
Compliance	ANSI B71.4 safety regulation

#### MULCHING DECK

Cutting width	1.1m (3' 7")
Cutting height	25mm - 150mm (1" - 6")
Programmable low height setting	Standard
Bi-directional cutting	Standard
Updraft, mulching blades	Standard
Drive type	Direct shaft drive with electric clutch
Blade tip-speed	5650m/min

#### TRACKS

Universal rubber	Standard - max working angle 55°
Self-tightening	Spring
Length (axle to axle)	1000mm (3' 3")

#### REMOTE CONTROLS

Working range	150m
Frequency	434MHz (certified by CE legislation)
Battery	2 x rechargeable batteries
Proportional joysticks	Standard

#### DIMENSIONS

Overall width	1500mm (4' 11")
Overall length	1510mm (4' 11")
Overall height	765 - 890mm (2' 6" - 2' 11")

#### WEIGHT

ROBOCUT	535kg (1,179lbs)
---------	------------------

**Please Note:** Due to continual product development, the information in this brochure is subject to change at any time. McConnel Limited assumes no responsibility for any inaccuracies, errors or omissions and reserves the right to change specifications without notice.

**ROBOCUT - SUPERIOR ON EVERY LEVEL**

**ROBOCUT** / **S300E**

# THE ULTIMATE ALL-ELECTRIC SLOPE MOWER

# ROBOCUT S300E

The ROBOCUT S300E provides outstanding performance and mowing efficiency. A total of four direct drive electric motors deliver smooth progressive power to both the tracks and cutting decks. The 48V, 14kWh Vanguard battery pack supplies up to 4 hours running time for uninterrupted operation.



#### POWER

Powerful  
48V AC Direct drive.



#### EFFICIENCY

Up to 4 hours running  
time on a single charge.



#### OUTPUT

High output  
due to intuitive  
bi-directional  
cutting capabilities.



#### SAFETY

Removes the  
operator from the  
dange zone.



#### GRADIENT

Work on  
slopes up  
to 55°.



#### PRECISION & CONTROL

Fully proportional  
remote control.



#### GPS AUTOSTEER

Ensures maximum  
productivity, improved  
safety and more  
efficient working.

**ROBOCUT S300E**

# KEY PRODUCT FEATURES

Designed for fine turf applications the S300E is smaller, lighter and simply more efficient.

## LOW GROUND PRESSURE

Creates minimal surface disturbance.

## DIRECT DRIVE

Electric motors directly drive blades for optimal efficiency.

## 50/50 WEIGHT DISTRIBUTION

Gives maximum stability and optimum handling on slopes.

## MULCHING CONTROL

Full remote control of mulching deck functions including on-off and height adjustment.

## REDUCED NOISE

Quieter and more efficient mowing.

## SMOOTH ELECTRIC DRIVE MOTOR

Provides precise control & variable speed.

## REDUCE THE NEED FOR TURNING WITH BI-DIRECTIONAL CUTTING

Bi-directional cutting reduces the need for turning, dramatically improves productivity and minimises surface disturbance.



## OEM BATTERY

48V, 14kWh (2 x 7kWh Vanguard Batteries)

## 2000 CYCLES

Till 80% initial battery capacity.

## ZERO EMISSIONS

No harmful emissions emitted.

## MULTI-FUNCTION REMOTE CONTROL

Precise proportional remote control with a working range of 150m.



## GPS READY

Plug and play GPS Autosteer ready.

## LOW CENTRE OF GRAVITY

And wide track widths enables working on slopes up to 55°.

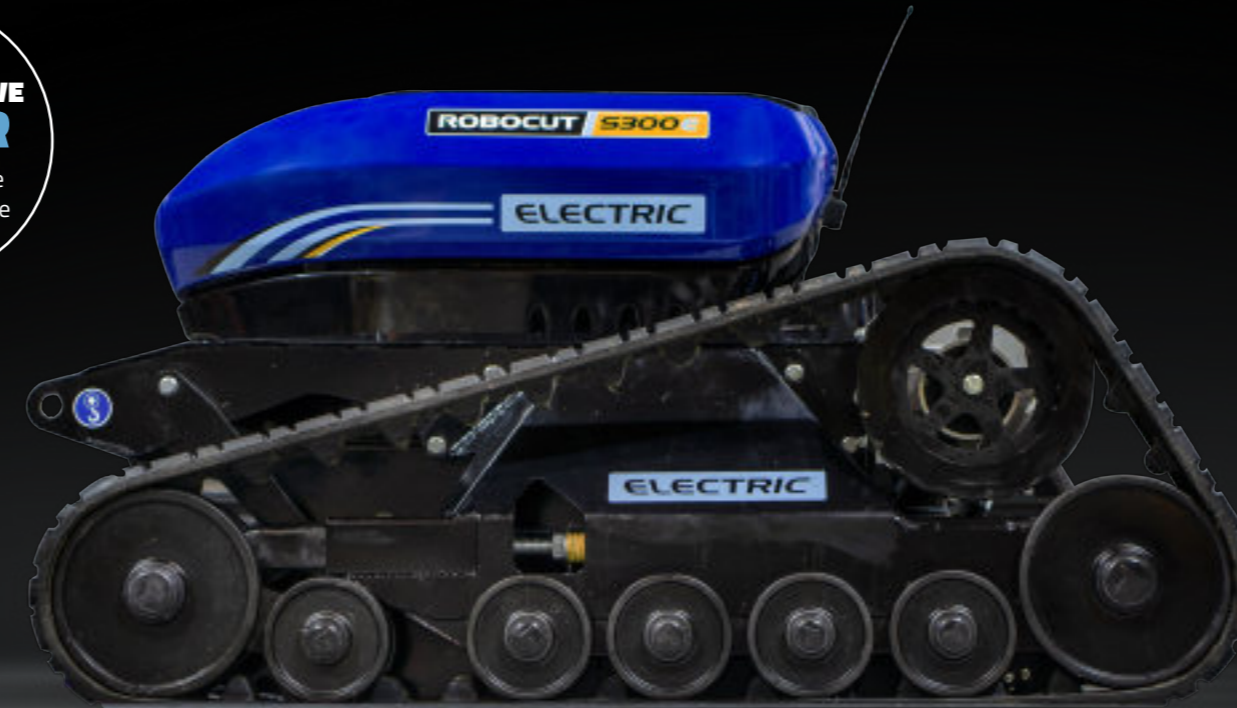

**ROBOCUT - SUPERIOR ON EVERY LEVEL**

## SPECIFICATION

### ROBOCUT S300E

#### POWER

Make	Vanguard Lithium
Power	48V, 14kWh (2x 7kWh)
Runtime	Upto 4 hours continuous
Charging	8-hour single charger, 4-hours dual chargers
Drive	48V AC electric motor to final reduction
Speed	0-7 kph
Compliance	ANSI B71.4 safety regulation

#### MULCHING DECK

Cutting width	1.1m (3' 4")
Cutting height	25mm - 150mm (1" - 6")
Programmable low height setting	Standard
Bi-directional cutting	Standard
Updraft, mulching blades	Standard
Drive type	Direct motor through electric motor
Blade tip-speed	5650m/min

#### TRACKS

Universal rubber	Standard - max working angle 55°
Self-tightening	Spring
Length (axle to axle)	1000mm (3' 3")

#### REMOTE CONTROLS

Working range	150m
Frequency	434MHz (certified by CE legislation)
Battery	2 x rechargeable batteries
Proportional joysticks	Standard

#### DIMENSIONS

Overall width	1500mm (4' 11")
Overall length	1510mm (4' 11")
Overall height	830 - 955mm (2' 9" - 3' 2")

#### WEIGHT

ROBOCUT	565kg (1,246 lbs)
---------	-------------------

**Please Note:** Due to continual product development, the information in this brochure is subject to change at any time. McConnel Limited assumes no responsibility for any inaccuracies, errors or omissions and reserves the right to change specifications without notice.



# THE ALL NEW ROBOCUT T400 & T500

Challenging conditions demand the unequalled ALL-TERRAIN CAPABILITY of the McConel remote control ROBOCUT T400 and T500.

Thriving in challenging terrain, hazardous areas, and restricted access zones, McConel's new ROBOCUT T400 and T500 machines help you work faster, smarter and harder than ever before.



**POWER**  
Powerful  
40hp & 50hp  
engines.



**FUEL  
EFFICIENCY**  
Fuel efficient  
Stage V engines.



**OUTPUT**  
High output  
to tackle the toughest  
tasks efficiently.



**SAFETY**  
Removes the  
operator from the  
danger zone.



**GRADIENT**  
Work on  
slopes up  
to 55°.



**PRECISION  
& CONTROL**  
Fully proportional  
remote control.



**ROBOCUT T400**

**ROBOCUT T500**

# KEY PRODUCT FEATURES

The McConel ROBOCUT T400 & T500 utilise the latest advancements in technology to deliver the ultimate in remote controlled machinery.

## NEW DESIGN

Fully enclosed metal body panels keep out grass and debris.

## IMPROVED EFFICIENCY

28.5 litre fuel tank capacity for long running time.

## TWIN ROLL-BARS

Strengthened and exposed twin roll bars for increased protection.

## POWER-TO-WEIGHT RATIO

Leading power-to-weight ratio on the market.

## MULTI-FUNCTION REMOTE CONTROL

Precise proportional remote control with a working range of 150m.

## LED LIGHTING

Integrated LED daylight running lights.

## OEM DIESEL ENGINES (40HP & 50HP)

Developed and tested specifically for ROBOCUT.

## ROBO-READY BATTERY DOCK

Simultaneously stores and charges spare battery.

## LOW CENTRE OF GRAVITY

For maximum stability on steep slopes.

## TWO AUXILIARY SERVICES

Fitted as standard.



ROBOCUT - SUPERIOR ON EVERY LEVEL

**ROBOCUT T400**

**ROBOCUT T500**

# TECHNICAL SPECIFICATION



## SPECIFICATION

	ROBOCUT T400	ROBOCUT T500
<b>ENGINE</b>		
Make	YANMAR, Stage V, 3 cylinder	PERKINS, Stage V, 3 cylinder
HP	40hp (29kw) @ 3000rpm	50hp (36kw) @ 3000rpm
Torque	105Nm	166Nm
Fuel	Diesel	Diesel
Fuel tank capacity	28.5 litres	28.5 litres
Water-cooled radiator	3 core heavy duty	3 core heavy duty
Self-cleaning (reversible fan)	Standard	Standard
Transmission	Fine control hydrostatic	Fine control hydrostatic
Maximum noise levels	80dB(A)	80dB(A)
<b>HYDRAULICS</b>		
Independent flailhead circuit	Closed circuit piston Max 55 l/min @ 280Bar	Closed circuit piston Max 55 l/min @ 300Bar
Independent track drive circuit	2 x closed circuit pistons Max 57 l/min (Total) @ 250Bar	2 x closed circuit pistons Max 57 l/min (Total) @ 250Bar
Aux service	2 double acting auxiliary service, non proportional 12 l/min @ 190Bar	2 double acting auxiliary service, non proportional 12 l/min @ 190Bar
Independent intercooler	Standard	Standard
Oil tank capacity	11 litres	11 litres
Attachment lift capacity	500kg	500kg
<b>TRACKS</b>		
Standard rubber tracks	Compatible ~ max working angle 40°	Compatible ~ max working angle 40°
Super rubber tracks	Standard ~ max working angle 55°	Standard ~ max working angle 55°
Studded tracks (with optional spike)	Optional ~ max working angle 55°	Optional ~ max working angle 55°
Self-tightening	Standard	Standard
Length (axle to axle)	1192mm	1192mm
<b>REMOTE CONTROLS</b>		
Working range	150m	150m
Frequency	2.4GHz (certified by CE legislation)	2.4GHz (certified by CE legislation)
Battery	Interchangeable, rechargeable, two with each unit charge on machine	Interchangeable, rechargeable, two with each unit charge on machine
Proportional joysticks	Standard	Standard
<b>DIMENSIONS</b>		
Overall width	1310mm	1310mm
Overall length (without attachment)	1960mm	1960mm
Overall height	1120mm	1120mm
<b>WEIGHT</b>		
ROBOCUT	1120kg	1190kg
Flailhead / Attachment	Depends on size / type	Depends on size / type

	ROBOCUT T400	ROBOCUT T500
<b>PERFORMANCE</b>		
Potentiometer speed control (0 to 100%)	1st gear (low range) Forward and back 0 - 4 km/h  2nd gear (low range) Forward and back 0 - 7 km/h	1st gear (low range) Forward and back 0 - 4 km/h  2nd gear (low range) Forward and back 0 - 7 km/h
<b>FLAILHEAD / ATTACHMENT</b>		
Oil flow	55 l/min	55 l/min
Pressure	280 bar	280 bar
Rotor speed	3300 rpm	3300 rpm
Front and rear flaps	Standard	Standard
Flails	Y – Flails for cutting grass and light wood up to 30mm diameter  J (hammer) – Flails for cutting thick grass and wood up to 50mm diameter	Y – Flails for cutting grass and light wood up to 30mm diameter  J (hammer) – Flails for cutting thick grass and wood up to 50mm diameter
Rotor width	1.3 to 1.6m	1.3 to 1.6m
Roller diameter	100mm	100mm
Cutting height range (via roller adjustment)	20mm - 85mm (5 position mechanical slotted float). Flailhead can be lifted to cut higher	20mm - 85mm (5 position mechanical slotted float). Flailhead can be lifted to cut higher
Hydraulic lift	-300mm to +400mm	-300mm to +400mm
Floation (angle)	14° up and down (+/-)	14° up and down (+/-)
<b>ATTACHMENT OPTIONS</b> (See pages 42-47)		
ROBO-FLAILHEAD	1.3m (51") flailhead	1.3m (51") flailhead
ROBO-FLAILHEAD HD	1.3m (51") flailhead	1.3m (51") flailhead
ROBO-MULCHER	1.3m forestry flailhead	1.3m forestry flailhead
ROBO-FOREST	1.3m fixed-tooth forestry flailhead	1.3m fixed-tooth forestry flailhead
ROBO-STUMP GRINDER	370mm cutting wheel diameter (inc teeth)	370mm cutting wheel diameter (inc teeth)
ROBO-ROTARY MOWER	1.5m cutting width	1.5m cutting width
ROBO-CUTTERBAR HD	1.7m cutting width	1.7m cutting width
ROBO-TRENCHER	Digs to a depth of 0.9m and a width of 200mm	Digs to a depth of 0.9m and a width of 200mm
ROBO-RAKE	1.6m working width	1.6m working width
ROBO-LAND BLADE	1.7m working width	1.7m working width
ROBO-SNOW BLADE	1.7m working width	1.7m working width
ROBO-BRUSH	1.5m working width	1.5m working width
ROBO-ROTARY TILLER	1.45m working width	1.45m working width
ROBO-SNOW BLOWER	1.42m working width	1.42m working width
ROBO-FORK	Adjustable working width	Adjustable working width
ROBO-TOE-TIP BUCKET	1.3m working width	1.3m working width
ROBO-GRAPPLE BUCKET	1.3m working width	1.3m working width

**Please Note:** Due to continual product development, the information in this brochure is subject to change at any time. McConnel Limited assumes no responsibility for any inaccuracies, errors or omissions and reserves the right to change specifications without notice.

**ROBOCUT** 

# THE ALL NEW **ROBOCUT T600 & T800**

Designed for the most challenging conditions, the all-terrain capability of the all new ROBOCUT T600 and T800 surpass all expectations. An exciting new ground up design incorporates the very latest advancements in technology.

The new models boast more power, an advanced feature set and GPS Autosteer option for greater output, safety and control.



**POWER**

More powerful than before – increase of 40% (T600) and 75% (T800).



**FUEL EFFICIENCY**

20% more efficient on fuel so better value on each job.



**OUTPUT**

More coverage – get almost double the output in a day.



**SAFETY**

New flailhead safety control system.



**GRADIENT**

Work on slopes up to 55° (alarm at 50° and automatic shut-off at 70°).



**PRECISION & CONTROL**

28% increase in track drive pressure plus improved hydraulic float system.



**GPS AUTOSTEER**

Ensures maximum productivity, improved safety and more efficient working



**ROBOCUT T600**

**ROBOCUT T800**

# KEY PRODUCT FEATURES

The McConel ROBOCUT T600 and T800 machines utilise the latest advancements in technology to deliver the ultimate in remote controlled machinery.

## NEW DESIGN

Removable enclosed body panels for ease of access to engine bay.

## HYDRAULIC HEAD FLOATATION SYSTEM

Revolutionary floatation system can be programmed to suit different attachments and conditions.

## FLAILHEAD SAFETY CONTROL SYSTEM

For hydraulic front hood with screen notifications.

## DIGITAL CONTROL SYSTEM WITH ON MACHINE BATTERY CHARGER

The Digital Control System is supplied with two batteries that can be charged on board ROBOCUT.

## UPGRADED ROLL-BARS

Strengthened and exposed twin roll bars for increased protection.

## LED LIGHTING

Integrated programmable four corner LED warning beacons and daylight running lights.

## ANCILLARY LAYOUT IMPROVED

Key engine components relocated for easier servicing.

## HATZ DIESEL ENGINES (60HP & 75HP)

OEM modified and tested specifically for ROBOCUT.

## PERFECT 50/50 WEIGHT DISTRIBUTION

Maximum stability in all terrain achieved by ROBOCUT thanks to perfect 50/50 weight distribution.

## LOWERED CENTRE OF GRAVITY

Greater slope capacity and twin roll bars.



**50 ▲ 50**

## 50/50 WEIGHT DISTRIBUTION

A new common chassis design provides a lower centre of gravity and perfect 50/50 weight distribution for maximum stability & manoeuvrability in challenging terrain.



# GPS AUTOSTEER CAPABILITY

## REVOLUTIONARY REMOTE GUIDANCE

ROBOCUT can be enabled with GPS Autosteer technology - developed in conjunction with Trimble - allowing it to automatically steer to within 25mm accuracy along it's cutting route for huge advances in output and efficiency.



**ROBOCUT - SUPERIOR ON EVERY LEVEL**

**ROBOCUT T600**

**ROBOCUT T800**

# TECHNICAL SPECIFICATION

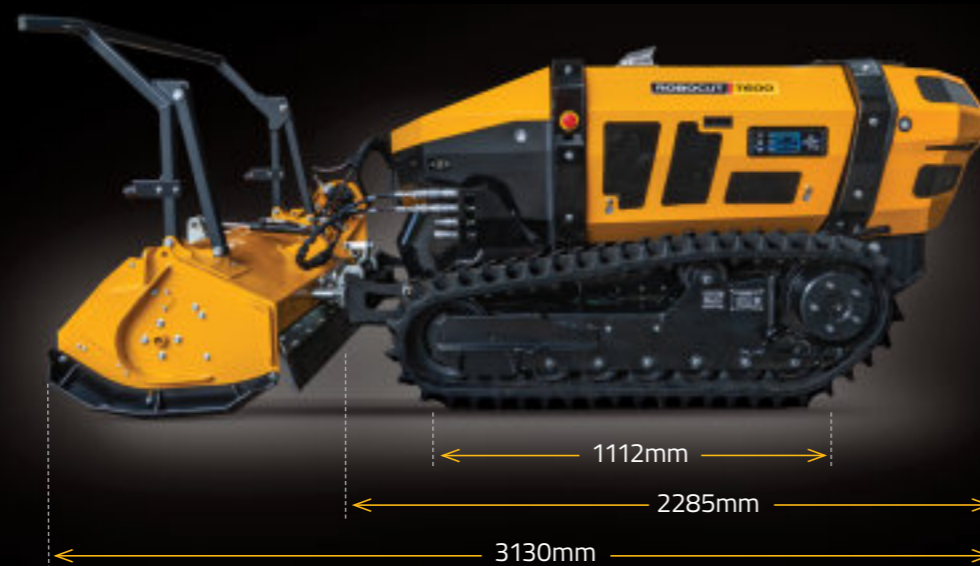
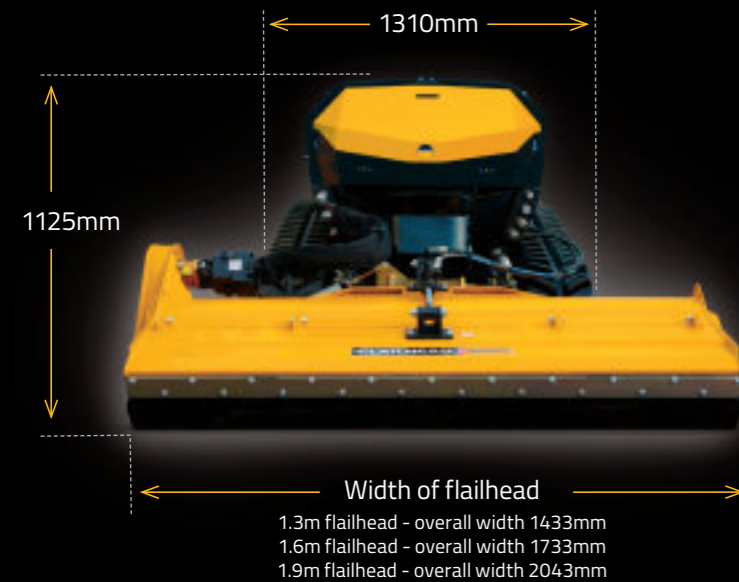

## SPECIFICATION

	ROBOCUT T600	ROBOCUT T800
<b>ENGINE</b>		
Make	HATZ, Stage V, 3 cylinder, turbo	HATZ, Stage V, 4 cylinder, turbo
HP	60hp (45kw) @ 2800rpm	75hp (56kw) @ 2800rpm
Torque	185Nm	240Nm
Fuel	Diesel	Diesel
Fuel tank capacity	38 litres	38 litres
Water-cooled radiator	3 core heavy duty	3 core heavy duty
Self-cleaning (reversible fan)	Standard manual and automatic	Standard manual and automatic
Transmission	Fine control hydrostatic	Fine control hydrostatic
Maximum noise levels	77dB(A)	77dB(A)
<b>HYDRAULICS</b>		
Independent flailhead circuit	Closed circuit piston Max 59 l/min @ 2800 rpm 350Bar	Closed circuit piston Max 95 l/min @ 2800 rpm 350Bar
Independent track drive circuit	2 x closed circuit piston Max 62 l/min @ 2800 rpm 300Bar	2 x closed circuit piston Max 62 l/min @ 2800 rpm 300Bar
Aux service	2 double acting auxiliary service non proportional 16 l/min @ 210Bar	2 double acting auxiliary service non proportional, 16 l/min @ 210Bar
Independent intercooler	Standard	Standard
Oil tank capacity	20 litres (40 litres held in system)	20 litres (40 litres held in system)
Attachment lift capacity	550kg	550kg
<b>TRACKS</b>		
Standard rubber tracks	Standard ~ max working angle 40°	Standard ~ max working angle 40°
Super rubber tracks	Optional ~ max working angle 55°	Optional ~ max working angle 55°
Studded tracks (with optional spike)	Optional ~ max working angle 55°	Optional ~ max working angle 55°
Self-tightening	Standard	Standard
Length (axle to axle)	1192mm	1192mm
<b>REMOTE CONTROLS</b>		
Working range	150m	150m
Frequency	2.4GHz (certified by CE legislation)	2.4GHz (certified by CE legislation)
Battery	Interchangeable, rechargeable, two with each unit charge on machine	Interchangeable, rechargeable, two with each unit charge on machine
Proportional joysticks	Precise proportional control	Precise proportional control
GPS Autosteer	Ready - Plug & Play GPS Autosteer	Ready - Plug & Play GPS Autosteer
<b>DIMENSIONS</b>		
Overall width	1310mm	1310mm
Overall length (without attachment)	2285mm	2285mm
Overall height	1125mm	1125mm
<b>WEIGHT</b>		
ROBOCUT	1420kg	1460kg
Flailhead / Attachment	Depends on size / type	Depends on size / type

	ROBOCUT T600	ROBOCUT T800
<b>PERFORMANCE</b>		
Potentiometer speed control (0 to 100%)	1st gear (low range) Forward and back 0 - 4 km/h  2nd gear (low range) Forward and back 0 - 7 km/h	1st gear (low range) Forward and back 0 - 4 km/h  2nd gear (low range) Forward and back 0 - 7 km/h
<b>FLAILHEAD / ATTACHMENT</b>		
Oil flow	59 l/min	95 l/min
Pressure	350 bar	350 bar
Rotor speed	3300 rpm	3300 rpm
Front and rear flaps	Standard	Standard
Flails	Y - Flails for cutting grass and light wood up to 30mm diameter  J (hammer) - Flails for cutting thick grass and wood up to 50mm diameter	Y - Flails for cutting grass and light wood up to 30mm diameter  J (hammer) - Flails for cutting thick grass and wood up to 50mm diameter
Rotor width	1.3 to 1.9m	1.3 to 1.9m
Roller diameter	100mm	100mm
Cutting height range (via roller adjustment)	20mm - 85mm (5 positions) Flailhead can be lifted to cut higher	20mm - 85mm (5 positions) Flailhead can be lifted to cut higher
Hydraulic lift	-300mm to +400mm	-300mm to +400mm
Floatation (angle)	14° up and down (+/-)	14° up and down (+/-)
<b>ATTACHMENT OPTIONS</b> (See pages 42-47)		
ROBO-FLAILHEAD	1.3m (51") flailhead	---
ROBO-FLAILHEAD HD	1.3m (51"), 1.6m (63") & 1.9m (75") flailhead	1.3m (51"), 1.6m (63") & 1.9m (75") flailhead
ROBO-FOREST	1.3m and 1.6m fixed-tooth forestry flailhead	1.3m and 1.6m fixed-tooth forestry flailhead
ROBO-MULCHER	1.3m and 1.6m forestry flailhead	1.3m and 1.6m forestry flailhead
ROBO-STUMP GRINDER	370mm and 400mm cutting wheel diameter	400mm cutting wheel diameter (inc teeth)
RECOVERY-WINCH KIT	For ROBOCUT recovery, 4,084kg max load	For ROBOCUT recovery, 4,084kg max load
ROBO-ROTARY MOWER	1.5m cutting width	---
ROBO-CUTTERBAR HD	1.7m cutting width	---
ROBO-TRENCHER	Digs to a depth of 0.9m and a width of 200mm	---
ROBO-RAKE	1.6m working width	---
ROBO-LAND BLADE	1.7m working width	1.7m working width
ROBO-SNOW BLADE	1.7m working width	1.7m working width
ROBO-BRUSH	1.5m working width	---
ROBO-ROTARY TILLER	1.45m working width	---
ROBO-SNOW BLOWER	1.42m working width	---
ROBO-FORK	Adjustable working width	Adjustable working width
ROBO-TOE-TIP BUCKET	1.3m working width	1.3m working width
ROBO-GRAPPLE BUCKET	1.3m working width	1.3m working width

**Please Note:** Due to continual product development, the information in this brochure is subject to change at any time. McConnel Limited assumes no responsibility for any inaccuracies, errors or omissions and reserves the right to change specifications without notice.

# ATTACHMENTS

Far more than just an all-terrain mowing machine, ROBOCUT comes with a choice of attachments, transforming it into a remote control work platform that increases safety, productivity and efficiency.



## RANGE OF ATTACHMENTS

ROBO-FLAILHEAD.....	43	ROBO-RAKE.....	45
ROBO-FLAILHEAD HD.....	43	ROBO-LAND BLADE.....	46
ROBO-MULCHER.....	43	ROBO-SNOW BLADE.....	46
ROBO-FOREST.....	43	ROBO-BRUSH.....	46
ROBO-STUMP GRINDER.....	44	ROBO-ROTARY TILLER.....	46
RECOVERY-WINCH KIT.....	44	ROBO-SNOW BLOWER.....	47
ROBO-ROTARY TURF MOWER.....	45	ROBO-FORK.....	47
ROBO-CUTTERBAR HD.....	45	ROBO-TOE-TIP BUCKET.....	47
ROBO-TRENCHER.....	45	ROBO-GRAPPLE BUCKET.....	47

**17**  
ATTACHMENTS  
AVAILABLE

## ROBOCUT ATTACHMENTS

### ROBO-FLAILHEAD

A high-performance flailhead with back-to-back grass 'Y' flails. The attachment is driven by a 3000 rpm energy-efficient spiral rotor and can tackle everything from grass and shrubs up to 3cm diameter.

#### Technical specification

- 1.3m cutting width
- Hydraulic front hood
- Grass cutting flails
- Full width rear roller
- 30mm cutting capacity
- 20-85mm cutting height
- +/- 14 degree head angling and floatation
- 3000 rpm rotor speed
- 240kg weight



Optional Hydraulic Side Shift  
Provides extra 60cm movement

Compatible with:  
ROBOCUT T400  
ROBOCUT T500  
ROBOCUT T600

### ROBO-FLAILHEAD HD

A high-performance Heavy-Duty flailhead that comes with a choice of hammer or back-to-back grass 'Y' flails. The attachment is driven by a 2350 rpm energy-efficient spiral rotor and can tackle everything from grass to gorse.

#### Technical specification

- 1.3m, 1.6m\* and 1.9m\* cutting widths
- Hydraulic front hood
- Choice of grass cutting flails or hammer flails
- Full width rear roller
- 30mm cutting capacity
- 20-85mm cutting height
- +/- 14 degree head angling and floatation
- 2350 rpm rotor speed



\* 1.6m & 1.9m ROBOCUT T600 & T800 only

Compatible with:  
ROBOCUT T400  
ROBOCUT T500  
ROBOCUT T600  
ROBOCUT T800

### ROBO-MULCHER

Ultra heavy-duty 1.3m and 1.6m forestry head that's ideal for tackling everything from heavy overgrowth to small saplings.

#### Technical specification

- 1.3m and 1.6m\* cutting widths
- Ultra heavy duty hammer flails
- Unique high-performance rotor allows flails to swing through 360 degrees
- Hydraulic front hood
- Reinforced steel push bar
- 100mm cutting capacity
- 3000 rpm rotor speed
- +/- 14 degree head angling and floatation
- 315kg weight



\* 1.6m ROBOCUT T600 & T800 only

Compatible with:  
ROBOCUT T400  
ROBOCUT T500  
ROBOCUT T600  
ROBOCUT T800

### ROBO-FOREST

A high-performance 1.3m and 1.6m fixed-tooth forestry flailhead that has the power to tackle everything from overgrowth to small trees.

#### Technical specification

- 1.3m and 1.6m\* cutting widths
- Hard-wearing tungsten carbide fixed teeth
- Hydraulic front hood
- Reinforced steel push bar
- 100mm cutting capacity
- 3000 rpm rotor speed
- +/- 14 degree head angling and floatation
- 355kg weight



\* 1.6m ROBOCUT T600 & T800 only

Compatible with:  
ROBOCUT T400  
ROBOCUT T500  
ROBOCUT T600  
ROBOCUT T800

## ROBO-STUMP GRINDER

Compatible with:  
**ROBOCUT T400**  
**ROBOCUT T500**  
**ROBOCUT T600**

A robust stump grinder featuring a high-speed 370mm cutting wheel armed with 12 heavy duty tungsten teeth. The machine can handle tree and bush roots and is ideal for dealing with unwanted stumps in previously inaccessible areas.

### Technical specification

- 12 hard-wearing tungsten carbide teeth
- High-performance 1800rpm rotor
- 370mm cutting wheel diameter (inc teeth)
- Automatic head oscillation
- Reinforced steel protective hood cover
- Protective skirt
- 92kg weight



## ROBO-STUMP GRINDER

Compatible with:  
**ROBOCUT T600**

Designed specifically for the ROBOCUT T600, this professional stump grinder delivers exceptional performance with a 400mm cutting wheel and 16 heavy-duty tungsten teeth. Featuring an oscillating arch movement and a 1.1m working width, this lightweight yet powerful 200kg machine efficiently removes stumps and trunks. Safety is ensured with a reinforced steel protective hood and a durable protective skirt.

### Technical specification

- 1.10m working width
- 16 hard-wearing tungsten carbide teeth
- 400mm cutting wheel diameter (inc teeth)
- High-performance rotor
- Automatic head oscillation
- Reinforced steel protective hood cover
- Protective skirt
- 200kg weight



## ROBO-ROTARY MOWER

Compatible with:  
**ROBOCUT T400**  
**ROBOCUT T500**  
**ROBOCUT T600**

A high-performance 1.5m rotary turf mower. Hydraulically driven with a heavy-duty belt drive and rear discharge, the deck's three rotors propel six cutting blades at 2200 rpm – delivering a fine-cut finish perfect for the horticultural, landscaping and amenities sectors.

### Technical specification

- 1.5m cutting width
- Three double cutting blades
- 10 - 70mm cutting height
- 540mm disc diameter
- Robust steel construction
- 21cc hydraulic motor
- 290 bar pressure
- 210kg weight

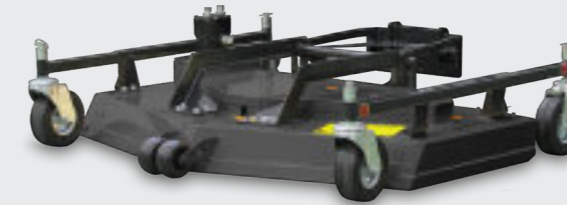

## ROBO-CUTTERBAR HD

Compatible with:  
**ROBOCUT T400**  
**ROBOCUT T500**  
**ROBOCUT T600**

A light and manoeuvrable 1.7m cutterbar with tungsten carbide, wear resistant teeth that's ideal for maintaining grass and reeds where a close cut finish is vital.

### Technical specification

- 1.7m cutting width
- 24 hard-wearing tungsten carbide teeth
- Adjustable double knife head
- 13 degree head oscillation
- 50cc hydraulic motor
- Smooth cutting action
- Reinforced skids
- 100 bar pressure
- 218kg weight



## ROBO-STUMP GRINDER

Compatible with:  
**ROBOCUT T800**

Built for the high-horsepower ROBOCUT T800, this professional duty stump grinder offers enhanced durability and power. Equipped with a 400mm cutting wheel and 16 heavy-duty tungsten teeth, the robust 250kg unit features an oscillating arch movement and a 1.1m working width, making it ideal for tackling larger stumps and trunks. Safety features include a reinforced steel protective hood and a protective skirt.

### Technical specification

- 1.10m working width
- 16 hard-wearing tungsten carbide teeth
- 400mm cutting wheel diameter (inc teeth)
- High-performance rotor
- Automatic head oscillation
- Reinforced steel protective hood cover
- Protective skirt



## RECOVERY-WINCH KIT

Compatible with:  
**ROBOCUT T600**  
**ROBOCUT T800**

Recover your ROBOCUT in the toughest conditions with a high performance, all-electric recovery winch. With a 2,042 kg load-bearing capacity - doubling to an impressive 4,084 kg using the included pulley block, the ROBOCUT recovery winch enables safe and effortless recovery.

### Technical specification

- 2,042 kg load-bearing capacity \*
- 15.2m (50ft) steel winch rope
- Heavy-duty roller fairlead
- Chassis mounted
- Metal bumper bar protection
- Can be operated via ROBOCUT remote control or via dedicated wired controller (supplied)
- 12v DC

\* 4,084 kg when used with supplied Pully Block



## ROBO-TRENCHER

Compatible with:  
**ROBOCUT T400**  
**ROBOCUT T500**  
**ROBOCUT T600**

Ideal for laying pipes or cables, the ROBO-TRENCHER will enable operators to dig narrow channels with minimal damage to the ground.

### Technical specification

- Heavy-duty tungsten carbide chain with teeth
- Digs to a depth of 0.9m and a width of 10-20cm
- Adjustable support foot controls the depth of the trench
- Reinforced steel safety guard
- Powerful hydraulic motor
- 240 bar pressure
- 260kg weight



## ROBO-RAKE

Compatible with:  
**ROBOCUT T400**  
**ROBOCUT T500**  
**ROBOCUT T600**

A mobile and manoeuvrable rake attachment designed to thrive in steep-sided terrain, ROBO-RAKE is ideal for removing cut grass from river banks.

### Technical specification

- 1.6m working width
- 40 rotating 250mm steel tines
- +/- 13 degree head angling and floatation
- Powerful dual belt drive
- Manoeuvrable 'zero-turn' wheels
- Height adjustable
- 126kg weight

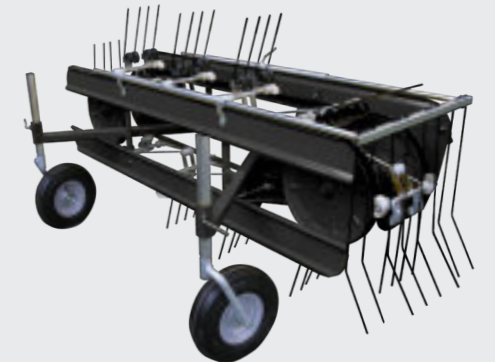

## ROBO-LAND BLADE

Ideal for maintenance of roads, streets and also the removal or transfer of dirt, leaves and other foliage or vegetation waste. The ROBO-LAND BLADE has a heavy duty steel frame equipped with a replaceable steel scraping knife, shockproof springs, support feet and wheels.

### Technical specification

- 1.7m working width
- Hydraulically adjustable blade angle
- 350mm blade height
- +/- 13 degree blade oscillation
- +/- 20 inclination angle
- Replaceable steel blade
- 170kg weight



Compatible with:  
**ROBOCUT T400**  
**ROBOCUT T500**  
**ROBOCUT T600**  
**ROBOCUT T800**

## ROBO-SNOW BLADE

Ideal for clearing snow along roads, squares, open spaces and parks. The ROBO-SNOW BLADE is hydraulically adjustable and equipped with support foot and pivoting wheels for better manoeuvrability. The scraping blade is made of steel or plastic and easily interchangeable.

### Technical specification

- 1.7m working width
- Hydraulically adjustable blade angle
- 600mm blade height
- +/- 13 degree blade oscillation
- +/- 20 inclination angle
- Replaceable steel or plastic blade
- 123kg weight



Compatible with:  
**ROBOCUT T400**  
**ROBOCUT T500**  
**ROBOCUT T600**  
**ROBOCUT T800**

## ROBO-SNOW BLOWER

Armed with a high-velocity ejection unit, the ROBO-SNOW BLOWER provides a safe and effective solution when clearing roads and paths in hard-to-reach and potentially dangerous locations.

### Technical specification

- 1.42m working width
- Powerful full-length 400mm diameter cutting ring
- Hydraulic deflector from 0-45 degrees
- Adjustable chimney +/- 100 degrees
- Protective throwing guards
- Powerful 51cc motor
- 280kg weight



Compatible with:  
**ROBOCUT T400**  
**ROBOCUT T500**  
**ROBOCUT T600**

## ROBO-FORK

Perfect for moving materials in the most challenging environments, the fork attachment enables safe and effective transportation of everything from construction materials to sand bags for flood defence.

### Technical specification

- 80cm long robust steel forks
- Adjustable working width
- 300kg lifting capacity
- Low maintenance
- Easy to use
- 80kg weight



Compatible with:  
**ROBOCUT T400**  
**ROBOCUT T500**  
**ROBOCUT T600**  
**ROBOCUT T800**

## ROBO-BRUSH

ROBO-BRUSH helps operators clear up debris quickly and easily. With a working width of 1.5m, it's fast and effective in even the most challenging terrain.

### Technical specification

- 1.5m working width
- 400mm brush diameter
- Hydraulically adjustable sweeping angle
- Powerful 650 rpm rotor
- +/- 20 degree head angling and floatation
- Hard-wearing brush
- Simple height adjustment via swivel wheels
- 150kg weight

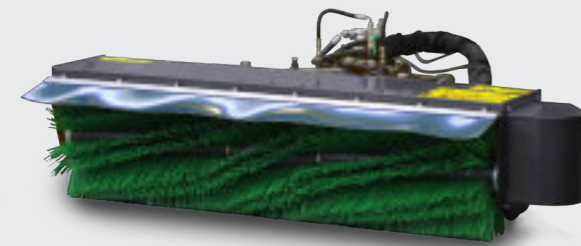

Compatible with:  
**ROBOCUT T400**  
**ROBOCUT T500**  
**ROBOCUT T600**

## ROBO-ROTARY TILLER

Designed for tilling and grading the soil, the ROBO-ROTARY TILLER is equipped with a high-performance rotor with 4 hoes per flange and adjustable slides.

### Technical specification

- 1.45m working width
- 1.6m overall width
- 28 hoes
- Adjustable skids
- 150mm max working depth
- 16.5kw motor
- 175kg weight

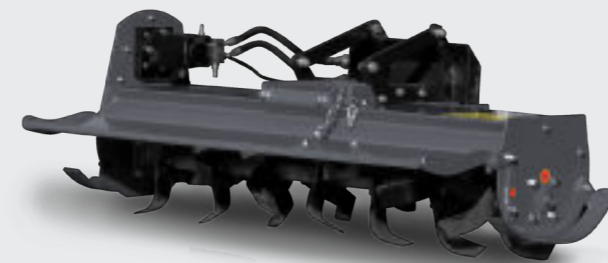

Compatible with:  
**ROBOCUT T400**  
**ROBOCUT T500**  
**ROBOCUT T600**

## ROBO-TOE-TIP BUCKET

The toe-tip bucket attachment enables safe working in a range of restricted access and hazardous environments. Rugged and reliable, the attachment is ideal for construction, demolition and military installations.

### Technical specification

- 1.3m working width
- 780mm bucket depth
- 610mm unloading height
- 47 degree tipping angle
- 300kg maximum load capacity
- 0.2 cubic metre bucket
- 170kg weight



Compatible with:  
**ROBOCUT T400**  
**ROBOCUT T500**  
**ROBOCUT T600**  
**ROBOCUT T800**

## ROBO-GRAPPLE BUCKET

A heavy-duty bucket with hydraulic grab that prevents the fall of material and makes it an ideal tool for the transfer of waste and loose vegetation.

### Technical specification

- 1.3m working width
- 830mm bucket depth
- 610mm unloading height
- 47 degree tipping angle
- 300kg maximum load capacity
- 0.15 cubic metre bucket
- 170kg weight



Compatible with:  
**ROBOCUT T400**  
**ROBOCUT T500**  
**ROBOCUT T600**  
**ROBOCUT T800**

# MACHINE OPTIONS

## GPS AUTOSTEER

GPS Autosteer is available for ROBOCUT – developed in conjunction with Trimble, a world leader in a wide range of positioning technologies.

- Enables operators to control cutting to an accuracy of 25mm from up to 150 metres away.
- Utilises full width of cutting head
- Eliminates wasteful overlap
- Dramatically increases productivity
- Improves safety as machine can be controlled from a safer vantage point.



See pages 18-19

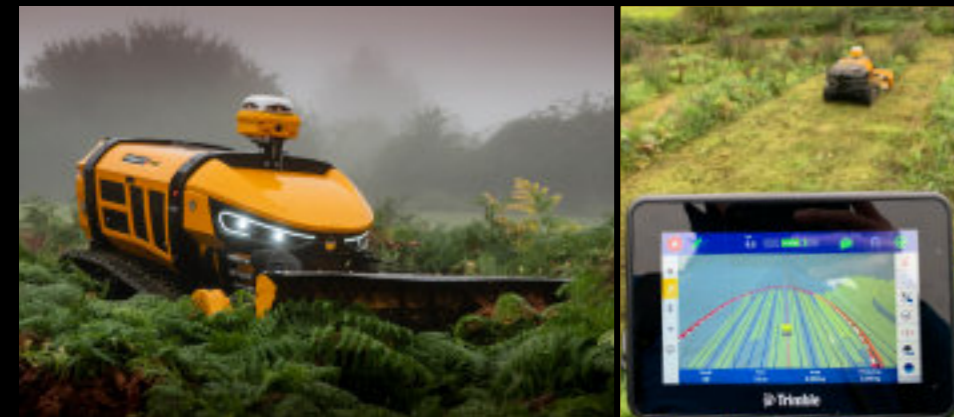

## FORESTRY GUARDS

- Heavy duty, all-metal, forestry guard kit
- Protects against hazards such as low-lying branches or foreign obstacles
- Provides complete 360 degree protection
- All guards easily moved to provide easy, tool-free access
- ROBOCUT T600 / T800 only



All panels can be easily moved for complete access for service and maintenance.

## TOW HITCH (T400 & T500)



## BALL HITCH (T600 & T800)

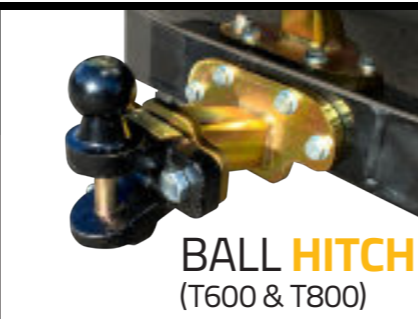

## REAR BUMPER

- Heavy duty rear bumper kit
- Protects rear of machine against damage
- Easy to attach
- ROBOCUT T600 / T800 only

## WORKING LIGHTS

- Powerful LED lights to assist task visibility
- Easily attached to top of machine
- Can be adjusted to suit requirement
- ROBOCUT T600 / T800 only



ROBOCUT has eight external mounting points integrated within the rollcage for fitment of accessories and guarding.

# ROBOCUT TRACK OPTIONS

Three track options are available for the new ROBOCUT machines. These feature a more durable design to take the punishment of harsh all-terrain work. Stiffer spring tension helps maintain constant track pressure in all terrains.

## STANDARD RUBBER TRACK

- Suitable for mowing up to 40°
- Low ground disturbance
- Hard-wearing rubber compound
- Compatible with ROBOCUT T400 & T500 models but not available to order fitted to these machines.



## SUPER RUBBER TRACK

- Suitable for slopes up to 55°
- Angled contours for extra grip
- Hard-wearing rubber compound



## STUDED TRACK (with optional spike kit)

- Suitable for steep slopes up to 55° and testing conditions such as snow and slippery ground



Available with optional spike kit. Only one spike kit required per machine.

# WHY MCCONNEL?

When you buy a McConnell ROBOCUT, you're not just buying a high-performance machine – you're also getting a first-class aftercare package that supports you through the lifespan of your product. So whether you need an urgent part, service assistance or online information on how to get the best from your machine, McConnell should always be your first choice.

Key benefits of buying your machine from McConnell include:

- An international network of dealers and distributors provides full service and support in 40 countries across the globe
- Every machine is subjected to an exhaustive performance test before being released to a customer
- A comprehensive stock of genuine replacement parts can be sent to dealers around the world via international couriers
- McConnell has a proud 80-year heritage and a proven track record of expertise in the design and manufacture of hedge-cutting and mowing technology
- From world's first to world's best – McConnell launched the first ever tractor mounted hedgecutter back in 1948 and has led the way as the number one in green maintenance ever since
- Our highly-skilled team of service professionals train hundreds of dealers every year and can offer expert support if you have an issue that can't be resolved quickly by your local dealer
- Customisation is fully supported with McConnell working with customers to help them create bespoke machines
- An online library of essential information including Operator's Guides, Parts Books, and multimedia product information is available 24/7

McConnell offers a proven product range, strong after-care support, and an international network of dealers and distributors spanning 40 countries, so if you're keen to take advantage of our high-performance products, can you afford not to choose McConnell?



## POWER ARMS

McConnell offers a comprehensive selection of Power Arms with 10 different series and 37 different models. Customers can choose from thousands of different build variations to create a personalised specification that is ideal for their needs. A wide selection of working attachments is also available from saw blades to ditch cleaners.



For more information on McConnell's full machine line-up please visit [www.mcconnel.com](http://www.mcconnel.com)



## FLAIL & ROTARY MOWERS

Whether you are looking for a flail or rotary mower, McConnell has a machine to match your needs with a choice of 12 different series and 27 machines available. The choice includes everything from 1.3m compact flail mowers through to an 8.2m high-performance flex-wing rotary mower.

## AGRIBUGGY

Unrivalled low ground pressure design, market-leading traction and stability and greater comfort are just a few of the key benefits delivered by McConnell's AgribuggyV300 power unit. The mechanical drive technology offers best-in-class traction – delivering power and braking to all four wheels simultaneously for better grip when working in wet conditions and tough terrain, allowing safe, productive working earlier and later in the year than rivals.





**SALES**

Tel: +44 (0)1584 873131  
sales@mccannel.com

**PARTS**

Tel: +44 (0)1584 876888  
parts@mccannel.com

**SERVICE**

Tel: +44 (0)1584 875848  
service@mccannel.com

**MARKETING**

Tel: +44 (0)1584 813412  
marketing@mccannel.com



**McConnel Limited**  
Temeside Works, Ludlow,  
Shropshire SY8 1JL  
United Kingdom

Tel **+44 (0)1584 873131**  
E-mail **sales@mccannel.com**  
Website **www.mccannel.com**



**100% Recyclable**  
Responsibly  
sourced paper



FM 25970

A Member of the

