

# MDL 127 LP E

Double-Wall Sound Booth | 10.3 sq ft



Shown with  
optional  
studio light

**WhisperRoom**®

# MDL 127 LP E

Double-Wall Sound Booth | 10.3 sq ft



Exterior Dimensions	5' 5" x 4' 6" x 7' 1"
Interior Dimensions	10.3 sq ft
Assembled Weight	1228 lbs (557 kg)
Assembly Time	~ 3 hours
Wall Thickness	1" MDF barrier + 1.25" air gap + 1" MDF barrier
Wall Panel Layers	Two 1" MDF barrier + 1.25" air gap + 2" foam
Door Window Thickness	3 1/8"
Door Window Layers	Dual laminated glass sets with central air gap
Window Size	12" x 30"

**Note:** Exterior dimensions exclude 5.5" ventilation duct protrusion. Height increases by 5" with the optional caster plate.

# MDL 127 LP E

Double-Wall Sound Booth | 10.3 sq ft

Top-Down Layout & Modular Panel Configuration

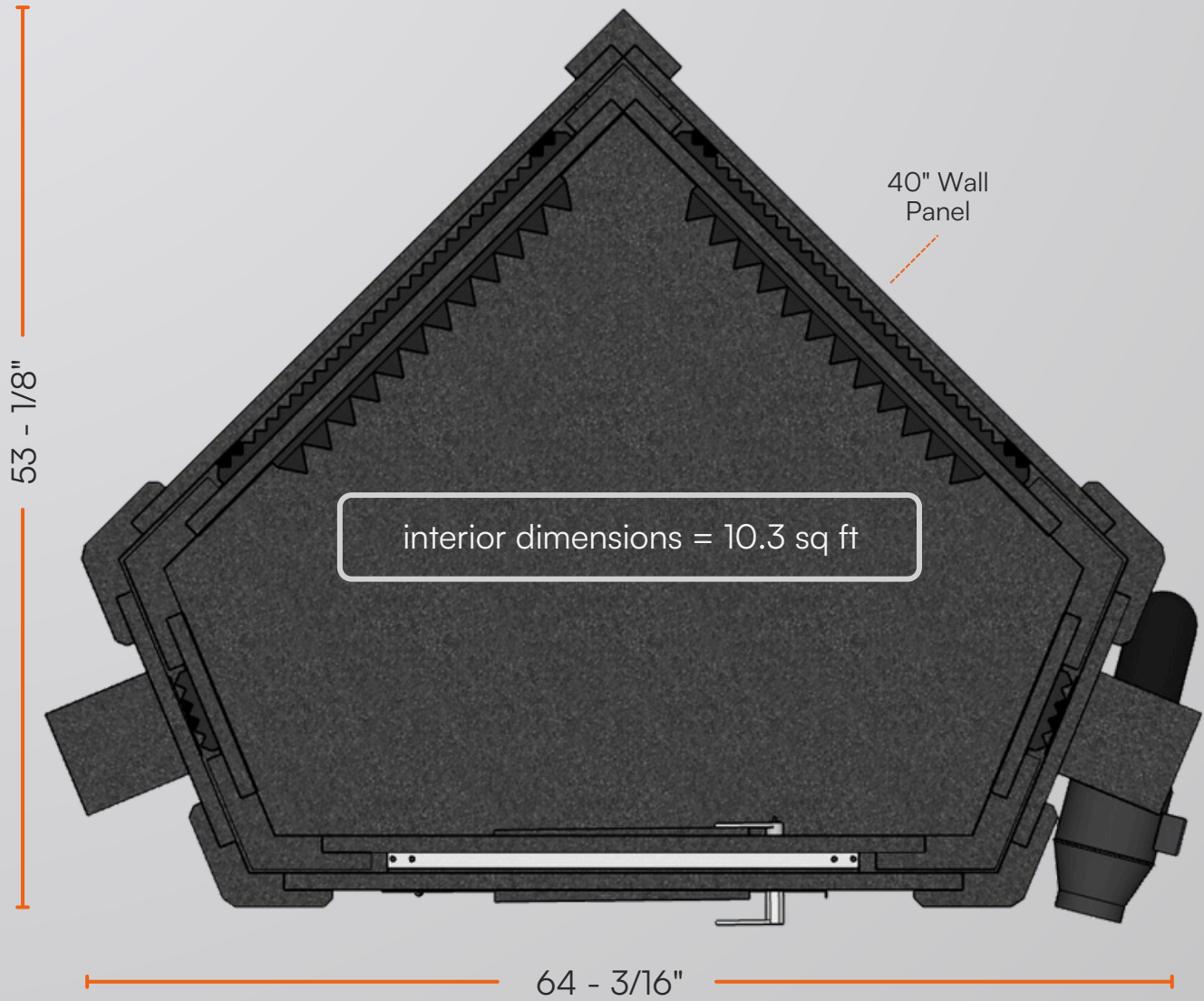

## All 40" wall components are interchangeable:

- Solid Wall Panels
- Wall with Door

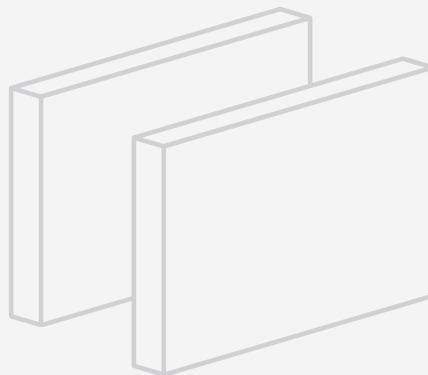

## Ventilation & Clearance:

- Vent system protrudes 5.5"
- Allow 6" from host room walls
- Door swing: 24", opens outward

# MDL 127 LP E

Double-Wall Sound Booth | 10.3 sq ft

## Basic Features (Included)



Ventilation system



12" x 30" door window



Cable passages (4)

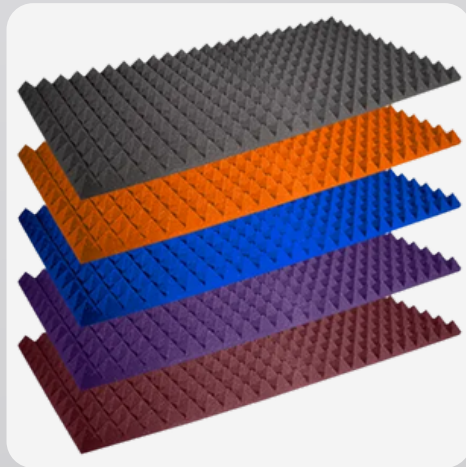

Acoustic studiofoam (2)



18" LED light



Remote switch

## Options & Accessories (Sold Separately)

### Interior Upgrades

- Studio light
- Audimute acoustic panels
  - Acoustic package
  - LENRD bass traps

### Structural Mods

- 10" height extension

### Ventilation Upgrades

- HEPA filter
- Ventilation silencing system
- Exterior fan silencer

### Access & Mobility

- Caster plate
- Step

### Functional Add-Ons

- Multi jack panel