

MDL 6060 E

Double-Wall Sound Booth | 5' x 5'



Shown with
optional
studio light

WhisperRoom®

MDL 6060 E

Double-Wall Sound Booth | 5' x 5'

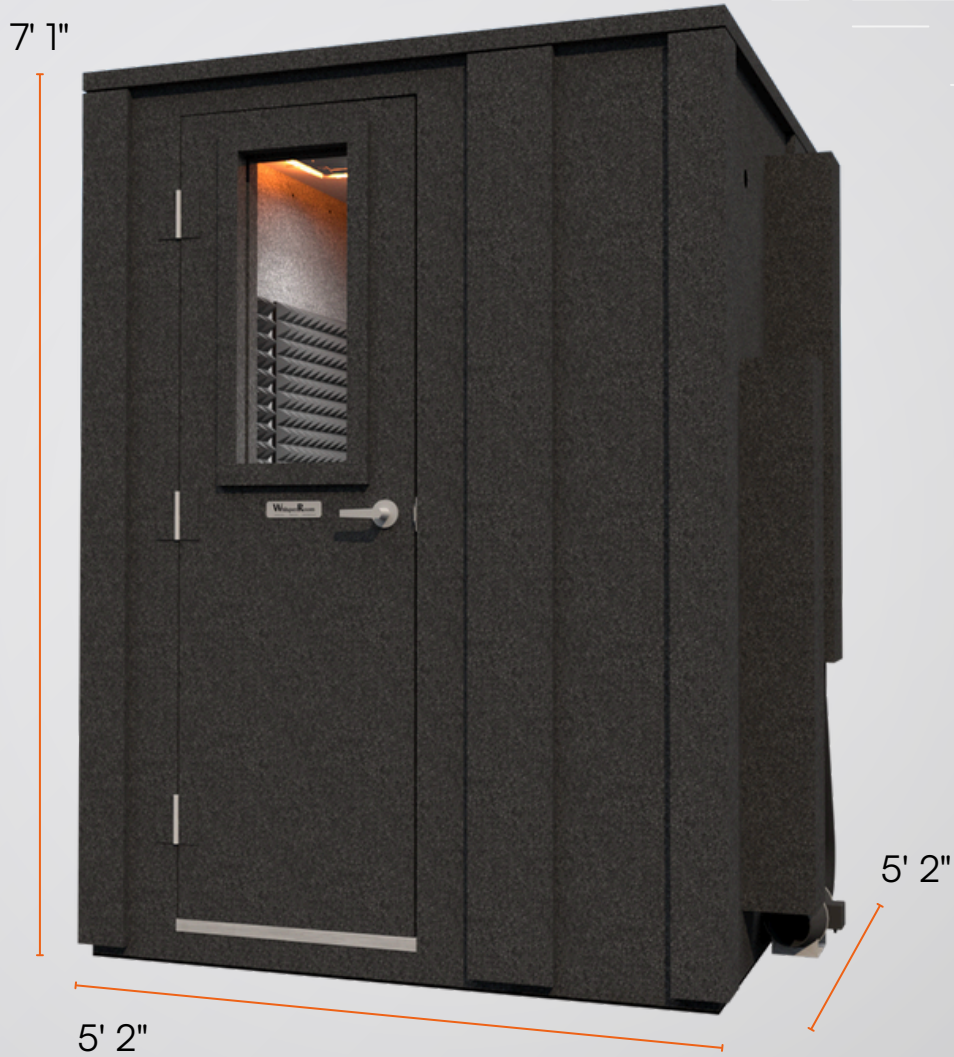

Exterior Dimensions	5' 2" x 5' 2" x 7' 1"
Interior Dimensions	4' 5.5" x 4' 5.5" x 6' 8"
Assembled Weight	1555 lbs (705 kg)
Assembly Time	~ 5 hours
Wall Thickness	1" MDF barrier + 1.25" air gap + 1" MDF barrier
Wall Panel Layers	Two 1" MDF barrier + 1.25" air gap + 2" foam
Door Window Thickness	3 1/8"
Door Window Layers	Dual laminated glass sets with central air gap
Window Size	12" x 30"

Note: Exterior dimensions exclude 5.5" ventilation duct protrusion. Height increases by 5" with the optional caster plate.

MDL 6060 E

Double-Wall Sound Booth | 5' x 5'

Top-Down Layout & Modular Panel Configuration

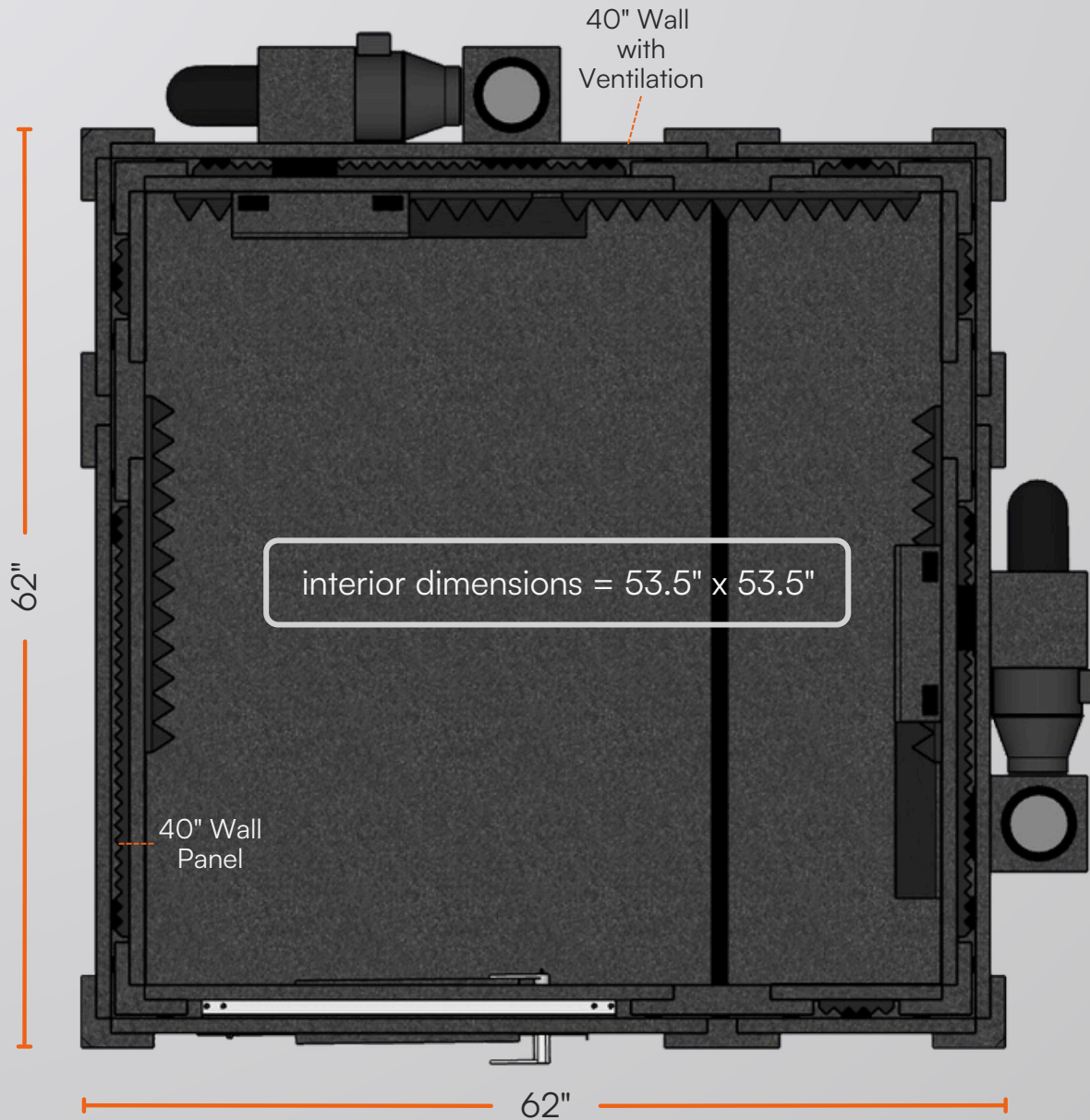

All 40" wall components are interchangeable:

- Solid Wall Panels
- Wall with Ventilation
- Wall with Door
- Wall with Window (optional)

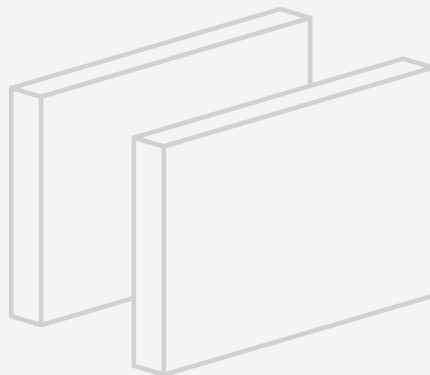

Ventilation & Clearance:

- Vent system protrudes 5.5"
- Allow 6" from host room walls
- Door swing: 24", opens outward

MDL 6060 E

Double-Wall Sound Booth | 5' x 5'

Basic Features (Included)



Ventilation systems (2)



12" x 30" door window



Cable passages (4)

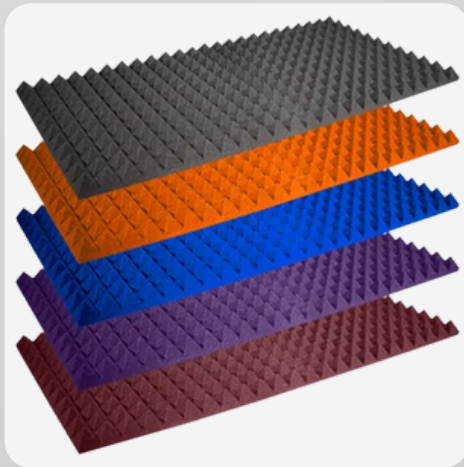

Acoustic studiofoam (4)



18" LED light



Remote switch

Options & Accessories (Sold Separately)

Interior Upgrades

- Studio light
- Audimute acoustic panels
 - Acoustic package
 - LENRD bass traps

Structural Mods

- 10" height extension
- Wall windows

Ventilation Upgrades

- HEPA filter
- Ventilation silencing system
- Exterior fan silencer

Access & Mobility

- Caster plate
- Step
- Wide access door

Functional Add-Ons

- Multi jack panel
- Office desk