

# MDL 96120 E

Double-Wall Sound Booth | 8' x 10'



Shown with optional  
studio light and  
wall window

**WhisperRoom**®

# MDL 96120 E

Double-Wall Sound Booth | 8' x 10'



Exterior Dimensions	8' 2" x 10' 2" x 7' 1"
Interior Dimensions	7' 5.5" x 9' 5.5" x 6' 8"
Assembled Weight	3100 lbs (1406 kg)
Assembly Time	~ 7 hours
Wall Thickness	1" MDF barrier + 1.25" air gap + 1" MDF barrier
Wall Panel Layers	Two 1" MDF barrier + 1.25" air gap + 2" foam
Door Window Thickness	3 1/8"
Door Window Layers	Dual laminated glass sets with central air gap
Window Size	16" x 30"

**Note:** Exterior dimensions exclude 5.5" ventilation duct protrusion. Height increases by 5" with the optional caster plate.

# MDL 96120 E

Double-Wall Sound Booth | 8' x 10'

Top-Down Layout & Modular Panel Configuration

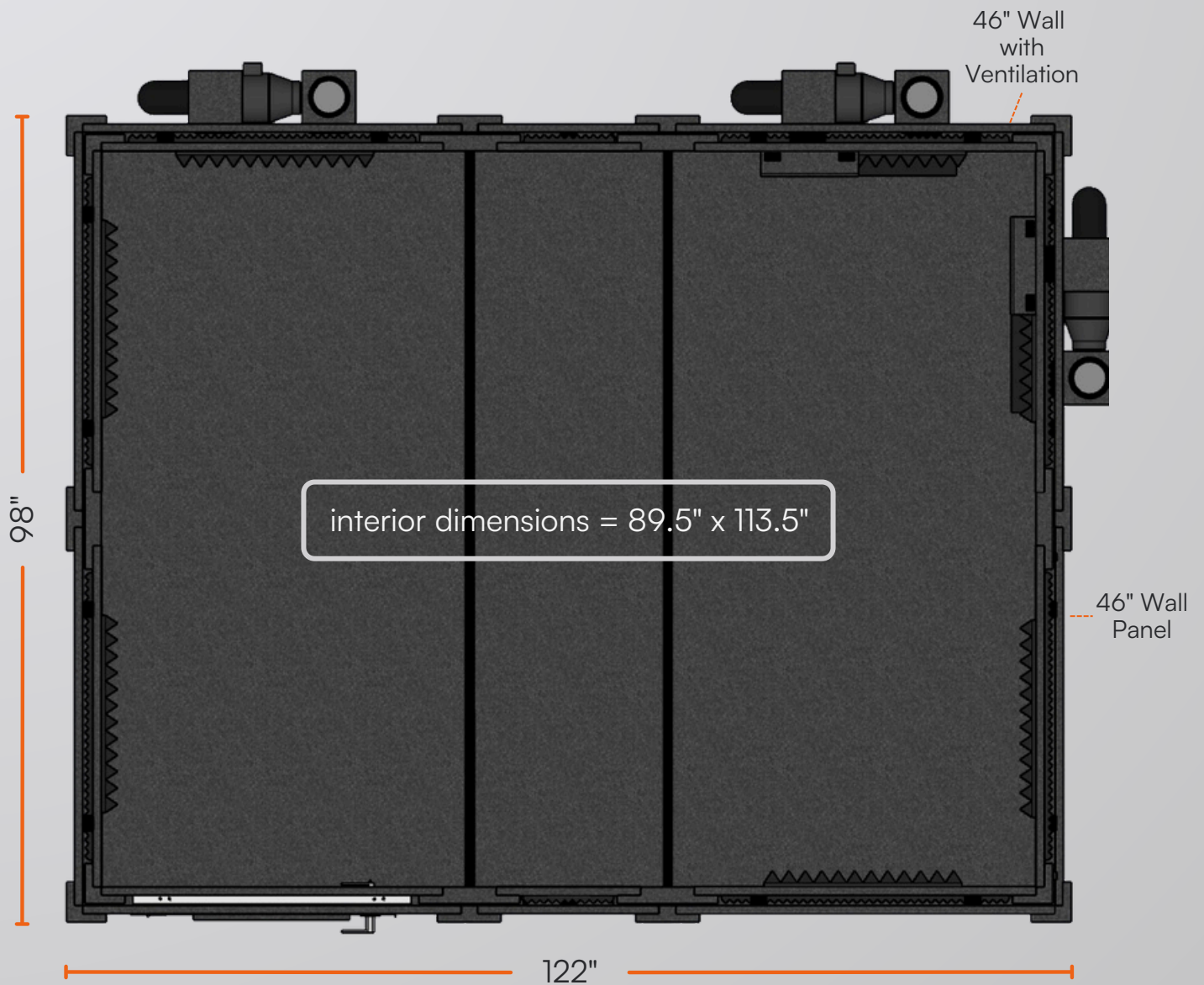

## All 46" wall components are interchangeable:

- Solid Wall Panels
- Wall with Ventilation
- Wall with Door
- Wall with Window (optional)

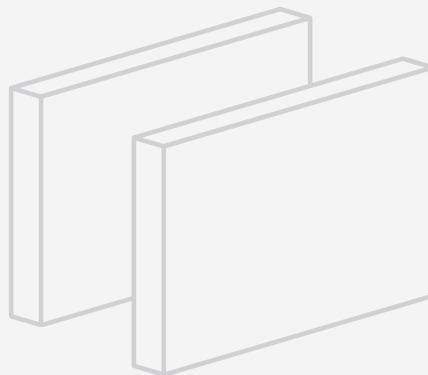

## Ventilation & Clearance:

- Vent system protrudes 5.5"
- Allow 6" from host room walls
- Door swing: 30", opens outward

# MDL 96120 E

Double-Wall Sound Booth | 8' x 10'

## Basic Features (Included)



Ventilation systems (3)



16" x 30" door window



Cable passages (6)



Acoustic studiofoam (7)



18" LED light



Remote switch

## Options & Accessories (Sold Separately)

### Interior Upgrades

- Studio light
- Audimute acoustic panels
  - Acoustic package
  - LENRD bass traps

### Structural Mods

- 10" height extension
- Wall windows

### Ventilation Upgrades

- HEPA filter
- Ventilation silencing system
- Exterior fan silencer

### Access & Mobility

- Caster plate
- Step
- Wide access door
- ADA package

### Functional Add-Ons

- Multi jack panel
- Office desk