

MDL 102102 E

Double-Wall Sound Booth | 8.5' x 8.5'



Shown with optional
studio light and
wall window

WhisperRoom®

MDL 102102 E

Double-Wall Sound Booth | 8.5' x 8.5'



Exterior Dimensions	8' 8" x 8' 8" x 7' 1"
Interior Dimensions	7' 11.5" x 7' 11.5" x 6' 8"
Assembled Weight	2985 lbs (1354 kg)
Assembly Time	~ 9 hours
Wall Thickness	1" MDF barrier + 1.25" air gap + 1" MDF barrier
Wall Panel Layers	Two 1" MDF barrier + 1.25" air gap + 2" foam
Door Window Thickness	3 1/8"
Door Window Layers	Dual laminated glass sets with central air gap
Window Size	12" x 30"

Note: Exterior dimensions exclude 5.5" ventilation duct protrusion. Height increases by 5" with the optional caster plate.

MDL 102102 E

Double-Wall Sound Booth | 8.5' x 8.5'

Top-Down Layout & Modular Panel Configuration

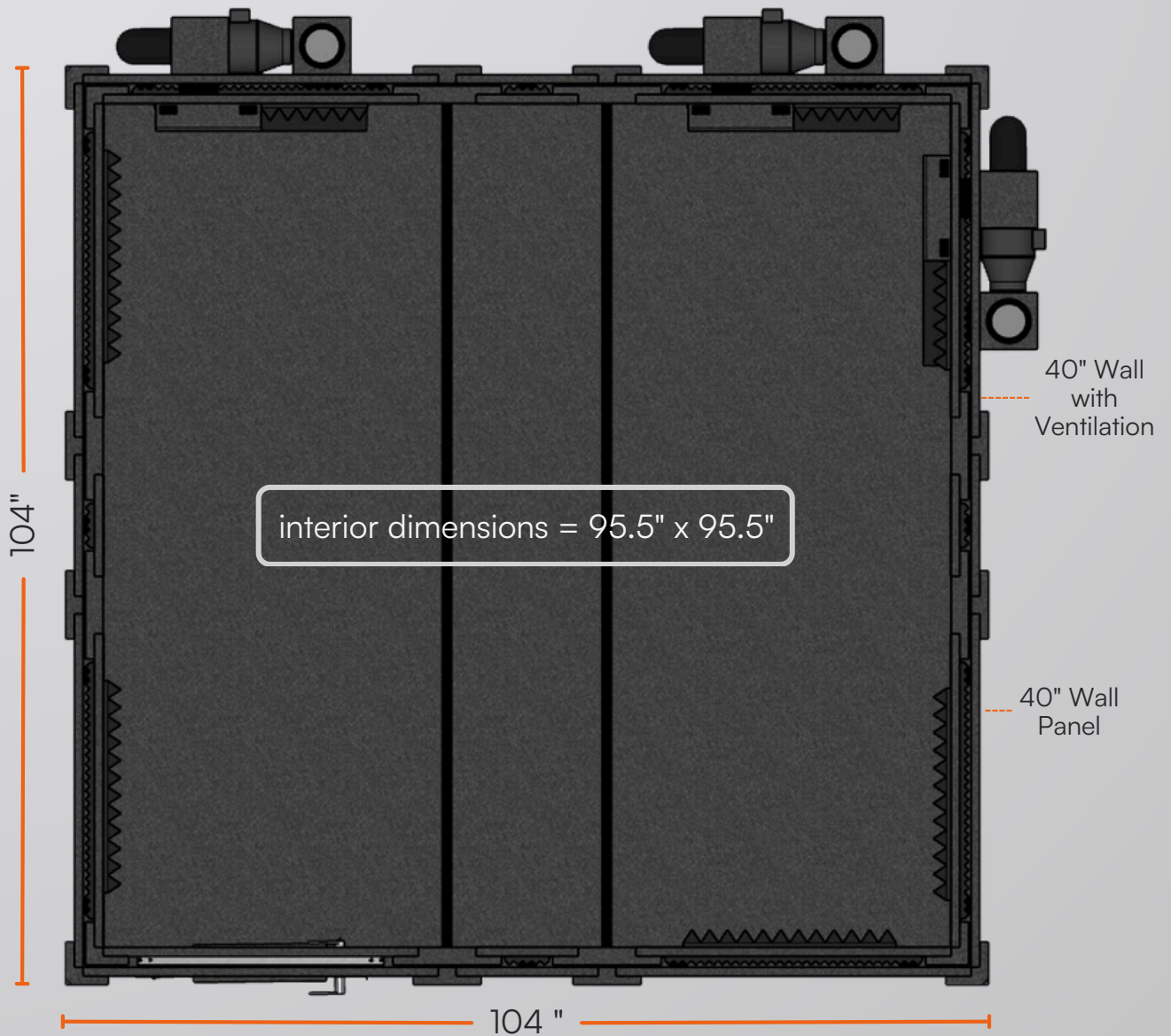

All 40" wall components are interchangeable:

- Solid Wall Panels
- Wall with Ventilation
- Wall with Door
- Wall with Window (optional)

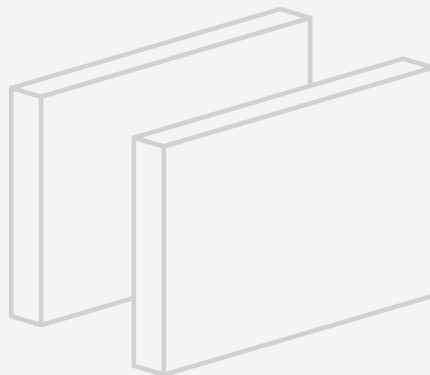

Ventilation & Clearance:

- Vent system protrudes 5.5"
- Allow 6" from host room walls
- Door swing: 24", opens outward

MDL 102102 E

Double-Wall Sound Booth | 8.5' x 8.5'

Basic Features (Included)



Ventilation systems (3)



12" x 30" door window



Cable passages (6)

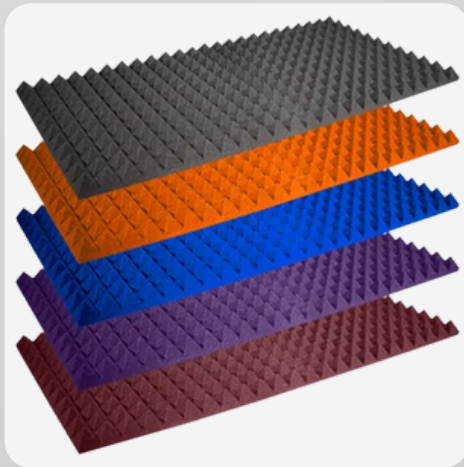

Acoustic studiofoam (7)



18" LED light



Remote switch

Options & Accessories (Sold Separately)

Interior Upgrades

- Studio light
- Audimute acoustic panels
 - Acoustic package
 - LENRD bass traps

Structural Mods

- 10" height extension
- Wall windows

Ventilation Upgrades

- HEPA filter
- Ventilation silencing system
- Exterior fan silencer

Access & Mobility

- Caster plate
- Step
- Wide access door

Functional Add-Ons

- Multi jack panel
- Office desk