

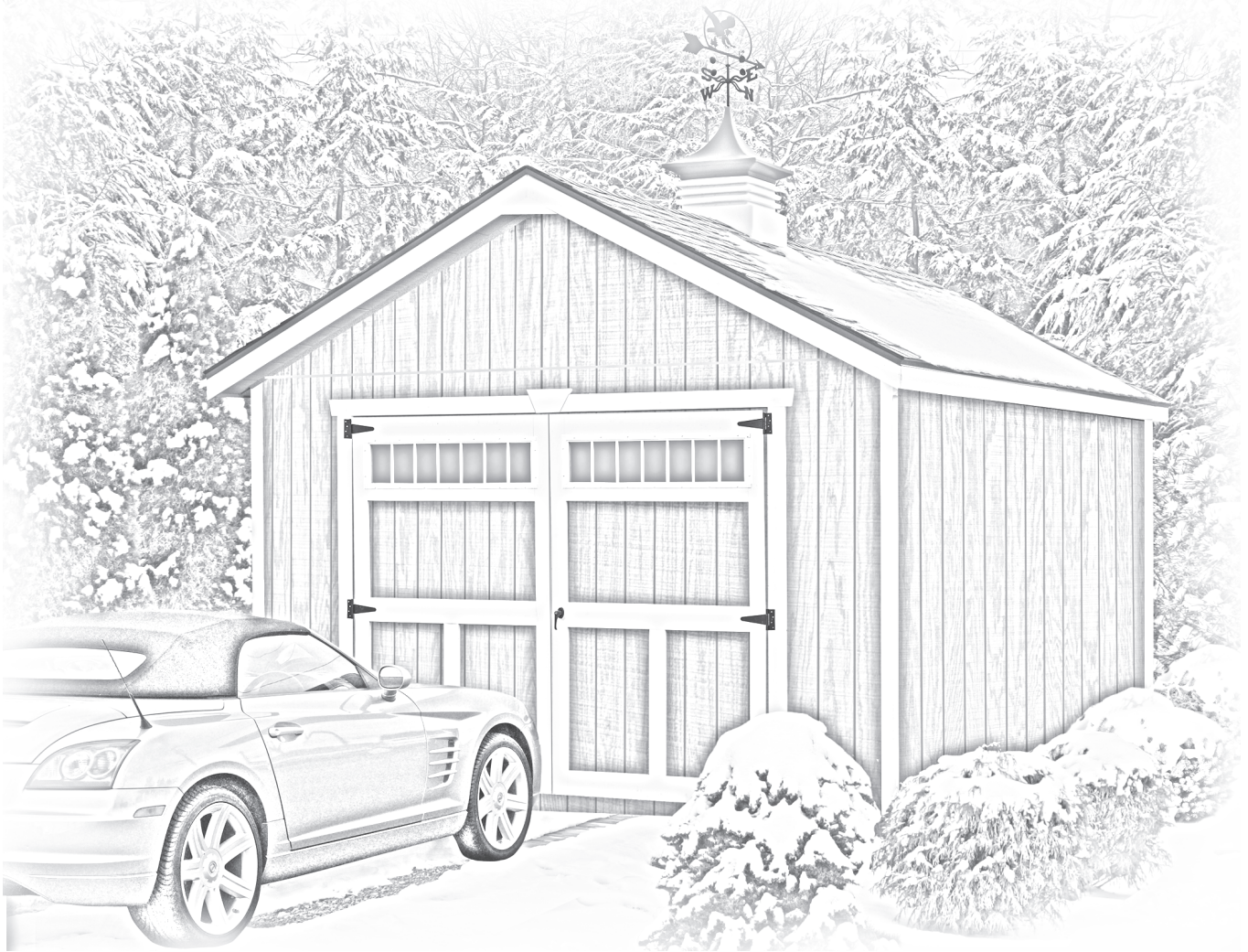

Assembly Book

Revised February 5, 2026



Tailored Titan Transom Door 12'x24'

Manufactured by RBS Holdings, LLC
205 Arlington Drive Greenville, PA 16125

This manual is copyrighted. Under the copyright laws, this manual may not be copied, in whole or in part, without consent from RBS Holdings, LLC © Copyright 2022

IMPORTANT INFORMATION ABOUT YOUR KIT

Thank you for purchasing our kit. Please read the following information before beginning construction. Always check with your local HOA or building code office for any requirements or restrictions.

Floor: Wood flooring is sold optionally. You may choose to build your own or pour a cement pad.

Always wear safety glasses when cutting or nailing!

Tools Required:	Hand or Circular Saw	Level	Safety Glasses
	Cordless Drill	Measuring Tape	Dust Mask
	Hammer	6'-8' Ladder(s)	Screwdriver with Bits
	Pencil		Framing Square

Additional Materials - **Not included in kit:**

Windows are purchased separately

Required: Shingles or metal roofing, Drip Edge, Roofing Nails or Screws, Paint, Class 25 Sealant

Optional: Caulk, Ridge Vent

Terminology:

Square - Confirm corners are at 90 degrees

Plumb - Confirm walls and trusses are straight vertically

Wall Plate - Top and bottom 2x4s used to frame walls

Tie Plate - 2x4s connecting wall sections together

Header - Spans top of door opening

OSB - Oriented Strand Board

LAP - Edge of siding that overlaps

Tongue - Edge of siding that is overlapped

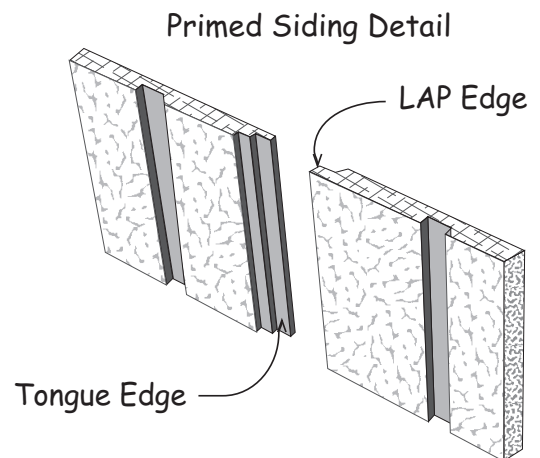

Organize:

Unpack all items & organize according to size and type. This will make items easier to find when instructed.

Review the parts list on the back page. Should there be missing items or sub-par material contact Best Barns Customer Service.

DO NOT discard any material including the pallet until your project is complete.

Assembly:

Review all instructions before you begin. Please follow steps carefully and in sequence for successful results.

If you have any questions we are happy to assist you. Please contact us at:

800-245-1577 - Mon - Fri 8AM - 5PM EST

724-866-4357 - After hours and weekends

Email - help@barnkits.com

Optional Wood Floor System

Shown below is a typical wood floor. Depending on your area, the construction may have to be changed to meet local codes. The foundation size should be 12' - 0" x 24' - 0".

1. Cut (2) two treated 2x4-8' boards in half.
2. Butt 4x4-12' treated runners together. Use one of the 4' long 2x4s to secure them together. Note: Use 16d galv. nails to secure all treated framing together.
3. Repeat to join the other 4x4 runners.

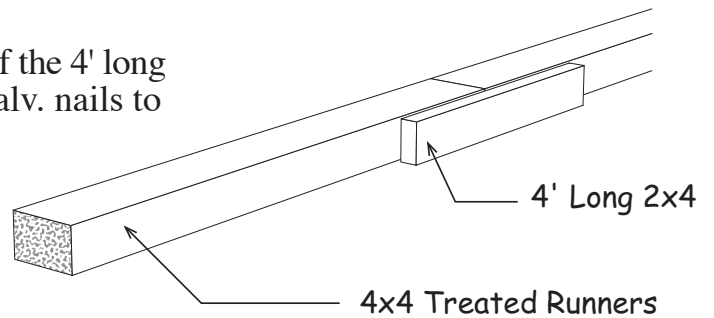

4. Cut (2) two 2x4-12' joist headers to 12' - 0".
5. Layout for 12" on center joist spacing. 'X' marks where floor joist will be placed.

Detail 1

2x4 - 12' 0"
Joist Header

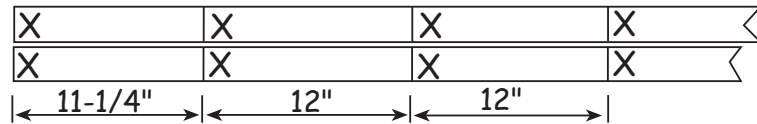

6. Cut all the 2x4-12' boards to 11'-9". These boards will be the floor joist. *Treated lumber may be thicker than 1-1/2". Take this into account when cutting the length of floor joists. Shorten joist measurements if necessary to obtain 12'-0" building width.*
7. Install floor joist boards between the joist headers. Use 16d galv. nails. Install this section over 4x4s.

2x4-12' Joist Header

2x4-11' 9" Floor Joist

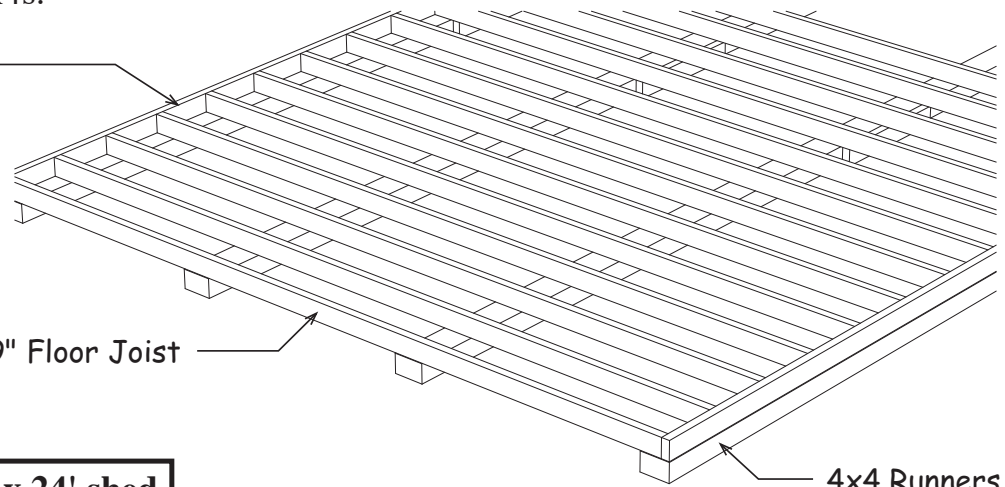

Material Description	12' x 24' shed
2x4 Treated	2 pcs. 8'
2x4 Treated	30 pcs. 12'
4x4 Treated Runners	8 pcs. 12'
Flooring 3/4"	9 pcs. 4x8
Screw Floor Nails	5 lb. 8d
Galv. Box Nails	5 lb. 16d

Optional Wood Floor System

8. Assemble another floor section. Install over the 4x4s and nail both floor sections together.

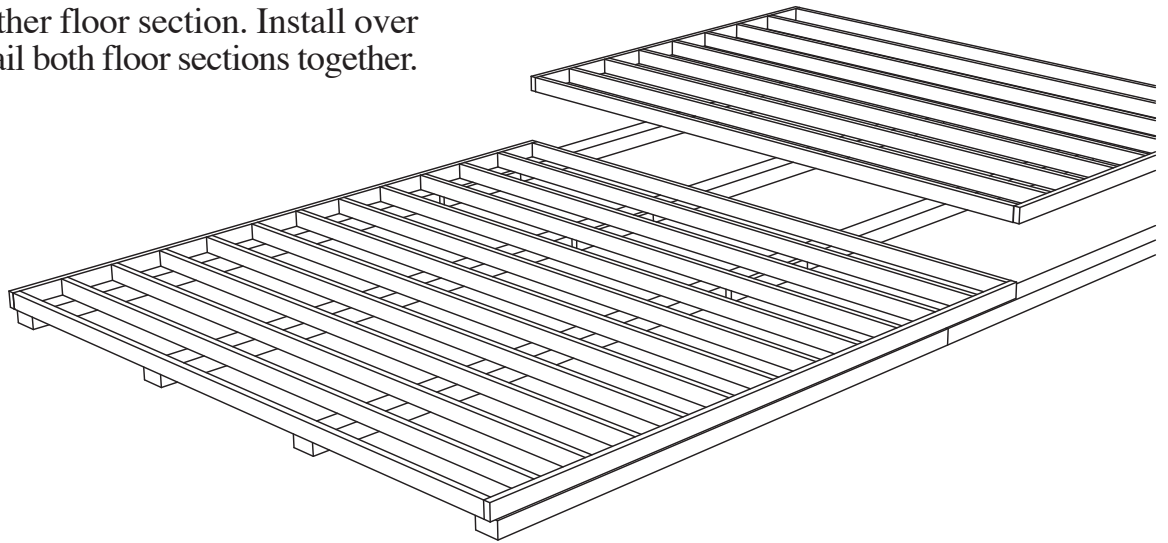

9. Square the floor. See note below. The angle measurement should be 26' - 10". Nail several floor joist to the 4x4 runners to hold the floor frame in place.

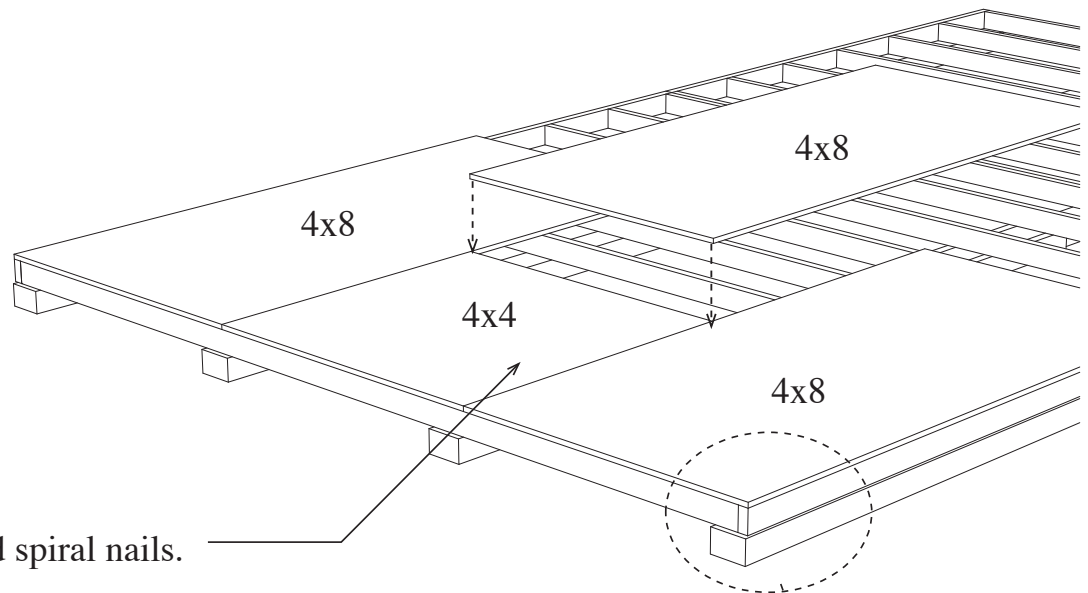

10. Install floor using 8d spiral nails.

Notes To Floor

It is important that the floor be level and square. Square the floor as follows: before nailing the flooring, measure the floor diagonally (corner to corner). Then measure the opposite corners. These measurements will be the same if the floor is square.

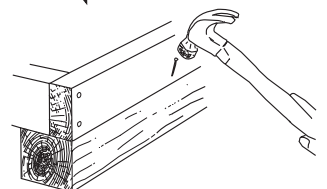

Step 1 Assemble Side Walls

 *Do not discard any material until construction is complete, including short 2x4 blocks.*

1. Cut (2) two 2x4-12' to a length of 140-1/2". Position the boards together and indicate with 'X' marks where the wall studs will be located.

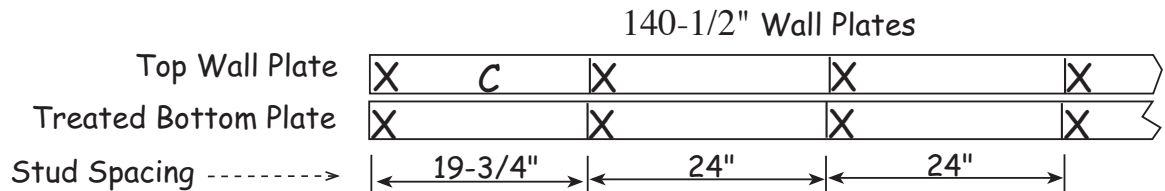

2. Mark a 'C' anywhere left of first stud mark. This is referenced in a later step.
3. Install (7) seven pre-cut wall studs between the top & bottom plates. Nail top plate to studs using (2) two 10d sinkers per stud. Nail bottom plate to studs using (2) two 16d galv. nails per stud.

 *The length of pre-cut studs will vary from 92-1/4" to 93" depending on you locality.*

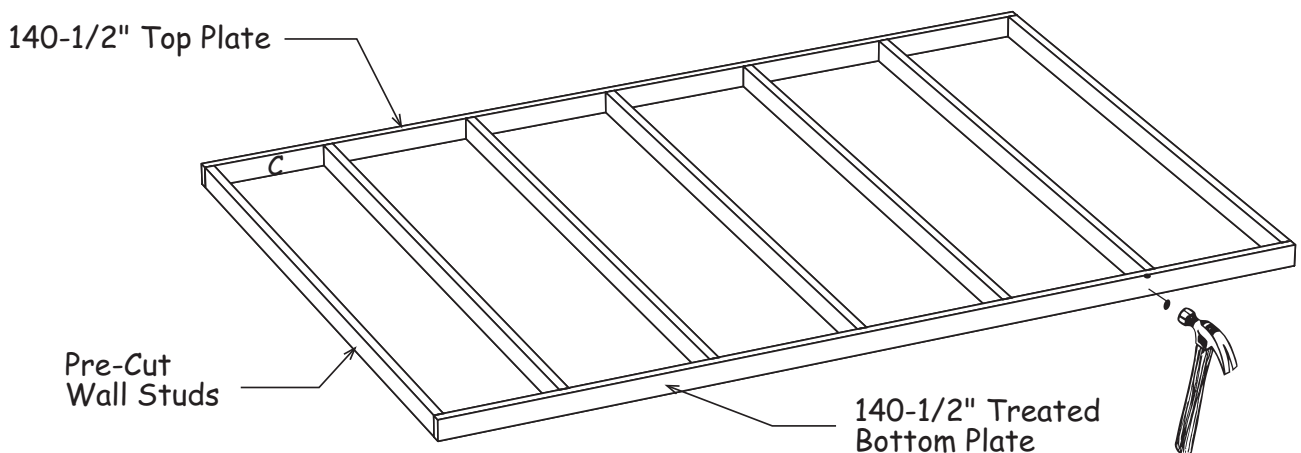

4. Repeat to assemble (3) three more 140-1/2" long wall frames.
5. Set frames aside.

Step 2 Assemble Door Header

1. Locate (2) two 2x8-10' boards. Cut these boards to a length of 99".
2. Assemble the door header using 2x8 boards and (2) two 7-1/4" x 48" OSB filler included in our kit. Position OSB fillers 1-1/2" from either end of 2x8s. Nail together with (12) twelve 10d sinkers spaced evenly on each side.

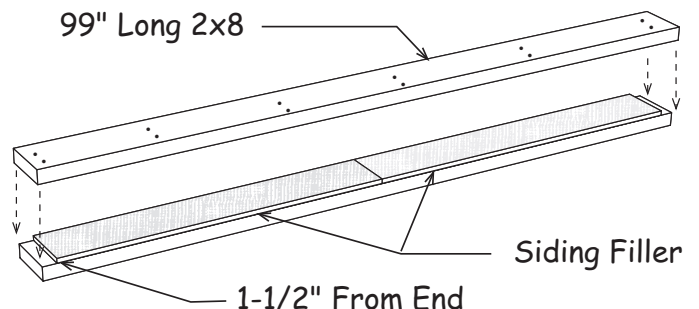

Step 3 Assemble 12' Back Wall

1. Cut (2) two 2x4-12' (one will be treated) to a length of 144". Position the boards together and indicate with 'X' marks where the wall studs will be located.

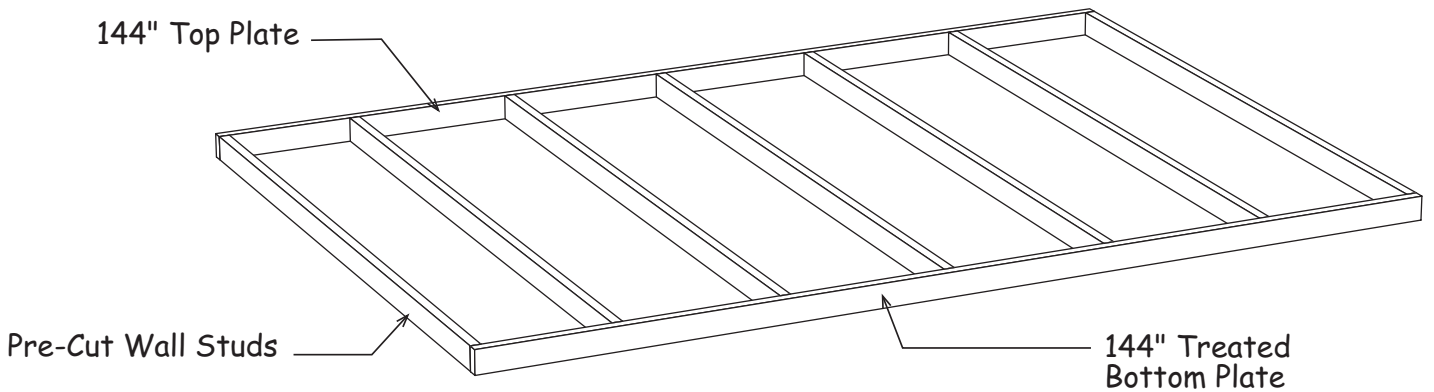
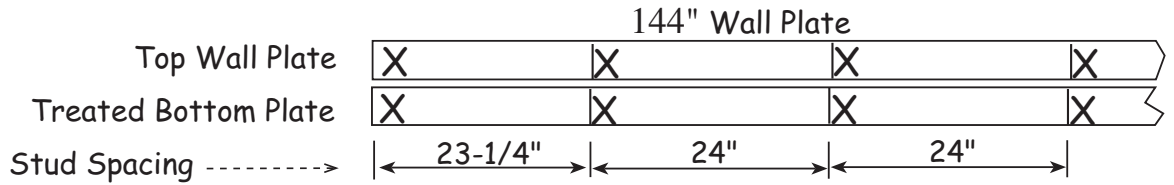

2. Install (7) seven pre-cut wall studs between the top & bottom plates. Nail top plate to studs using 10d sinkers. Nail bottom plate to studs using 16d galv. nails.
3. Square wall frame. Measure the wall diagonally (corner to corner). Then measure the opposite corners. These measurements will be the same if the wall is square.
4. Install the first siding panel with the 'LAP' edge flush with the side of the wall stud and flush with the top 2x4 plate. Nail siding with 6d galv. nails, spaced 8" apart. Cut the siding flush with the 2x4 bottom plate if you are installing the building on a concrete slab.
5. Install (2) two more siding panels. Cut the last panel flush with the end of the frame.

 Depending on length of pre-cut studs siding may extend below bottom plate.

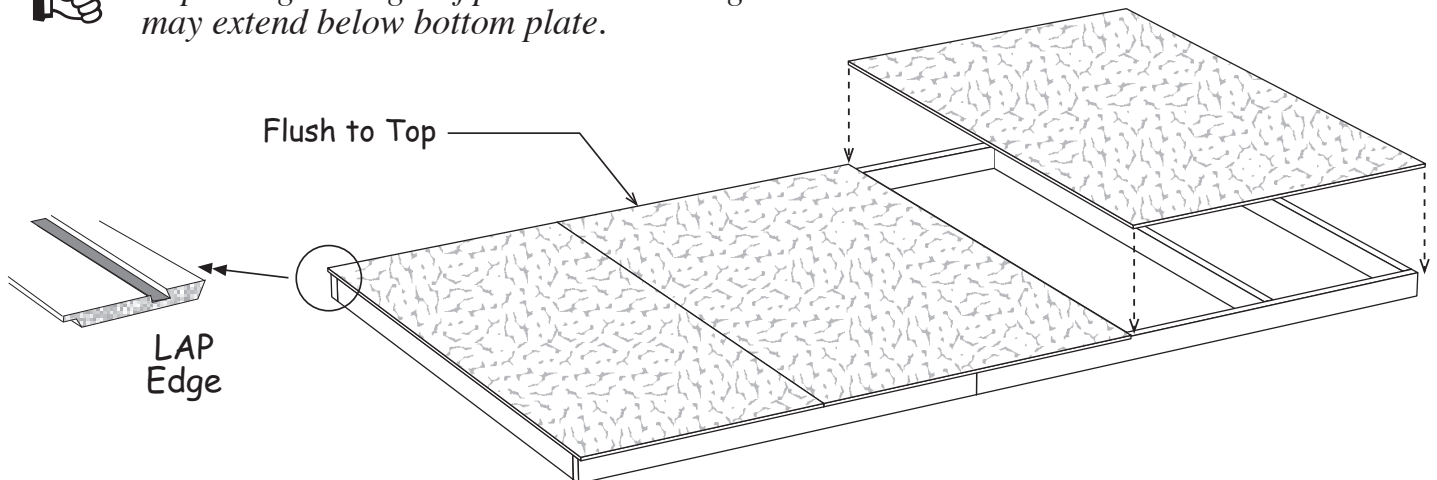

Step 4 Assemble Front Wall Frame

1. Cut (2) two 2x4-12' boards (one will be treated) to a length of 144" for wall plates. Position the boards together and indicate with 'X' Marks where the wall studs will be located.

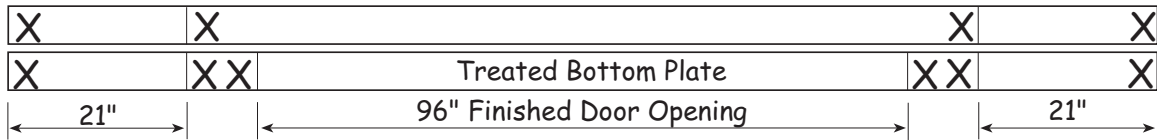

2. Install (4) four pre-cut wall studs between the wall plates where shown. Nail top plate to studs using 10d sinkers. Nail bottom plate to studs using 16d galv. nails.

3. Cut (2) pre-cut studs to a length of 82" and install as header supports where shown. Nail to stud using 10d sinkers.

4. Install the door header on the header supports. Nail to the wall stud with 10d sinkers.

5. Measure space between header and top plate. Cut from a pre-cut stud (5) five pieces to this length. Evenly space pieces and nail through top plate and toenail to header. Use 10d sinkers.

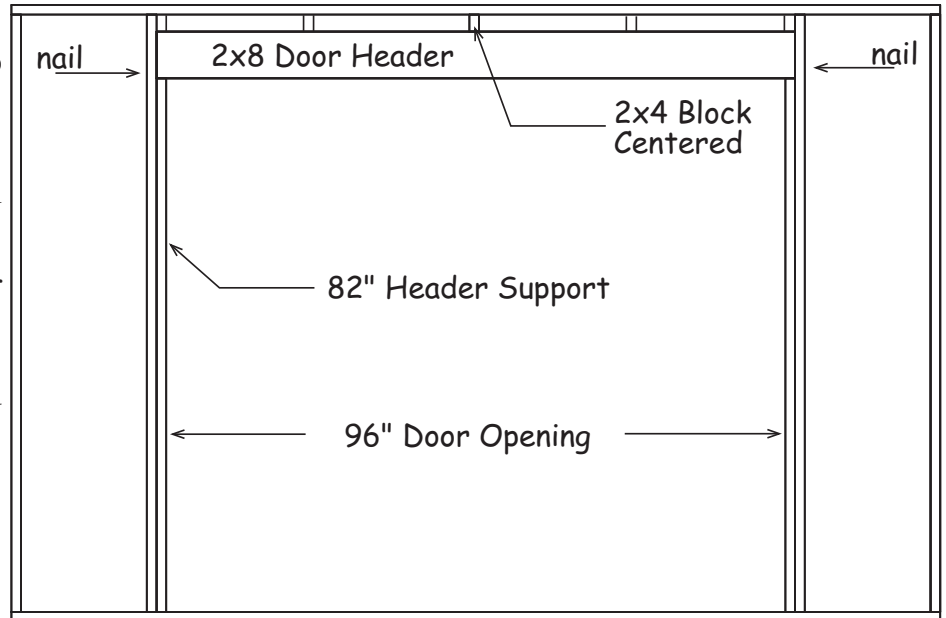

6. Cut a siding panel in half length-ways. Select the panel with the 'Tongue' Edge. Save the other panel for step 9 below.

7. Install panel with the 'Tongue' edge flush with door opening and cut edge flush with end of wall. Top of siding should be flush with top plate. Use 6d galv. nails.

8. Install (2) two 20"x48" siding panels above the door opening flush with top of plate. Cut siding 3/4" below the bottom of the 2x8.

9. Install remaining panel with LAP edge flush with door opening.

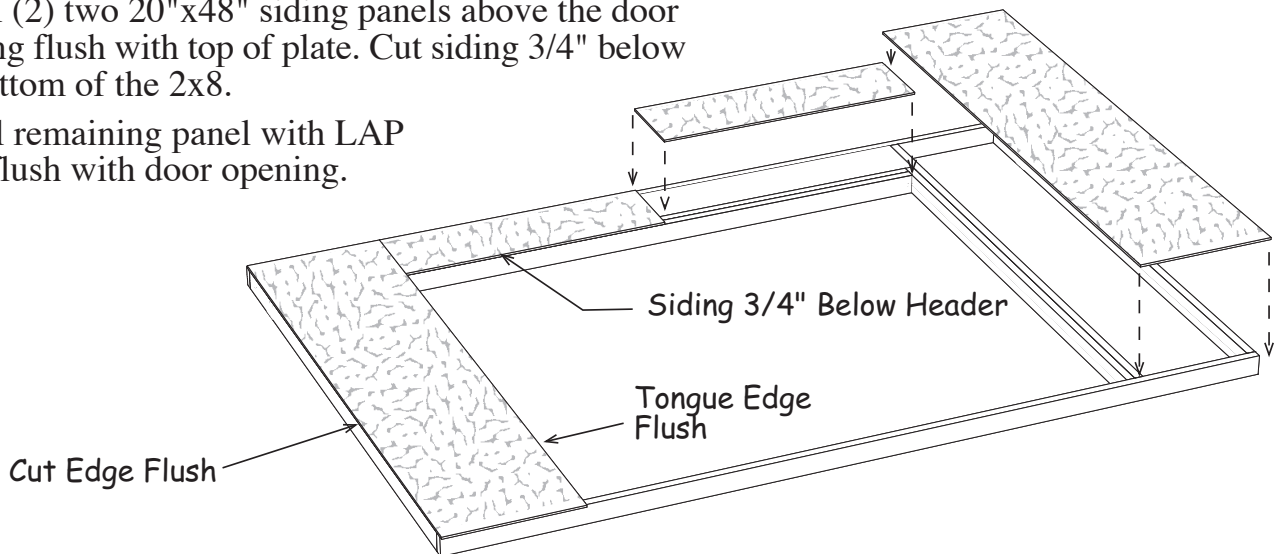

Step 5 Set Wall Panels

1. Erect back wall and side walls. **IMPORTANT:** Install the side walls with the 'C' marks oriented against the back and front wall panels. Secure walls together at the corners. Use (4) four 10d sinkers per corner. Brace side walls with pre-cut wall studs to hold walls secure and plumb.
2. Cut a siding panel in half lengthways. Select the panel with the 'tongue' edge. Install this panel at the back corner with the cut edge flush with the siding on the back wall and flush with top plate. Nail siding to back wall and all 2x4s using 6d galv. nails spaced 8" apart
3. Install (5) five more siding panels. Install 24" wide siding to finish. Siding should extend no more than 3-1/2" past wall to receive front wall panel.
4. Start at back wall and apply siding to opposite wall.
5. Erect front wall panel and secure corners with 10d sinkers. Nail siding to front wall.
6. Cut and remove bottom 2x4 from door opening.
7. Nail walls to floor through bottom plate. Space 16d galv. nails 24" apart.

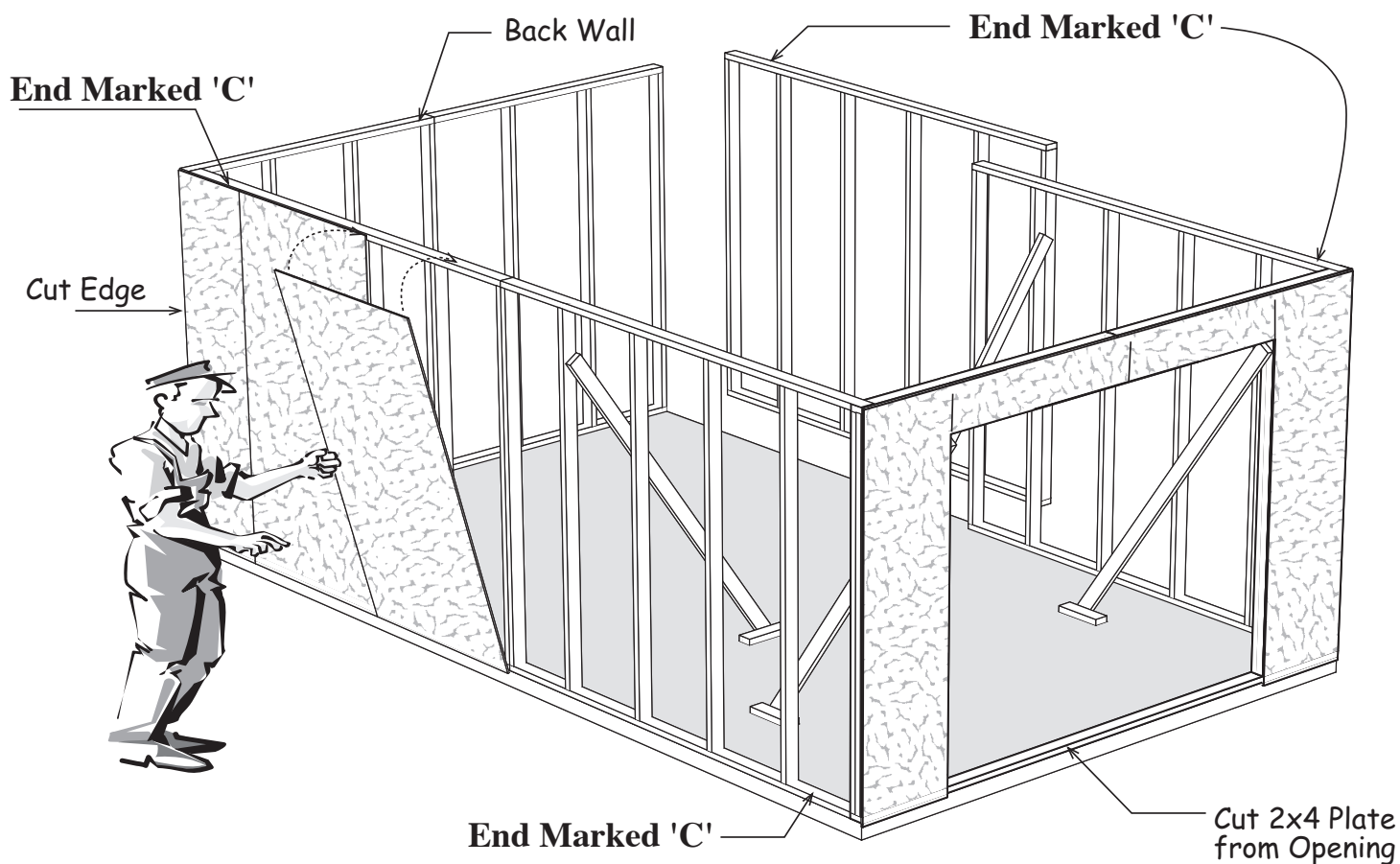

Step 6 Assemble Roof Gables

1. Cut (2) two 2x4-12' boards to a length of 144".
2. Place one of the 144" boards on the floor along with (2) two 80-1/2" long 2x4 rafters as shown below. Bottom 144" plate will be on edge. Rafters will lay flat.



There are short 2x4s, *that may have an angle on one end*, supplied in the kit. Use these to hold the rafters and bottom gable plate together by temporarily screwing the blocks to the floor using 2-1/2" screws. This will ensure that the gable frames and the trusses are identical.

3. Secure the top of the rafters together with a 1"x4" barbed metal drive-on plate.
4. Install (2) two 23-1/2" gable studs with angle cut at one end. Nail through the bottom plate with 10d sinkers and secure the top with barbed metal drive-on plates.

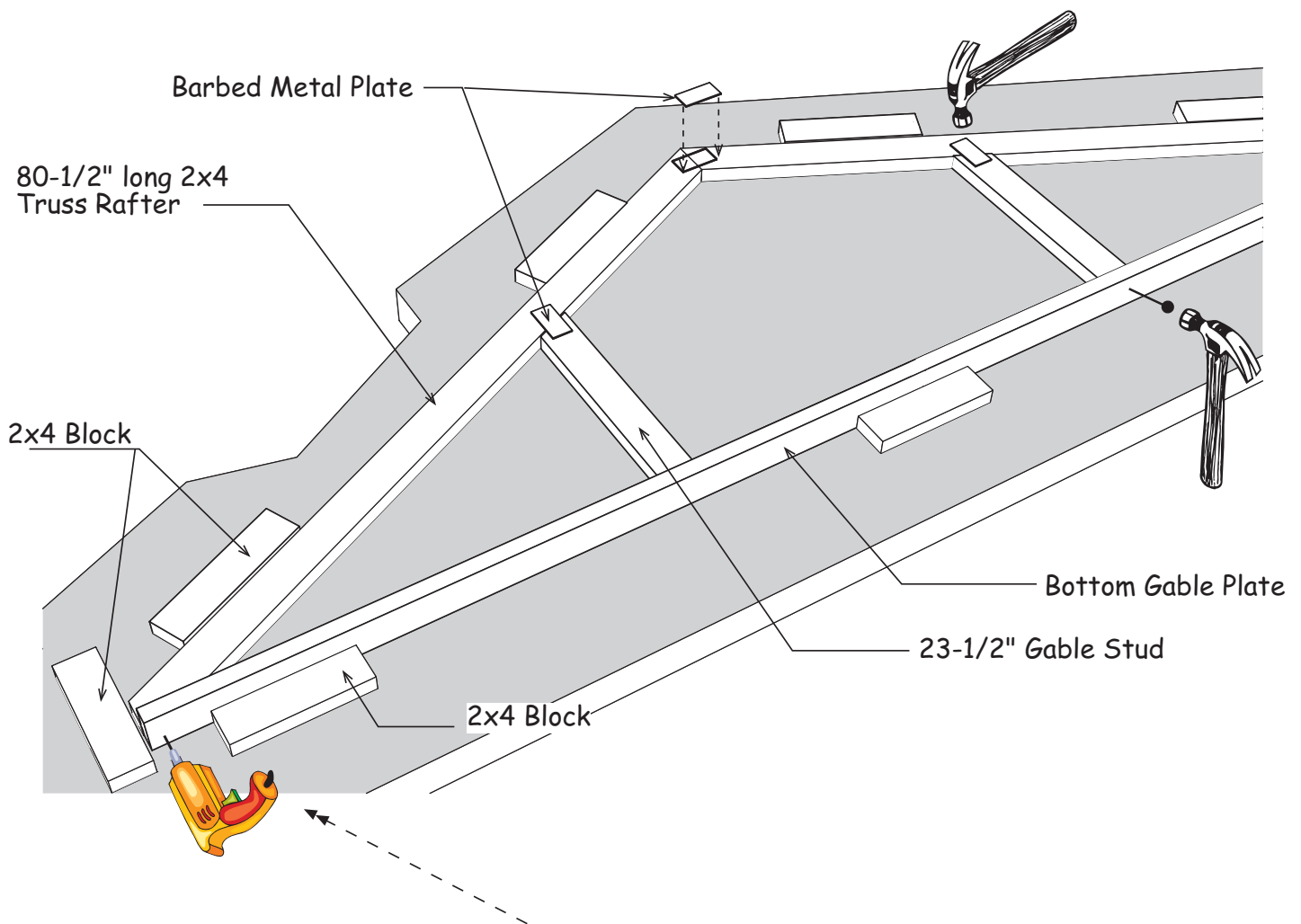

5. Secure the 2x4 bottom plate to the truss rafter with a 2-1/2" wood screw on both ends. Set gable aside.
6. Repeat steps to assemble another gable.

Step 7 Assemble Roof Trusses

1. Place (2) two 80-1/2" long 2x4 truss rafters and a 82" long collar tie together as shown below. The collar tie has an angle cut on both ends. Reposition the lower 2x4 blocks to hold the truss rafters in place. See 'Detail B'.
2. Secure the 2x4 truss rafters at the top with a 8" x 16" wood gusset. Nail the gusset to the 2x4s with (14) fourteen 6d common nails,
3. Secure the 2x4 collar tie with (4) four 2-1/2" long wood screws at each end. Tip: Pre-drill holes with an 1/8" bit to prevent wood splitting at ends.
4. Turn this truss over and apply a wood gusset to the opposite side at the ridge.
5. Repeat to assemble (10) ten more trusses.

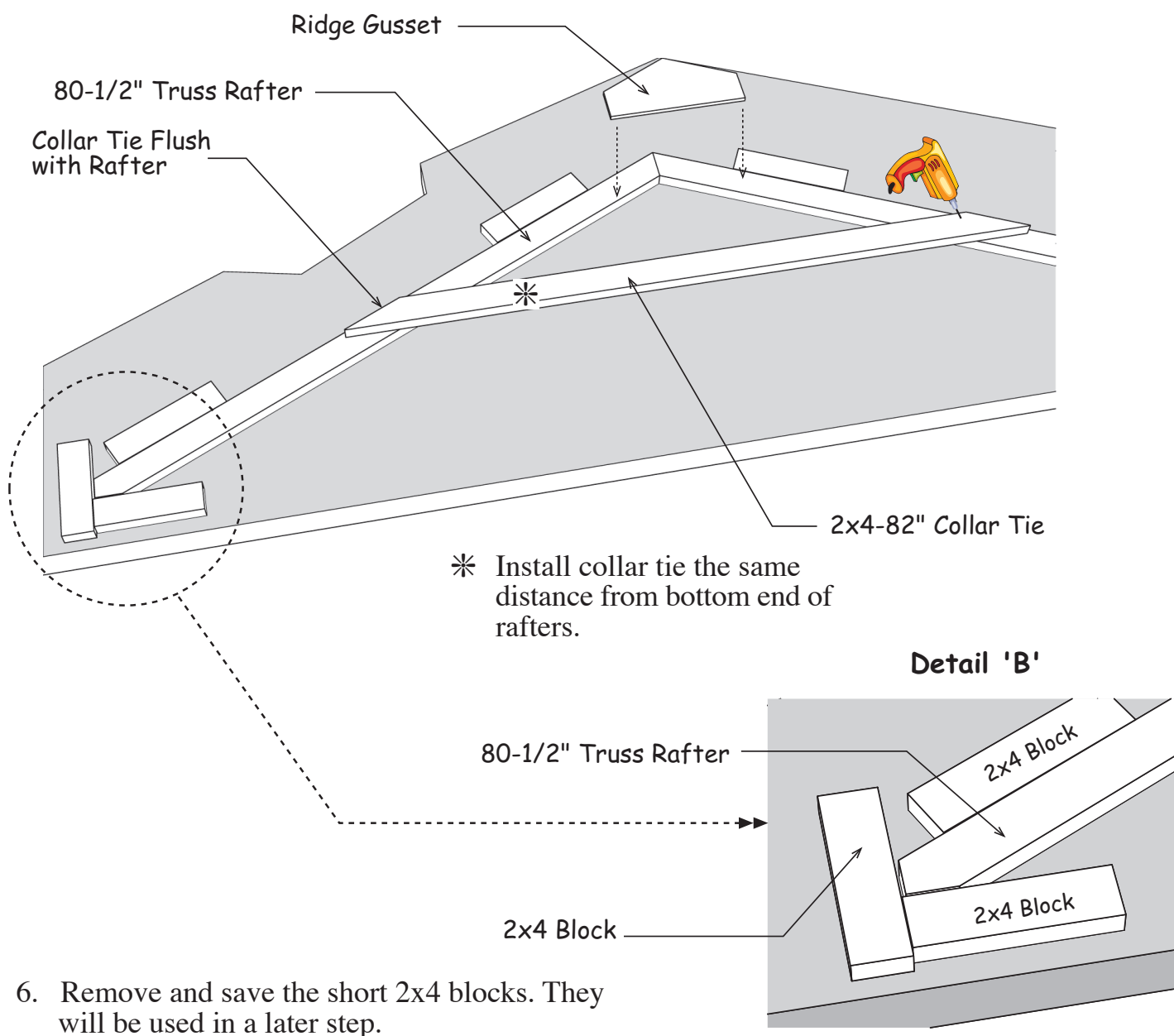

6. Remove and save the short 2x4 blocks. They will be used in a later step.

Step 8 Install Primed Soffit and Fillers

1. Install a 7" wide x 48-3/4" siding panel over the side wall with the primed side facing down. The 'tongue' edge should be flush with front wall plate, NOT over siding. Tack the soffit with a couple 6d common nails. Installing 2x4 tie plates in a later step will provide more nailing.
2. Install (5) five more siding panels. Cut the last soffit flush with the 2x4 wall plate.

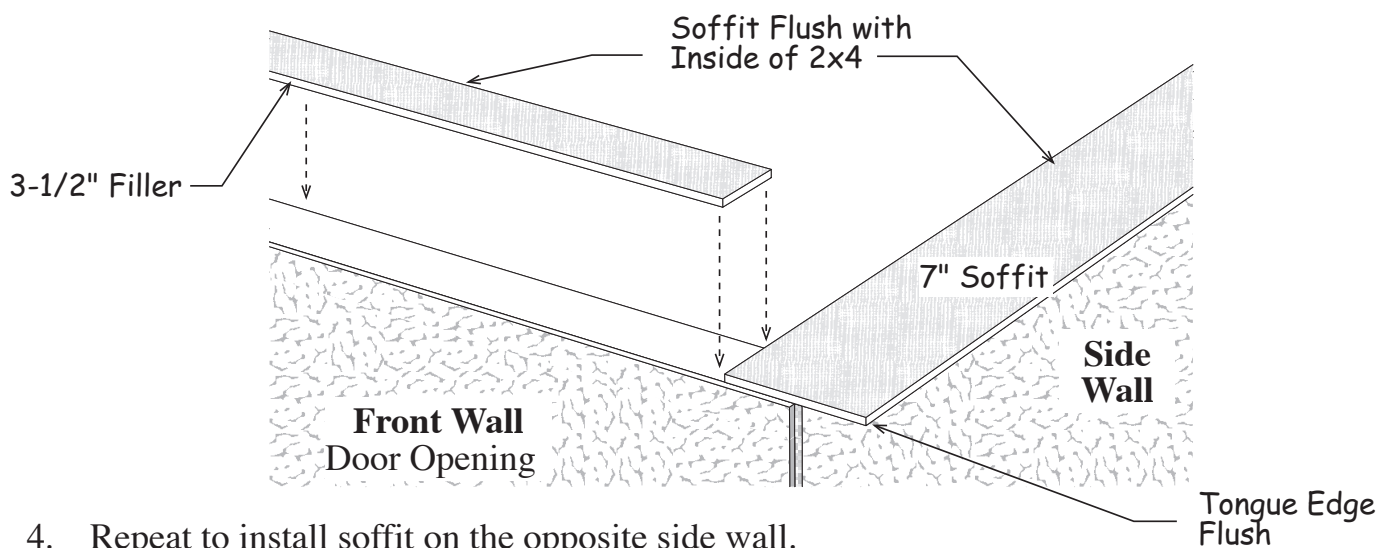

4. Repeat to install soffit on the opposite side wall.
5. Install (3) three 3-1/2" wide x 48-3/4" filler panels over the front and back wall. Cut the last filler to fit between the soffit on the side walls.

Step 9 Install Roof Gables

1. Install a gable frame centered on the back wall. Gable plate should be flush with filler. NOT over siding. Secure with 10d sinkers.
2. Install the gable frame on the front wall.

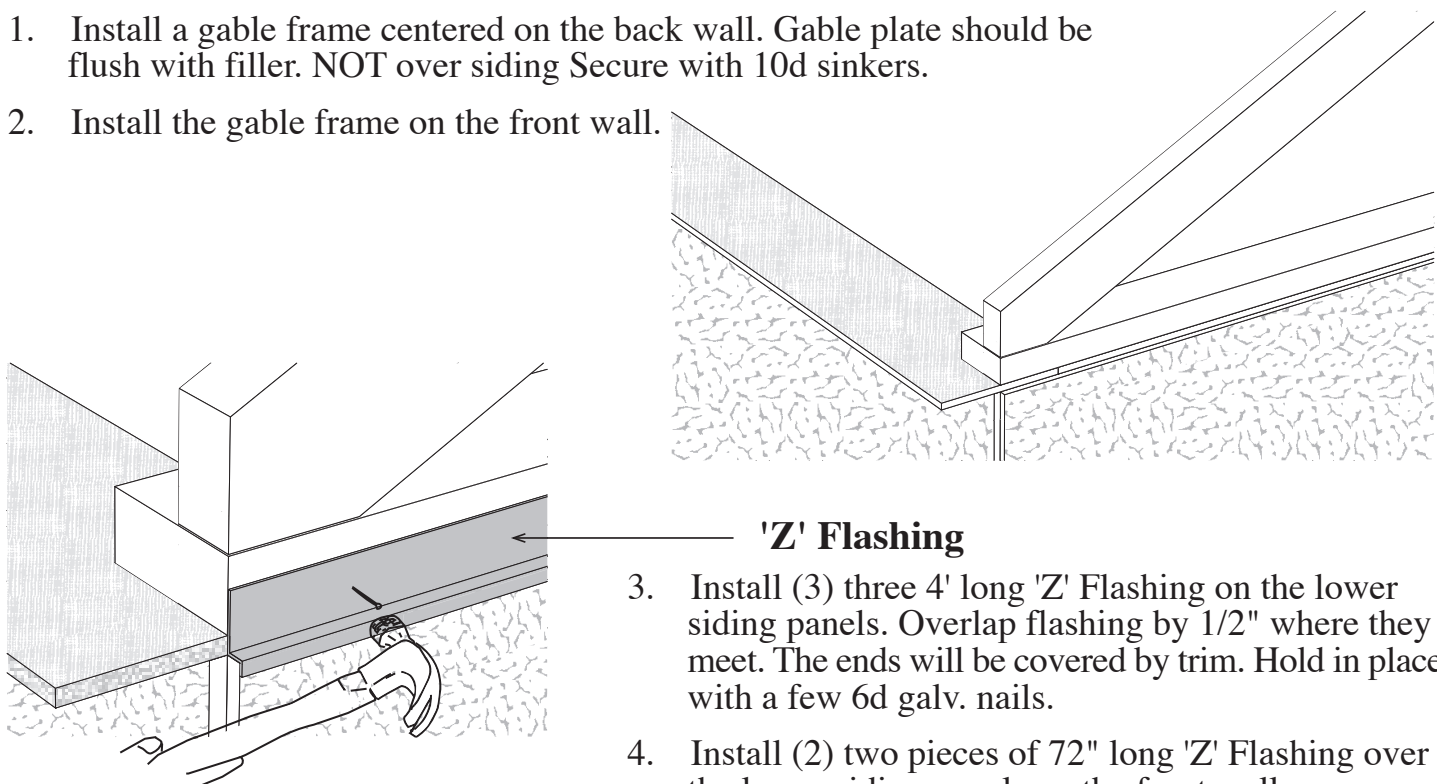

Step 10 Install Siding on Gables

 Gable siding is factory cut to be installed either working from left to right or right to left. Regardless of the direction always begin with the 'LAP' Edge flush with end of the gable.

1. Locate pre-cut gable siding. Install with 'LAP' edge flush with end of gable frame. When properly set there will be a slight gap between the 'Z' flashing and bottom edge of siding. Use 6d galv. nails spaced 8" apart.
2. Install center gable siding. Cut last panel flush with end of gable frame.
3. Repeat to install siding on the other gable frame.

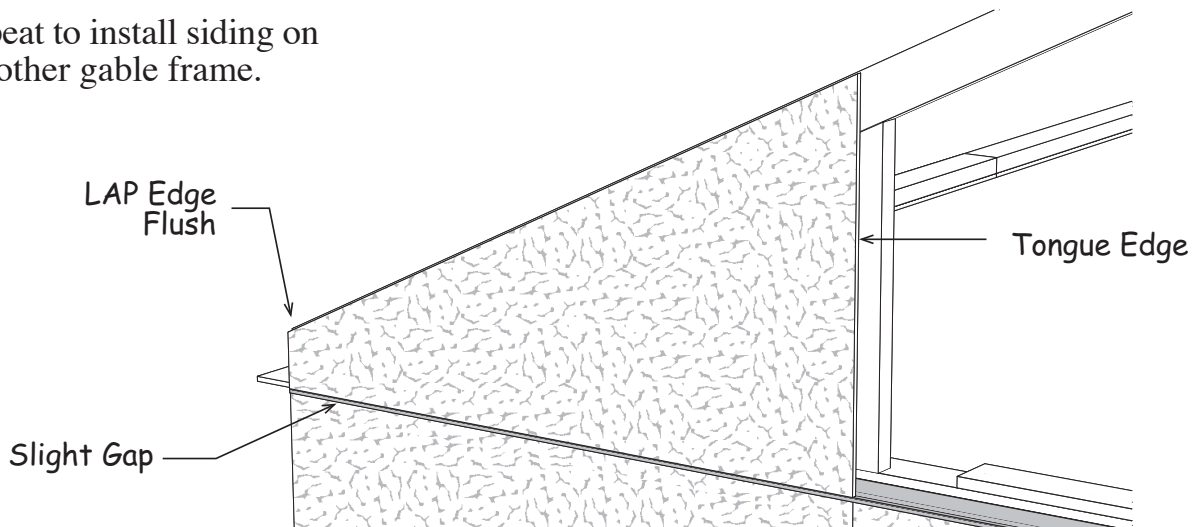

Step 11 Install 2x4 Tie Plates on Side Walls

1. Install a 2x4-12' on a side wall against the gable on the back wall. Install another 2x4x12'. Cut length to fit. Use 10d sinkers.
2. Repeat to install tie plates on the opposite side wall.

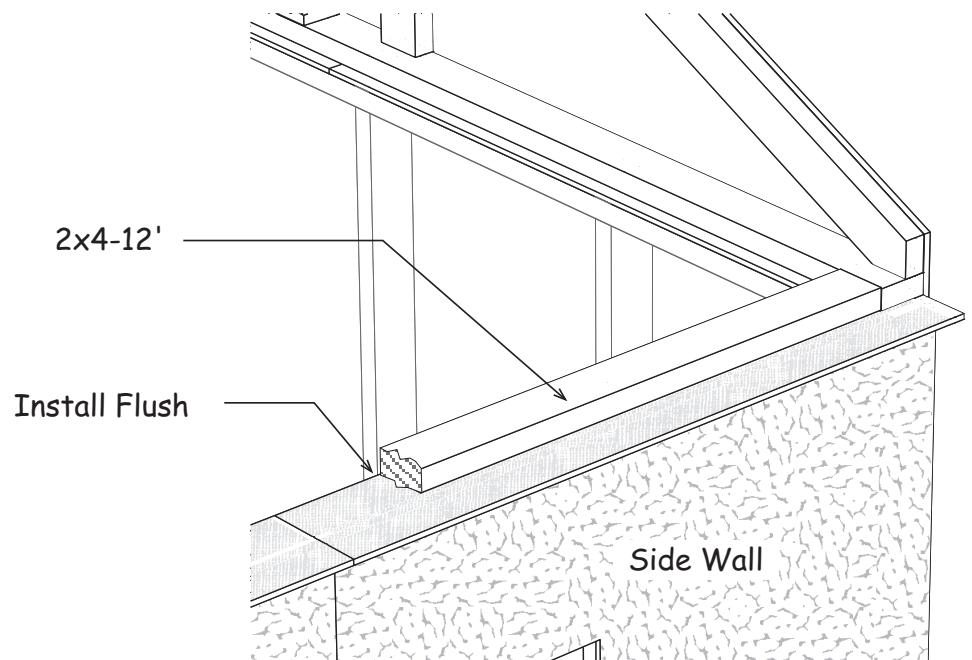

Step 12 Layout Roof Trusses & Install Soffit Blocks

1. Starting on back corner measure from the backside of the 2x4 gable frame when marking the location of the first truss. Continue 24" spacing to other gable. **Important:** When marking the opposite wall, place the 'X' mark on the same side of the line so your trusses are parallel when they are installed.
2. Install metal hangers to the tie plate with 1-1/2" hanger nails. The opening should line up with the 'X' mark, the bottom of the opening, flush with the 2x4 tie plate. **Detail 'D'**.

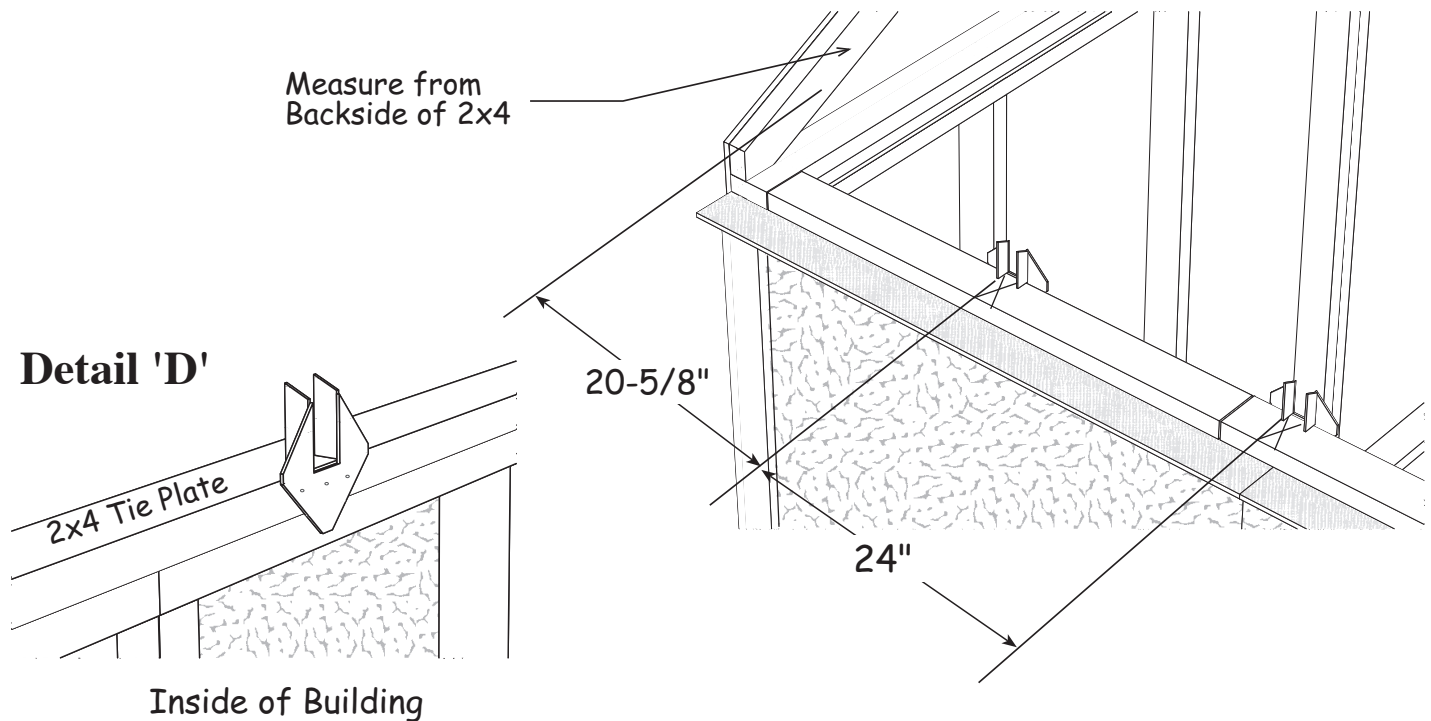

3. Set roof trusses. Secure trusses to metal hangers with 1-1/2" hanger nails.

4. Gather (22) twenty two short 2x4 blocks and install one at both ends of each truss. Secure 2x4 blocks to the soffit panel using (2) two 1-1/2" long exterior screws.
5. Gather (4) four more 2x4 blocks. Install one 2x4 block at each end of the soffit, flush with the 2x4 gable frame.

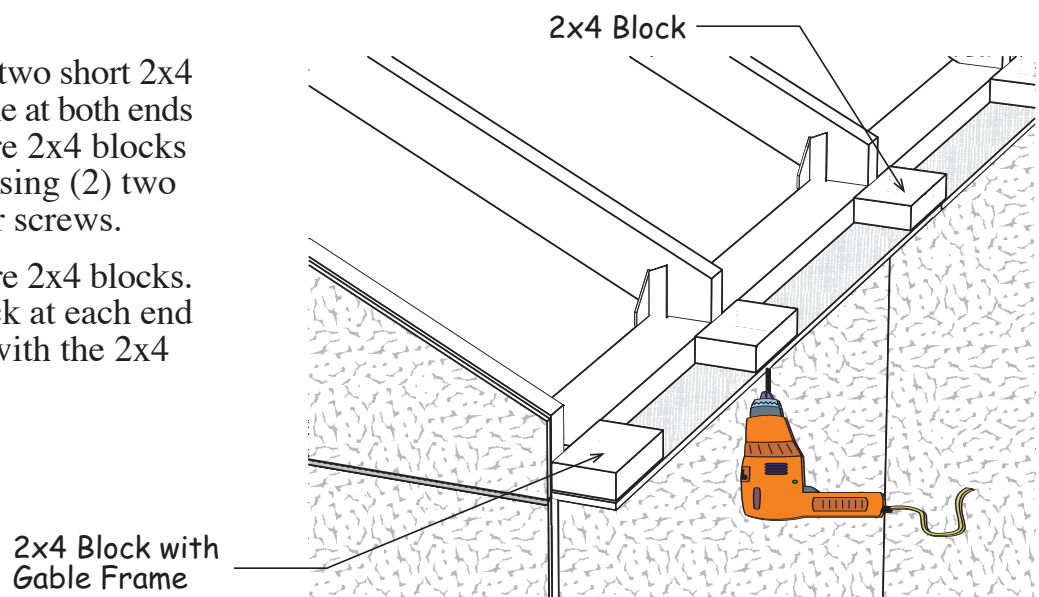

Step 13A Install Trim

1. Install (4) four small primed siding fillers, *packed with the hardware*, over the 2x4 soffit blocks. Siding fillers will be flush with the gable siding. Use 6d galv. nails.

Siding Filler

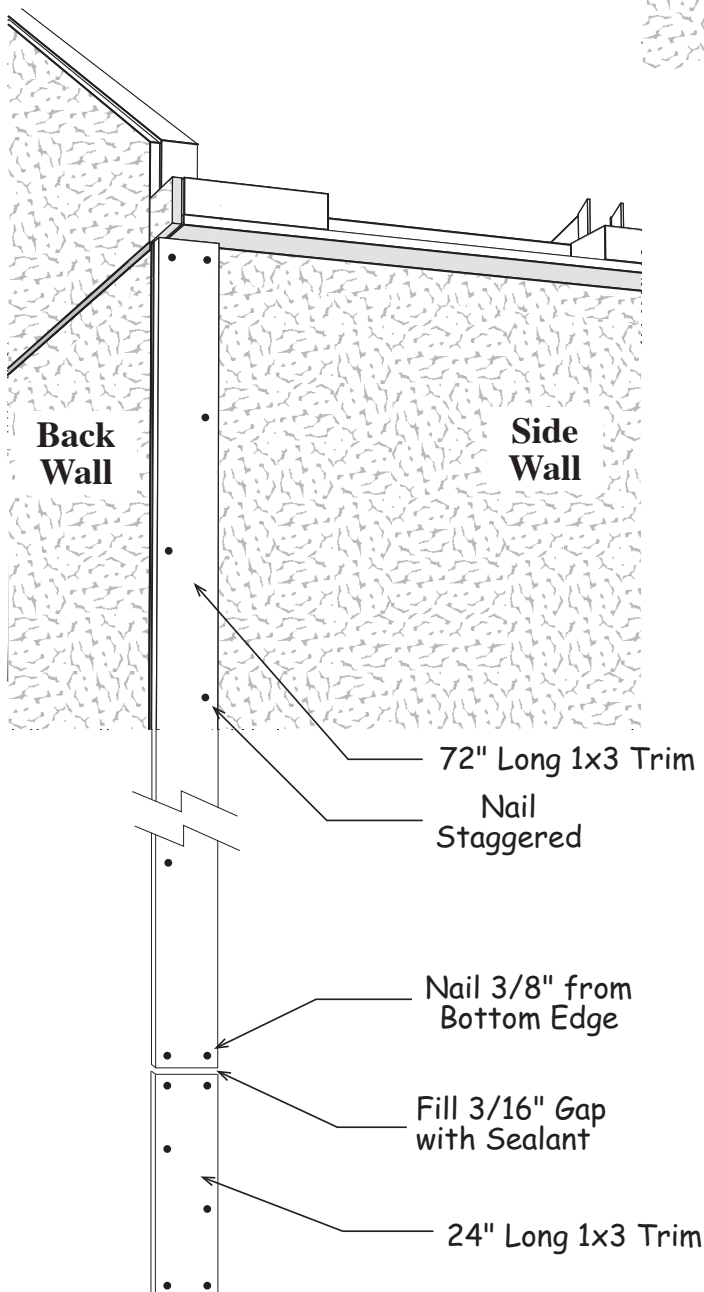
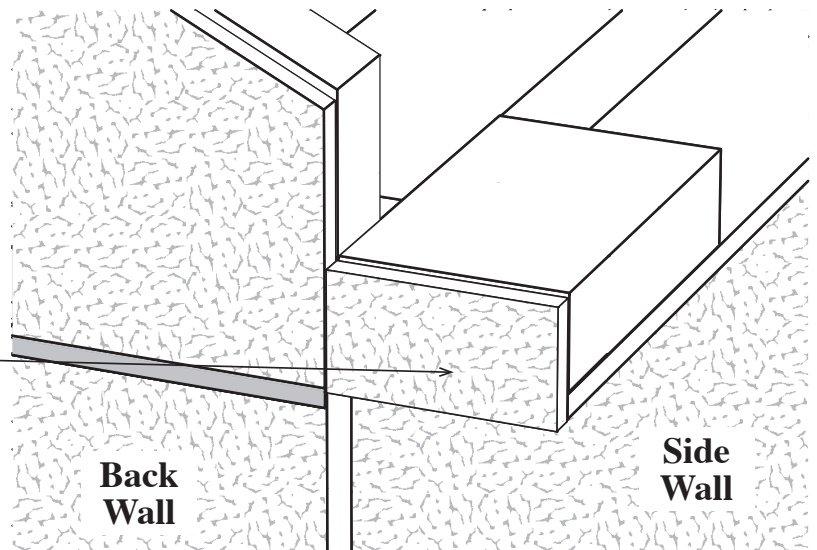

When installing trim in later steps space nails and seal as described in this step.

2. Locate (4) four 24" and (4) four 72" long 1x3 trim boards. Install 72" long boards on side walls at corners under soffit flush with siding on back wall. Nail with (2) two 6d galv. nails $\frac{3}{8}$ " from top and bottom of board. Then nail staggered along board 12" apart. *See diagram.*
3. Install 24" long boards under 72" long boards. Leave a gap of $\frac{3}{16}$ " to allow for sealant to fill gap. If necessary cut trim to be flush with bottom of siding. Fill gap with sealant.
4. Repeat on remaining side wall corners.

Step 13B Install Trim

 *Do not install gable trim on front in this step.*

5. Install a 8-1/2" long trim board, *called a keystone*, at the top of the gable flush with the top of the gable frame. Use 6d galv. nails.
6. Locate (2) two 82-1/2" long 1x4 trim boards. Butt each board against the keystone and flush with the top of the gable frame. Use 6d galv. nails.

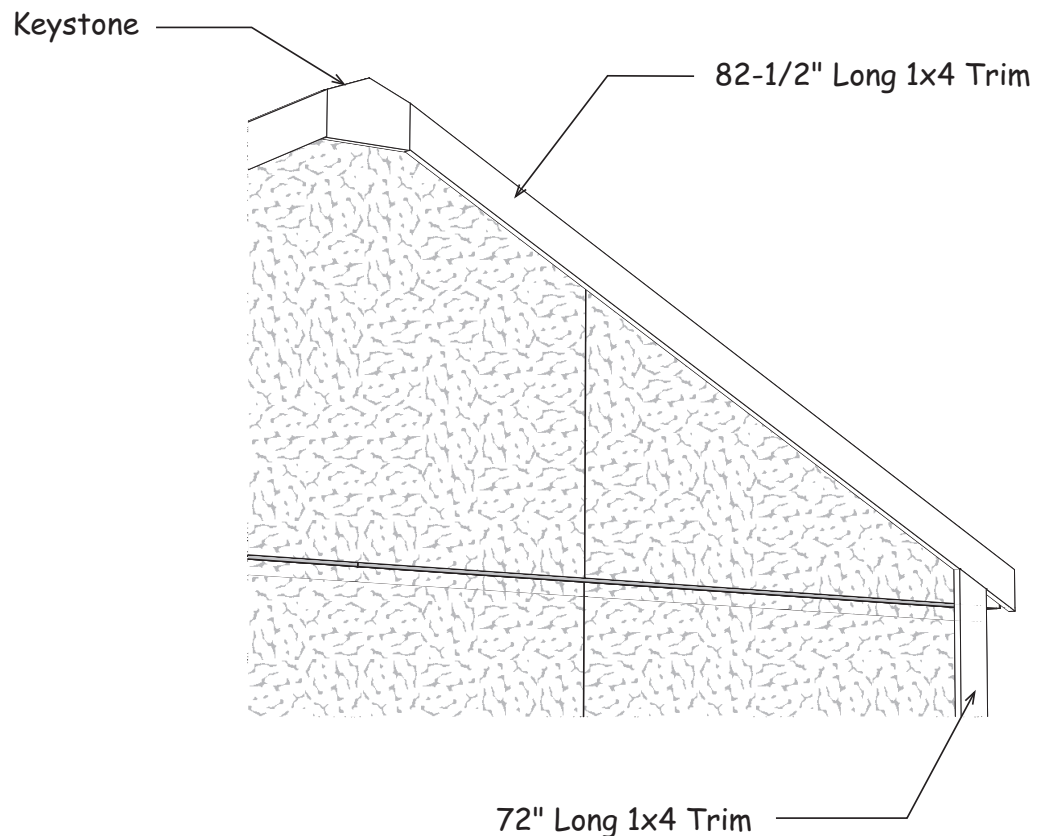

7. Locate (2) two 72" long 1x4 trim boards with angle cut on one end. Install (1) one on each corner flush with the 1x3 corner trim on the side wall and under gable trim. Use 6d galv. nails.
8. Locate (2) two 27" long 1x4 trim boards and install under 72" long boards. Leave a gap of 3/16". If necessary cut trim to be flush with bottom of siding.

Step 14 Install Fascia on Side Walls

1. Install a 1x4-4' fascia board against the rear gable trim. Install the fascia so the bottom edge of the roof sheathing will rest on the edge of the 1x4. **See Detail 'E'**. Use a straight edge to align the 1x4 board with the top of the trusses. Use 6d galv. nails.
2. Install (3) three more 6' fascia boards. Do not install the last fascia board. This will be applied after the front overhang is installed.
3. Repeat on opposite side wall.

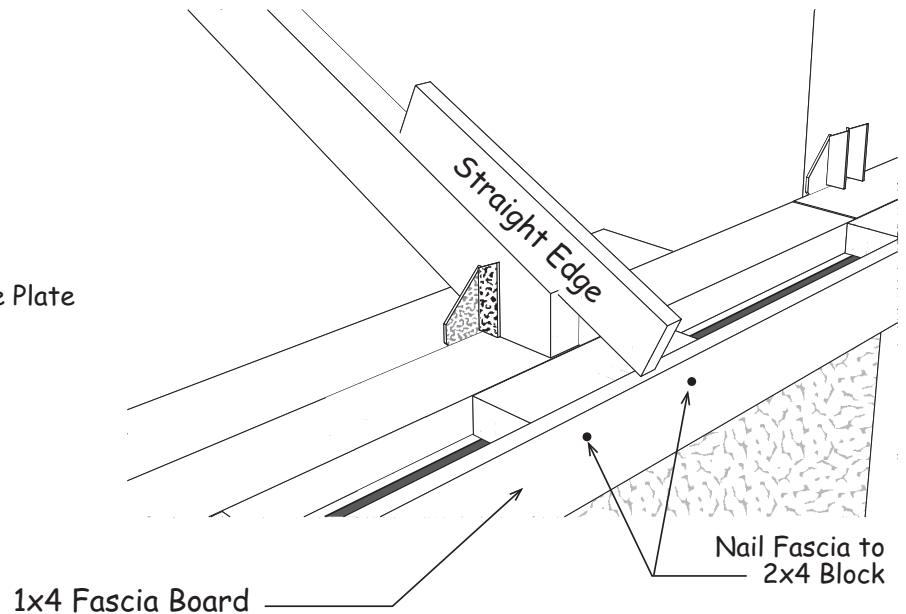
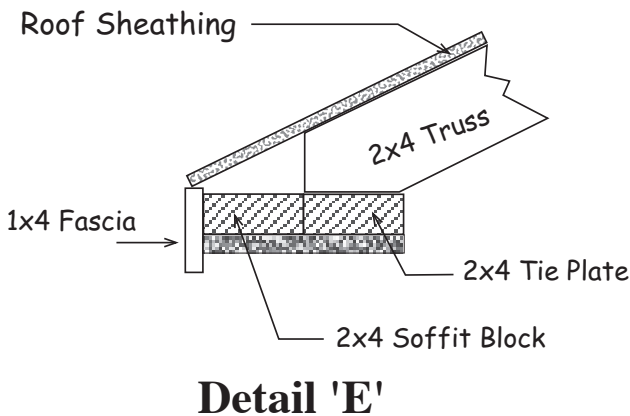

Step 15A Install Roof Sheathing

1. Install (4) four 42-3/8" long 2x3 boards on the front gable flush with the top of the gable frame. Use 10d sinkers
2. Plumb each truss and gables.
3. Refer to sheathing layout at the top of the next page. Install roof sheathing starting at the front gables lower corner. The roof sheathing should extend 6-1/4" beyond the 2x3s. Continue to back wall. Use 6d common nails spaced 8" apart. The top row of roof sheathing will be about 1" below the ridge to allow for optional ventilation.

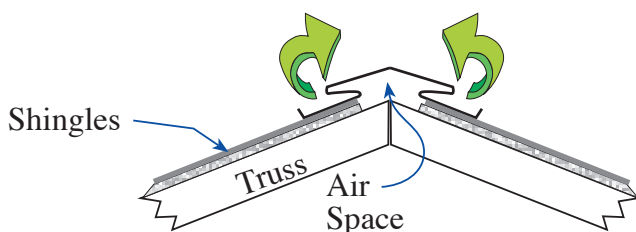
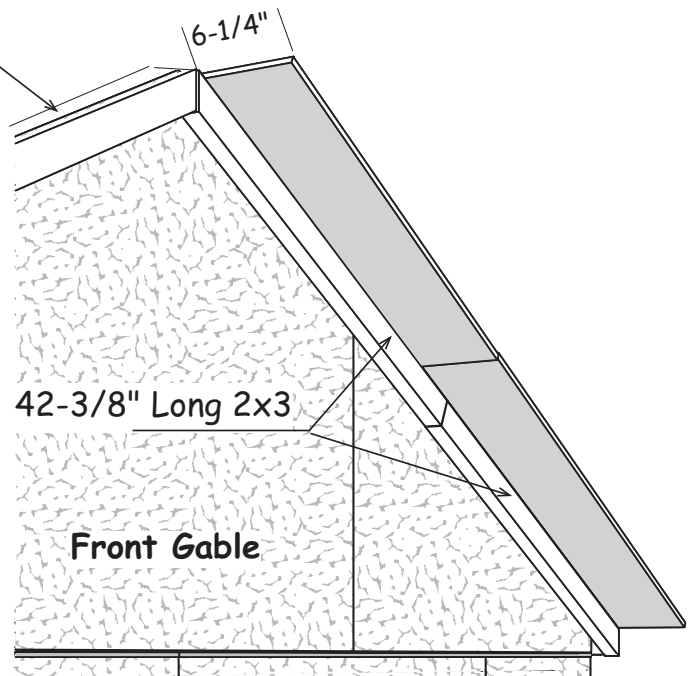

Step 15B Install Roof Sheathing continued

 Sheets should meet at center of trusses when installed

- From 4x8 sheets of OSB cut to the sizes indicated with an * below. Repeat for opposite side.

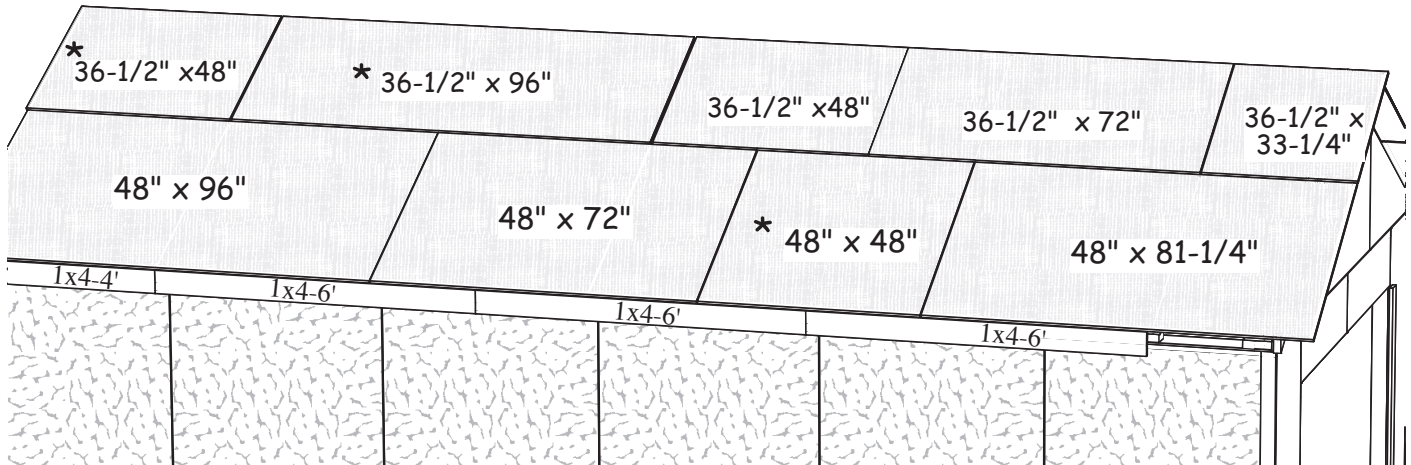

- Trim off any sheathing that extends over the rear gable trim.

Step 16 Install Front Soffit

- Gather (2) two 7" wide soffit panels. Install first panel flush with lower end of 2x3 and against siding. Install with 1-1/2" exterior screws. Cut upper panel to fit.
- Install (2) two 42-3/8" long 2x3s between the roof sheathing and the 7" soffit panels. Install with 1-1/2" exterior screws on soffit and 6d common through roof sheathing. Set these boards flush with soffit panels. The roof sheathing will extend 3/4" past the 2x3s to allow for trim.

- Repeat on other side.

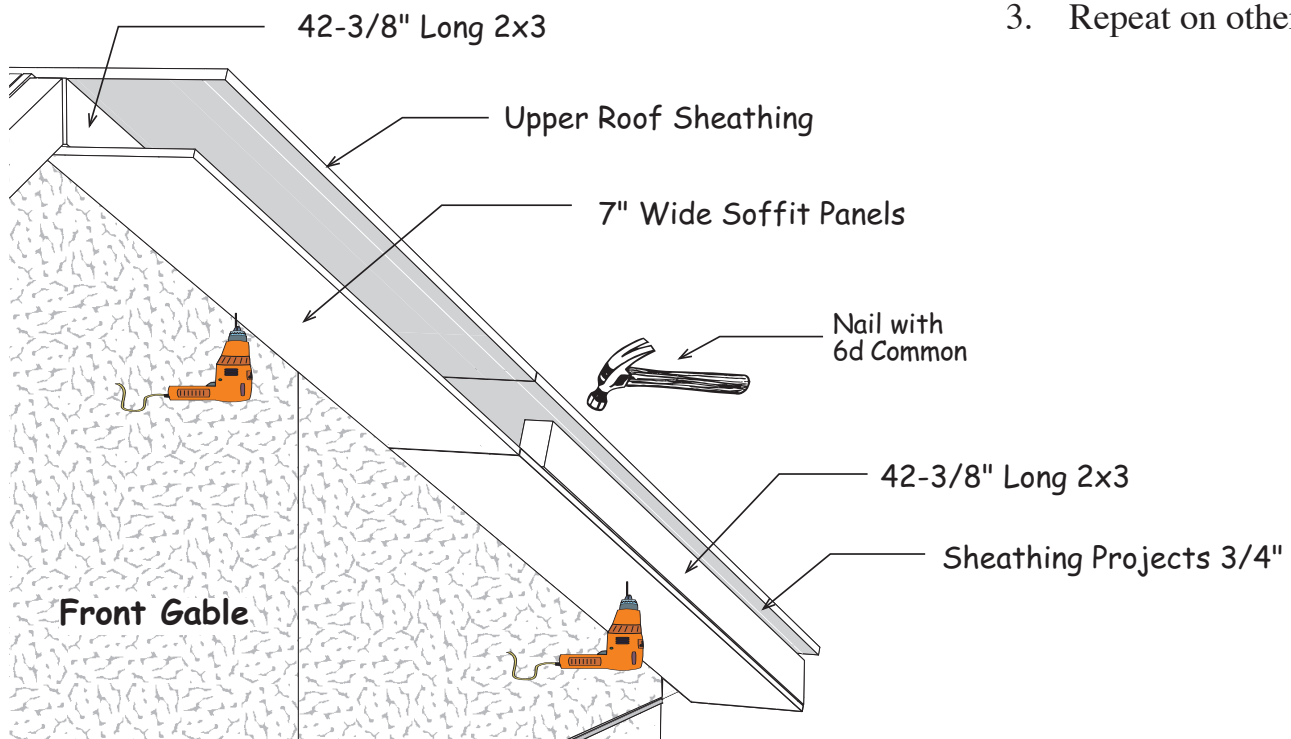

Step 17 Install Gable & Door Trim

1. Install gable trim under the roof sheathing as done in **Step 13**.

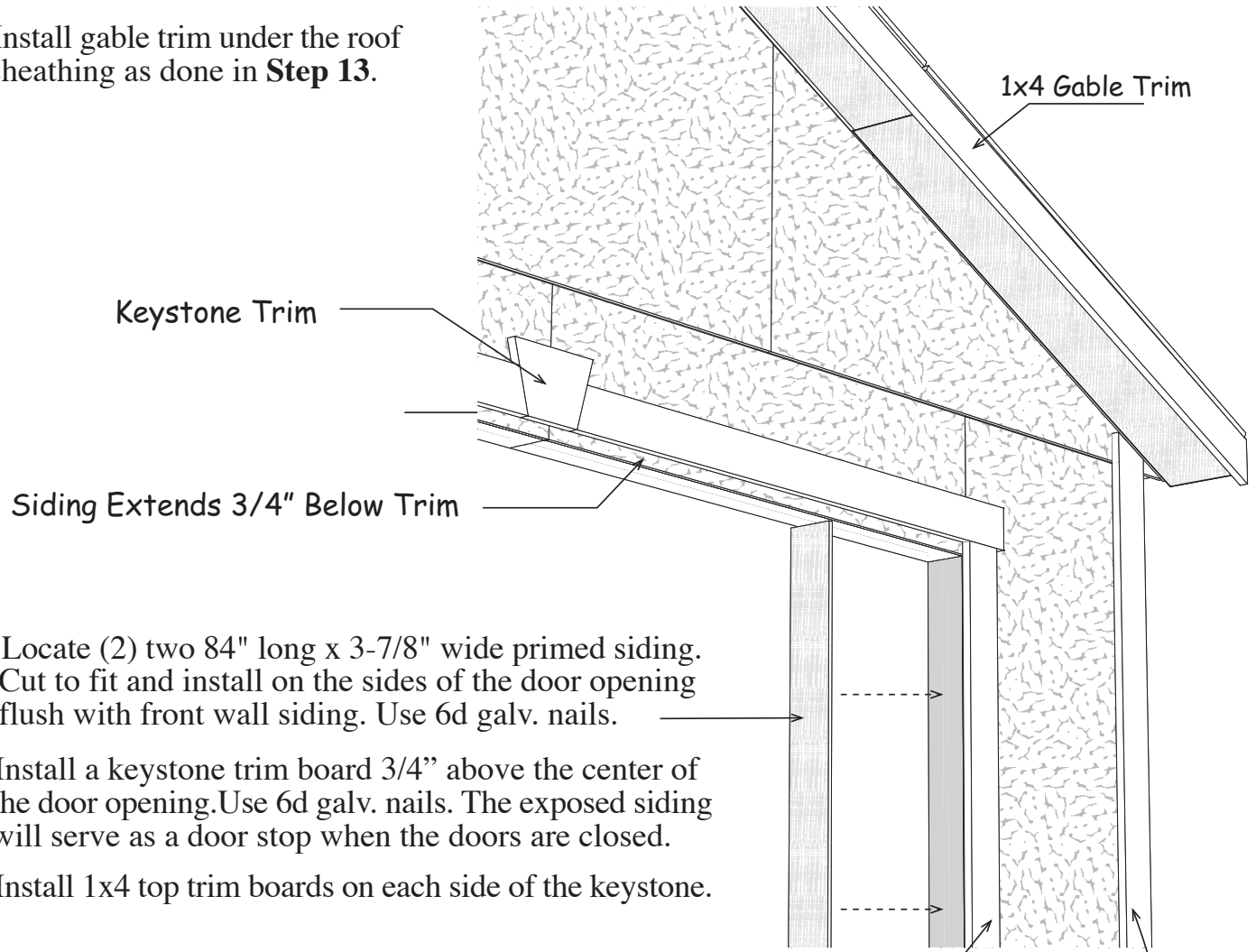

2. Locate (2) two 84" long x 3-7/8" wide primed siding. Cut to fit and install on the sides of the door opening flush with front wall siding. Use 6d galv. nails.
3. Install a keystone trim board 3/4" above the center of the door opening. Use 6d galv. nails. The exposed siding will serve as a door stop when the doors are closed.
4. Install 1x4 top trim boards on each side of the keystone.
5. Install (2) two 1x4-84" long trim boards flush to the sides of the door opening flush with jamb. Tack these boards with a couple nails, you may want to reposition the trim when you install the doors.
6. Install (2) two 72" long 1x4 and (2) two 27" trim boards flush with the 1x3 corner trim on the side walls. Use 6d galv. nails.

Step 18 Finish Side Wall Trim

1. Locate (2) two 1x4-4' trim boards. Cut each to fit against back of front gable trim and install on the side walls.

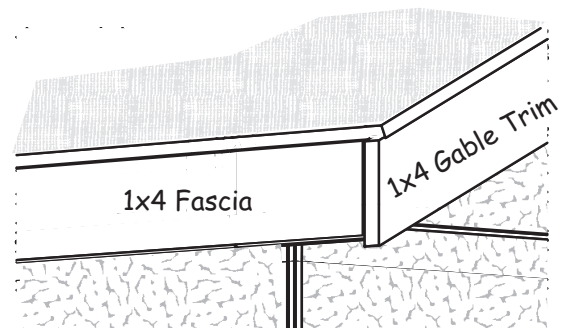

Step 19 Install Door Stop on Left Door

Qty.	Material Shipped in 48" Door Kit
2	ea. 48" x 84" Pre-built Doors
2	ea. 12" x 42" Transom Windows
2	ea. 1x4" x 84" Door Trim
2	ea. 1x4" x 48-3/4" Door Trim
1	ea. 1x6" x 10" Keystone
2	ea. 3-7/8" x 84" LP 3/8" Primed Door Jamb
6	ea. 6" Door Hinges
1	ea. Door Handle & Latch
2	ea. 6" Barrel Bolt
52	ea. 2" Hinge Screws
16	ea. 3/4" Pan Head Screws
10	ea. 1-1/2" Exterior Screws
32	ea. White Window Screws

Install a 4-1/4" x 83" long board as a door stop to the right side of one of the doors. This will be the left door when installed. The door stop should extend 3/4" beyond the frame of the door. Install with 1-1-2" exterior screws packed in the main component kit. Space screws 12" apart.

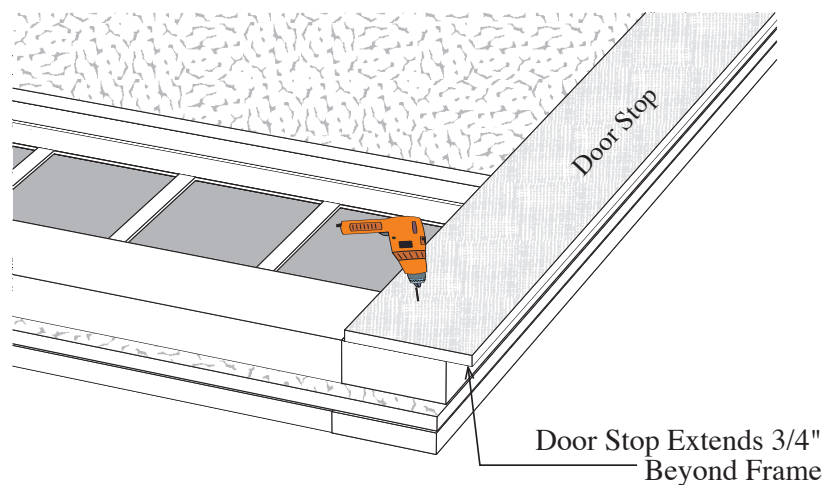

Step 20 Install Doors



If your door opening is out of square, the space around the doors will not be even. You can remove and re-position the side trim to make allowances for this. The side trim does not have to be flush with the frame of the door opening. You can move the trim in or out to make the door spacing equal.

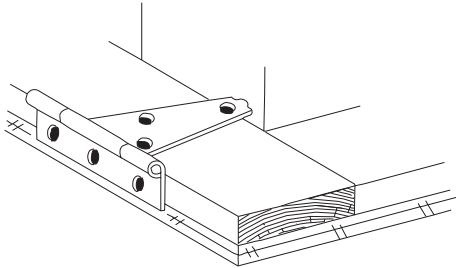

1. Install (3) three 6" hinges to sides of the doors. To position the hinge properly, hold the rectangular plate against the frame. Use 2" black screws.
2. Before fastening the hinges to the trim, temporarily prop the doors in the opening. Leave a space at the top and between the doors and the side trim to allow room for the doors to expand due to humidity.
3. Determine position of hinges and install to side trim with 2" screws.
4. Install the window using the short white screws.
5. Install door handle using 2" black screws into the pre-drilled hole on right side door. When the handle is turned the inside latch will hold doors closed. Tighten set screw to finish.

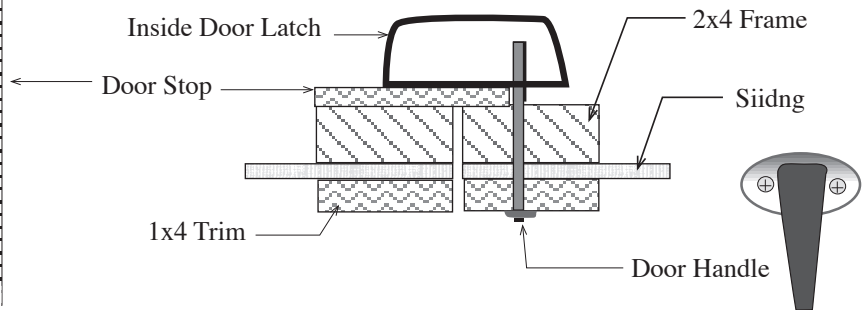
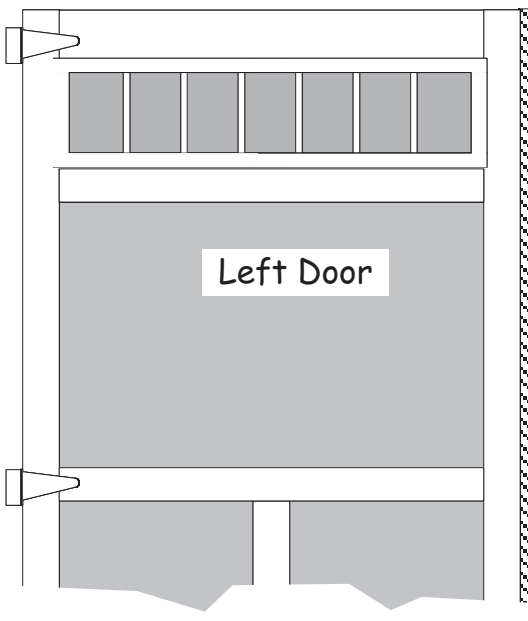

6. Install a barrel bolt using 3/4" pan head screws on the lower back of the door to secure this door in place when closed. You will need to drill a hole for the round shaft to drop into.
7. Install another barrel bolt at the top of the door.

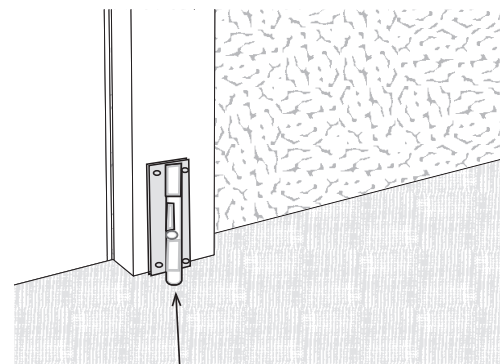

Barrel Bolt on the back of left door

Packing List

7	2x4 for Collar Ties	82"
18	2x4 for Truss Rafters	80-1/2"
4	2x4 for Gable Studs	23-1/2"
18	2x4 for Soffit Blocks	5" or longer
6	1x4 for Side Wall Fascia	72"
4	1x4 for Gable Trim	82-1/2"
4	1x4 for Corner Trim	72"
4	1x4 for Corner Trim	27"
4	1x3 for Corner Trim	72"
4	1x3 for Corner Trim	24"
8	2x3 for Gable Overhang	42-3/8"
14	Truss Gussets	7/16" 8" x 16"
2 ea	Siding Panels	20" x 48-3/4"
2 ea	Gable Siding	48" x 40" <i>angle cut</i>
4 ea	Gable Siding	48" x 28" <i>angle cut</i>
12 ea	Soffit Panels	48" x 7"
6 ea	Soffit Fillers	48" x 3-1/2"
4 ea	Siding Fillers	2" x 3-1/2"

4	lbs.	10d	Sinkers
5	lbs.	6d	Galv.
5	lbs.	6d	Common
2	lbs.		Hanger Nails
100	ea.	1-1/2"	Exterior Screws
125	ea.	2-1/2"	Deck Screws
6	ea.	1"x4"	Metal Plates
2	ea.	72"	'Z' Flashing
3	ea.	48"	'Z' Flashing
14	ea.	H1	Metal Truss Hangers
2	ea.	1x6 Keystone	8-1/2"
2	ea.	Sheathing 7/16"	48" x 81-1/4"
2	ea.	Sheathing 7/16"	48" x 72"
2	ea.	Sheathing 7/16"	36-1/2" x 72"
2	ea.	Sheathing 7/16"	36-1/2" x 48"
2	ea.	Sheathing 7/16"	36-1/2" x 33-1/4"
2	ea.	Header Filler 7/16"	7-1/4" x 48"
<i>Additinal material not used in this model</i>			
2	ea.	Door Jamb 3/8"	5-3/8" x 48"
2	ea.	Door Jamb 3/8"	5-3/8" x 84"

Qty.	<i>Material Supplied by Local Supplier</i>	
44 pcs.	2x4	Pre-cut Wall Studs
12 pcs.	2x4 - 12'	Wall & Tie Plates
6 pcs.	2x4 - 12'	Treated Wall Plates
2 pcs.	2x8 - 10'	Door Header
16 pcs.	Exterior Siding	4x8
6 pcs.	OSB Sheathing	4x8
2 lbs.	16d Galv. Nails	

Roof Covering (not included)

14 bdl.	Roof Shingles
10 pcs.	Roof 'drip' Edge-10'

Qty.	<i>Material Shipped in 4' Extension Kit</i>	
2	2x4 Collar Ties	82"
4	2x4 Truss Rafters	80-1/2"
2	1x4 Side Wall Fascia	48"
4	2x4 Soffit Blocks	5" or longer
4	H1 Metal Truss Hangers	