

# JMT12 MOBILE

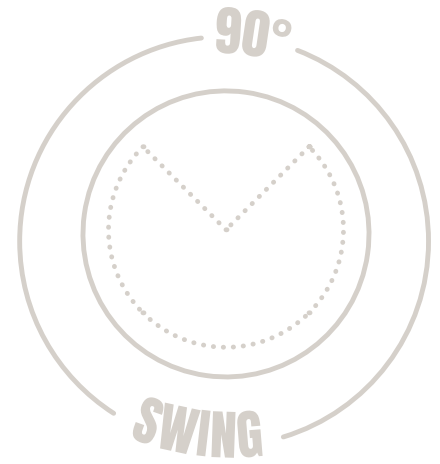

## Manoeuvrability

Lifting eyes get the JetMister into difficult areas. Heavy-duty pneumatic wheels for site mobility.

## Jet nozzle

Push button positioning or auto 45° and 90° swinging nozzle.

## Tilting mast

Heavy-duty mast with 0-30° tilt positioning for reaching high areas. Can also be positioned for transport.

## Easy controls

Simple control operation to start/stop pump and move jet automatically from left to right. Emergency stop and warning signals.

## Just add water!

A 1/2" quick release connector for a water hose. Just connect bowser or mains feed with potable water.

## Electric powered

110V 32amp powered with geared motor for easy prime.

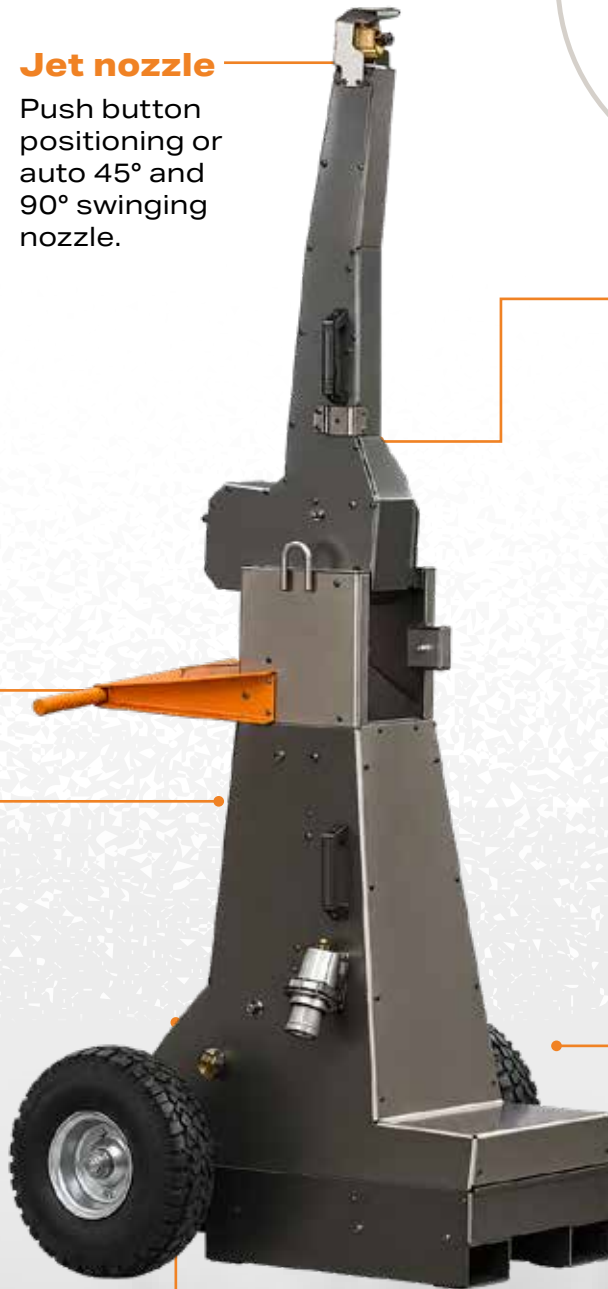

## Fine Mist

15m - 20m throw of fine mist at only 12 lpm. Water saving advantages.

## Easy Remote

Optional remote control JetMisters from 100m away.





### Versatility

Mobile Dust Suppression Jet Misting Tower with an electric powered pressure pump that can be positioned in locations to control heavy dust issues. The tower unit will throw a water mist of up to 20 meters with the option of 45° or 90° auto oscillations. Easy to position and then plug in water and power for quick operations.

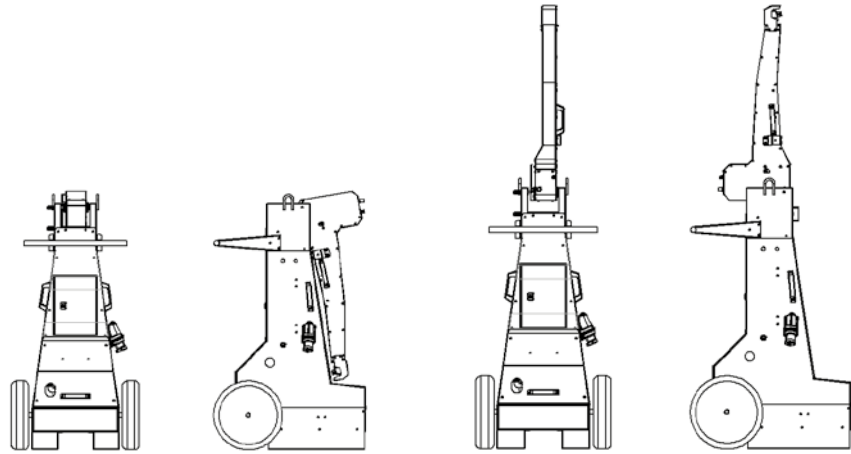

**PRODUCT SPECIFICATIONS**

	JMT-12-110V
Electric Motor	110v 50HZ
Electric Connection	32 AMP
Pressure - Bar (PSI)	60 (870)
Flow Rate - LPM (USGPM)	12 (3.1)
Ave Mist water Droplet Size	180-200 µm
Dimensions LxWxH - mm (inch)	890x750x2440 (1510 mast folded)(35" x 30" x 96 (59"))
Weight - Kg (Lbs)	120kg / 265lbs
Mist Distance (With Breeze) - M (Ft)	15-20m / 50-65 ft
Horizontal Oscillation	45° & 90°
Vertical Tilt	0° - 45°
Max Water Feed Pressure - Bar (PSI)	3 Bar (43)
Crane Lift Facility	Yes
Fork Lift Facility	No
Water Quality	Drinking Water Quality