

JMRT35-2000 BOWSER

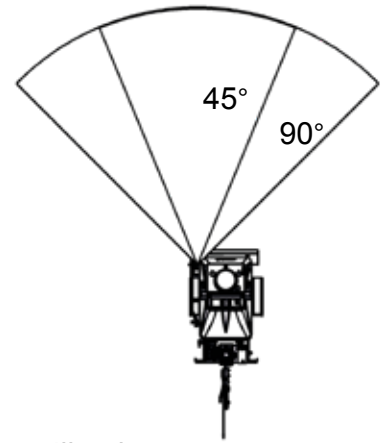

The JetMister Bowser is a revolutionary dust-suppression bowser that will solve your construction and demolition site dust issues and pressure wash heavy plant. The integrated unit can be deployed in minutes giving you immediate dust control. The tank can continue to operate as a reservoir with mains water connected.

Jet nozzle

Push button positioning or auto 45° and 90° swinging nozzle.

Tilting mast

Heavy-duty mast with 0-30° tilt positioning for reaching high areas.

Easy controls

Simple control operation to start/stop pump and move jet automatically from left to right. Emergency stop and warning signals.



Mobility

Road tow-able 2000 Litre water bowser to EU specification for easy transporting with water. Totally self-contained dust suppression unit.

Diesel power

Yanmar diesel engine with electric start and dry run protection.

Protection

Heavy-duty galvanised chassis frame will last you in harsh environments.



Quick scan
Operation video

SUPPRESSION BOWSER

When and where you need it

High pressure mist can be directed and particle size can be adjusted to suit all types of dust and wind direction.

Self-contained suppression and jet washer

JetMister is easy to locate, position and operate quickly with its own power supply for pressurised misting. The auto swing nozzle means you can attack the dust in remote locations very economically. Its 1000L clean water tank capacity will provide constant dust suppression for up to 30-70 mins.



JMRT35-D-2000

JMRT35-P-2000

PRODUCT SPECIFICATIONS

	JMRT35-D-2000	JMRT35-P-2000
Engine / Motor	Yamar L100	Vanguard 400 EFI
Fuel Type	Diesel (HVO)	Petrol
Fuel Tank Size - Ltr (USG)	5.4 (1.5)	5.9 (1.55)
Fuel Consumption Ltr/Hr (USG/Hr)	1 Ltr (0.25G)	2 Ltr (0.5G)
Emissions Standard	Stage V	Stage V
Power - Kw (HP)	6.8 (9)	10 (14)
Pressure - Bar (PSI)	60 (870)	60 (870)
Flow Rate - LPM (USGPM)	40 (10)	40 (10)
Number of Nozzles	1	1
Ave Mist water Droplet Size	200-250 µm	200-250 µm
Dimensions (LxWxH) - mm (inch)	3900 x 1850 x 1650 (154" x 73" x 65")	
Weight	920Kg Excluding 2000 Ltr Water	
Mist Distance (With Breeze) - M (Ft)	3000 (6600)	3000 (6600)
Horizontal Oscillation	15-35m / 50-115 ft	15-35m / 50-115 ft
Vertical Tilt	45° & 90°	45° & 90°
Generator Power Required - Kva	0° - 45°	0° - 45°
Standard Mist Hose Length - M (Ft)	60m (195 Ft) at 1m (3Ft) Nozzle space 120m (290 Ft) @ 2m (6Ft) Nozzle space	
Max Water Feed Pressure - Bar (PSI)	3 Bar (43)	
Warranty Period	12 Months	
Fork Lift Facility	Option for empty tank	
Water Quality	Drinking Water Quality	
Trailer Max Axle Capacity - Kg	3000 (6600)	3000 (6600)
Water Tank Capacity Ltr (USG)	2000 (520)	2000 (520)