



Forklift Moving Line of Dots Light Projector

SPECIFICATION SHEET

Overview

SafetyCast™ Hazard Illumination Forklift Moving Line of Dots Light projector provides visual warning to pedestrians and vehicles in accident prone areas, or areas where pedestrians share floor space with mobile industrial handling equipment, such as warehouses, dock and loading areas or any industrial workplace pedestrians. This solution is extremely effective in noisy areas where audible alarms can be drowned out, or where multiple alarms may confuse the pedestrian. The product is weatherproof, thus ideal for indoor and outdoor use.

Key Features

- Easy to install on any forklift or crane in minutes
- Adjustable mounting bracket allows for easy positioning of the beam on the floor
- High visibility illuminated projections provide the pedestrian with clear knowledge of their proximity to moving equipment
- Weatherproof and ideal for indoor/outdoor use
- Run off 10-110VDC

Specifications

Amp Draw:	1.6A@12V, 0.8A@24V
Rated Power:	20W
Voltage Max:	110V
Light Colour:	Red, Blue
Projection Type:	4 Points Flowing (Moving)
Temperature Range (°C):	-45~80°C
Operating Voltage:	10-110 V DC
IP Rating:	IP67 Compliant - Dust/Water Ingress
CE Compliant:	Yes
Weight:	360g
Thermal Management System:	Integrated
Pressure Equalizing Vent:	Available
Protection:	EMC Protection , Reverse Polarity Protection
Material:	UV Resistant Powder Coat, High-Grade Aluminum Alloy, Impact Resistant Polycarbonate Lens
Standard Warranty:	Limited Lifetime Warranty
Lifespan:	30.000+ hours
Cable Length:	3.5m

Dimensions

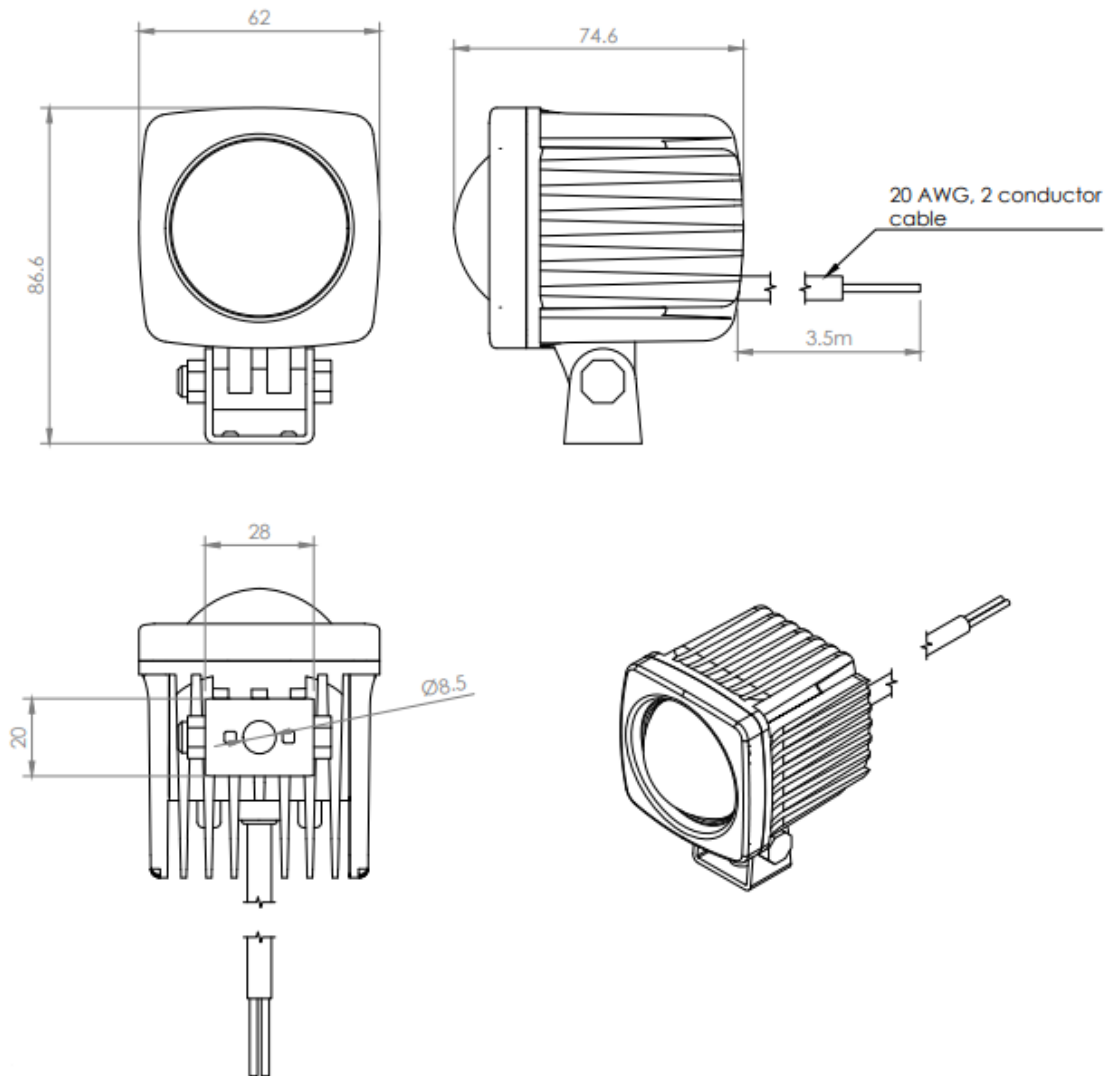

E&OE: Data included in this sheet may be subject to change without notice. Please confirm critical specifications with our staff prior to ordering.