

OPERATION & MAINTENANCE MANUAL

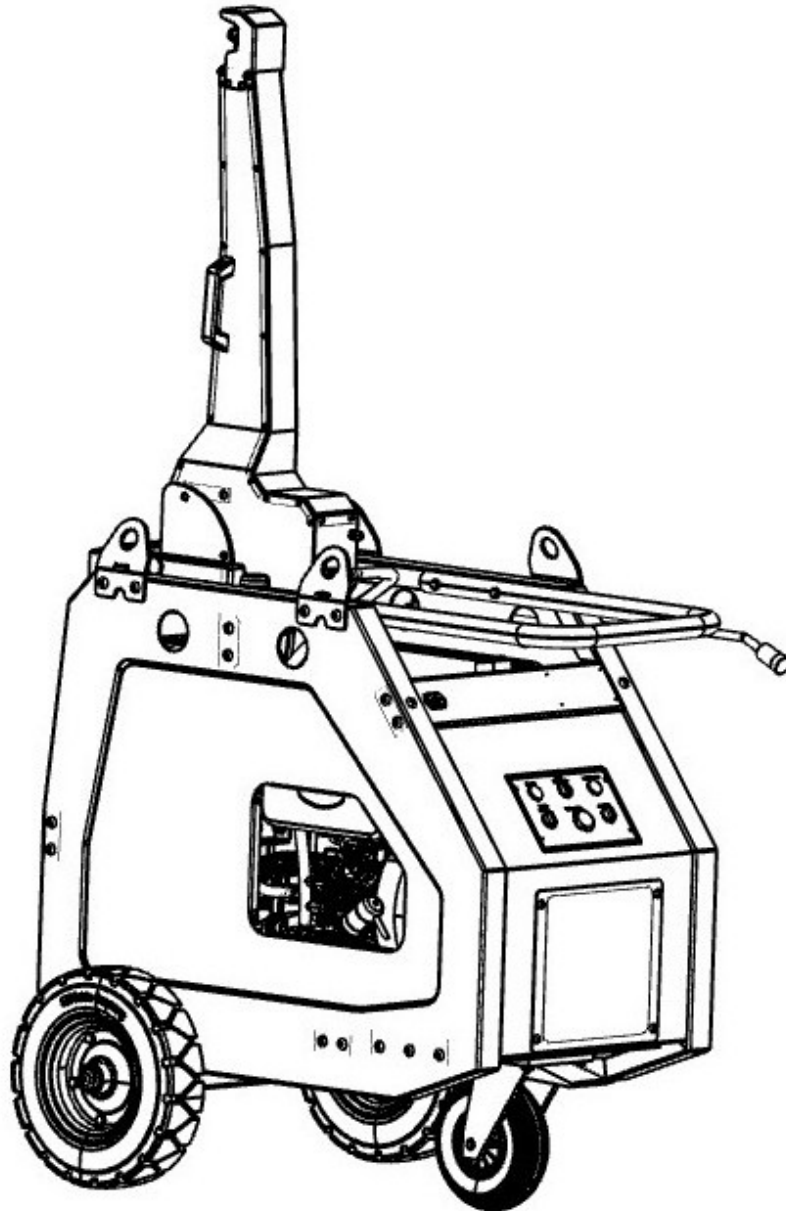

JetMister Series **JM35-D** Diesel Portable Dust
Suppression Machines

IMPORTANT

Read, understand and obey these safety rules and operating instructions before operating or maintaining this machine

Only trained and authorized personnel shall be permitted to operate this machine. This manual should be considered a permanent part of your machine and should remain with the machine at all times. If you have any questions, please contact Dustquip

CONTENTS	PAGE NO
SPECIFICATION SHEET	3 - 4
INTRODUCTION & GENERAL INFORMATION	5
WARRANTY CONDITIONS	6
SAFETY	7 - 8
LEGEND	9 - 10
DECALS	11
CONTROLS	12
PRE-OPERATION INSPECTION	13 - 14
MAINTENANCE	15 - 22
FUNCTION TESTS	23 - 24
WORKPLACE INSPECTION	25
OPERATING INSTRUCTIONS	26 - 29
TRANSPORT INSTRUCTIONS	30 - 31
SPECIFICATIONS	32
BIO-DIESEL FUELS	33
WIRING DIAGRAM	34
LEGIONELLA HEALTH RISK	35
MANUFACTURERS ID DATA	36 - 38
SERVICE RECORD	39

HOW TO CONTACT US

Terracore Group Ltd
T/A Dustquip

+44(0) 1454 513 000

Quercus Court
Armstrong Way
Yate
BS37 5NG

www.dustquip.co.uk
info@dustquip.co.uk



SPECIFICATION SHEET

 **JETMISTER**

JM35 MOBILE

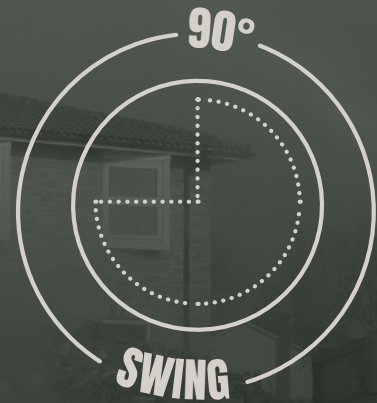

Manoeuvrability

Lifting eyes get the JetMister into difficult areas. Frame can be mounted to water bowser (JMSF) or heavy-duty puncture-proof wheels for site mobility (JM).

Jet nozzle

Push button positioning or auto 45° and 90° swinging nozzle.

Tilting mast

Heavy-duty mast with 0-30° tilt positioning for reaching high areas. Can also be put flat to transport easily.

Easy controls

Simple control operation to start/stop pump and move jet automatically from left to right. Emergency stop and warning signals.

Just add water!

A 1" quick release connector for a suction hose. Just connect bowser/supply and feed with potable water.

Electric, Diesel or Petrol Engine Powered

Quality Engine with electric start or 3 phase Electric Powered direct drive.

Mobility

Locking brake swivel wheel at the back to battle the uneven ground and heavy duty wheels



Easy Remote

Control JetMisters from 100m away.

SPECIFICATION SHEET



Versatility

The JetMister has heavy-duty puncture-proof tyres and braked swivel wheel enabling it to be easily positioned on site.

Dust suppressed

High-pressure mist can be adjusted with engine speed and pressure regulator to perfect the right amount of mist for the job.

Water and space saving

The JetMister is designed to control dust issues with just the right amount of water to avoid unnecessary flooding and saving water. The collapsible mast allows easy transportation and storage, taking up minimal room.

Safety

The JetMister can be positioned in danger zones where you don't want your workers. Replaces the need of operating fire hose or pressure washers for suppressing dust.



PRODUCT SPECIFICATIONS

	JM35-D	JM35-P	JM35-E	JMSF35-D	JMSF35-P	JMSF35-E
Engine / Motor	Diesel Yanmar 7kw	Petrol Vanguard 10. Kw	Electric 7.5. Kw	Diesel Yanmar 7kw	Petrol Vanguard 10. Kw	Electric 7.5. Kw
Dimensions (LxWxH)	1220mm x 870mm x 1230-2190mm 48" x 34" x 48-86"			1120mm x 870mm x 1130-2090mm 44" x 34" x 44-82"		
Weight	250kg / 550lbs	215kg / 473 lbs	250 lbs	250kg / 550lbs	215kg / 473 lbs	250 lbs
Horizontal Oscillation	45° & 90°					
Vertical Tilt	0° - 45°					
Water Consumption	14-40 lpm / 3-9 gpm					
Mist Distance						

INTRODUCTION & GENERAL INFORMATION

INTRODUCTION

Thank you for choosing a Dustquip JetMister

Please take time to carefully read the contents of this manual before you commence using the JetMister. Ensure everyone responsible for its use is fully conversant with the procedures for preparing for use, operating and maintaining the JetMister

By following, understanding and practicing the information and procedures in this manual, your Dustquip JetMister will give you many years of reliable and safe use.

Certain information contained in this manual is governed by law and is subject to review and change without prior notice. Great care however, has been taken to ensure that the information in this manual is correct at time of publication. However, it is the owners/users sole responsibility to ensure that they fully comply with all legal requirements. Terracore Group Ltd cannot and will not accept any liability for any inaccuracy or incorrectly stated legal requirements

GENERAL INFORMATION

The information contained in the Handbook is correct at the time of publication, and can be altered by the manufacturers without prior notice.

The Operator must read this handbook and the motor/engine & pump operators handbook (appended to this document) and be familiar with all controls before operating the equipment.

The contents of this handbook are a guide to the machines control, operation, operating scope and maintenance. It is not a training manual.

These are the original Instructions in the English Language issued by Dustquip.

The Operation Handbook must be stored near the machine in an environment protected against humidity and heat. The handbook must be attached to the machine in the event it is hired or sold. Damaging, modifying or removing part of the manual is prohibited.

WARRANTY CONDITIONS

1. WARRANTY COVERAGE

- All machines manufactured by Terracore Ltd / Dustquip are covered by a warranty for a period of one (1) year or 500 operational hours, whichever comes first, from the date of purchase.
- The warranty covers defects in materials and workmanship under normal use and service
- The warranty does not cover misuse, abuse or neglect.

2. WARRANTY SERVICE

- Warranty service must be performed by authorized Terracore Technicians.
- Customers are responsible for shipping the machine to the factory for warranty service at their own expense
- Dustquip Ltd will cover the cost of repairs or replacements for components covered under warranty

3. EXCLUSIONS

This warranty does not cover damage resulting from

- Misuse, abuse, or neglect
- Unauthorized modifications or repairs
- Failure to follow operating instructions
- Acts of nature, such as floods, fires or frost damage
- Normal wear and tear
- This list is not exhaustive

4. CLAIM PROCESS

- To initiate a warranty claim, customers must:
- Contact Dustquip and request a warranty application form
- On receipt of a completed form, an ISS Number will be issued.
- Ship the machine to the designated Dustquip factory, along with the ISS number clearly marked on the machine
- Dustquip will inspect the machine upon receipt to determine warranty coverage
- If the issue is covered under warranty, repairs will be carried out in a timely manner
- If the issue is deemed to be not covered by warranty a quotation for the repairs will be provided to the customer
- In the case of a Dustquip Technician is required to attend site, an order number will be required from the customer to cover the site call out charge. If the issue is deemed to be covered by warranty, the call out will not be charged.

5. LIMITATION OF LIABILITY

- Terracore Ltd / Dustquip shall not be liable for any incidental or consequential damages arising from the use or inability to use the machine, including but not limited to loss of profits, loss of business or interruption of operations

6. TRANSFERABILITY

- This warranty is not transferable and applies only to the original purchaser of the machine

7. GOVERNING LAW

- This warranty policy shall be governed by and construed in accordance with the laws of your region, without regard to its conflict of law principles

8. MODIFICATION OF TERMS

- Terracore Ltd / Dustquip reserves the right to modify or amend this warranty policy at any time, without notice

9. CONTACT INFORMATION

- For warranty enquiries or assistance please contact Dustquip in your local region. Contact details can be found on page 2 of this document.

10. EXCLUSIVE WARRANTY SERVICE

- Warranty repairs of service will exclusively be carried out at the Dustquip factory in your location. No warranty repairs or service will be provided elsewhere.

By purchasing a machine from Terracore Ltd / Dustquip, you acknowledge that you have read, understood, and agreed to the terms and conditions of this warranty.

Updated March 2025 | Ref WC001

SAFETY RULES



DANGER

Failure to obey the instructions and safety rules in this manual will result in death or serious injury.

Do Not Operate Unless:

You learn and practice the principles of safe machine operation contained in this operators manual.

You read, understand and obey the manufacturer's instructions and safety rules - safety and operators manuals and machine decals, employers safety rules and work site regulations & applicable governmental regulations

You are properly trained to safely operate the machine

1. Avoid hazardous situations. Know and understand the safety rules before going on to the next section
2. Always perform a pre-operation inspection
3. Always perform function tests prior to use
4. Inspect the workplace
5. Only use the machine as it was intended



ELECTROCUTION HAZARDS

This machine is not electrically insulated and will not provide protection from contact with or proximity to electrical current

Do not operate the machine during lightning or storms

Do not use the machine as a ground for welding

Ensure safe routing of power cable to minimise risk of electrocution

SAFETY RULES



EXPLOSION AND FIRE HAZARDS

Do not operate the machine in hazardous locations, or locations where potentially flammable or explosive gases or particles may be present

SETUP HAZARDS

Check work area for obstructions and other possible hazards. The machine discharges water which could cause slip hazards, your RA&MS will need to take this into account

1. Do not use the machine whilst under the influence of alcohol or drugs (prescription or recreational)
2. Ensure machine is sited properly on level stable ground
3. Do not alter or disable machine components that in any way affect the safety and stability
4. Be aware of ground surface prior to installation
5. Do not use the machine on a moving or mobile surface or vehicle
6. Ensure tyres are in good condition
7. Do not ride on machine
8. Do not alter or disable any safety switches or guards
9. Do not operate the machine in strong or gusty winds



BODILY INJURY HAZARDS

Use common sense and planning when positioning and using the machine



Keep hands & limbs away from rotating parts and pinch points

Always wear the correct PPE

COMPONENT DAMAGE HAZARDS

- When using a generator, ensure it is fitted with a voltage regulator before use & is adequately grounded
- Ensure constant water supply to pump. Pump damage will occur if allowed to run dry
- Do not use the machine as a ground for welding

DAMAGED MACHINE HAZARDS

- Do not use a damaged or malfunctioning machine
- Conduct a thorough pre-operation inspection of the machine and test all functions before work shift. Immediately remove from service a damaged or malfunctioning machine & report it to your company manager/hire provider.
- Ensure all maintenance has been carried out as specified in this manual.
- Be sure all decals are in place and legible.

LEGEND

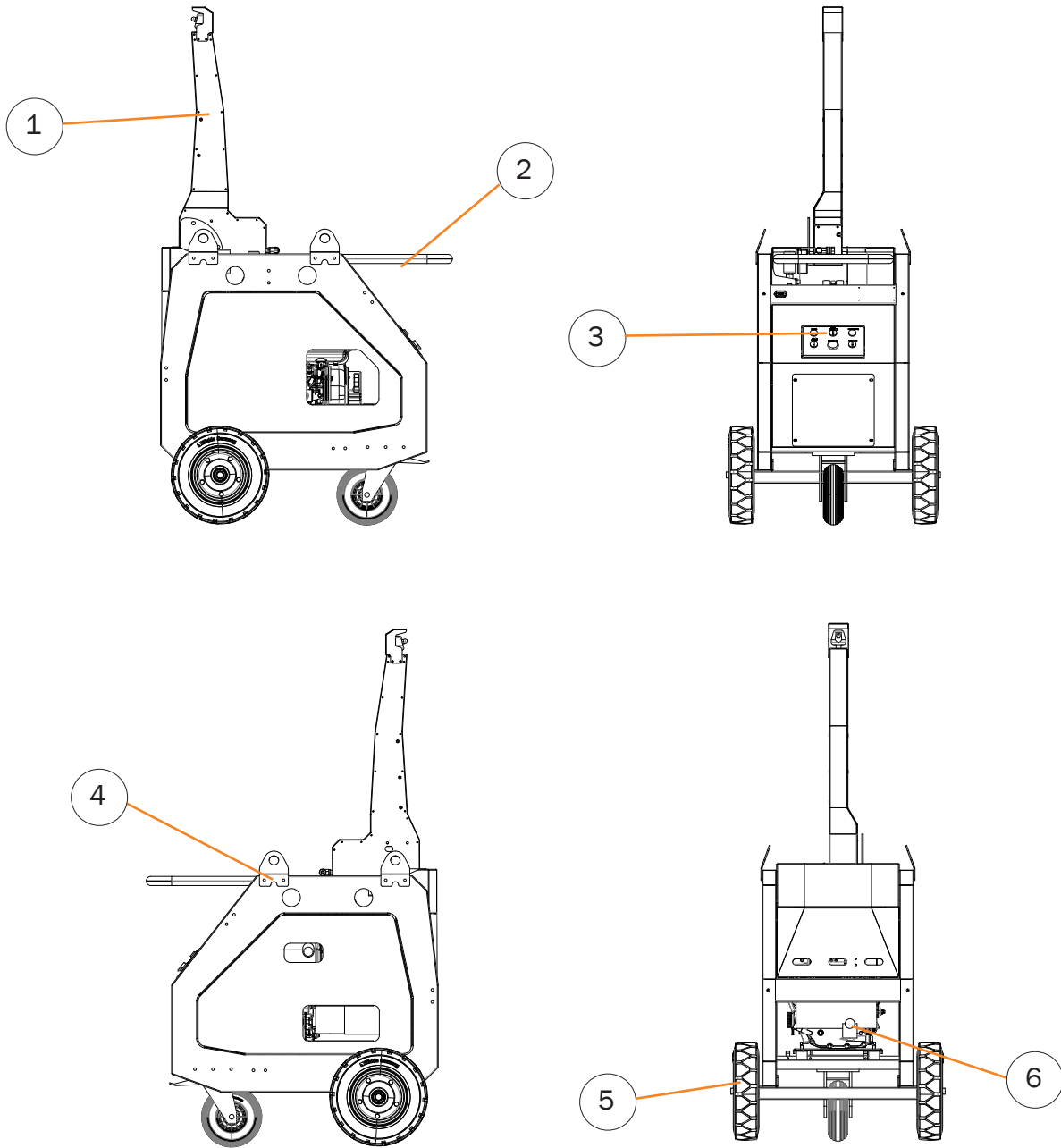

1	Mast & Jet Nozzle
2	Machine Handle
3	Machine Controls
4	Lifting Eyes
5	Wheels
6	Water Inlet

LEGEND (Cont)

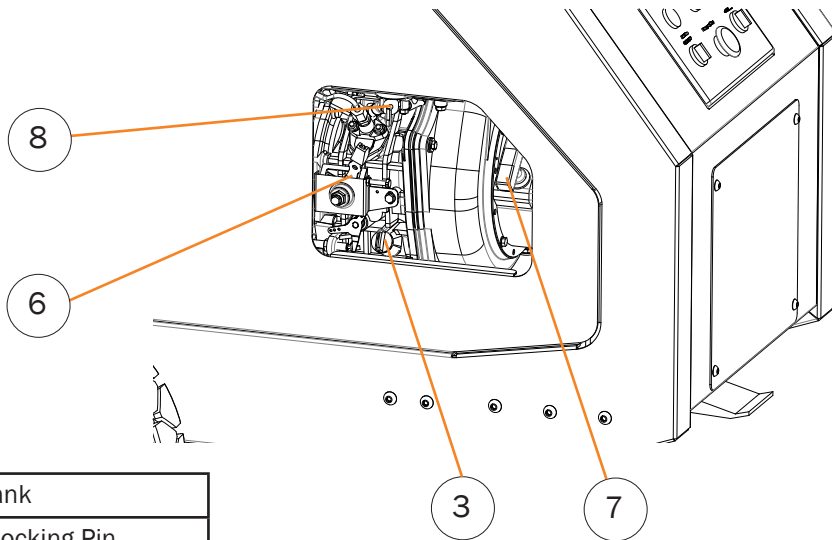
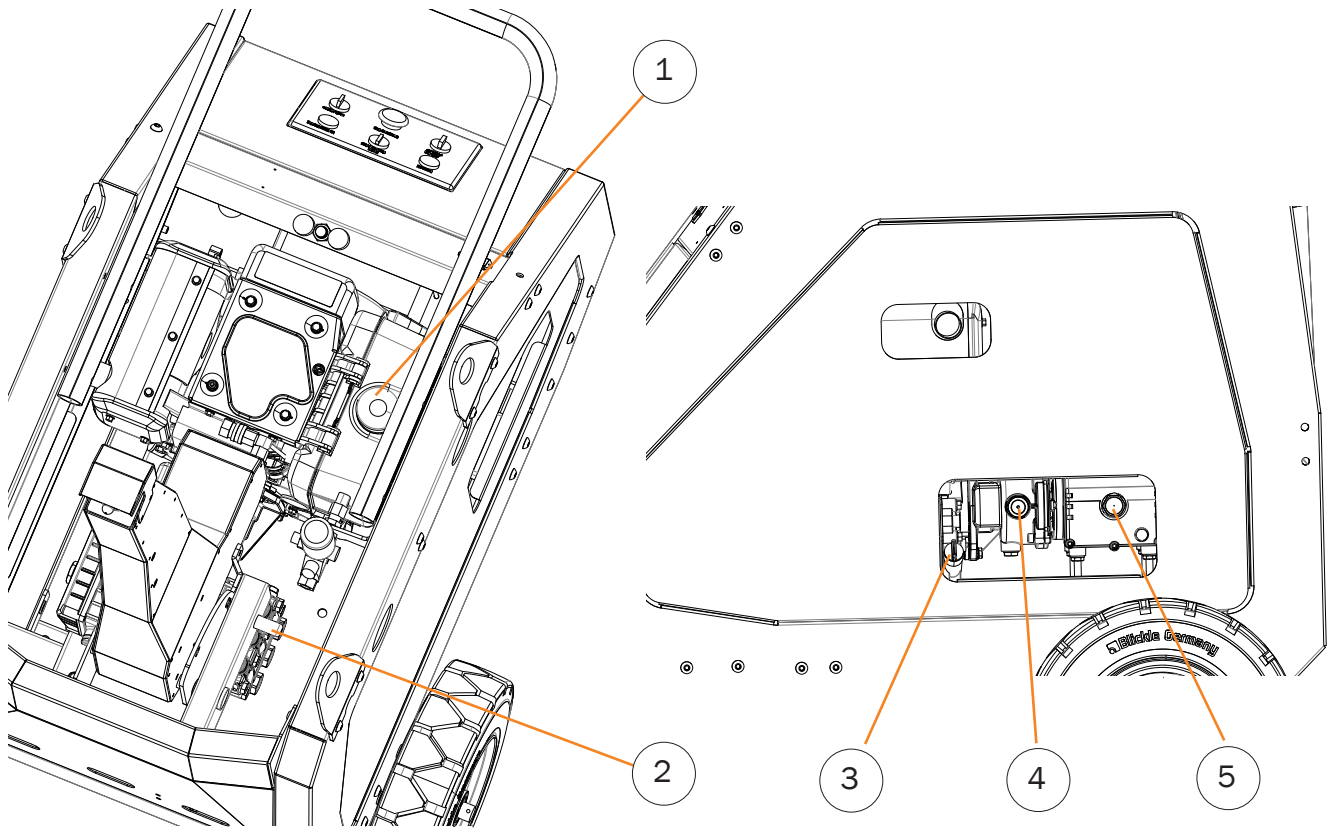

1	Fuel Tank
2	Mast Locking Pin
3	Engine Oil Plug
4	Gearbox Oil Level
5	Pump Oil Level
6	Throttle Lever
7	Recoil Start Handle
8	Fuel Switch

DECALS

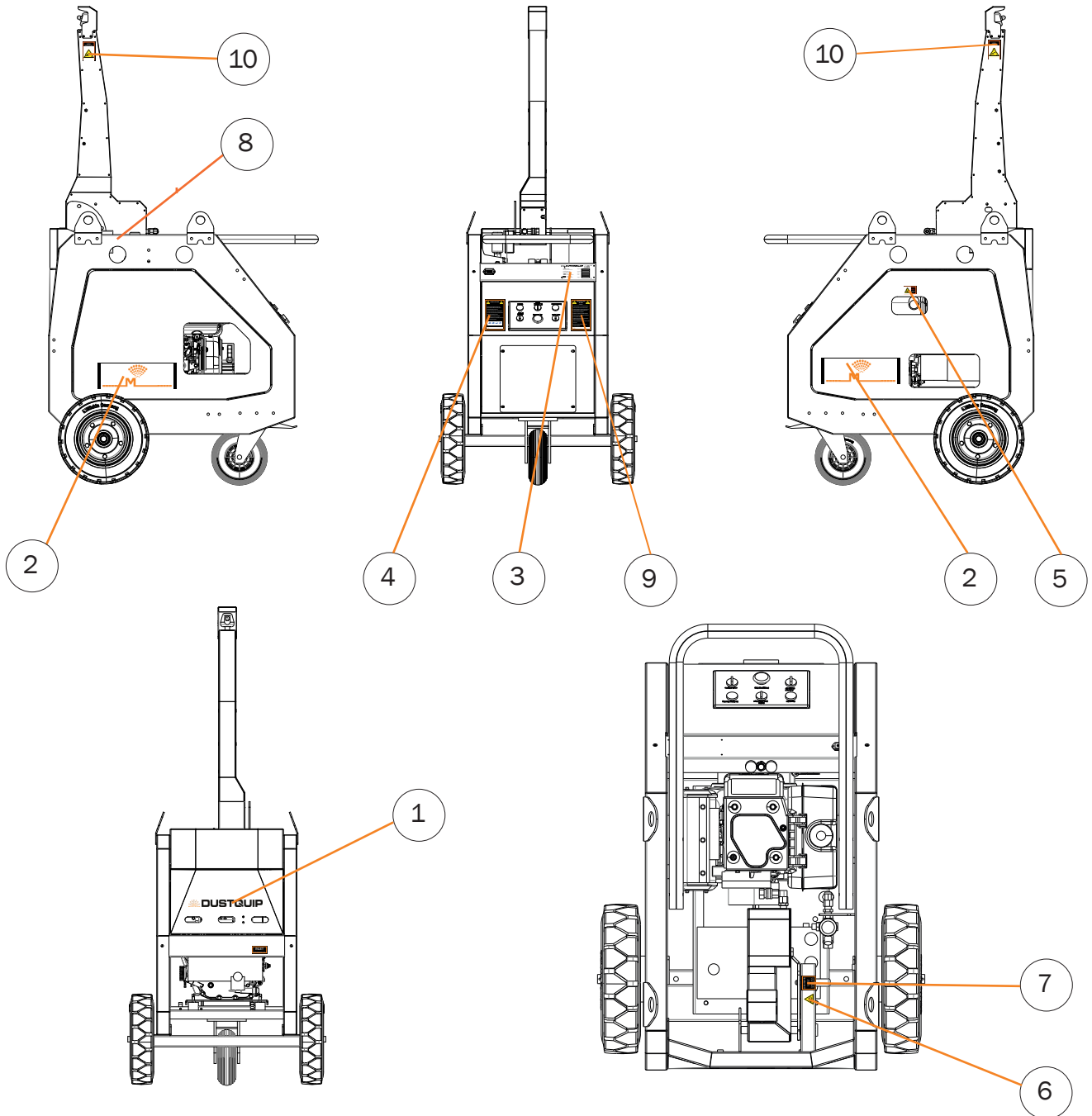

1	Dustquip Decal
2	JetMister Decal
3	Serial Plate
4	Safe Use Decal
5	Hot Exhaust

6	Water Inlet Decal
7	Pinch Point
8	Locking Pin Decal
9	Operation Decal
10	Eye Protection & Trap Hazard Decal

CONTROLS

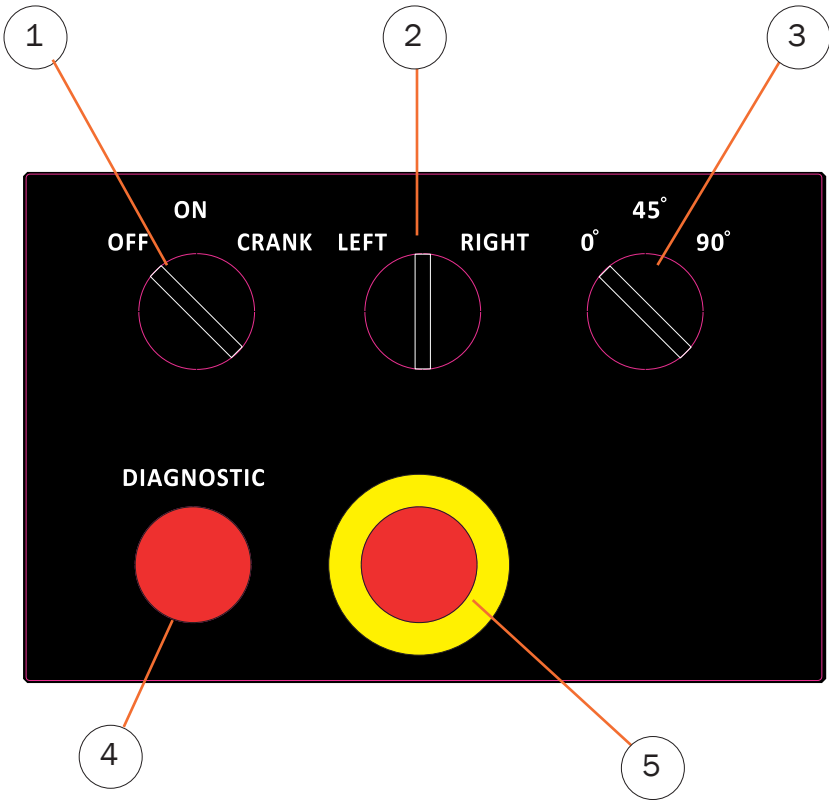

1	Main On/Off/Crank Switch
2	Left/Right Slew Position Switch
3	45/90 Deg Auto Slew Switch
4	Diagnostic Light
5	E Stop Switch
6	Rotate Mast Left (Manual)
7	Mast Stop Oscillate
8	Mast Oscillate 90 Deg
9	Power On Remote Button
10	Rotate Mast Right (Manual)
11	Mast Oscillator 45 Deg
12	Start Engine
13	Turn Off Remote & Machine

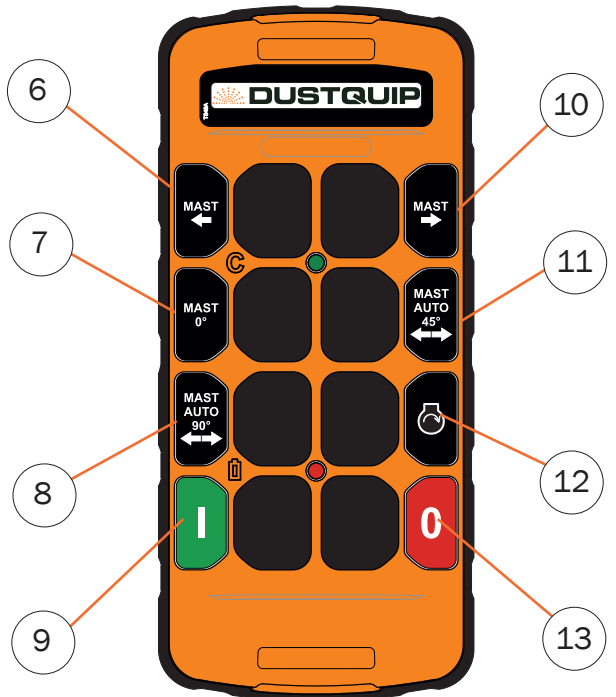

PRE-OPERATION INSPECTION



DANGER

DO NOT OPERATE UNLESS:

You learn and practice the principles of safe machine operation contained in this operators manual.

1. Avoid hazardous situations
2. Always perform a pre-operation inspection. Know and understand the pre-operation inspection before going on to the next section
3. Always perform function tests prior to use
4. Inspect the workplace
5. Only use the machine as it was intended

FUNDAMENTALS

It is the responsibility of the operator to perform a pre-operation inspection and routine maintenance

The pre-operation inspection is a visual inspection performed by the operator prior to each work shift

The inspection is designed to discover if anything is apparently wrong with a machine before the operator performs the function tests

The pre-operation inspection also serves to determine if routine maintenance procedures are required. Only routine maintenance items specified in this manual may be performed by the operator.

Refer to the list on the next page and check each of the items and locations for modifications, damage or loose/missing parts.

A damaged or modified machine must never be used. If damage or variation from factory delivered condition is discovered, the machine must be tagged and removed from service

Repairs to the machine may only be made by a qualified service technician according to the manufacturers specifications. After repairs are completed, the operator must perform a pre-operation inspection again before going on to the function tests

Scheduled maintenance inspections shall be performed by qualified service technicians, according to the manufacturers specifications.

PRE-OPERATION INSPECTION

- Be sure that all decals are legible and in place. See “*Decals*” section
- Be sure the fuel tank is full of fuel, oil levels are correct and the mast locking pin secures the mast in place
- Ensure all guards are in place
- Be sure the correct accessories & manual is present. See parts list
- Check the following components or areas for damage, modifications and improperly installed or missing parts

-
1. Electrical components
 2. Wiring
 3. Battery, terminals tight & not damaged
 4. Engine oil level
 5. Gear box oil level
 6. Pump oil level
 7. Fluid leaks
 8. Fuel level
 9. Fuel leaks
 10. Wheels & tyres
 11. Park brake
 12. Safety interlocks

Check entire machine for:

1. Cracks in welds or structural components
2. Dents or damage to the machine
3. Be sure that all structural and other critical components are present and all associated fasteners are in place and properly tightened

MAINTENANCE

MAINTENANCE SYMBOLS LEGEND:

NOTICE

The following symbols have been used in this manual to help communicate the intent of the instructions. When one or more of the symbols appear at the beginning of a maintenance procedure, it conveys the meaning below



OBSERVE AND OBEY:

Only routine maintenance items specified in this manual shall be performed by the operator.

Scheduled maintenance inspections shall be completed by qualified service technicians, according to the manufacturers specifications and the requirements specified in the responsibilities manual



BURN HAZARD:

Keep your hands and other body parts away from hot engine surfaces such as the muffler, exhaust pipe and engine block during operation and shortly after you shut the engine down. These surfaces are extremely hot while the engine is operating and could seriously burn you

Failure to comply could result in death or serious injury.



Indicates tools will be needed to carry out



HIGH-PRESSURE HAZARD:

- Avoid skin contact with high pressure diesel fuel spray caused by a fuel system leak such as a broken fuel injection line. High pressure fuel can penetrate your skin and result in serious injury. If you are exposed to high pressure fuel spray, obtain prompt medical treatment.
- Never check for a fuel leak with your hands. Always use a piece of wood or cardboard. Have your authorized dealer or manufacturer repair the damage
- Failure to comply could result in death or serious injury.

MAINTENANCE



FIRE AND EXPLOSION HAZARD:

- Diesel fuel is extremely flammable and explosive under certain circumstances.
 - Only fill the fuel tank with diesel fuel. Filling the fuel tank with petrol or gasoline may result in a fire
-
- Never refuel with the engine running.
 - Wipe up all spills immediately
 - Keep sparks, open flames or any other form of ignition (match, cigarette, static electricity source) away when fuelling/refuelling
 - Never overfill the fuel tank
 - Fill the fuel tank and store fuel in well ventilated place only
 - Be sure to place the diesel fuel container on the ground when transferring the diesel fuel from the pump to container. Hold the hose nozzle firmly against the side of the container while filling it. This prevents static electricity build-up which could cause sparks and ignite fuel vapours
 - Never place diesel fuel or other flammable material such as oil, hay or dried grass close to the engine during engine operation or shortly after operation.
 - Before you operate the engine, check for fuel leaks. Replace rubberized fuel hoses every 2 years or every 2000 hours of engine operation, whichever comes first.
 - Do not let fuel level exceed the fuel level mark on the fuel filter (inlet) of the fuel tank filler port. The fuel may expand when the ambient temperature is high, and overflowing the fuel cap
 - Failure to comply will result in death or serious injury.

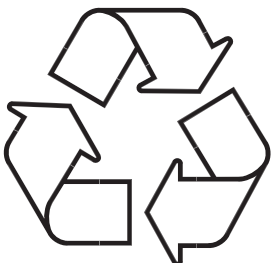

ENVIRONMENTAL RESPONSIBILITY:

- Be environmentally responsible. Follow these procedures along with your environmental policy for hazardous waste disposal. Failure to follow these procedures may seriously harm the environment.
- Follow the guide lines of the relevant environmental department in your country (EPA in USA and EA in UK etc) for the proper disposal of hazardous materials such as engine oil, diesel fuel and engine coolant. This includes used filters. Consult the local authorities or reclamation facility
- Never dispose of hazardous materials irresponsibly by dumping them into a sewer, on the ground or into ground water or waterways

MAINTENANCE

INLET FILTER CHECKING & CLEANING

NOTICE

CHECK FILTER WITH WATER SUPPLY TURNED OFF AND DISCONNECTED & ENGINE OFF

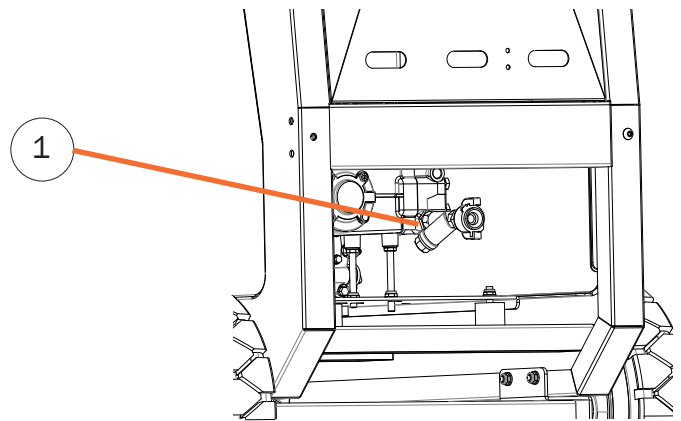

Maintaining a clean inlet (1) filter is essential to good machine performance. Operating the machine with a clogged inlet filter will result in degraded performance and could damage the pump

Tools Required:

- Adjustable spanner
1. Loosen the Y strainer access plug using a suitable spanner
 2. Carefully unwind the plug and withdraw the filter gauze from filter body
 3. Clean gauze with clean water
 4. Insert the gauze back into the filter body, screw in the access plug ensuring the gasket is in place and in good condition
 5. Tighten access plug

MAINTENANCE

CHECK PUMP OIL LEVEL

NOTICE

CHECK OIL WITH WATER TURNED OFF AND DISCONNECTED & ENGINE OFF



Ensuring the pump has the correct oil level is essential to prevent possible pump damage.

- The oil level can be observed through the sight glass (1).
- The level can be topped up via the oil port (2).
- The correct oil level is approx halfway up the sight glass.

1. Check oil level and condition via the sight glass (1).
2. If oil is required, remove the vent plug by twisting anti-clockwise until it is free of the pump housing
3. Pour the correct grade oil into the pump until the level reaches approx half way up the sight glass
4. Refit vent plug & tighten

OIL APPEARANCE

Should the oil take on a milky appearance please contact your Dustquip repair centre. This could indicate internal pump seal failure & water contamination. The machine must be taken out of service until the pump has been inspected & repaired if necessary.

If the oil has taken on a dark brown/black appearance an oil change is recommended. Oil discolouration will occur during normal operation - this is to be expected

The oil should have a bright clear golden appearance.

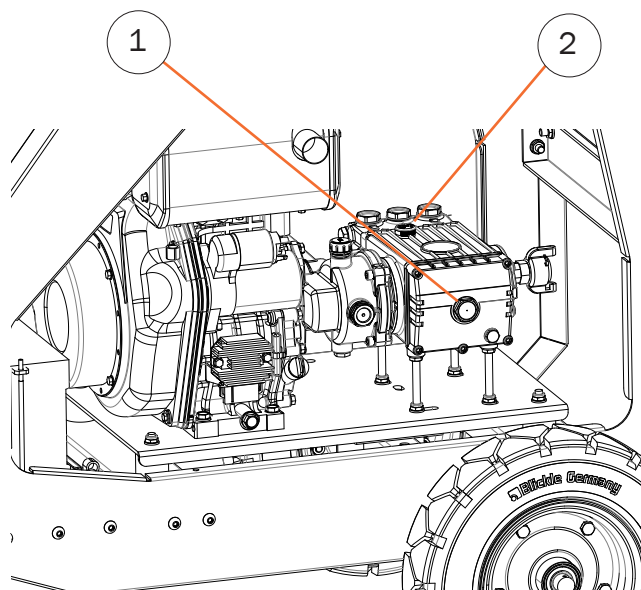

Side panel removed for better visibility - panel removal not necessary for checking & topping up levels

MAINTENANCE

CHECK GEARBOX OIL LEVEL

NOTICE

CHECK OIL WITH WATER TURNED OFF AND DISCONNECTED & ENGINE OFF



Ensuring the gearbox has the correct oil level is essential to prevent possible gearbox damage.

- The oil level can be observed through the sight glass (1).
- The level can be topped up via the oil port (2).
- The correct oil level is approx half way up the sight glass.
- The correct oil grade can be found in the specifications section of this manual

Tools Required:

- None
1. Check oil level and condition via the sight glass (1).
 2. If oil is required, remove the vent plug by twisting anti-clockwise until it is free of the pump housing
 3. Pour the correct grade oil into the pump until the level reaches approx half way up the sight glass
 4. Refit vent plug & tighten

OIL APPEARANCE

Should the oil take on a milky appearance please contact your Dustquip repair centre. This could indicate internal seal failure & water contamination. The machine must be taken out of service until the machine has been inspected & repaired if necessary.

If the oil has taken on a dark brown/black appearance an oil change is recommended. Oil discolouration will occur during normal operation - this is to be expected

The oil should have a bright clear golden appearance.

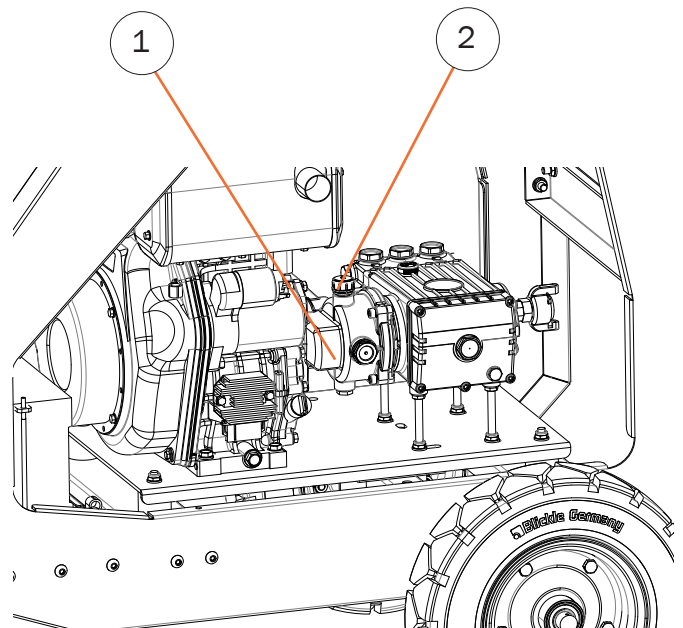

Side panel removed for better visibility - panel removal not necessary for checking & topping up levels

MAINTENANCE

CHECK ENGINE OIL LEVEL



Ensuring the engine has the correct oil level is essential to prevent possible engine damage. The oil level can be observed by removing the oil cap.

Checking Engine Oil

1. Ensure the engine is level
2. Remove oil cap/dipstick (1) from either location and wipe with a clean cloth
3. Fully reinsert the oil/cap (*Do not screw in*)
4. Remove oil cap/dipstick. The oil level should be between upper (2) and lower (3) lines on the oil cap/dipstick
5. Fully reinsert the oil cap/dipstick and hand tighten. Over-tightening the oil cap/dipstick will damage it

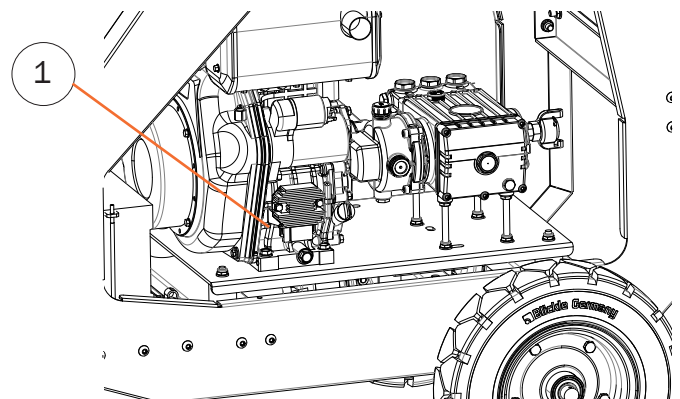

Side panel removed for better visibility - panel removal not necessary for checking

The correct oil grade can be found in the specifications section of this manual

Adding Engine Oil

1. Ensure the engine is level
2. Remove oil cap/dipstick (1)
3. Add indicated amount of engine oil at either one of the engine oil filler ports (4)
4. Wait one minute and check oil level
5. Add more oil if necessary
6. Fully reinsert the oil cap/dipstick (1) and hand tighten. Over-tightening the oil cap/dipstick will damage it

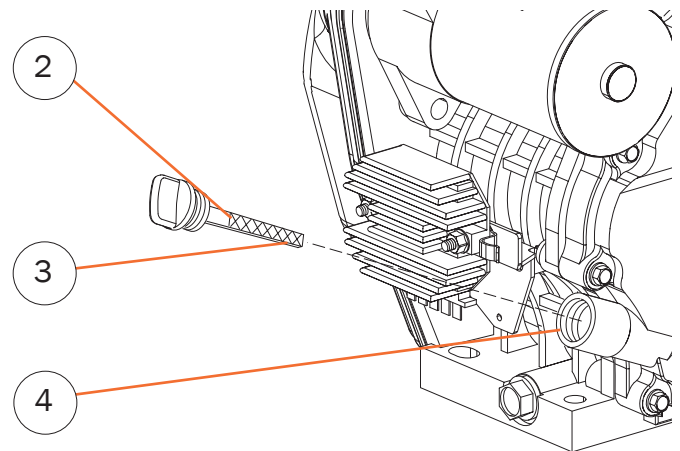

NOTE

- Only use the engine oil grade specified. Other grades may cause internal engine damage
- Prevent dirt and debris from contaminating the engine oil
- Never mix different types of engine oil. This could cause internal engine damage
- Never overfill. Overfilling may result in white exhaust smoke, engine over-speed or internal damage

MAINTENANCE

DRAINING THE OIL



NOTICE

CHANGE OIL WITH THE ENGINE OFF. ENGINE WILL BE HOT

Drain the engine oil as follows:

1. Make sure the engine is level
2. Start the engine and bring it up to operating temperature
3. Stop the engine
4. Remove the oil cap/dipstick (1) to allow the engine oil to drain more easily
5. Position a container under the engine to collect waste oil
6. Remove the drain plug located on the bottom of the cylinder block (4). Allow oil to drain
7. After all oil has been drained from the engine, install the drain plug (4) and tighten to 19.6 - 23.5 NM
8. Dispose of oil properly

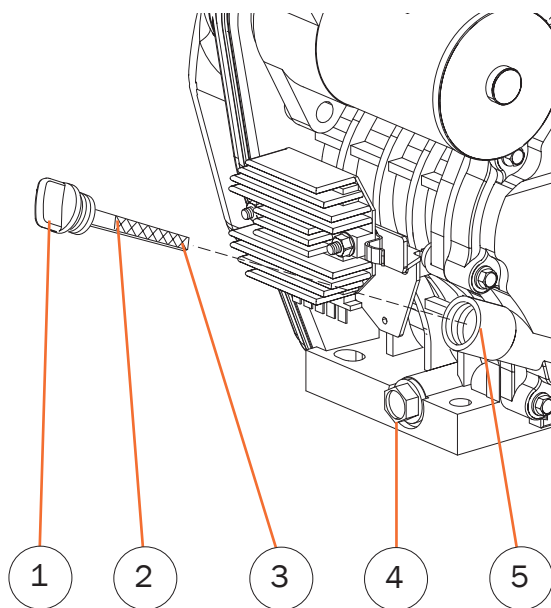

MAINTENANCE

REPLACE ENGINE OIL FILTER

NOTE

- Never overfill the engine with engine oil
- Always keep the oil level between the upper and lower lines on the oil cap/dipstick

Replace the engine oil filter as follows:

1. Remove the oil filter retaining bolt (8)
2. Pull the oil filter cap (7) out and remove the oil filter (6).
3. Install the new oil filter (7)
4. Make sure the oil filter cap is fully seated (2)
5. Install and tighten the oil filter retaining bolt (8)
6. Add new engine oil as specified in *Adding Engine Oil* on page 19
7. Warm up the engine by running it for 5 minutes and check for any engine oil leaks
8. After engine is warm, shut it off and let it sit for 10 minutes.
9. Re-check oil level & top up if required

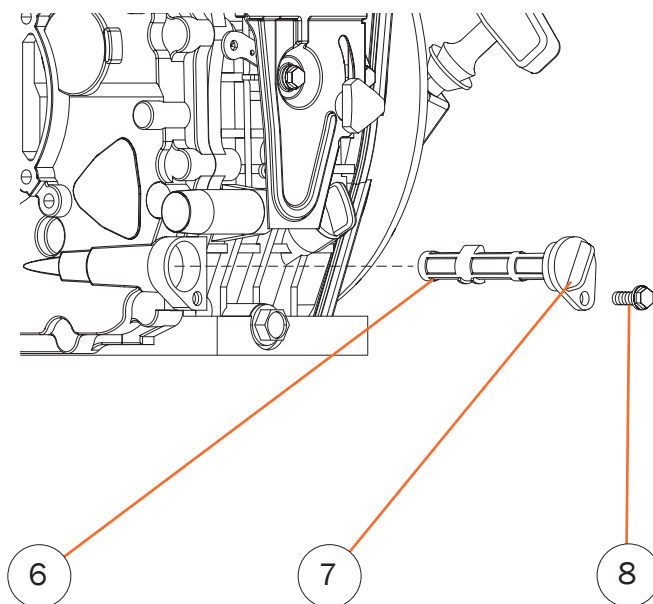

ENGINE SERVICE INTERVALS:

Please refer to the Yanmar Engine Manual for service intervals & detailed maintenance instructions. A copy of the Yanmar Engine Manual is supplied with the machine

Basic points are covered in this manual. Please use this manual in conjunction with the Yanmar Engine Manual

Statutory regulations and requirements are also contained in the Yanmar Engine Manual

FUNCTION TESTS



DO NOT USE UNLESS:

You learn and practice the principles of safe machine operation contained in this operators manual.

1. Avoid hazardous situations
 2. Always perform function tests prior to operation. Know and understand the function tests before going on to the next section
 3. Always perform function tests prior to use
 4. Inspect the workplace
 5. Only use the machine as it was intended
-

FUNDAMENTALS:

The function tests are designed to discover any malfunctions before the machine is put into service

The operator must follow the step by step instructions to test all machine functions

A malfunctioning machine must never be used. If malfunctions are discovered, the machine must be tagged and removed from service

Repairs to the machine may only be made by a qualified service technician, according to the manufacturers specifications

After repairs are completed, the operator must perform a pre-operation inspection and function tests again before putting the machine into service

FUNCTION TESTS:

Select an area that is firm, level and free of obstructions

1. Ensure a water supply is connected to the inlet and turned off
2. Check the fuel tank is full of fuel

FUNCTION TESTS

AT THE CONTROLS:

1. Ensure the e-stop button is not pressed in and the mast is stowed
2. Turn the power switch to the “ON” position, the Diagnostic lamp should rapidly flash
3. Turn the centre switch to the “Left” and hold, the nozzle will turn to the left. Release the switch and the nozzle will stop. Ensure the nozzle moves all the way to the left
4. Turn the centre switch to the “Right”, the nozzle will then turn to the right. Release the switch and the nozzle will stop. Ensure the nozzle moves all the way to the right
5. Turn the right switch to “45” the nozzle will cycle left to right through 45 degrees.
6. Turn the right switch to “90” the nozzle will cycle left to right through 90 degrees.
7. Set the right switch back to “0”
8. Turn the power switch to “Crank” - the engine will not try and start.
9. Ensure fuel is turned on, lift the mast and start the engine.
10. With the water turned off, the engine will run for approx 10 seconds and shut down
11. Check the “Diagnostic” lamp flashes slowly
12. Turn on water supply
13. Turn the power switch to “Off” and then back to “On” to reset the controller
14. Ensure the area where water will be discharged is clear
15. Turn the power switch to “Crank” and start the engine
16. Check the nozzle is discharging correctly & no leaks from pipe work
17. Turn engine off, check for pipe work leaks, oil leaks & fuel leaks.
18. Check all fixings are tight & secure

If the machine fails any of these function tests, it should be removed from service and repaired

WORKPLACE INSPECTION



DO NOT USE UNLESS:

You learn and practice the principles of safe machine operation contained in this operators manual.

1. Avoid hazardous situations
2. Always perform function tests prior to operation
3. Inspect the workplace. Know and understand the function tests before going on to the next stage
4. Only use the machine as it was intended

FUNDAMENTALS:

The workplace inspection helps the operator determine if the workplace is suitable for safe machine operation. It should be performed by the operator prior to moving the machine to the workplace

It is the operators responsibility to read and remember the workplace hazards, then watch for and avoid them while moving, setting up and operating the machine.

WORKPLACE INSPECTION:

Be aware of and avoid the following hazardous situations

1. Bumps, floor obstructions or debris
2. Slopes
3. Unstable or slippery surfaces
4. Overhead obstructions
5. Hazardous locations
6. Inadequate surface support to withstand all load forces imposed by the machine
7. Wind and weather conditions
8. The presence of unauthorised personnel
9. Low temperature & freezing conditions
10. Other possible unsafe conditions
11. Ensure any equipment or objects that could be damaged by water are removed from the area

OPERATING INSTRUCTIONS

FUNDAMENTALS:

The Operating Instructions section provides instructions for each aspect of machine operation. It is the operators responsibility to follow all the safety rules and instructions in the operators, safety and responsibilities manuals

This Jet Mister is designed to provide water assisted dust suppression for a wide range of dust types. Only clean tap water must be used - please refer to the Legionella section for further information.

Care must be taken when positioning the machine that the water mist generated by the machine does not cause any unintended damage. Dustquip cannot be held responsible for any damage caused.

Only trained and authorized personnel should be permitted to operate a machine. If more than one operator is expected to use a machine at different times in the same work shift, they must be qualified operators and are all expected to follow all safety rules and instructions in the operators safety and responsibilities manuals. This means every new operator should perform a pre-operation inspection, function tests , and a workplace inspection before using the machine.

MOVING THE MACHINE

1. Before moving the machine, plan your route. Ensure there are not obstacles on your route. Ensure you have adequate man power to complete the set tasks.
2. To move the unit, release the park brake on the front wheel (1), use the handles to move the machine into the desired location
3. Once the machine is in the desired location, ensure the front of the machine is pointing in the intended direction and apply the park brake (1)

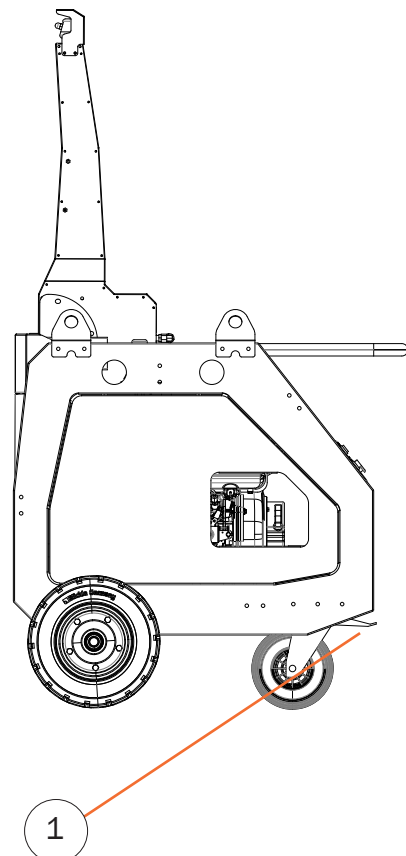

OPERATING INSTRUCTIONS

CONNECTING WATER SUPPLY

1. Connect the water to the inlet connection (A) and turn on supply
2. Check that the water feed pressure **does not exceed 3.5 bar (50 psi)**
3. Ensure the throttle is set to half and the fuel tap is open

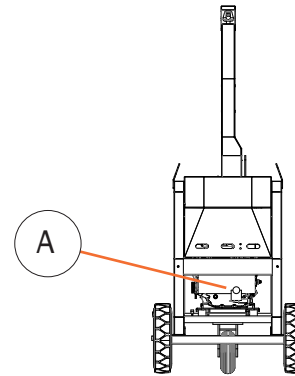

POSITIONING THE MAST

To lift the mast to the required discharge angle:

1. Pull out the Mast Locking Pin (B) and at the same time lift the mast into the upright position, once at the required angle release the locking pin, carefully move the mast forwards until the pin "Clicks" into place. The mast is now locked in the upright position
2. To adjust the angle, pull out the pin and re-locate the mast & release the pin to lock (as above)

NOTE, never adjust the mast while the engine is running - serious injury/death could occur

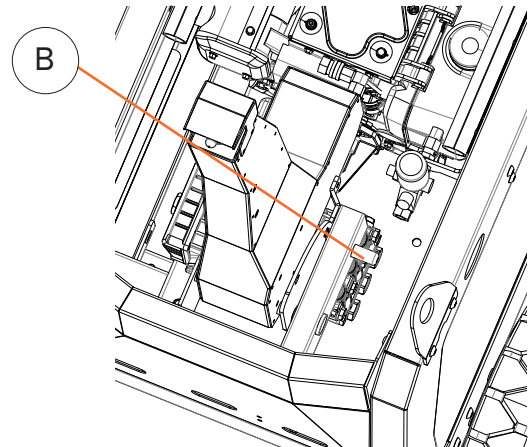

STARTING THE MACHINE

To Start the machine

1. Ensure the e-stop button is not depressed (5), the mast is up, throttle is set to half, tank is full of fuel, and the fuel tap is on and auto oscillation is set to "0" (3)
2. Turn the power switch (1) to the "ON" position
3. The diagnostic lamp (4) will flash rapidly for a few seconds then go solid red. This indicates the engine is ready to be started
4. Turn the power switch (1) to crank and hold in position until the engine has started.

NOTE, never try to crank the engine for more than 15 seconds

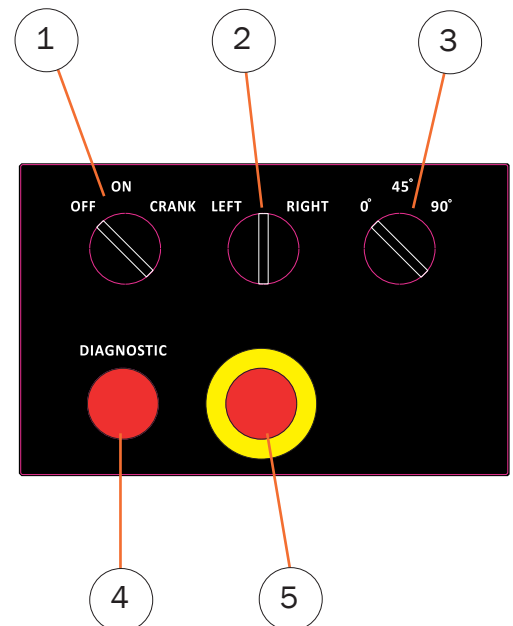

OPERATING INSTRUCTIONS

LOW WATER SHUTDOWN

The machine is equipped with a no water shut down feature, if the machine shuts down on first start follow the below procedure:

1. Set power switch (1) to off and back to on
2. Crank engine to restart & release switch
3. Should the engine shut down again repeat steps 1-2.
4. If the engine repeatedly shuts down check water supply has sufficient pressure (3.5 bar) & flow rate

OSCILLATION CONTROL

Setting the Auto Oscillation.

1. Ensure the engine is running
2. For 45 degree cycle, set switch (3) to 45. The nozzle will cycle from left to right in a 45 degree arc
3. For 90 degree cycle, set switch (3) to 90. The nozzle will cycle from left to right in a 90 degree arc

For Manual nozzle control.

4. Ensure the engine is running & oscillation switch (3) is set to "0"
5. To move the nozzle to the left, hold switch (2) to the left, release switch when nozzle is in the desired location
6. To move the nozzle to the right, hold switch (2) to the right, release switch when nozzle is in the desired location

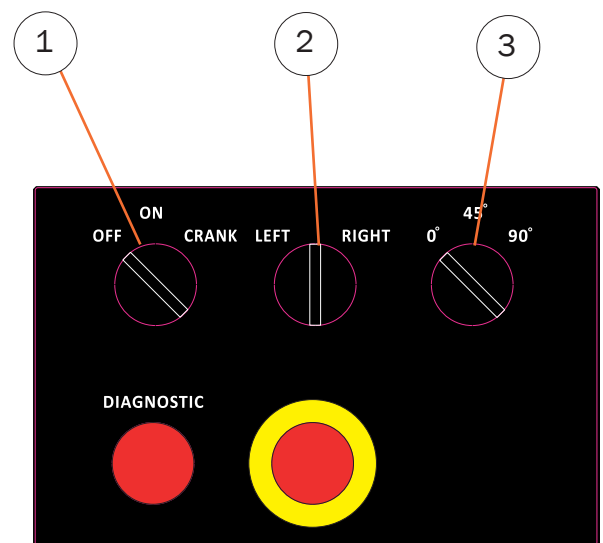

STOPPING THE MACHINE

1. Turn switch (3) to off, engine will stop
2. Turn off fuel switch
3. Turn off water & disconnect supply
4. Stow mast away

COLD WEATHER PRECAUTIONS.

NOTE, exposure to low temperatures will cause serious internal damage, the following steps must be carried out to prevent damage

1. Disconnect water supply & drain pipe work of residual water
2. Fill pipe work & pump with suitable anti-freeze
3. Ensure power is turned off

OPERATING INSTRUCTIONS

USING REMOTE CONTROL

To Start the machine (From the Remote Control)

1. Ensure the e-stop button is not depressed (5), the mast is up, throttle is set to half, tank is full of fuel, and the fuel tap is on and auto oscillation is set to "0" (3)
2. Turn the power switch (1) to the "ON" position
3. The diagnostic lamp (4) will flash rapidly for a few seconds then go solid red. This indicates the engine is ready to be started
4. Press the green power button on the remote control handset (9). The green connected indicator will now rapidly flash (9).
5. Press and hold the Crank button (12), release once the engine has started

NOTE, never try to crank the engine for more than 15

1	Main On/Off/Crank Switch
2	Left/Right Slew Position Switch
3	45/90 Deg Auto Slew Switch
4	Diagnostic Light
5	E Stop Switch
REMOTE	
6	Rotate Mast Left (Manual)
7	Mast Stop Oscillate
8	Mast Oscillate 90 Deg
9	Power On Remote Button
10	Rotate Mast Right (Manual)
11	Mast Oscillator 45 Deg
12	Start Engine
13	Turn Off Remote & Machine

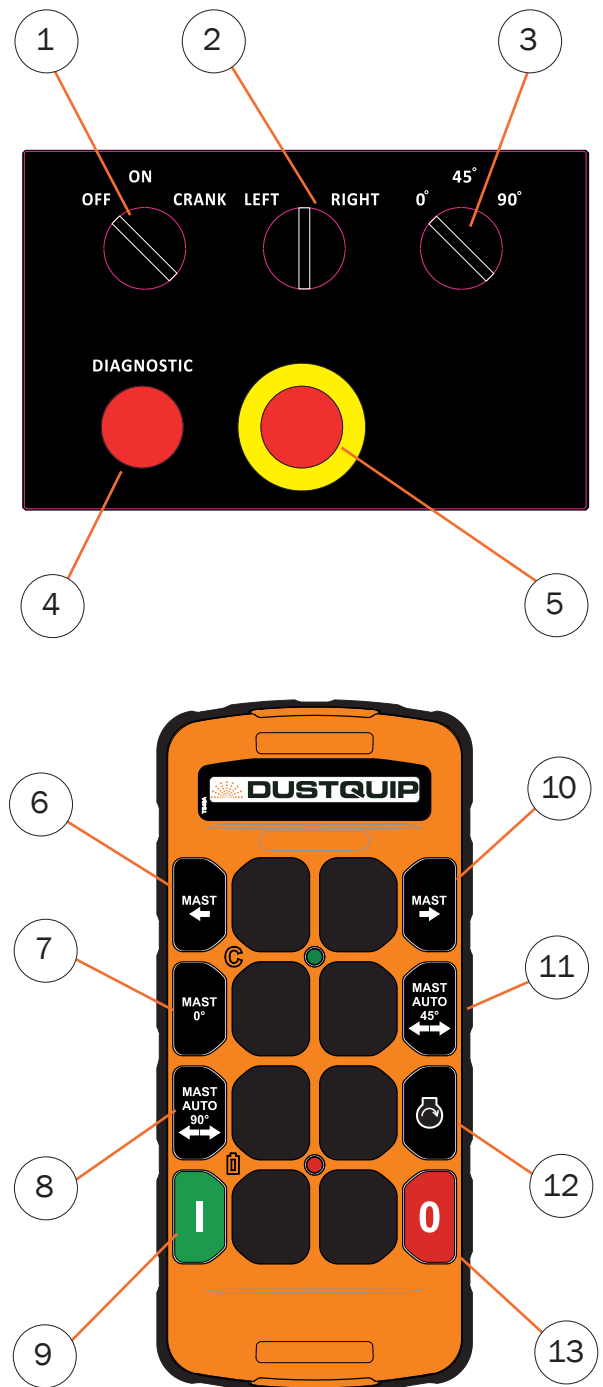

STOPPING THE MACHINE

1. Turn switch (1) to off, engine will stop (on the control panel)
2. Press the red stop button (13) on the remote control, engine will stop. (NOTE - control panel remains on - ensure power switch is set to the off position. Failure to do so will cause a depleted battery)
3. Turn off fuel switch
4. Turn off water & disconnect supply

TRANSPORT INSTRUCTIONS



OBSERVE AND OBEY:

Common sense and planning must be applied to control the movement of the machine when moving it with a forklift

The transport vehicle must be parked on a level surface

SECURING TO TRUCK OR TRAILER FOR TRANSIT:

Always check the machine is on a level surface with both wheels and both feet are in contact with the surface

Inspect the entire machine for loose or unsecured items

Ensure power cable is secured and placed within the machine

TIE DOWN & STRAPPING:

Only use the lifting eyes for strapping.

DO NOT OVER TIGHTEN STRAPS:

Excessive tension of the straps will cause damage to the machine

SPECIFICATIONS

JM35	
Mist Distance M (Ft) (no wind)	25-30 M (80-100 Ft)
Surface coverage M ² (ft ²)	500 M ² (5300 ft ²)
Water Consumption Lpm (gpm)	25-40 Lpm (110 - 178 gpm)
Applications Indoor	Wood chip wetting and stone ballast dust suppression
Applications Outdoor	Demolition, stone ballast dust suppression
Average Water Droplet Size μ	180 micron

	JM35-D	JM35-E
Engine / Voltage / Frequency	Diesel Yanmar	415V 50Hz
Current Consumption	N/A	13 Amps
Power Connection	N/A	16 A CEEFORM
Pump Motor Kw	10	7.5
Dimensions mm (inch)	1220 L x 870 W x 1230-2190 H (48"x34"x48-86")	
Weight Kg (Lbs)	250 KG (550 Lbs)	
Number of Nozzles	1	
Pump Motor Kw	10Kw	
Vertical Tilt Angle	0° - +45°	
Oscillation	45° - 90°	
Water Supply Connection	3/4" Claw Coupling	
Required Water Pressure / min flow	2-5 bar / 40 Lpm	
Water quality	Potable / Filtered	
Operating Temperature	+2°C - 50°C	

Required Oils		
Component	Specification	Volume Required
Gear Box (if fitted)	SAE90 Gear Oil	0.35l
Pump	SAE 10W40	1.2l
Engine (Yanmar)	SAE 15W40	1.6l

Fuel Specifications (Diesel)*	
Location	
USA	No. 2-D, No. 1-D, ASTM D975
EU	EN590 (2009)
International	ISO 8217 DMX
UK	ISO 8217-A1 or A2

* See following page for Bio-Fuel & HVO specifications

BIO-DIESEL FUELS

BIO-DIESEL FUELS:

In Europe and in the United States, as well as some other countries, non-mineral oil based fuel resources such as RME (Rapeseed Methyl Ester) and SOME (Soybean Methyl Ester), collectively known as FAME (Fatty Acid Methyl Esters), are being used as extenders for mineral oil derived diesel fuels.

Yanmar approves the use of bio-diesel fuels that do not exceed a blend of 7% (by volume) of FAME with 93% (by volume) of approved mineral oil derived diesel fuel. Such bio-diesel fuels are known in the marketplace as B7 diesel fuels.

B7 DIESEL FUELS MUST MEET CERTAIN REQUIREMENTS:

The Bio-fuels must meet the minimum specifications for the country in which they are used

- In Europe & UK, bio-diesel fuels must comply with the European Standard EN14214
- In the USA, bio-diesel fuels must comply with the American Standard ASTM D-6751.

RENEWABLE FUEL OR ALTERNATIVE FUELS:

Any renewable or alternative diesel fuel such as HVO (hydrotreated vegetable oil), BTL (biomass to liquid) or GTL (gas to liquid) are permitted.

Alternative fuels must confirm to UK & EU standard EN15940 or USA ASTM D975.

NOTE, engine performance due to fuel properties is not covered by the warranty

MORE INFORMATION:

Please refer to the engine specific handbook supplied with this manual.

Alternatively please contact the Terracore Group or your local Dustquip dealer

LEGIONELLA HEALTH RISK



DANGER

WATER MISTING CAN CAUSE LEGIONELLA DISEASE:

One of the main health risks from contamination in engineering water systems is the bacterial infection Legionella.

This bacterium can be transmitted through water vapour or mist and inhaled, hence leading to respiratory infections.

The more severe cases are from Legionnaires disease, which can lead to symptoms of pneumonia and other secondary infections, in its worst case can lead to death.

The milder forms are Pontiac Fever and Lochgilhead fever.

If you develop symptoms of Flu/Pneumonia after operating this machine seek urgent medical attention.

Legionella Microorganisms flourish in water temperatures of between 22°C and 45°C (71.6 - 113F), particularly, if an abundance of nutrients such as sludge, sediment or rust reside in the water system.

YOU MUST ENSURE:





- Drain system and supply tanks when not in use
- Only use drinking water supply
- Follow a Legionella risk assessment that meets the requirements of the local water authority regulations
- Follow regular tank/system cleaning procedures using disinfectant and/or steam.

MANUFACTURERS IDENTIFICATION DATA

Manufacturer	Terracore Group Ltd
Brand	JetMister JM35
Head Office	Quercus Court, Armstrong Way, BS37 5NG
Telephone	01454 513 000
Email	info@dustquip.co.uk
Website	www.dustquip.co.uk

CE & UKCA MARKING

All machines are identified with a Model & Serial ID plate which includes the CE & UKCA marking

	DUSTQUIP		
Manufactured By: Dustquip Ltd Armstrong Way, Yate Bristol, BS37 5NG	Mfg. Date:	<input type="text"/>	
	Serial No:	<input type="text"/>	
	Model:	<input type="text"/>	
	Power:	<input type="text"/>	
 Bristol UK +44 (0)1454 513 000	Weight:	<input type="text"/>	
SP001			

Some machines may have a UKCA label affixed to the machine adjacent to the Serial Number plate.

UKCA DECLARATION OF CONFORMITY



Dustquip Ltd Declaration of Conformity

In accordance with UK Government Guid-

1. **Product Model**

- A. Product: Mobile JetMister Trolley
- B. Model: JM35
- C. Serial: 1000-99999
- D. Specification: Trolley mounted or static diesel/electric powered high Pressure, high flow jet misting unit.

2. **Manufacturer**

- A. Name: Terracore Group Ltd
- B. Address: Quercus Court, Armstrong Way, Yate, BS37 5NG (UK)

3. This declaration is issued under the responsibility of the above mentioned manufacturer.

4. The object of the declaration described above is in conformity with the relevant UK Statutory Instruments and their amendments:

Supply of Machinery (Safety) Regulations 2008

Noise Emission in the Environment by Equipment for use Outdoors Regulations 2001

Electromagnetic Compatibility Regulations 2016

Radio Equipment Regulations 2017 (where remote control fitted)

The Restrictions of the Use of Certain Hazardous Substances in Electrical and Electronic Equipment Regulations 2012

5. **Additional information:**

The technical documentation for the machinery is available from:

- Name: Terracore Group Ltd
- Address: Quercus Court, Armstrong Way, Yate, BS37 5NG
- Signed for & behalf of: Dustquip
- Place of issue: Yate, United Kingdom
- Name: Neal Davies

- Position: Director

- Signature: Neal Davies *Neal Davies*

CE DECLARATION OF CONFORMITY



Terracore Group Ltd
EC Declaration of Conformity

In accordance with EU Government Guid-

1. Product Model

- A. Product: Mobile JetMister Trolley
- B. Model: JM35
- C. Serial: 1000-99999
- D. Specification: Trolley mounted or static diesel/electric powered high pressure, high flow jet misting unit.

2. Manufacturer

- A. Name: Terracore Group Ltd
- B. Address: Quercus Court, Armstrong Way, Yate, BS37 5NG (UK)

3. This declaration is issued under the responsibility of the above mentioned manufacturer.

4. The object of the declaration described above is in conformity with the relevant EU Statutory Instruments and their amendments:

Machinery Directive 2006/42/EC

Outdoor Noise Directive 2000/14/EC

Electromagnetic Compatibility - Directive 2014/30/EU

Radio equipment - Directive 2014/53/EU

Restriction of the Use of certain Hazardous Substances in Electrical and Electronic Equipment (RoHS) - Directive 2002/95/EC

5. Additional information:

The technical documentation for the machinery is available from:

- Name: Terracore Group Ltd
- Address: Quercus Court, Armstrong Way, Yate, BS37 5NG
- Signed for & behalf of: Dustquip
- Place of issue: Yate, United Kingdom
- Name: Neal Davies

- Position: Director

- Signature: Neal Davies *Neal Davies*

 **DUSTQUIP**



PARTS & SERVICE

WWW.DUSTQUIP.COM

SP044

Terracore Group Ltd T/A Dustquip

+44(0) 1454 513 000

Quercus Court
Armstrong Way
Yate
BS37 5NG

www.dustquip.co.uk
info@dustquip.co.uk