

OVELL®

Fluid Management Equipment Manufacturer





Ceramics



Chemicals



Dry Powder



Mining



Oilfield



Paint and Ink



Surface



Paper



Health



Semiconductor



Wastewater

The World's Leading Manufacturer of Fluid Management Equipment

The company focus on the research, development, production, and sales of high-performance pneumatic diaphragm pumps



OVELL PUMP - Overalllead, the world's leading manufacturer of fluid management equipment, was founded in the United States. In 2017, it authorized Chinese Overalllead factory production and has set up sales offices in the United States, Australia and New Zealand. The company focuses on the research, development, production, and sales of high-performance pneumatic diaphragm pumps, metering pumps, water quality monitoring instruments, and complete medicinal equipment. OVELL diaphragm pumps are designed for efficiency, durability, and versatility, making them ideal for industries such as Chemical Processing, Petrochem, Pharmaceuticals, Paint, Ink&Dyes, Mining, Civil Works, Wine&Beverage, Dairy, Pulp&Paper, Water Treatment and Food Production. With ISO9001, CE, FDA & ATEX certifications, providing reliable and high-performance diaphragm pump solutions to customers worldwide.



- ◆ Reliable pneumatic reciprocating system, stable operation, strong dirt resistance, no dead spots.



- ◆ Excellent ball valve assembly, no cutting fluid, maximum allowable 10mm solid particle pass through and have a longer life, a higher suction stroke and a longer lift.



- ◆ The advanced diaphragm is more flexible and more wear-resistant. Various diaphragm materials, can meet many needs from different industries.



- ◆ The maximum particle diameter of the pneumatic diaphragm flap valve pump is up to 50mm. The flap valve pump suction inlet is through the top manifold and outlet is via the bottom manifold. So that the fluid can be easily drained and discharged.



- ◆ The unique gas distribution system of the pneumatic powder pump makes it possible to transport bulk density at 50~850KG/m³ dry powder.

- ◆ Integrated diaphragm without outer piston, no risk of leakage. Longer service life and wear resistance, suitable for conveying various corrosive materials



Aluminum

Pump

Commonly Used Pump Types	A05APXXX	A10AAXXX	A15AAXXX	A20AAXXX	A30AAXXX
Size	1/2"	1"	1-1/2"	2"	3"
Max Working Pressure (Bar)	6.9	8.3	8.3	8.3	8.3
Max Dry Suction (m)	5	6.8	5.2	6.2	6.1
Max Flow Rate (L/Min)	62	172	380	680	902
Max Particle Diameter (mm)	2.5	3.2	6.5	6.5	10
Weight (kg)	4.5	8.2	23	30	52

	1/2"	1"	1-1/2"	2"	3"
L	225	241.5	385	498	597
B	160	210	310	330	420
H	305	351	500	651	792
C	51	34	39	48	60
D	229	287	431	565	678
E	157	124	261	330	387
F	120	120	160	220	240
G	10	10	10	17	17
I	1/4"-18NPT	1/4"-18NPT	3/8"-14NPT	3/8"-14NPT	3/8"-14NPT
K	1/2"-BSPT	1"-BSPT	1-1/2"-BSPT	2"-BSPT	3"-BSPT

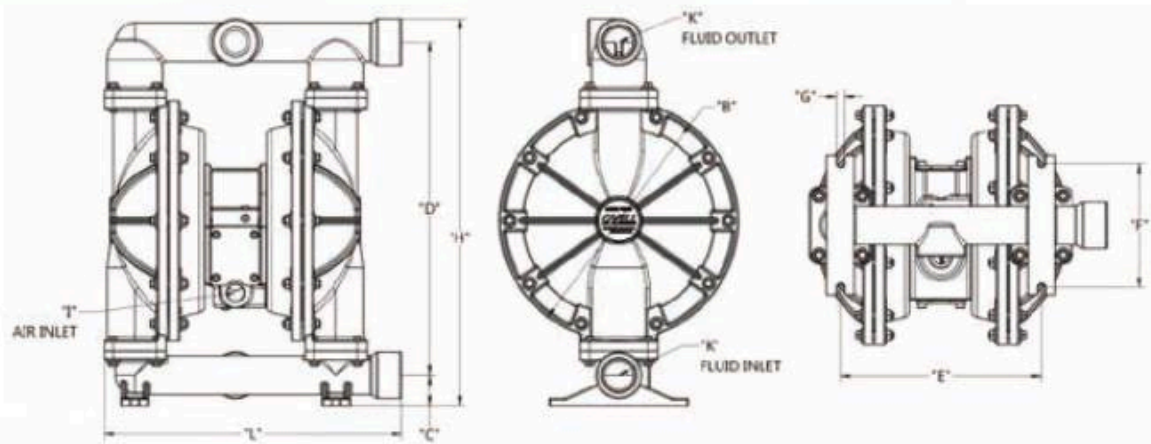

Stainless Steel & Cast Iron

Pump

	1/2"	1"	1-1/2"	2"	3"
L	230	224.1	341	445	527
B	160	210	310	330	420
H	294	346	500	651	792
C	51	34	39	48	60
D	229	291	431	565	678
E	157	124	261	330	387
F	120	120	160	220	240
G	10	10	10	17	17
I	1/4"-18NPT	1/4"-18NPT	3/8"-14NPT	3/8"-14NPT	1/2"-14NPT
K	1/2"BSPT	1"BSPT	1-1/2"BSPT	2"BSPT	3"BSPT

Commonly Used Pump Types	A05SPXXX	A10SAXXX	A15S(W)XXX	A20S(W)XXX	A30S(W)XXX
Size	1/2"	1"	1-1/2"	2"	3"
Max Working Pressure (Bar)	6.9	8.3	8.3	8.3	8.3
Max Dry Suction (m)	5	6.8	5.2	6.2	6.1
Max Flow Rate (L/Min)	62	172	380	680	902
Max Particle Diameter (mm)	2.5	3.2	6.5	6.5	10
Weight (kg)	8.5	14	40/37	63/60	110/102

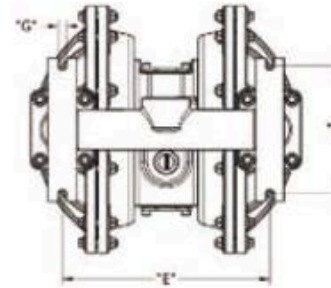
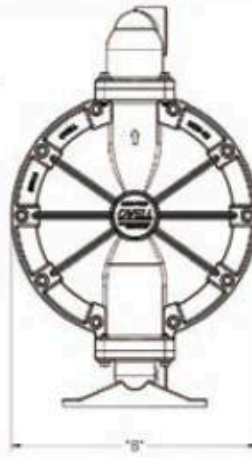
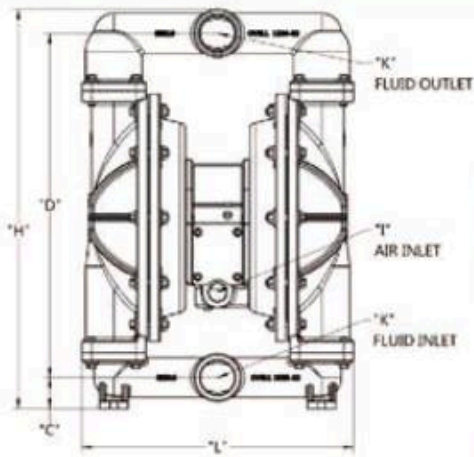

Wastewater



Freighter



Chemistry



Coating



Papermaking



Car

Food Grade

Pump

Commonly Used Pump Types	A05SPXXX-F	A10SAXXX-F	A15SAXXX-F	A20SAXXX-F	A30SAXXX-F
Size	1/2"	1"	1-1/2"	2"	3"
Max Working Pressure (Bar)	6.9	8.3	8.3	8.3	8.3
Max Dry Suction (m)	5	6.8	5.2	6.2	6.1
Max Flow Rate (L/Min)	62	172	380	680	902
Max Particle Diameter (mm)	2.5	3.2	6.5	6.5	10
Weight (kg)	8.5	14	40	63	110

	1/2"	1"	1-1/2"	2"	3"
L	230	241.5	341	445	527
B	160	210	310	330	420
H	294	346	500	651	792
C	51	34	39	48	60
D	229	291	431	565	678
E	157	124	261	330	387
F	120	120	160	220	240
G	10	10	10	17	17
I	1/4-18NPT	1/4-18NPT	1/4-14NPT	1/4-14NPT	1/4-14NPT
J	34	50.5	64	77.5	91
K	21.3	38(1-1/2")	51(2")	63.5(2-1/2")	76.1(3")

(ISO2852)

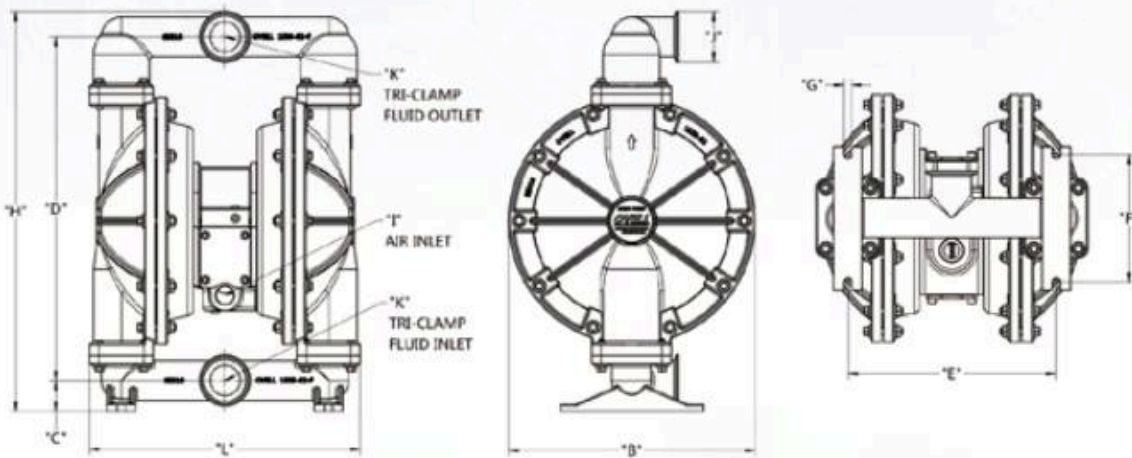

125 Ra electropolished Fluid contact areas are all FDA-compliant. ✦

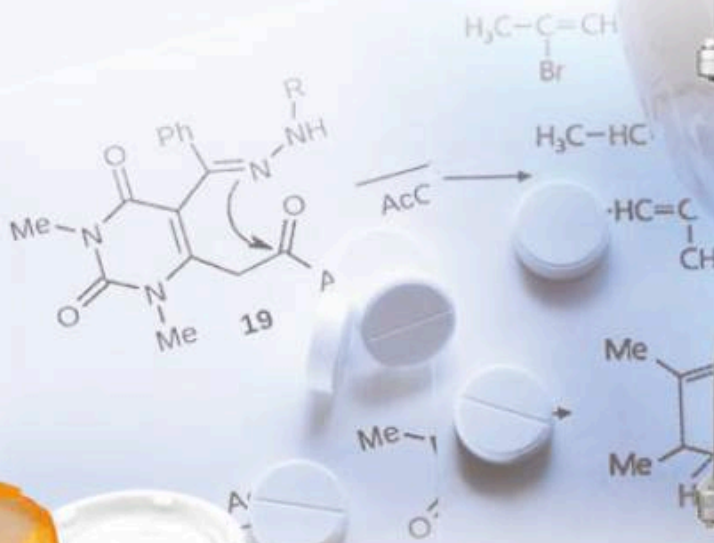

PP & PVDF

Pump

	1/4"	1/2"	1"	1-1/2"	2"	3"
L	145	234	349	455	455	661
B	114	160	205	330	330	420
H	163	308	432	738	745	1001
C	25	50	63	90	90	123
D	115	238	313	575	575	783
E	61	171	139	340	340	450
F	53	119	102	240	240	279
G	6	8	13	18	18	19
I	1/4-27NPT	1/4-18NPT	1/4-18NPT	1/2-14NPT	1/2-14NPT	3/4-14NPT
K	1/4"FNPT	1/2"BSPT	1"ANSI Flange	1-1/2"ANSI Flange	2"ANSI Flange	3"ANSI Flange

Commonly Used Pump Types	A02P(K)PXXX	A05P(K)PXXX	A10P(K)PXXX	A15P(K)PXXX	A20P(K)PXXX	A30P(K)AXXX
Size	1/4"	1/2"	1"	1-1/2"	2"	3"
Max Working Pressure (Bar)	6.9	6.9	8.3	8.3	8.3	8.3
Max Dry Suction (m)	3	4.1	4.3	5.1	5.4	4.8
Max Flow Rate (L/Min)	17	62	172	480	680	902
Max Particle Diameter(mm)	1	2.5	3.2	6.5	6.5	10
Weight (kg)	0.8/1.4	3.2/4.5	7.5/10	30/42	32/43	58/75

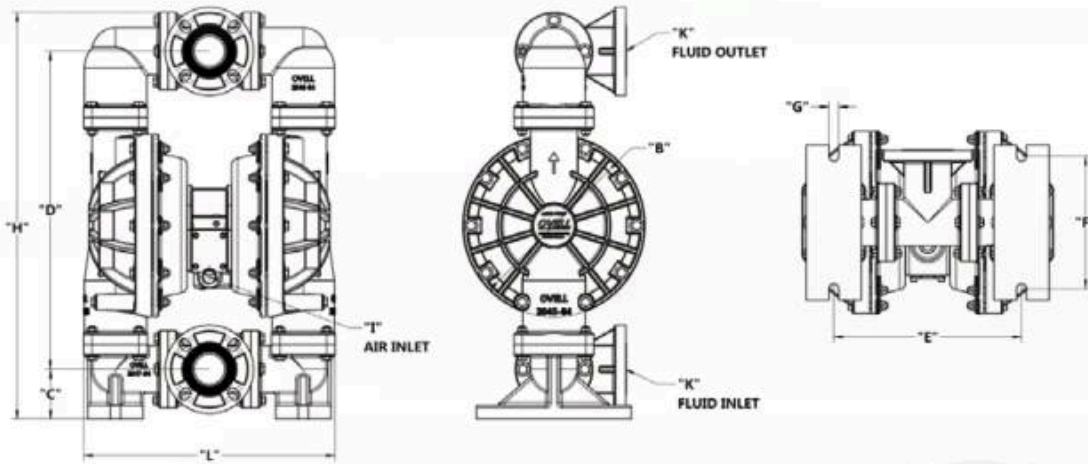

Wastewater



Ceramics



Chemistry



Coating



Pharmaceutical



Car

Pneumatic Flap Valve

Pump



Commonly Used Pump Type	FA15AAXXS	FA20AAXXS	FA30AAXXS
Size	1-1/2"	2"	3"
Max Working Pressure (Bar)	8.3	8.3	8.3
Max Dry Suction (m)	4.2	4.5	4.5
Max Flow Rate (L/Min)	380	680	902
Max Particle Diameter (mm)	25	38	50
Weight (kg)	30	40	60

	1-1/2"	2"	3"
A	519	546	696.5
B	310	330	420
C	233	262	314.6
D	197	222	262.6
E	136	160	210
F	96	110	150
G	10	12	12
H	569	608.5	776.5
I	3/4 NPT	3/4 NPT	3/4 NPT
J	1-1/2"BSPT	2"BSPT	3"BSPT
K	78	74.2	102.5
L	510	544	755.6

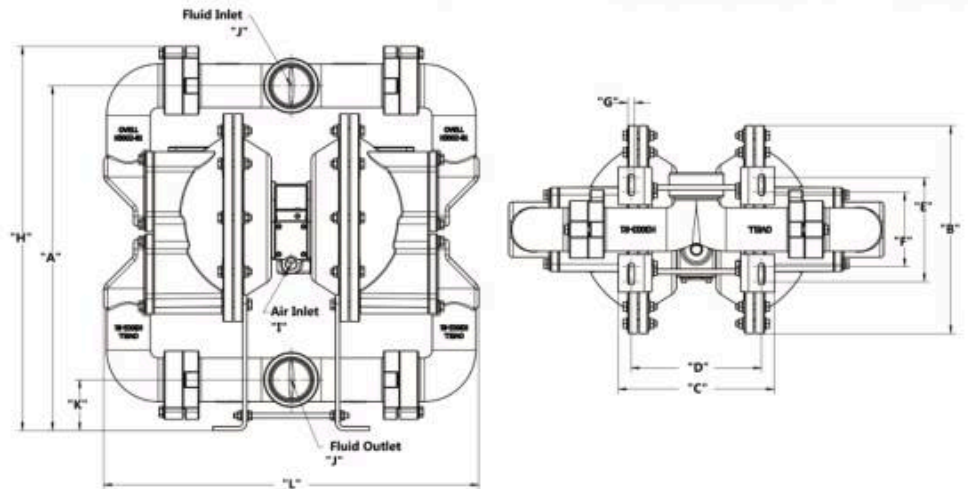

◆ With Inlet up and outlet down design, the fluid can be drained and exhausted.

Micro-agitated movement avoids heating the fluid, no sparks and no heat is generated. ◆

The shear force is small, and the complete and initial state of the fluid are restored. ◆

Simple installation, convenient and easy to use. ◆

◆ Good tightness, no leakage of materials throughout, avoiding contact between personnel and fluid.

◆ Theoretical maximum allowable particle diameter is up to 50mm.



◆ Economical and practical, the cost is only 1/10 of the traditional equipment, and the maintenance is simple.

Pneumatic Powder

Pump



Commonly Used Pump Type	PA20AAXXX	PA30AAXXX
Size	2"	3"
Max Working Pressure (Bar)	8.3	8.3
Max Dry Suction (m)	30	30
Max Flow Rate (L/Min)	2.5	4.5
Max Particle Diameter(mm)	6.5	10
Weight (kg)	30	52

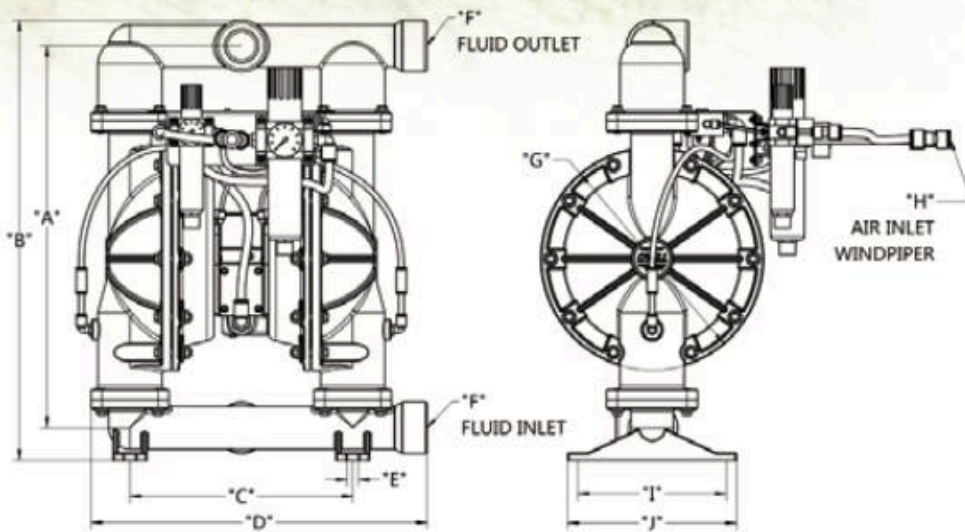

	2"	3"
A	651	792
B	565	678
C	330	387
D	498	597
E	17	17
F	2"BSP	3"BSP
G	330	420
H	Φ16	Φ16
I	220	240
J	250	280

Simple installation, easy to use, the product is convenient to move, ready to use anytime, no need to debug. ✦

✦ Good tightness, no leakage of materials throughout, avoiding contact between personnel and fluid.

Economical and practical, the cost is only 1/10 of the traditional equipment, and the maintenance is simple. ✦

✦ Micro-agitated movement avoids heating the fluid, no sparks and no heat is generated.



✦ Maximum conveying capacity 4.5T/h, maximum conveying height 30m.

✦ The shear force is small, and the complete and initial state of the fluid are restored.

Can transport bulk density 50~850kg/m³ powder. ✦

Pneumatic Booster

Pump

Commonly Used Pump Types	ZA15SAXXX	ZA20SAXXX	ZA30SAXXX
Size	1-1/2"	2"	3"
Max Working Pressure (Bar)	14	14	14
Max Dry Suction (m)	140	140	140
Max Flow Rate (L/Min)	380	680	902
Max Particle Diameter (mm)	6.5	6.5	10
Weight (kg)	60	80	120

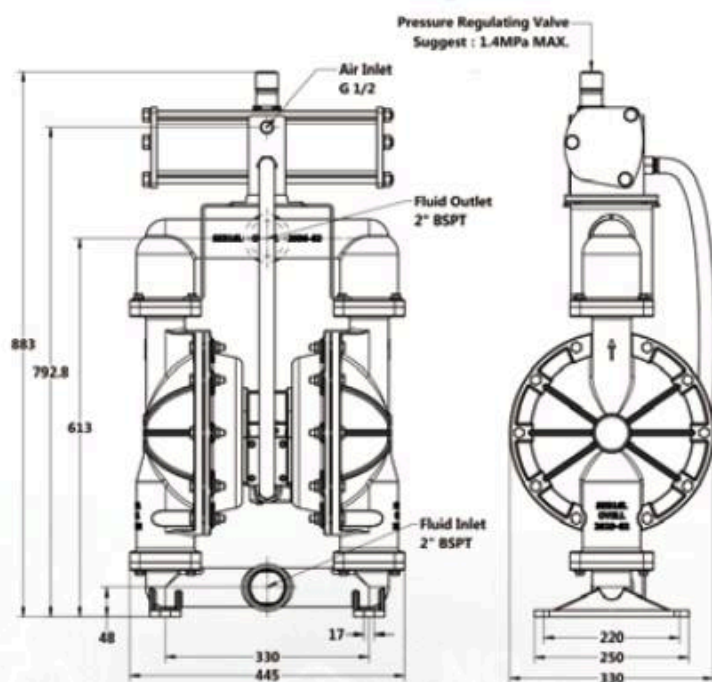

ZA20SAXXX 安装尺寸

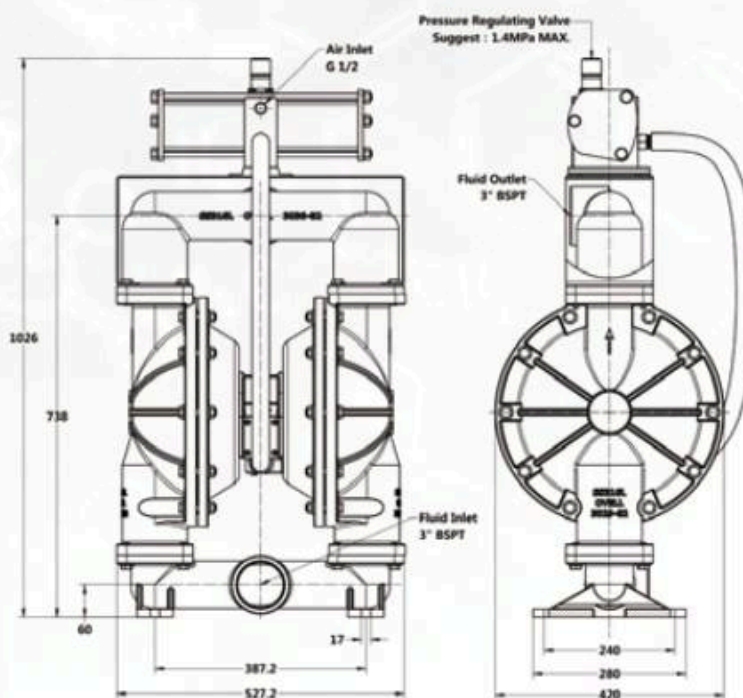

ZA30SAXXX 安装尺寸



Step-less adjustment of the boosting ratio(1-2 times),no need to deliberately control the air source pressure. ✦

✦ The pressure value dial display can monitor and stably output the pressure value in real time.

Suitable for conveying materials with higher viscosity. ✦

✦ The shear force is small,and the complete and initial state of the fluid are restored.

Micro-agitated movement avoids heating the fluid,no sparks and no heat is generated. ✦

✦ Optimized diaphragm and ball valve have reliable performance and longer life.

The flow rate can reach up to 902L/Min,and the lift can reach up to 140 meters. ✦

✦ Economical and practical,the cost is only 1/10 of the traditional equipment,and the maintenance is simple.



OVELL Diaphragm Pulse Dampener

Shell material: PP, PVDF, SUS304, SUS316L, etc.

Diaphragm material: PTFE, FPM, EPDM.

D		X		X		X		-X	
Series		Size (Volume/caliber)		Shell Material		Diaphragm Material		Special Request	
D	Pulsation damper	05	0.35/DN15	P	Polypropylene	T	PTFE	L	Ban Copper and Zinc
		06	0.6/DN20	K	PVDF	E	ERDM		
		10	1.5/DN25	S	SS316L	V	VITON		
		15	4.0/DN40	D	SS304				
		20	4.0/DN50						



◆ Reduce the peak value of flow rate fluctuations.



Reduce the harm of water hammer to the system. ◆

Protect pipelines, valves and joints from the impact of pressure fluctuations. ◆



◆ Create a good working environment for metering pumps and improve pump performance.

Allow the system to use a smaller pipe diameter and reduce costs. ◆



◆ Used in conjunction with a back pressure valve, etc., the pressure fluctuation of the pipeline can be close to zero.



Reduce the energy consumption of the system. ◆



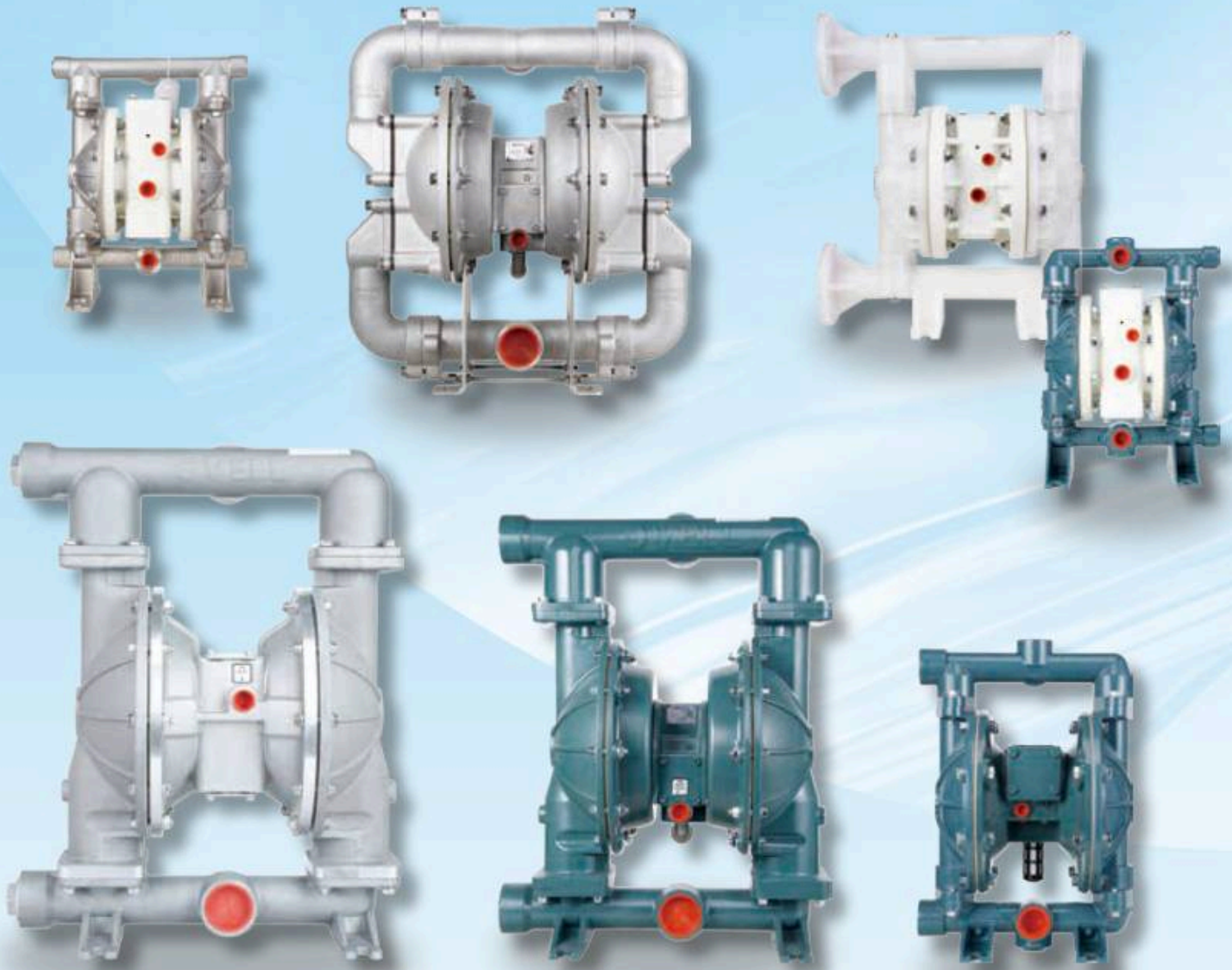

Pump Description System

X		X		X		X		X		X					
Series	Size	Material of Manifolds or Fluid Caps		Motor Body Material		Diaphragm Material		Valve Ball Material		Valve Seat Material		Special Request			
A	Air Operated Double Diaphragm Pump	02	1/4"	A	Aluminum	A	Aluminum	T	PTFE	T	PTFE	A	Aluminum	-	Side Port
E	Electric Diaphragm Pump	05	1/2"	S	Stainless Steel	P	Polypropylene	G	Santoprene	G	Santoprene	S	Stainless Steel	C	Central Port
FA	Flap Valve Diaphragm Pump	10	1"	W	Cast Iron			N	Neoprene	N	Neoprene	W	Cast Iron	SJ	Double Inlet / Outlet
ZA	Booster Diaphragm Pump	15	1-1/2"	p	Polypropylene			B	Nitrile	B	Nitrile	p	Polypropylene	F	Food Grade Port
PA	Powder Diaphragm Pump	20	2"	K	PVDF			V	Viton	V	Viton	K	PVDF	CF	Flange Port
		30	3"					E	EPDM	E	EPDM			L	Ban Copper and Zinc



Temperature Limits of Commonly Used Materials

Commonly Used Materials and Introduction	Max. Temperature Limit	Min.
Aluminum alloy: medium corrosion resistance and wear resistance, lightweight, economical, large industry coverage, and wide versatility.	302°F / 150°C	-40°F / -40°C
SS316 stainless steel: excellent corrosion resistance and wear resistance, widely used in food, medicine, electronics and other industries.	570°F / 300°C	-300°F / -200°C
Cast Iron: It has weak corrosion resistance, but excellent wear resistance, is relatively economical, and is widely used in environmental protection, ceramics and other industries.	570°F / 300°C	14°F / -10°C
Polypropylene: A thermoplastic polymer, moderate tensile and flex strength. Resists strong acids and alkali. Attacked by chlorine, fuming nitric acid and other strong oxidizing agents.	175°F / 79°C	32°F / 0°C
PVDF: (Polyvinylidene Fluoride) A durable fluoroplastic with excellent chemical resistance. Excellent for UV applications. High tensile strength and imp act resistance.	250°F / 121°C	0°F / -18°C
Neoprene: All purpose. resistance to vegetable oils. Generally not affected by moderate chemicals, fats, greases and many oils and solvents. Generally attacked by strong oxidizing acids, ketones, esters and nitro hydrocarbons and chlorinated aromatic hydrocarbons.	200°F / 93°C	-10°F / -23°C
Nitrile: General purpose, oil-resistant. Shows good solvent, oil, water and hydraulic fluid resistance. Should not be used with highly polar solvents like acetone and MEK, ozone, chlorinated hydrocarbons and nitro hydrocarbons.	190°F / 88°C	-10°F / -23°C
Santoprene®: Injection molded thermoplastic elastomer with no fabric layer. Long mechanical flex life. Excellent abrasion resistance.	275°F / 135°C	-40°F / -40°C
EPDM: Shows very good water and chemical resistance, Has poor resistance to oils and solvents, but is fair in ketones and alcohols.	280°F / 138°C	-40°F / -40°C
Viton FKM(fluorocarbon): Shows good resistance to a wide range of oils and solvents; especially all aliphatic and halogenated hydrocarbons, acids, animal and vegetable oils. Hot water or hot aqueous solutions (over 70°F) will attack KFM.	350°F / 177°C	-40°F / -40°C
Virgin PTFE: (PFA/TFE) Chemically inert, virtually impervious. Very few chemicals are known to chemically react with PTFE. molten alkali metals, turbulent liquid or gaseous fluorine and a few fluoro-chemicals such as chlorine trifluoride or oxygen difluoride which readily liberate free fluorine at elevated temperature.	220°F / 104°C	-35°F / -37°C



OVELL®

GLOBAL SERVICE

Office address · America · Australia

📍 America: 700 Nicholas BLVD STE 102D , ELK Grove village, IL, 60007
Australia: Level 4, 830 Whitehorse Road, Box Hill, VIC, 3128

✉ sales@ovellpump.com

🌐 www.ovellpump.com

Factory address · China

📍 Floor 8-9, Building 2, No. 3, Chanxing 1st Road, Xianchong Village, Chencun Town,
Shunde District, Foshan City, Guangdong Province, P.C 528313, China

✉ saleschina@ovellpump.com

🌐 www.ovellpump.com