

## BLS: SYSTEM FOR PROTECTIVE RELAY TEST (TEST BLOCK & TEST PLUG)

This datasheet applies to BLS Systems of categories B, D, F and K.  
The handling and use of these products must be carried out by personnel trained in Electrical Power System Protection.

### TERMINAL BLOCKS & TEST SWITCHES by Megger®

<b>GENERAL</b>	
<b>Product</b>	BLS: Test Block and Test Plug
<b>Description</b>	The BLS system consists of a Test Block and a Test Plug. The Block is composed of different quantities and functions of circuits according to their category. It has main circuits for the current, voltage, and trip functions and includes two auxiliary contacts for signaling.
<b>Test Block Configuration</b>	The CONFIGURATION is composed of: CATEGORY (B, D, F, K) + NUMBER OF CIRCUITS (Trips + Voltages + Current Groups) + Options.
<b>Test Block Options</b>	<p>1.- <b>CONFIGURATION Group:</b> GROUP <b>A</b> - Contains subgroups of <b>0</b> or <b>2</b> Current Circuits. GROUP <b>B</b> - Contains <b>a</b> subgroup of multiple Current Circuits. GROUP <b>C</b> - Contains multiple Current Circuits subgroups.</p> <p>2.- <b>CONFIGURATIONS Variant:</b> (Interchange of circuit position) Variant <b>9:</b> Factory-configured (standard). Variant <b>8:</b> Other customizations Variant <b>7:</b> Includes circuits for (+) and (-).</p> <p>3.- <b>Mounting:</b> (V = Vertical, H = Horizontal).</p>
<b>Test Plug Options</b>	There are two variants of the test connector: <b>Variant A</b> isolates all circuits of the test block. <b>Variant B</b> does not isolate the first or last contact of the test block, which is required for operation with variant 7 test blocks.
<b>Operation</b>	<p>The <b>Test Block</b> and <b>Test Plug</b> operate in an interlocked manner. When the <b>Test Plug</b> is inserted, it triggers the switching of the internal circuits of the <b>Test Block</b>, allowing the instrument to be isolated from the primary electrical equipment to which it is connected. When the <b>Test Plug</b> is fully inserted (100%) into the <b>Test Block</b>, analog signals can be injected into the instrument to verify its proper operation. Each <b>Test Plug</b> can only be inserted into a <b>Test Block</b> of the same category with the same number of poles.</p> <p><b>OPERATION SEQUENCE</b></p> <p><b>POSITION 0: IN SERVICE.</b> (PLUG outside BLOCK) When inserting the PLUG into the BLOCK, the first 2 events are carried out until reaching position 1 where the PLUG remains locked in.</p> <ul style="list-style-type: none"> <li>1<sup>st</sup> - Operation of auxiliary contacts.</li> <li>2<sup>nd</sup> - Interruption of the trip circuits.</li> </ul> <p><b>POSITION 1: TRIP BLOCKED.</b> (PLUG in intermediate position) To move the PLUG to position 2, it is necessary to press the release lever and insert the PLUG all the way to carry out the following events.</p> <ul style="list-style-type: none"> <li>3<sup>rd</sup> - Short-Circuiting the currents.</li> <li>4<sup>th</sup> - Interruption of current circuits.</li> <li>5<sup>th</sup> - Interruption of voltage circuits.</li> <li>6<sup>th</sup> - PLUG Connection - Instrument.</li> </ul> <p><b>POSITION 2: TOTAL BLOCK.</b> (PLUG is at the bottom of block) In this position the PLUG is locked again and access to the instrument terminals is available through the PLUG terminals for injection of analog signals for testing to the instrument. To move the PLUG from position 2 to position 1, it is necessary to press the release lever and release it before reaching position 1, and from position 1 to position 0, press the release lever again.</p>

### TERMINAL BLOCKS & TEST SWITCHES by Megger®

	<div style="text-align: center; background-color: #0070C0; color: white; padding: 5px; border-radius: 10px; font-weight: bold;">SEQUENCE OF OPERATION K, F, B and D</div> <p><b>CIRCUIT</b>      % PROGRESS OF THE PLUG INTO THE BLOCK / CONTACTS STATE</p> <table border="1" style="width: 100%; border-collapse: collapse;"> <tr> <td style="width: 10%;"></td> <td style="width: 10%;">0</td> <td style="width: 10%;">20</td> <td style="width: 10%;">40</td> <td style="width: 10%;">50</td> <td style="width: 10%;">60</td> <td style="width: 10%;">70</td> <td style="width: 10%;">80</td> <td style="width: 10%;">90</td> <td style="width: 10%;">99</td> </tr> <tr> <td><b>Trip</b></td> <td colspan="3">Closed</td> <td>Open</td> <td colspan="5">PLUG Connection - Instrument</td> </tr> <tr> <td><b>Voltage</b></td> <td colspan="4">Closed</td> <td>Open</td> <td colspan="4">Plug - Instrument</td> </tr> <tr> <td><b>Current</b></td> <td colspan="5">Closed</td> <td>Open</td> <td colspan="3">PLUG- Instrument.</td> </tr> <tr> <td><b>Short</b></td> <td colspan="3">Open</td> <td colspan="6">Closed (Continuity between entry and return)</td> </tr> <tr> <td rowspan="2"><b>Auxiliary</b></td> <td><b>NO</b></td> <td colspan="3">Open</td> <td colspan="5">Closed</td> </tr> <tr> <td><b>NC</b></td> <td colspan="3">Closed</td> <td colspan="5">Open</td> </tr> </table> <p style="text-align: center;"> <span style="margin-right: 150px;">Position 0. →</span> <span style="margin-right: 150px;">Position 1 →</span> <span>Position 2 →</span> </p>		0	20	40	50	60	70	80	90	99	<b>Trip</b>	Closed			Open	PLUG Connection - Instrument					<b>Voltage</b>	Closed				Open	Plug - Instrument				<b>Current</b>	Closed					Open	PLUG- Instrument.			<b>Short</b>	Open			Closed (Continuity between entry and return)						<b>Auxiliary</b>	<b>NO</b>	Open			Closed					<b>NC</b>	Closed			Open				
	0	20	40	50	60	70	80	90	99																																																													
<b>Trip</b>	Closed			Open	PLUG Connection - Instrument																																																																	
<b>Voltage</b>	Closed				Open	Plug - Instrument																																																																
<b>Current</b>	Closed					Open	PLUG- Instrument.																																																															
<b>Short</b>	Open			Closed (Continuity between entry and return)																																																																		
<b>Auxiliary</b>	<b>NO</b>	Open			Closed																																																																	
	<b>NC</b>	Closed			Open																																																																	
<b>Composition</b>	<p>Conductors made of tinned copper, encased in polycarbonate-based insulating plastic, and stainless-steel components.</p> <p>The point contacts in main circuits of the Test Block are made of pure silver.</p>																																																																					
<b>Mounting</b>	Mounting is available in horizontal or vertical orientation.																																																																					
<b>Presentation</b>	Plastic housing and stainless-steel accessories.																																																																					
<b>Additional Information</b>	<ul style="list-style-type: none"> <li>- Rear connection ring-type terminal for 10, 12, and 14 AWG gauge wires.</li> <li>- Designed for use with Instrument Transformers.</li> <li>- Indoor Use ONLY. To be mounted inside protection cabinets.</li> </ul>																																																																					

### TECHNICAL DATA

PARAMETERS	TEST BLOCK VALUES				TEST PLUG VALUES
	B	D	F	K	B, D, F, K
CATEGORIES	<b>10</b>	<b>14</b>	<b>18</b>	<b>24</b>	N/A
Main Circuits					N/A
Auxiliary Contacts	2				N/A
Short-time Withstand Current	400 A, 1 S				200 A, 1 S
Rated Nominal Current	20 A				12 A
Maximum Operating Voltage	600 V ca				600 V ca
Low Frequency Withstand Voltage	2,500 V, 60 Hz, 1 min				2,000 V
Main Contact Resistance (Average)	< 2.5 mΩ				< 20 mΩ
Main Contact Resistance (Maximum)	< 5.0 mΩ				< 40 mΩ
Temperature Range	-25° to +50° C				-25° to +50° C
Accepted Terminal Types	Ring or Blade Type				Insulated Banana Plug
Accepted Terminal Size	10, 12 o 14 AWG				4 mm
Auxiliary Contacts	3 A, 250 Vca				N/A
Connection Screw Tightening Torque	1.1 N-m (154 oz.in) +/- 0.1 N-m				N/A
Mounting Screw Tightening Torque	0.9 N-m (127 oz.in) +/- 0.1 N-m				N/A
Interlocking for Trip Blocking	YES				YES
Current Interruption-Free	YES				N/A
Limited 3 Year Manufacturer Warranty	YES				YES

Side View – BLS Test Block



Side View – BLS Test Plug

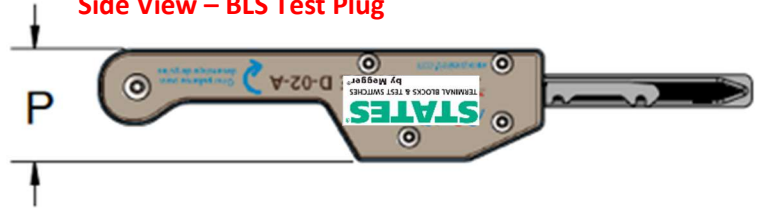

Top View – BLS Test Block

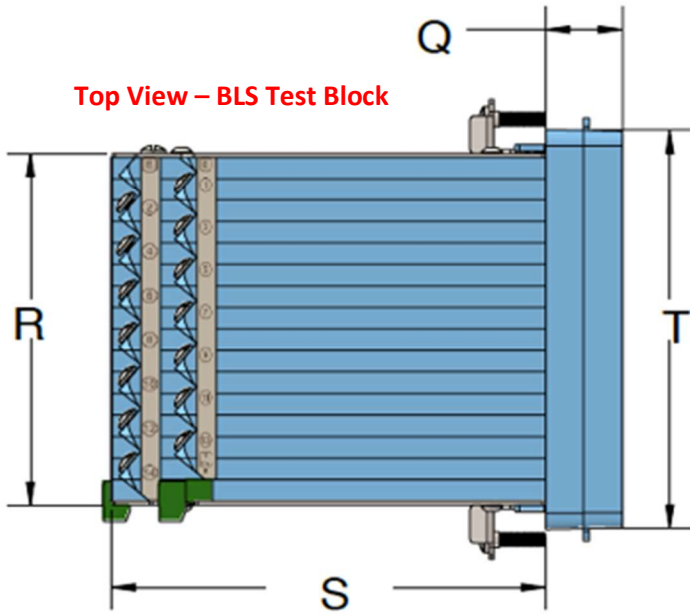

Top View – BLS Test Plug

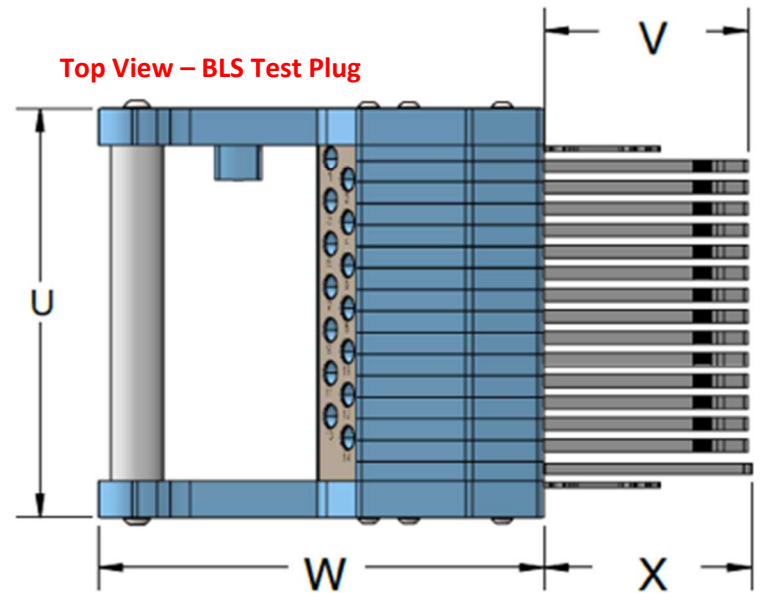

### DIMENSIONS

VARIABLE	CATEGORIES			
	B	D	F	K
M	50.0	50.0	50.0	50.0
N	61.5	61.5	62.0	60.6
Q	27.9	27.9	27.9	27.9
R	99.0	131.0	163.0	211.0
S	132.5	132.5	132.5	132.5
T	117.0	150.0	183.0	230.0
P	41.5	41.5	41.5	41.5
U	120.0	152.0	184.0	232.0
V	73.3	73.3	73.3	73.3
W	160.0	160.0	160.0	160.0
X	74.7	74.7	74.7	74.7
Tolerances	+/- 0.5	+/- 0.5	+/- 1.0	+/- 1.0
Dimensions in mm				

TERMINAL BLOCKS & TEST SWITCHES  
by Megger®

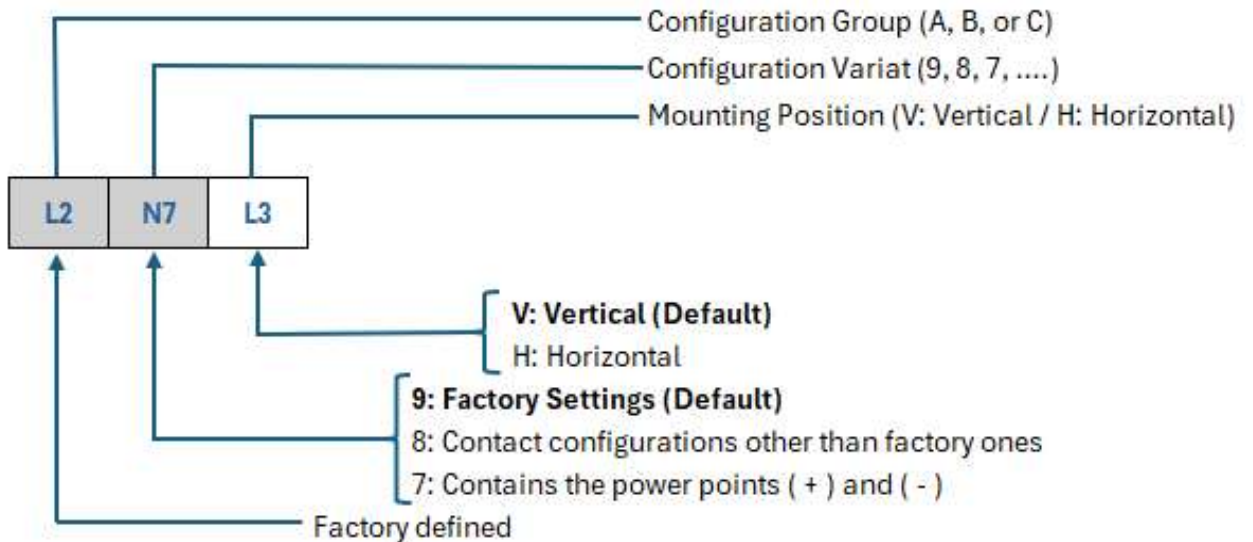
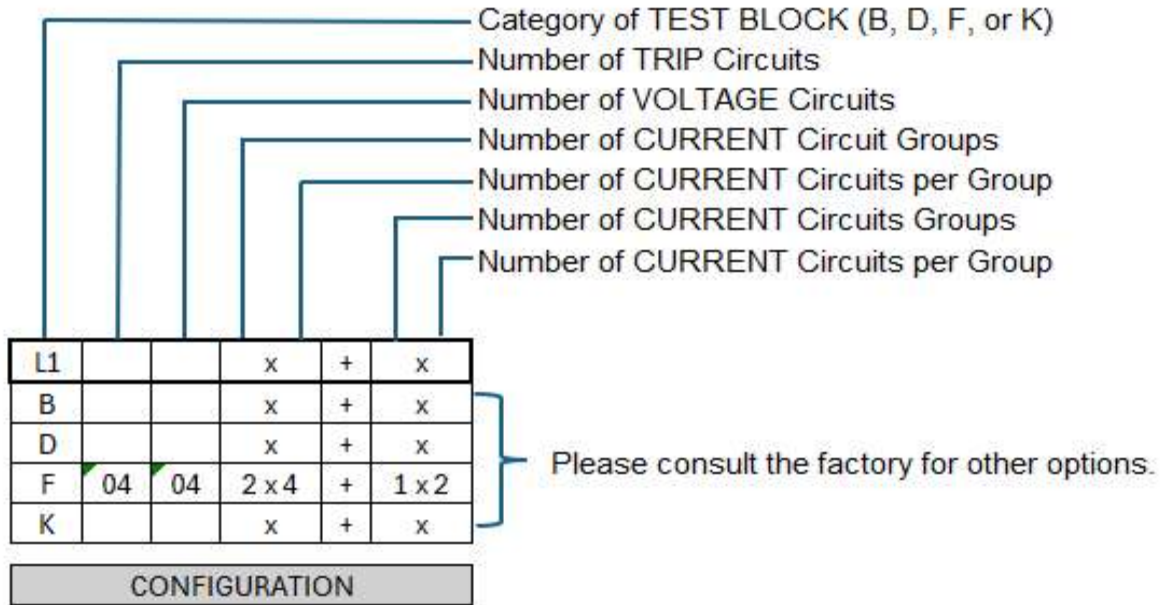

## BLS TEST BLOCK MOUNTING

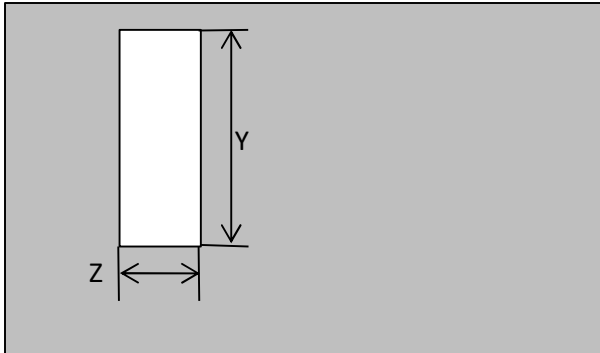

### CUT-OUT DIMENSIONS FOR TEST BLOCK

CATEGORY	B	D	F	K
Y	106.0	138.0	170.0	218.0
Z	51.5	51.5	51.5	51.5
Dimensions in mm Tolerances +/- 0.5				

### WEIGHT (Kg)

CATEGORY	B	D	F	K
TEST BLOCK	1.0	1.3	1.6	2.0
TEST PLUG	0.7	1.0	1.2	1.5

## BLS TEST PLUG



## TEST PLUG SPECIFICATION

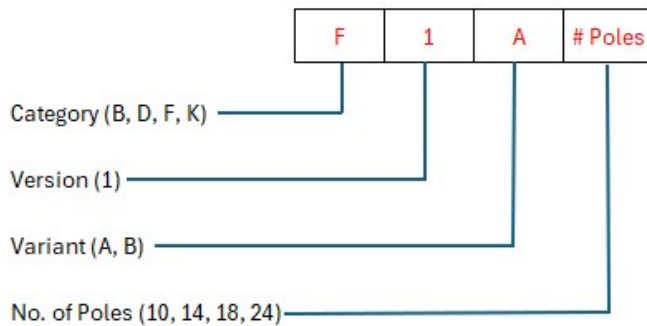

Part Number Example: **F1A14**

TEST BLOCK			TEST PLUG	
CATEGORY	CIRCUITS	OPTIONS	VARIANT	POLES
K	24	V/H	1A / 1B	24
F	18	V/H	1A / 1B	18
D	14	V/H	1A	14
B	10	V/H	1A	10