

March 2026

Contact information

Settlement & Clearing Services
Department
Mizuho Bank, Ltd.

Market Profile

Japan

Table of Contents

I. Types of Securities	5
A. Stocks	5
1. Listed stocks	5
2. Developments related to listed stocks	5
3. Unlisted stocks	7
B. Listed funds	8
1. Exchange-traded Funds (ETFs)	8
2. Real Estate Investment Trusts (J-REITs)	8
C. Bonds	9
1. Japanese Government Bonds (coupon-bearing JGB/CPI-linked JGB/TB)	9
2. Municipal bonds	9
3. Corporate bonds	10
4. Convertible bonds	10
5. Warrant bonds	10
6. Samurai bonds	10
II. Securities Markets and Indices	11
A. Securities markets overview	11
B. List of Exchanges	13
1. Tokyo Stock Exchange (TSE)	13
2. Osaka Exchange (OSE, former Osaka Securities Exchange)	17
3. Nagoya Stock Exchange (NSE)	17
4. Fukuoka Stock Exchange (FSE)	18
5. Sapporo Securities Exchange (SSE)	18
6. Proprietary Trading System (PTS)	18
C. Indices	19
III. Settlement and Clearing Institutions	20
A. Central securities depositories	20
1. Japan Securities Depository Center (JASDEC)	20
2. Bank of Japan (BOJ)	20
B. Clearing houses	20
1. Japan Securities Clearing Corporation (JSCC)	21
2. JASDEC DVP Clearing Corporation (JDCC)	21
IV. Securities and Cash Settlement	23
A. Securities settlement system	23
1. JGBs at BOJ	23
2. Other securities at JASDEC	23
B. Cash settlement system	24
1. BOJ-Net Funds Transfer System	24
2. Foreign Exchange Yen Clearing System (FXYCS)	24
3. Discussions on the use of CLS in FX transactions	25
C. Securities settlement process	26
1. Settlement flow for securities traded by non-residents in the Japanese market	26
2. Settlement cycle for stocks, corporate bonds, municipal bonds, and JGBs	27
3. Settlement workflow between sub-custodian and clients	30
4. Trading and settlement of various securities	31
5. Market deadlines	32
D. Buy-ins	33

1. Rare in the Japanese market	33
2. Rules governing buy-ins	33
E. Market practice for failed JGB trades	35
F. Other points of consideration	35
V. Settlement Finality and Registration	36
A. Equities held at JASDEC	36
B. JGBs in Book-Entry form	36
C. Bonds held at JASDEC	36
D. Physical security certificates (unlisted shares, old long-term bonds only)	36
VI. Regulations	38
A. Foreign investment regulations	38
B. Large shareholdings reporting requirement	40
1. Requirements	40
2. Penalties	40
C. Restrictions on direct inward investment stipulated by the Foreign Exchange & Foreign Trade Act	41
VII. Taxation	48
A. General taxation treatment of non-residents	48
1. Applicable tax rates	48
2. Capital gains tax	48
B. Securing tax relief for non-residents on DTTs	48
1. Function of DTTs	48
2. Eligible entities	48
3. Article of limitation on benefits	48
C. Tax exemption for bonds held by non-residents	49
1. Structure of tax exemption	50
2. Eligible entities	50
3. Application procedures	50
4. How tax status of bonds affects trading	51
D. Tax reclaim	53
1. Overview	53
2. Steps to be taken	53
3. Standard timeframe	54
4. Statute of Limitation	54
VIII. Regulatory Authorities	55
A. Overview	55
1. Financial Services Agency (FSA)	55
2. Securities and Exchange Surveillance Commission (SESC)	55
3. Bank of Japan (BOJ)	55
4. Self-regulatory organizations (SROs)	55
B. Regulatory structure	56
IX. Corporate Actions	57
A. Types of Corporate Actions in Japan	57
1. Mandatory events	57
2. Voluntary events	58
3. Corporate actions affecting bonds	58
B. Tender offer regulations	59
1. Definition of tender offer	59
2. Tender offer rules	60

3. Issues for non-residents	60
C. Calculation of FOL entitlements	61
1. Entitlement	61
2. Fractional shares	63
D. Details of proxy voting	63
1. Overview	63
2. Online Shareholder Meeting	63
3. Determining entitlement	63
4. General operational flow for proxy voting	64
E. General flow of shareholder proposal on AGM agenda.....	66
1. Overview	66
2. Statutory requirements for AGM agenda proposal.....	67
3. Proving the fulfilment of statutory requirements.....	67
4. Required account structure	67
F. General flow of calling a Shareholders' Meeting	67
1. Overview	67
2. Statutory requirements for calling a shareholders' meeting.....	68
3. Proving the fulfilment of statutory requirements.....	68
4. Required account structure	68
G. Attendance of non-resident investors to AGM.....	69
1. Overview	69
2. Four potential ways to attend an AGM	69
X. Cycle for entitlements: Comparison with other markets	70
A. Important dates for entitlements	70
1. Record date	70
2. Ex-date	70
3. Pay date	70
4. Announcement date	70
B. Comparison of dividend payment timeframes.....	71
1. Standard timeframe for dividend payment in Japan	71
2. Standard timeframe for dividend payment in US	71
3. Comparison	71
4. Reasons for the difference	72
A. Custody accounts.....	73
1. Main Account.....	73
2. Sub-account	73
3. "My Number" reporting requirement.....	73
B. Yen correspondent accounts.....	74
C. Application of OECD CRS framework	74
XII. Websites of relevant entities	76
XIII. Timetable of recent/expected market developments.....	79
Appendix: Standard Documents for Foreign Investors Opening Accounts and Applying for Tax Breaks in Japan.....	80

I. Types of Securities

Japan's cash securities market, consisting primarily of stocks and bonds, is nearly completely "dematerialized." Therefore, issuers do not ordinarily print securities certificates and ownership is tracked by account management institutions (AMIs) digitally. Dematerialization is the rule for listed stocks, exchange-traded notes (ETNs), exchange-traded funds (ETFs), real estate investment trusts (J-REITs), listed preferred equity investments, bonds with equity warrants, commercial paper, municipal bonds, and corporate bonds. Ownership of these securities is recorded in electronic form at the Japan Securities Depository Center, Inc. (JASDEC), which is one of Japan's two CSDs. Japanese Government Bonds (JGBs) are also dematerialized, and are held at Japan's other CSD, the Bank of Japan (BOJ). Consequently, physical certificates for any security are extremely rare in the Japanese market. Stocks of some unlisted companies and old bonds issued prior to dematerialization are such examples. Each security is assigned an ISO 6166 compliant 12-digit ISIN code starting with "JP" followed by a 6-digit issuer code, 3-digit security type code, and 1 check digit.

Principal types of stocks and bonds are described below.

A. Stocks

1. Listed stocks

Non-residents generally prefer to invest in listed rather than unlisted stocks. A listed company (Joujyou Gaisha) should not be confused with a public company (Kokai Gaisha). In Japan, whether the issued stocks can be sold/transferred without the issuing company's permission is defined in the company's articles of incorporation. A public company is a company that permits its stocks to be sold/transferred. Meanwhile, a listed company is a public company whose stocks are traded on the stock exchange. Listed company stocks are always safe-kept and settled at the CSD. The following types of stocks are listed on the major securities exchanges.

Common stock

This is the most ordinary form of stock. It confers no special privileges or limits to rights.

Preferred stock

Preferred stock takes priority over common stock in terms of dividend payments and claims on residual assets and earnings in the case of bankruptcy, but it usually does not confer voting rights. The opposite is deferred stock, which is subordinated to common stock in claims on residual assets in the case of bankruptcy.

Other stock classifications

Less common types of stock include the following:

- (1) Shares with transfer restrictions
- (2) Shares with redemption rights
- (3) Shares that do not confer voting rights
- (4) Shares with restricted voting rights
- (5) Shares with rights to require the issuing company to issue new shares
- (6) Shares with veto rights over company's important resolution matters (golden shares)

2. Developments related to listed stocks

Trading unit system of stocks

A trading unit is the minimum number of stocks for trading set for each issue. The number of stocks recognized as one trading unit is defined in a company's articles of incorporation*. One trading unit entitles shareholders to one voting right, and shareholdings amounting to less than one trading unit do not entitle voting rights. Japan's stock exchanges only permit trades in trading units, but trades of less than one unit can be conducted off-market and settled at JASDEC. Shareholders who hold a specific number of trading units as defined by the Company's Act are entitled to make proposals at annual general meetings (AGMs), such as to demand dismissal of directors, and to amend the articles of incorporation.

*Since 1 October 2018, the trading unit used by all the Japanese listed companies has been unified to 100 shares, to make trading more efficient and eliminate order errors. Accordingly, the cost of a single trading lot of any given stock on the exchange should be calculated by timing the price indicated by 100.

Tick size

The price increment at which an order to buy or sell is placed is called the tick size. Tick sizes are shown in Chart I-A below, depending on the issue to be traded and the price level of the issue.

*The TOPIX 100 includes Japan's largest listed companies, consisting by the "TOPIX Core30" and "TOPIX Large70". A full list of the constituents can be found at the following link:

<https://www.jpx.co.jp/english/markets/indices/topix/index.html>

Chart I-A: Tick Size

Price tick (Units: JPY)			
	TOPIX500* Constituents (TOPIX100 and TOPIX Mid 400) Also applied to ETFs, ETNs, and leveraged products with a trading unit of 10 or above	ETFs, etc. With trading unit of one unit (ETFs, ETNs, and leveraged products)	Other Shares
up to 1,000	0.1	1	1
up to 3,000	0.5	1	1
up to 5,000	1	1	5
up to 10,000	1	1	10
up to 30,000	5	5	10
up to 50,000	10	10	50
up to 100,000	10	10	100
up to 300,000	100	100	100
up to 500,000	50	50	500
up to 1,000,000	100	100	1,000
up to 3,000,000	500	500	1,000
up to 5,000,000	1,000	1,000	5,000
up to 10,000,000	1,000	1,000	10,000
up to 30,000,000	5,000	5,000	10,000
up to 50,000,000	10,000	10,000	50,000
over 50,000,000	10,000	10,000	100,000

Source: TSE; compiled by Mizuho.

*TOPIX500 is a combination of TOPIX100 and TOPIX Mid 400. TOPIX 100 includes Japan's largest listed companies, consisting by the "TOPIX Core30" and "TOPIX Large70". TOPIX Mid 400 includes issues that has large market capital and liquidity next to TOPIX 100 constituents.

A full list of the constituents can be found at the following link:

<https://www.jpx.co.jp/english/markets/indices/topix/index.html>

3. Unlisted stocks

As in other markets, stocks that do not meet the criteria of the securities exchanges are unlisted and traded directly between trading participants or over the counter (OTC). In general, non-residents tend to focus on issues that are listed on the securities exchanges and seldom invest in unlisted stocks. Unlisted stocks are not fully dematerialized, so the form of the stock certificates (dematerialized / physical etc.), is defined in each individual company's articles of incorporation. If a company does issue physical stocks, foreign investors must hold the stocks either with a custodian or the issuer; they themselves may not receive or hold the physical certificates. In any event, safekeeping and settlement is in principle never conducted at the central securities depository and instead is usually conducted by a trust bank on behalf of the issuer, although in rare cases issuers may conduct settlement themselves. The one exception is the so-called "phoenix shares," the stocks of delisted companies that maintain disclosure standards and announce indicative stock prices. The stocks of these companies are permitted to be held at the CSD even though they are not listed on an exchange. (As of March 2026, there are no phoenix shares in the market since June 2016.) The unlisted stock in Japan consists of the following categories:

OTC securities

This is the general term for unlisted or unregistered issues.

OTC-handled securities

This refers to OTC securities issued by companies that regularly disclose corporate information in compliance with continuous disclosure rules or in the form of a "Corporate Information Memorandum." They are regarded as carrying less risk than other unlisted securities.

Note: How JASDEC is involved in supporting unlisted companies

In order to facilitate settlements and asset services of unlisted shares, JASDEC publicized "The outline of handling of unlisted shares, etc. on book-entry transfer system of shares" in April 2023. In March 2024, JASDEC announced to change the guidelines to handle unlisted shares under the book-entry transfer system and became effective from April 2024. (As of February 2026, there are no JASDEC eligible unlisted shares using this scheme) JASDEC describes, shares issued by the following issuers are going to be eligible for JASDEC.

< Type of unlisted shares to be JASDEC eligible >

- Shares issued under the Shareholders Community framework instituted by Japan Securities Dealers Association (JSDA)
- Shares issued under the JSDA Shares and Investment Trusts for Professionals (J-Ships) framework
- Shares issued by issuers that file an Annual Securities Report under the Financial Instruments and Exchange Act
- Shares issued by listed companies (e.g., classified shares, etc.)
- Shares listed at the Proprietary Trading System (PTS)

JASDEC requires "No restriction of transfer" placed on the above-mentioned issues to grant the eligibility.

B. Listed funds

The following funds are listed on the TSE.

1. Exchange-traded Funds (ETFs)

Exchange-traded Funds (ETFs) are unincorporated funds sponsored by an asset/fund management company and listed on stock exchanges. They have ISIN numbers, their prices are updated real time during trading hours like other listed stocks, and every aspect of trading and settlement is identical to stocks. However, they do not represent ownership of a single company but rather hold interest in diverse financial instruments. Japanese ETFs used to only track specific domestic and overseas stock indices, but now there are various types, such as commodity ETFs, bond ETFs and REIT ETFs.

Previously there were requirements for ETFs regarding minimum numbers of investment units, unit holders, and trading volume to maintain listings; however, TSE abolished them in 2007. As of February 2026, there are 384 ETFs listed. All ETFs are listed on the TSE, except for one being listed on Nagoya Stock Exchange (NSE) and another listed on multiple stock exchanges, TSE, NSE, Fukuoka Stock Exchange (FSE), and Sapporo Securities Exchange (SSE).

TSE started taking applications for initial listing of actively managed ETFs from 30 June 2023. As of February 2026, 30 actively managed ETFs are listed.

Exchange-traded notes (ETNs) are akin to ETFs. These are listed debt instruments issued by a financial institution that track the value of a stock index or the value of a commodity but that are not backed by any assets and are redeemable on demand. While they incur increased credit risk due to the sponsor not owning the underlying assets, this very feature allows them to eliminate the risk that their performance will diverge from that of the underlying asset. Interestingly, although ETFs are regulated by the self-regulating organization Investment Trusts Association, Japan (JITA), ETNs are not investment trusts, and no self-regulating organization oversees them. The TSE has 21 ETNs listed in February 2026.

TSE took over spot trading of the Osaka Exchange (formerly known as the Osaka Securities Exchange)'s ETFs and ETNs since 16 July 2013.

2. Real Estate Investment Trusts (J-REITs)

REITs are pools of capital invested into real estate, with rent and proceeds from sales of properties returned to investors as dividends. REITs were first developed in Japan following an amendment to the Investment Trust Act in November 2000. Referred to as J-REITs, these instruments can be structured either as a special-purpose corporation (SPC) or as a trust, although the former is much more common and more attractive to investors due to the application of corporate governance regulations—including annual general meetings. Under TSE listing criteria, over 70% of the investment assets must be real estate. Listed J-REITs must have at least 4,000 units outstanding, and the total net asset should be JPY 1 billion or more. Japan's J-REITs merely hold assets and have no operations or employees whatsoever. Asset management, building maintenance, and all other operations are outsourced to external companies.

The TSE and FSE have J-REIT markets. However, J-REITs are listed on the TSE only, with the exception of one being dually listed on both the TSE and FSE. The TSE has 58 J-REITs listed as of February 2026.

C. Bonds

1. Japanese Government Bonds (coupon-bearing JGB/CPI-linked JGB/TB)

Japanese government bonds (JGBs) are issued by the central government for financing purposes.

Chart I-C-1: Types of JGBs

	Description	Type	Minimum face value
Short term	6-month T-bill	Discount bond	JPY50,000-
	1-year T-bill	Discount bond	
Medium term	2-year JGB	Coupon bearing	JPY50,000-
	5-year JGB	Coupon bearing	
Long term	10-year JGB	Coupon bearing	JPY 50,000-
	10-year JGB	CPI-linked	JPY 100,000-
Super long term	20-year JGB	Coupon bearing	JPY 50,000-
	30-year JGB	Coupon bearing	JPY 50,000-
	40-year JGB	Coupon bearing	JPY 50,000-

Previously, taxable entities were not permitted to buy CPI-linked JGBs or Treasury Discount Bills (T-bills) and only designated financial institutions and non-taxable entities could purchase them.

In January 2015, the Minister of Finance of Japan (MOF) further eased the regulation to allow individual retail investors to hold CPI-linked JGBs. This transfer restriction was eased further in January 2016 to allow all types of investors to hold CPI-linked JGBs regardless of its maturity.

The MOF also lifted the transfer restriction on STRIPS (principal-only book-entry transfer JGBs and coupon-only book-entry transfer JGBs), and T-Bills altogether, on or after 1 January 2016. Consequently, now, all types of investors, including retail individual investors and taxable institutional investors, are allowed to hold STRIPS and T-Bills.

The BOJ has made necessary adjustments on the BOJ-Net system, and the relevant rules of the BOJ have also been amended to accommodate this deregulation by the MOF.

In February 2024, MOF issued the first “Japan Climate Transition Bond” to finance GX (Green Transformation), which aims to transform fossil fuel-centric industry to become greener. The Japanese government decided to issue JPY 20 trillion of GX Economy Transition Bonds over the next 10 years.

In December 2024, MOF announced the basic product features for the new Floating-rate JGBs. The former Floating-rate JGBs were suspended after their last issuance in May 2008, and they were fully redeemed by May 2023. At the basic design stage, the tenors for the new Floating-rate JGBs are to be 2 years and 5 years, and the coupon rates will reference the 6-month T-Bill issue yield. MOF is currently undertaking steps toward the issuance.

2. Municipal bonds

Municipal government bonds are issued by prefectures and municipalities for financing purposes based on the Local Autonomy Law. Municipal bonds have maturities of over a year and are usually 5-year or 10-year fixed-income debt. However, some issues carry longer maturities of 20 or 30 years. They can be issued via public or private placement and may be underwritten by either the public or private sector. Also, joint local government bonds can be issued jointly by two or more local governments.

3. Corporate bonds

Corporate bonds are classified into three categories: general corporate bonds, electric company bonds (ten listed power companies in Japan), and other (NTT, NHK, JR railway companies). They can be either publicly or privately issued (in this case, the distinction between public and private issuance refers to whether the bonds are issued to a large number of undesignated investors, and regardless of its listing on a securities exchange). Only companies whose stocks are listed may list their bonds on an exchange.

4. Convertible bonds

A convertible bond is a hybrid security. It is a type of bond that can be converted into equities at a date fixed by the issuing company under certain conditions.

5. Warrant bonds

Warrant bonds are issued and sold along with a warrant which entitles its holders to buy new stocks at a predetermined price. They are similar to convertible bonds. The principal difference between the two is that when they are exercised, convertible bonds cease to exist, whereas warrant bonds continue to exist. Both convertible bonds and warrant bonds result in the creation of new shares when exercised.

6. Samurai bonds

Like “Yankee bonds” in the US and “bulldog bonds” in the UK, samurai bonds are yen-denominated bonds issued by non-Japanese companies in the Japanese market. As they are issued in Japan, the bonds are subject to Japanese regulations.

II. Securities Markets and Indices

A. Securities markets overview

The merger of the TSE and the OSE

Although there are currently four securities exchanges in Japan*, the domestic securities exchange market is dominated by the Japan Exchange Group, Inc. (JPX), which was created in January 2013 from the merger of the Tokyo Stock Exchange Group, Inc. (TSE) and the Osaka Securities Exchange Co., Ltd. (OSE, currently known as Osaka Exchange). The merged company includes the principal exchanges of the two exchange operators, as well as their ancillary markets (see below). JPX is listed on the TSE market.

On 16 July 2013, roughly 700 companies listed on the First and Second Sections of the OSE were integrated into the two sections of the TSE. OSE-listed companies were bound to adopt the rules, regulations, and trading systems of the TSE. Since delisting standards were more stringent for TSE in terms of market capitalization, number of shareholders, and the number of floating shares, the TSE delisting standards were imposed on former-OSE companies after a three-year grace period. The two sections that comprise the OSE's main markets have thus ceased to exist.

*Japan has three other securities exchange operators in Nagoya, Fukuoka, and Sapporo that together account for roughly 0.1% of stock exchange trading volume.

Integration of TOCOM

At the end of July 2019, JPX announced to commence the tender offer for shares of Tokyo Commodity Exchange (TOCOM), in order to make TOCOM a subsidiary of JPX in October 2019. The basic agreement between JPX and TOCOM was to formulate a "comprehensive exchange" that offers one-stop trading for wide range of products from financial instruments to commodity derivatives. JPX acquired 97.5% of total voting rights in TOCOM by the tender offer for TOCOM which ended on 25 September 2019, and TOCOM became a consolidated subsidiary of JPX on 1 October 2019. On 1 November 2019, JPX acquired the remaining shares through squeeze-out, making TOCOM a wholly owned subsidiary of JPX.

On 27 July 2020, futures & options on precious metals, rubber and agricultural products traded over TOCOM were transferred to OSE to start the "comprehensive exchange" plan. It allowed trade financial and commodity derivatives at a single exchange. The driving force was the widening gap between the domestic commodity derivatives market and the overseas markets. The global commodity derivatives market has grown constantly, and the market size became more than eight times as large in the recent 15 years, while in Japan, the commodity derivatives market has significantly shrunk to one-seventh of market size compared to the size 15 years ago.

Following the transfer of futures & options on precious metals, rubber and agricultural products to OSE, TOCOM remained to be the commodity exchange to trade energy related products such as crude oil and electricity.

The startup markets

The securities market for startups, JASDAQ was previously part of OSE but became one of TSE's two startup markets (the other one was called "Mothers"). JASDAQ stock exchange was Japan's largest market for startups, with 694 companies listed and a daily average trading volume of 70.6 million stocks in December 2021. Despite the merger of TSE with OSE, JASDAQ retained its own listing and delisting standards.

Market Reorganization at TSE

TSE commenced reviewing the structure and the listing criteria of its 5 securities markets; TSE (1st and 2nd Section), JASDAQ (Standard and Growth Section), and Mothers. As for the first step, TSE solicited comments on its consultation paper to spot issues of the present market structure. Various comments were raised, such as the ambiguity in the concept of each market, especially among the 2nd Section of TSE, Mothers, and JASDAQ; the market structure lacking the mechanism to motivate listed companies toward sustainable growth of corporate value; the market index TOPIX, given the fact that the constituents are simply all the issues listed on the TSE 1st Section, was not satisfying as a benchmark nor a fair representation of the market.

Later in 2019, "Market Structure Expert Group" (Market Group) was formed under the Financial System Council to

explore the ideal stock market structure. JPX, the Ministry of Economy, Trade and Industry (METI), the Bank of Japan (BOJ), and the Japan Securities Dealers Association (JSDA) joined the meetings of the Market Group as observers. In December 2019, the Market Group released a paper on market restructuring and proposed to reshuffle the existing 5 markets to be reorganized into three: “Prime,” “Standard,” and “Growth.”

On 21 February 2020, TSE released “Overview of Market Structure Review and Outline of the New Market Segments” setting forth the outline and key milestones of the restructuring, targeting the completion of the market reorganization to be around 1 April 2022.

In April 2021, TSE announced the listing rules of the new market segments, procedures for listed companies for the transition and a “transitional measure” which would be applied to listed companies that do not meet the listing criteria for the new market segments.

On 9 July 2021, TSE notified the listed companies of the results of whether they met the criteria for the new market category based on their current statistics. Starting from September 2021, companies applied for the new markets they would like to move in. Companies could move to the new market even if they did not meet the criteria, but such companies were required to submit a plan for how it would meet the criteria in near future. (“transitional measure”)

The outline of the continued listing criteria of the three markets was as follows.

	Prime market	Standard market	Growth market
No. of shareholders	At least 800	At least 400	At least 150
No. of tradable share	At least 20,000 units	At least 2,000 units	At least 1,000 units
Tradable shares market cap	At least JPY 10bn	At least JPY 1bn	At least JPY 0.5bn
Minimum Market cap	-	-	JPY 4bn after 10 yrs from IPO
Minimum Trading value	Daily average JPY 20mn	Monthly avg trading vol 10 units	Monthly avg trading vol 10 units
Tradable shares ratio	At least 35%	At least 25%	At least 25%
Financial status	Net assets positive	Net assets positive	Net assets positive

On 11 January 2022, TSE announced the results of the selection of the market segments made by the listed companies. 1,841 companies chose to be listed on the Prime, the market for companies leading the global economy, which account for 84% of the companies listed on the TSE 1st Section. 1,477 companies chose to be listed on the Standard, the market for companies playing a central role in the Japanese economy, and 459 companies chose to be listed on the Growth, the market for companies taking on new challenges. The market restructuring became effective on 4 April 2022.

Special exception period (Apr. – Sep. 2023)

On 1 April 2023, TSE announced that they would start applying the regular continued listing criteria to the companies using the transitional measure from record date of each company on or after March 2025. Companies that chose to be kept listed on the Prime market were allowed an opportunity to move and were listed on the Standard market without any examination. Such companies were to submit their application by 29 September 2023, and ultimately, 177 companies listed on the Prime market chose to move. Those companies’ stocks started their listing on the Standard market from 20 October 2023.

Reviewing TOPIX index

Another proposal by the Market Group was the use of “free-float market cap” to eventually review TOPIX while emphasizing the importance of discreet transition with sufficient time frame to avoid causing excessive impact to the market. Since the original TOPIX constituents 100% overlapped with companies listed on the old TSE 1st Section, the constituents are mainly from the Prime market. However, the Market Group proposed this situation should be corrected, since the purpose of setting up multiple markets (Prime, Standard and Growth) is a different matter from selecting constituents that represent the market as a whole. The market index is working as the subject matter of investment as well as the market benchmark.

In December 2020, TSE announced its new calculation method that would be applied to TOPIX. The plan was to continue using the constituents as of 1 April 2022 (the old TSE 1st section companies), regardless of the new market segment which started from 4 April 2022, and eventually “weigh down” the constituents which do not satisfy the new criteria.

The review was conducted in the following manner. < **Phase 1** >

(a) The review began from October 2022 by setting a criteria JPY 10 billion in “tradable shares market capitalization” for each constituent. Companies that met these criteria as of July 2021 were automatically recognized as TOPIX constituent regardless of which market they were listed under the new market segment.

(b) Companies that failed to meet these criteria as of July 2021 were examined again based on the results of their latest fiscal year end (e.g. March end 2022) by October 2022. Companies that met the criteria were then recognized as TOPIX constituents.

(c) Companies that failed to meet the criteria in above (b) was categorized as “phased weighting reduction constituents”. Those constituents have been weighed down in 10 phases on the last business day of every quarter starting from 31 October 2022 and eventually removed from TOPIX on the last business day of January 2025. This approach was aimed at maintaining TOPIX’s continuity as an index and to minimize the impact to the market with consideration to liquidity.

(d) To reflect the improvement during the transition period, TSE also established a re-evaluation system. Companies categorized as “phased weighting reduction constituents” was re-examined on the results based on their latest fiscal year end (e.g. March end 2023) in October 2023, whether their tradable shares market capitalization is at or more than JPY 10 billion. Companies that failed to meet this level were eliminated from TOPIX on the last business day of January 2025, when their phased weighting reduction ratio reaches “nil”. For companies that met the standard of “JPY10billion in tradable share market capitalization”, were assessed by other criteria of “annual trading value turnover ratio (ATVTR)”. For those whose ATVTR is on or above 0.2, are recognized as regular TOPIX constituents via the gradual adjustment period of ATVTR. For those whose ATVTR was less than 0.2, are also recognized as TOPIX constituents, however, their phased reduction level is fixed at 0.6 and will not go up.

Further, stocks that are delisted, designated as “Securities to be Delisted” or designated as “Securities on Alert” will be excluded from the calculation of TOPIX.

On June 19, 2024, JPX announced a new reform proposal for TOPIX. < **Phase 2** >

JPX will further slim down the TOPIX constituents to the issuers that account for 96% of the TSE's market capitalization, based on free-float stocks basis that exclude cross-held shares. As a result, the remaining 4% of the issuers will be pushed out with the exclusion of companies with low market capitalization.

At present, TOPIX primarily encompasses companies in the Prime market at TSE. The new TOPIX will broaden the scope of eligibility to all 3 markets at TSE, with the view of adding companies with growth potential to the index. The additional change of components will be implemented gradually from October 2026.

B. List of Exchanges

1. Tokyo Stock Exchange (TSE)

System enhancement and high-speed trading (HST)

The TSE operates the Prime, Standard and Growth markets and also operates the systems for ETFs, J-REITs, bonds, derivatives, and other instruments which are not classified in the above three markets or any other designated markets.

TSE completed upgrading its low-latency trading system “arrowhead” on 11 November 2019 to further enhance response and to secure appropriate capacity. The TSE also offers co-location services and separate proximity services at the TSE primary site. In Japan, after the release of arrowhead in 2010, and the first upgrade in 2015,

high-speed trading (HST) has been common practice, and this new system shortened the response time drastically to a millisecond level.

With this enhanced trading system, coupled with the introduction of narrower tick sizes, the ratio of HST among the orders and confirmed trades on TSE has increased. In December 2018, about half of the orders on TSE were placed from the servers set up in the co-location service area offered by TSE utilizing algorithmic order placement tools.

Financial Services Agency of Japan (JFSA) has presented their idea to regulate investors that deploy HST strategy in late 2016. The gist of their plan was to have a trader registration framework in place to supervise high speed traders, which enabled JFSA to collect information about their trading activities. JFSA submitted a bill to amend the Financial Instruments and Exchange Act (FIEA) to regulate so-called HST traders and their activities, and FIEA was amended in May 2017. Under the amended FIEA, from 1 April 2018, those engaging in HST were required to register with JFSA. 10 HST service providers were initially registered under the framework, and the number of registered providers increased to 53 as of December 2024. The application forms for HST registration are available on the website of JFSA at the following URL.

<https://www.fsa.go.jp/en/regulated/hst/index.html>

In accordance, Japan Exchange Group (JPX) also monitors the traders that utilize HST by collecting order information based on the user ID of each participant that connects to their system. In this way, JPX will be able to see the overall ordering tactics of each JPX user.

This order information collection measure will allow JPX to directly and quickly confirm who placed an order, even when a trader is placing orders through a number of different brokers, at an extremely high speed, from servers set up in JPX's co-location service area, and, if JPX sees any necessity, will allow them to clarify details, thus improving the transparency of the market activities. TSE implemented a market rule from 4 January 2021 to prohibit so-called direct market access to improve the reliability and safety of the market to cope with the increasing number of high-speed and/or automated trading orders.

On November 2024, TSE launched its upgraded "arrowhead 4.0". The renewal includes an introduction of the closing auction session and a bulk order cancellation function for institutional investors. Additionally, to maximize trading opportunities and trading hours have been extended.

Trading hours: 9:00am to 11:30am, 12:30pm to 3:30pm. In connection with the launch of TSE's upgrade of "arrowhead 4.0", trading hours was extended to 3:30pm from 3:00pm from 5 November 2024.

Traded securities: Domestic and foreign stocks, ETFs, ETNs, JGBs, corporate bonds, foreign bonds, rights issues, J-REITs, convertible bonds, and derivatives. On 11 October 2023, TSE opened the Carbon Credit Market to trade carbon credits in Japan and announced the price of carbon credits.

Systems:

- arrowhead: domestic and foreign stocks, ETFs, REITs, CBs, and other spot market instruments
- Tokyo Stock Exchange Trading Network (ToSTNeT): single stock, basket, closing price, and off-auction repurchase of own shares

(For further details, please see <https://www.jpx.co.jp/english/equities/trading/tostnet/index.html>)

- For futures and options, TSE Tdex+ was switched over to the OSE J-Gate upon the consolidation of the TSE's derivatives market into the OSE's derivatives market on 24 March 2014.

On February 2021, TSE launched a platform named CONNEQTOR to provide RFQ (request for quote) function for ETFs. This was made to improve the liquidity of ETFs in the market by having a platform to facilitate transactions in large-scale which were difficult to execute in auction sessions.

Note: Single local time zone, JST, is set in Japan at GMT+9 hours, with no daylight-saving time. Not all bank holidays are fixed dates, and the date of some bank holidays changes every year.

TOKYO PRO Market

The TSE launched the new market for professional investors in June 2009 together with the London Stock Exchange

plc (LSE), modelled after the LSE's Alternative Investment Market (AIM). The TOKYO PRO Market's less rigorous listing and financial reporting standards make it better suited for professional investors rather than for individuals. It took two years for the TOKYO PRO Market to get its first listing in July 2011. In March 2012, TSE bought out the LSE's interest in the company and merged it into the parent company. As of February 2026, it has 168 companies listed.

Chart II-B-1: TOKYO PRO Market Overview

Disclosure	Reporting allowed in either Japanese or English
Accounting standards	IFRS, US GAAP, Japanese GAAP, and other approved standards
Regulation	Principles-based regulation that does not demand compliance with J-SOX or the filing of quarterly accounts
J-Advisor system (modeled on AIM's Nomad [nominated adviser] system)	J-Advisors are entities tasked with assessing firms' market suitability and ensure their ongoing compliance with regulations. Companies must retain a J-Advisors that is approved and monitored by the exchange to remain listed on the TOKYO PRO Market.
Target firms	Growth companies in Japan and Asia
Target investors	Institutional investors and investment funds who can cope with the low level of transparency

Trading hours: 9:00am to 11:30am; 12:30pm to 3:30pm.

Traded securities: Domestic and foreign stocks.

System: arrowhead.

TOKYO PRO-BOND Market

The TOKYO PRO Market launched the TOKYO PRO-BOND Market in March 2012, and it is now part of the Tokyo Stock Exchange. Like the TOKYO PRO Market, the TOKYO PRO-BOND Market is intended to provide a variety of issuers, including non-Japanese, with a new avenue to issue debt, while at the same time providing professional investors with a place to acquire them. On 30 March 2012, the TOKYO PRO-BOND Market announced ING Bank N.V. as its first listing, and as of February 2026, 11 companies are listing their debt programs.

TOKYO PRO-BOND Market has been attracting increasingly diversified issues. In 2013, the Asia Development Bank had its bond program approved as the first supranational organization, and in 2014, Bank of America Corporation also obtained approval as the first U.S. company to have its debt program there. In 2015, the Tokyo Metropolitan Government became the first Japanese municipality to list bonds there, and Japan Finance Organization for Municipalities has debuted with U.S. Dollar denominated bonds in February 2016. It is also the only market in Japan ready to list J-sukuk (yen-denominated Islamic bonds).

In January 2018, Green & Social bond platform was launched, where issuers listed on TOKYO PRO-BOND market are allowed to post information pertaining to Green and Social bonds. TSE does not certify any bond as a Green or Social bond and instead have the issuer to post an "external review" by a third party. On 29 June 2018, Japan International Cooperation Agency posted the first bond to this platform along with the external review posted by the Japan Research Institute.

The structure of TOKYO PRO-BOND market is intended to greatly simplify disclosure documents and procedures to allow issuing companies to issue bonds quickly and flexibly. The market also permits documentation to be made in English, allowing non-Japanese issuers to issue bonds at a lower cost.

Trading hours: 12:30pm to 3:30pm.

Traded securities: Domestic and foreign bonds.

System: Trades other than via the trading system. (The TSE has positioned the TOKYO PRO-BOND Market as a primary market with more relaxed; hence cheaper, issuing procedures. It is not designed to serve as a secondary

market.)

Infrastructure Fund Market

The Infrastructure Fund Market of TSE was launched at the end of April 2015, aiming to give opportunities to investors to diversify their portfolio into the infrastructure development and management sector. However, no funds were listed soon after the launch of the market due to the uncertainty in the available tax-exempt framework. When the Market was launched, infrastructure investment corporations were required to lower the ratio of infrastructure assets over total assets to 50% or less within 10 years in order to enjoy tax exemption as a conduit under the Act on Special Measures Concerning Taxation that sets forth various tax exemptions. However, the listing rule set by TSE as to the Infrastructure Funds Market requires the funds to hold at least 70% of infrastructure assets over the total assets.

Therefore, infrastructure funds that even though satisfied with the listing rule of TSE were exposed to the risk of being non-conduit, taxable entities on the Infrastructure Fund Market after 10 years of grace period. To counter this issue, and make the infrastructure investment market more active, JFSA submitted a request to amend the tax regulation to extend the 10-year grace period to 20 years. The request was approved in the tax policy for the fiscal year 2016 that commenced in April 2016. As the extension of tax relief period became likely, the first applicant submitted an application to TSE in December 2015, and TSE approved the first listing to its Infrastructure Fund Market on 4 April 2016. There are 6 funds listed as of March 2026. The overview of the Infrastructure Market of TSE is available at the following URL:

<https://www.jpx.co.jp/english/equities/products/infrastructure/outline/index.html>

2. Osaka Exchange (OSE, former Osaka Securities Exchange)

The OSE is also a subsidiary of the Japan Exchange Group. Until 15 July 2013, the OSE had operated cash equities markets, including JASDAQ. There have been certain changes made to the OSE and now it only maintains commodities and derivatives markets. On 16 July 2013, all OSE derivatives markets gained access to the TSE's co-location service in tandem with the OSE's adoption of TSE's arrowhead trading system. On the other hand, the derivatives market of the TSE was consolidated into the derivative market of the OSE on 24 March 2014. The trade name of the OSE was also changed to Osaka Exchange, Inc. on this day. OSE-FX, the market for foreign exchange margin trading under OSE, has been suspended since 23 October 2014. On 25 November 2014, OSE integrated its clearing system integration with that of Japan Securities Clearing Corporation (JSCC). On 22 August 2018, the U.S. Commodity Futures and Trading Commission (CFTC) granted an approval to OSE to be registered as a Foreign Board of Trade (FBOT) under the U.S. Commodity Exchange Act, allowing OSE to provide trading parties in the U.S. with direct access to OSE's trading system. On 27 July 2020, futures & options on precious metals, rubber and agricultural products traded at Tokyo Commodity Exchange (TOCOM) was transferred to OSE, and Japan Commodity Clearing House (JCCH), clearing house of commodity derivatives, was integrated to JSCC, to start a comprehensive exchange.

On 19 July 2016, OSE launched Next Generation Derivatives Trading System (J-GATE) as previously scheduled. According to its release made in June 2015, OSE introduced new products and trading rule revision at the launch of J-GATE. Major trading rule changes include (1) shifting the closing time of Night Session from 3am to 5:30am; (2) shifting the opening of Day Session from 9am to 8:45am; and (3) adding "Non-Cancel Period" limiting amendments/cancellations for some Index futures. The 15-minute extension in the morning was primarily made to cover the timing of important economic and financial indicators, such as GDP and the quarterly economic survey run by the Bank of Japan (so-called, Tankan), generally published at 8:50am JST. OSE started offering wider trading hour overlaps between the New York and Tokyo Market (5:30am in Tokyo is 4pm in New York Daylight Saving time), because the percentage points of night session trades against the total trades increased to 35% at its peak in 2015. Further, OSE commenced the trading of Nikkei 225 VI Futures in the night session to encourage use of the volatility index and attract new participants.

In May 2020, OSE announced the revision of trading rule for derivatives at the launch of Next Generation Derivatives Trading System (J-GATE 3.0). J-GATE 3.0 was launched on 21 September 2021, and revision of trading rule was made including (1) shifting the closing time of the Night Session from 5:30am to 6am Tokyo time, (2) shifting the opening of the Day Session for index options from 9am to 8:45am Tokyo time, and (3) introducing Nikkei 225 Total Return Index Futures (only Flexible Futures Trading) and CME Group Petroleum Index Futures..

Systems: The OSE uses J-GATE for derivatives and OSE-FX for foreign exchange margin trading.

In January 2020, OSE established a "Working Group on Derivative Holiday Trading" to discuss the implementation of derivative holiday trading, and the result of the discussions have been compiled and published in June 2020. The plan is for all current non-business days (excluding Saturdays, Sundays, and January 1st) to be applicable for holiday trading, with some exceptions for large scale system replacement and/or from the viewpoint of risk management, and participation in holiday trading to be optional (not mandatory). OSE and TOCOM announced the amendment to business regulations and related rules to be made to start derivatives holiday trading which was enforced on 21 September 2022.

3. Nagoya Stock Exchange (NSE)

The NSE has a first and second section. It also has the Centrex market for startups.

Trading hours: 9:00am to 11:30am; 12:30pm to 3:30pm; trading hours for JGBs, straight bonds, and foreign bonds are truncated and are each different.

Traded securities: Domestic stocks, ETFs, and domestic and foreign bonds

Systems: arrowhead; N-NET for off-auction trading.

4. Fukuoka Stock Exchange (FSE)

The FSE has one market section for stocks and another for bonds. For startups, it has the Q-Board.

Trading hours: 9:00am to 11:30am; 12:30pm to 3:30pm. Bonds are traded from 10:30am-11:00am only.

System: arrowhead

5. Sapporo Securities Exchange (SSE)

The SSE has one market section. For startups, it has Ambitious.

Trading hours: 9:00am to 11:30am; 12:30pm to 3:30pm. Bonds are traded from 10:30am-11:00am only.

System: arrowhead

6. Proprietary Trading System (PTS)

Proprietary Trading System (PTS) refers to an electronic trading platform that allows the buying and selling of securities without going through an exchange, primarily focusing on night-time trading when traditional exchanges are closed.

Japan once had a regulation requiring all stock trading to be centralized at exchanges, such as TSE. However, in 1998, this regulation was abolished to foster competition and improve market convenience. Subsequently, major broker-dealers started operating their own proprietary trading systems (PTS), but due to low trading volumes at the time, they eventually withdrew. As of March 2026, there are 3 operators in Japan (Japannext, Osaka Digital Exchange, and Japan Alternative Market.)

More than 80% of the total trading volume of the listed stocks is conducted through major exchanges like the TSE. PTS only accounts for roughly 10%. Although it is increasing, trading volume at PTS still remains relatively low compared to the United States where off-exchange trading covers about 40% of the total trading volume.

At one time, there were about 8 PTS (Proprietary Trading System) operators, including major broker-dealers. However, trading volume stagnated, partly because margin trading was not allowed, causing many operators to eventually exit the market. Since PTS operators are broker-dealers, there is a conflict of interest arising from PTSs themselves lending funds and securities for customers' margin trades. After regulatory easing allowed margin trading in daytime (nighttime is still prohibited) in 2019, PTS trading volume saw an increase.

In 2020, TSE experienced a system failure and had to halt the trading for an entire day. Since more than 80% of the stock transaction is done at TSE, this event served as a catalyst to reassess the necessity of PTS, highlighting the need for greater market resilience. Although PTS are currently regulated to keep trading volumes below a certain threshold, discussions are underway to ease these restrictions.

PTS operates much longer hours compared to TSE throughout the day as its daytime session is from 8:20am to 4pm and night session is from 4:30pm to 11:59pm Tokyo time.

C. Indices

Nikkei Inc., publisher of Japan's leading financial daily Nikkei Shimbun, calculates a number of indices using the Dow Jones method.

The Nikkei Stock Average

The Nikkei Stock Average ("Nikkei 225") is the most widely quoted index of Japanese equities. The Nikkei 225 tracks the 225 most actively traded issues on the TSE using the ex-rights adjusted average stock price of each component company. It is calculated by multiplying the stock price of each component stock by a "stock price conversion coefficient," which is an adjustment factor used to account for events such as stock splits and capital changes. By adjusting this coefficient, the impact of factors other than market fluctuations can be eliminated, thereby maintaining the continuity of the index. The constituent stocks are reviewed twice a year.

TOPIX

The second most closely watched stock index in Japan is TOPIX (Tokyo Stock Price Index), which is calculated and quoted by the TSE. This market capitalization-weighted index used to include all Japanese firms on the former TSE First Section. TOPIX is a true index that was set on 4 January 1968 with a base value of 100, and as such is not denominated in yen as is the Nikkei 225. The TSE also compiles many other indices, including those for individual industries and REITs. Please see the following link for a full description:

<https://www.jpx.co.jp/english/markets/indices/topix/index.html>

JPX-Nikkei Index 400

JPX-Nikkei Index 400 is an index jointly developed by Japan Exchange Group (JPX), the TSE and Nikkei Inc., which has been traded since January 2014. This index has a unique criterion in selecting its underlying components such as the return on equity to corporate governance framework and aims to offer a new investment option for investors. 400 constituents are chosen out from the TSE-listed companies. They are subject to annual reselection in August every year, based on the last business day in June. As a result of the annual review in 2025, the component issues include 390 from the Prime market and 10 from the Standard market, effective from 29 August 2025.

JPX-Nikkei Mid and Small Cap Index

In March 2017, TSE and Nikkei jointly launched another stock index, JPX-Nikkei Mid and Small Cap Index that tracks mid and small cap issues listed over Prime, Standard and Growth market of the TSE. The index is designed under the same concept as JPX-Nikkei Index 400 to encourage corporate management to pay greater attention to the elements focused by this index and enabling investors to diversify their portfolio into selected mid and small cap companies. 200 issues (179 from TSE first Section, 3 from TSE second Section, 3 from Mothers, and 15 from JASDAQ) were initially selected. The issues are subject to an annual review in August based on the last business day in June. As a result of the annual review in 2025, the component issues include 170 from the Prime market, 22 from the Standard market, and 8 from the Growth market, effective from 29 August 2025.

JPX Prime 150

In July 2023, TSE launched an index, JPX Prime 150 composed by stocks selected to represent "Japanese companies that are estimated to create value" from among the top-ranked stocks listed on the TSE Prime Market by market capitalization based on two measures of value creation: 1) "return on capital" which is based on financial results, and 2) "market valuation" which is based on future information and non-financial information. The components will be reviewed annually every August.

The full line up of the indices are available from the below JPX website:

<https://www.jpx.co.jp/english/markets/indices/line-up/index.html>

III. Settlement and Clearing Institutions

A. Central securities depositories

1. Japan Securities Depository Center (JASDEC)

As one of Japan's two central securities depositories, the Japan Securities Depository Center, Inc. (JASDEC) settles all trades and safekeeps all listed stocks and non-central government bonds for securities firms and banks (such as MHBK) that are direct participants in JASDEC's Book-Entry System. JASDEC is a private-sector company, and its major shareholders include the Japan Exchange Group, the Japan Securities Dealers Association, and several major banks and securities companies. Mizuho Bank also owns a minority stake in the CSD. Securities transactions are processed entirely by electronic book entry transfer between accounts without any physical delivery of securities. All assets are held in the name of the local custodian bank or other participant, not in the name of the client, in accordance with JASDEC rules. However, the local custodian's proprietary assets and customer assets are always held in separate accounts, so that in the unprecedented event of a bankruptcy of a local custodian, creditors would have no claim whatsoever on customer assets. It should also be noted that delivery versus payment (DVP) is carried out by Japan's two clearing houses, and securities settlement is conducted at JASDEC (exception: JGBs are settled at the Bank of Japan), while cash settlement is carried out by the Bank of Japan (see III-B-1 for more information).

JASDEC serves as the depository for the following securities:

- Equities
- Corporate bonds
- Corporate money market instruments
- Beneficiary certificates of ETFs/ETNs
- Preferred investment securities of financial institutions established by cooperative associations
- Investment securities such as REITs listed on a Japanese exchange
- Investment company bonds
- Municipal bonds, government agency bonds, and other special corporation bonds
- Samurai bonds
- Beneficial certificates of investment trusts
- Foreign securities, etc. listed on Japanese exchanges
- Japan depository receipts (JDRs)
- unlisted shares (certain JASDEC eligible shares, please refer to page.7)

All outstanding shares of exchange-traded companies have been held at JASDEC since dematerialization was completed in January 2009. JASDEC also operates the instruction pre-matching facility "Pre-settlement Matching System" (PSMS), which is used for the securities it safekeeps, as well as the Japanese Government Bonds (JGBs) at the BOJ.

2. Bank of Japan (BOJ)

The Bank of Japan (BOJ), Japan's central bank, acts as the central securities depository for JGBs. It conducts the cash settlement and securities transfer for JGB transactions via the BOJ-Net computer system, although matching is generally conducted through JASDEC's pre-settlement matching system. With a few rare exceptions, JGBs are completely dematerialized, and transactions are settled in a dematerialized form on a book-entry basis according to the settlement instructions sent by participants via BOJ-Net.

B. Clearing houses

Two out of three Japanese clearing houses merged on 1 October 2013, and now there are two clearing houses in Japan. They act as counterparties for the settlement of securities and cash. In this capacity, they assume all counterparty risk (i.e., that the seller in a securities trade will not deliver the securities or that the buyer will not pay for them). Since they engage in cash settlement, they maintain current accounts at the BOJ, which is a type of bank account that allows them to transfer money, conduct call trades, and make other settlements with qualified financial institutions (banks, securities companies, etc.) operating in Japan. The CSD JASDEC does not conduct DVP, and

therefore does not maintain a current account at the BOJ.

1. Japan Securities Clearing Corporation (JSCC)

The Japan Securities Clearing Corporation (JSCC) commenced operations in January 2003. JSCC acts as the central counterparty for virtually all spot transactions on all of Japan's securities exchanges, as well as major proprietary trading systems (PTS) and the TOKYO PRO Market. Securities handled include stocks, corporate bonds, ETFs, ETNs, credit default swaps (CDSs), J-REITs, and on and after 1 October 2013, JGB. It also conducts clearing for futures and options for Osaka Exchange, which is the center of derivatives trading in Japan. The JSCC executes settlement procedures for securities trades and cash transfers on behalf of JASDEC on a DVP basis by netting settlements on a cross-exchange basis.

The corporation uses JASDEC's central securities depository and its' Book-Entry Transfer System for securities and makes cash settlements through transfers between a participant account and a JSCC account at either the BOJ or one of six designated banks (MUFG Bank, Ltd.; Sumitomo Mitsui Banking Corporation; Resona Bank, Ltd.; Mizuho Bank, Ltd.; The 77 Bank, Ltd.; Citibank N.A. Tokyo Branch.). Settlements for both cash and securities are netted at the end of each trading day.

It was established by the 5 major securities exchanges in Japan and Japan Securities Dealers Association (JSDA) as a cross-market clearing organization in order to consolidate the clearing functions of securities in Japan.

On 1 October 2013, JSCC acquired Japan Government Bond Clearing Corporation (JGBCC) and became the sole settlement infrastructure for the JGB market for securities companies, banks, and other financial institutions in what is predominantly an over-the-counter market. The JGBCC, which commenced operations in 2005 as a joint venture by securities companies, banks, and other major players in the market for JGBs (NOT by the Bank of Japan itself) continues functioning as a unit of the JSCC in the restructuring of Japanese clearing system. As the JGBCC has done, the JSCC acts as the central counterparty for the settlement of JGB trades and related cash and nets balances at the end of the trading day. In its capacity as the central counterparty, the JSCC also guarantees against the failure to deliver funds or make payment.

On 27 July 2020, Japan Exchange Group (JPX) integrated Japan Commodity Clearing House (JCCH) to JSCC. JCCH has been the clearing house of commodity derivatives products traded at Tokyo Commodity Exchange (TOCOM). On the same day, futures and options trading on precious metals, rubber and agricultural products were transferred from TOCOM to OSE, while energy related products remain traded at TOCOM.

2. JASDEC DVP Clearing Corporation (JDCC)

JASDEC DVP Clearing Corporation (JDCC) was incorporated in June 2003, as a wholly owned subsidiary of JASDEC. Like JSCC, JDCC acts as the central counterparty in securities other than JGBs, but JDCC acts as the central counterparty for "customer-side" transactions directly between two custodians/brokerages (referred to as "non-exchange transaction deliveries" or NETDs on JASDEC's website) rather than "street-side" transactions on the exchanges. As implied by the name, DVP settlement is available at JDCC when participants on both sides (seller and buyer) agree to use DVP, and it is up to participants whether to settle via DVP or non-DVP. Settlements for cash are made on a real-time gross settlement (RTGS) basis, while settlements for securities are netted at the end of the day.

To understand the settlement flow for listed securities in the Japanese market, it is important to take into account that the trade flow involves separate two trade agreements: one between the non-resident securities company and the Japanese securities company, and one between the Japanese securities company and the securities exchange. Consequently, the settlement for each trade must also be conducted twice at JASDEC to reflect the two trades. The trade between the non-resident securities company and the Japanese securities company is settled by JDCC ("customer side") and the trade between the Japanese securities company and the securities exchange is settled by the JSCC ("street side"). Two settlements must be conducted for any trade of exchange-listed securities. Please bear in mind, however, that settlement is not conducted at the JSCC if the trade involves securities—such as most bonds—that are not listed on any exchange.

The diagram below provides a simplified illustration of how the two clearing houses work within the securities settlement system in Japan.

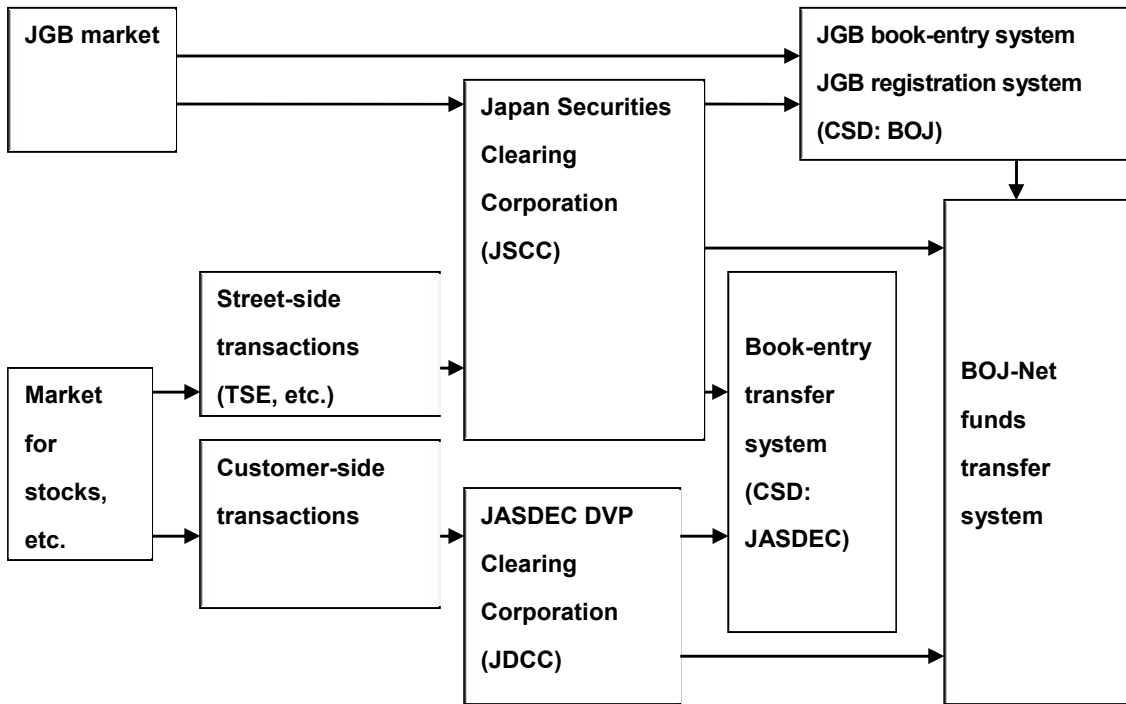

The following diagram offers a more detailed illustration of the flow for clearing in the settlement process involving a non-resident investor in the Japanese market. It also shows the aforementioned two-part trade flow (non-resident brokerage Japanese brokerage and Japanese brokerage securities exchange) and the resulting two-part clearing flow inside of JASDEC for a single trade, once at JSCC and once at JDCC.

Chart III-B-3 (2): Flow of Clearing Houses in Japan’s Securities Settlement System

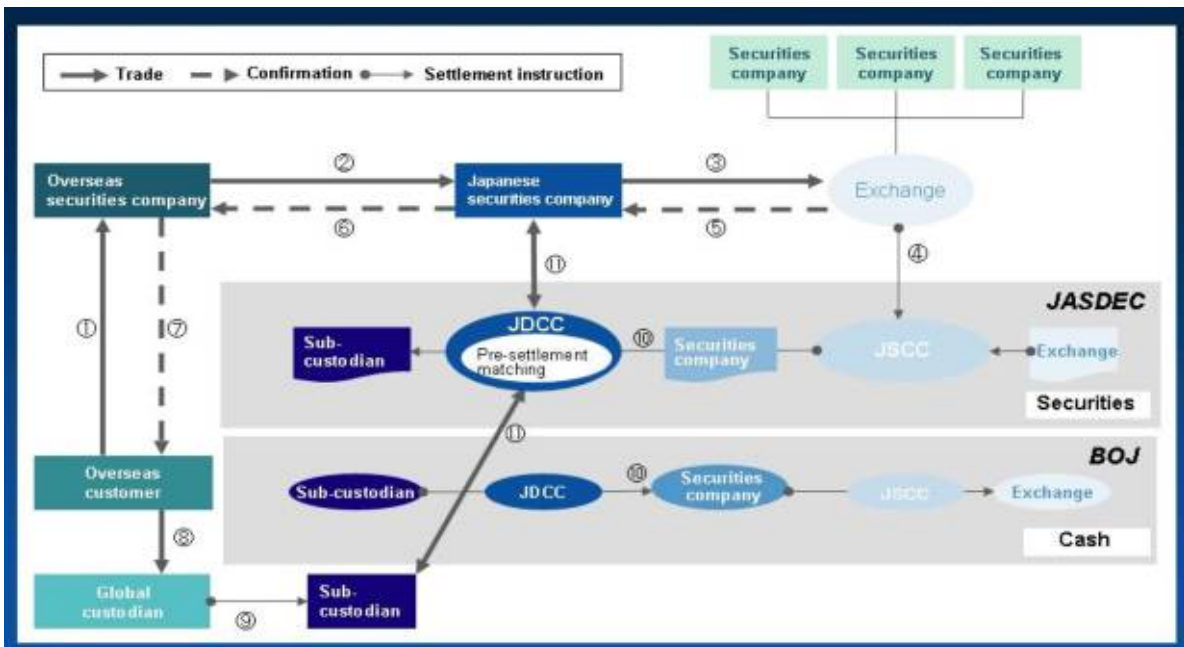

IV. Securities and Cash Settlement

A. Securities settlement system

Settlement infrastructure for (1) JGBs at the BOJ and (2) other book-entry securities at JASDEC are both based on the Act on Book-Entry Transfer of Company Bonds, Shares, etc., and the systems for both are accordingly similar.

1. JGBs at BOJ

JGBs are settled on a real-time delivery versus payment (DVP) basis on the BOJ's JGB Book-Entry System through the Bank of Japan Financial Network System (BOJ-Net) JGB Services (not to be confused with BOJ-Net Funds Transfer System); the BOJ's online system to transfer JGBs between accounts of roughly 300 financial institutions. In addition to the settlement of JGB transactions, the BOJ-Net JGB Services system deals with the auction, issuance, and payments of JGBs at the time of issuance via online processing. The JGB Book-Entry System is subdivided into a three-tiered system under the depository (BOJ). First, directly under the BOJ are its direct participants (entities with JGB a book-entry account at the BOJ). Under the direct participants are indirect participants (Japanese entities with JGB accounts at direct participant to transfer JGBs on behalf of its own clients; status subject to BOJ approval) and foreign indirect participants (indirect participant for customer accounts managed outside of Japan, status subject to BOJ approval). Finally at the bottom are the customers (entities with accounts at indirect/foreign indirect participants, BOJ approval not needed). For direct participants, BOJ announced its plan in April 2017 to allow direct participants that have current account with BOJ to have "Global Access" to BOJ-Net via the BOJ-Net Terminal located outside of Japan, in addition to the access to BOJ-Net through the BOJ-Net Terminals located in Japan. BOJ started accepting the application for such "Global Access" from 14 December 2017. Users of "Global Access" will not be allowed to connect BOJ-Net Terminal with user's intra-network. BOJ has already had CPU-connection capability from abroad if a CCS (Computer-to-computer Connection System) is set up by the user in Japan as a relay system.

Under the ASEAN+3's Asian Bond Markets Initiative (ABMI), initiative to improve cross-border settlement in the region, BOJ announced that BOJ and Hong Kong Monetary Authority (HKMA) would jointly start preparing for the implementation of cross-border DVP link between BOJ-NET JGB Services and HKD CHATS by the end of March 2018. BOJ and HKMA launched its production operation on 1 April 2021.

2. Other securities at JASDEC

Stocks deposited at JASDEC are settled via the Book-Entry System for Stocks, etc. (see link for flow chart: <https://www.jasdec.com/en/system/less/outline/organization/>). The JASDEC Book-Entry System follows the same three-tiered system as the BOJ's, although they use different names (direct account management institution [AMI], indirect account management institution [IAMI], foreign indirect account management institution [FIAMI]). The number of direct account management institutions differs depending on the type of security handled. Like the BOJ's Book-Entry System, only direct account management institutions (such as Mizuho) are connected to send trade instructions to JASDEC's computer system; all indirect participants and their customers submit instructions to the direct participant through SWIFT, which are automatically sent through JASDEC's Book-Entry System to be settled at JASDEC without manual operations (straight-through processing or STP). Manual processing is only necessary when trades do not match due to discrepancies in the instructions of the two parties to the trade, such as the payment amount. In the event that a correction is necessary, Mizuho inputs the amended data either through the JASDEC system or through its own proprietary MACS system. All stocks traded on the exchanges can use DVP. DVP was established for TSE- and OSE-listed securities in 2001. Most non-JGB bonds (municipal, corporate, convertible, and warrant bonds) are also held and settled at JASDEC via the Book-Entry System by DVP.

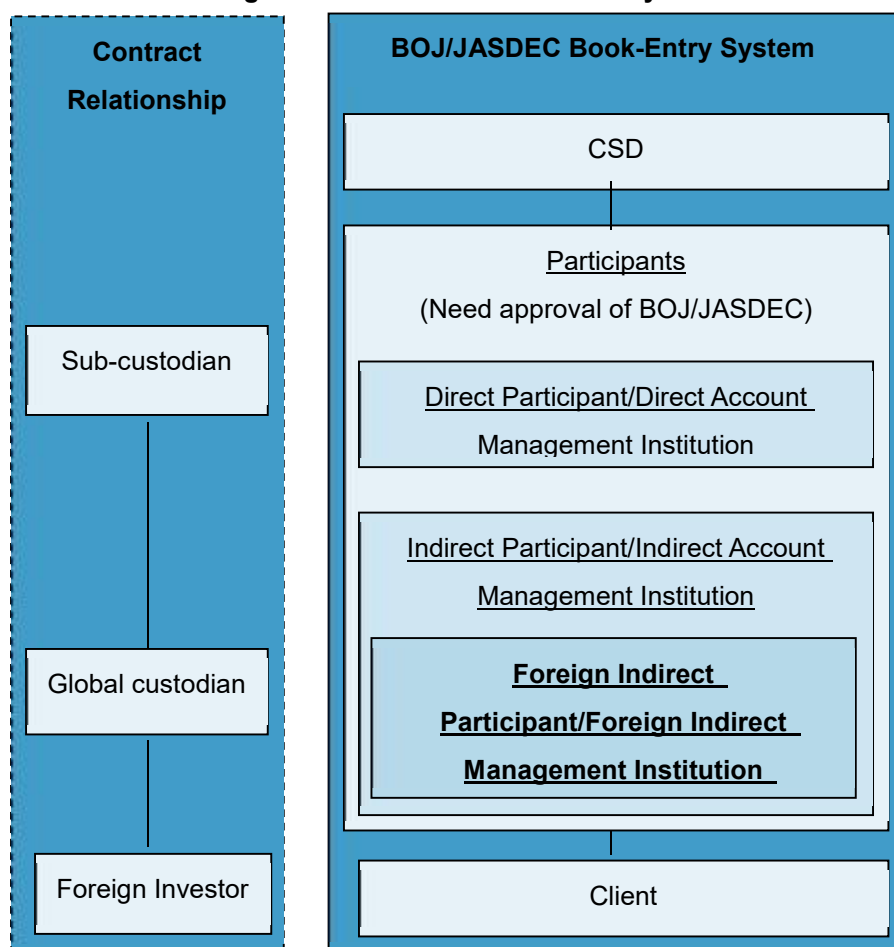
Chart IV-A-2: Linkage from CSD to Final Beneficiary

B. Cash settlement system

1. BOJ-Net Funds Transfer System

The primary function of the Bank of Japan Financial Network System (BOJ-Net) Funds Transfer System is to process transaction data between the BOJ and almost all the major domestic financial institutions, including banks and securities companies, with current accounts at the BOJ and connected to the system (see III-B-1 for more information) through its online network. It is responsible for fund transfers in both cash and derivatives markets, as well as commercial transactions. Please refer to charts under III-B-3 (1) for an illustration of the role of the BOJ in JGB clearing and cash settlement and IV-C-1 (2) for the settlement and reconciliation of JGBs. Please see page 73 of the BOJ's "IV. Payment and Settlement and the Roles of the Bank of Japan" on the BOJ's website (<https://www.boj.or.jp/en/about/outline/data/foboj06.pdf>)

The BOJ settles cash transactions related to securities trading on a real-time basis every business day.

2. Foreign Exchange Yen Clearing System (FXYCS)

The FXYCS is the clearing facility for foreign exchange-related yen cash settlement in Japan. Participating banks exchange payment instructions, and settlement is netted out in banks' current accounts at the Bank of Japan. The Japanese Bankers Association manages the system. FXYCS is used for clearing transactions related to foreign exchange, such as forex dealings, the transfer of yen to or from correspondent accounts, and yen-denominated transfers. FXYCS's payment instructions are processed via BOJ-Net Funds Transfer System.

3. Discussions on the use of CLS in FX transactions

In August 2017, JFSA released the interim report summarizing the discussions and action plan to improve Foreign Exchange (FX) Risk Management of domestic trust accounts. Following “Supervisory guidance for managing settlement risk in foreign exchange transactions” set by Basel Committee on Banking Supervision in 2013, JFSA declared, in its annual financial industry administration policy for business year 2016, to encourage the use of simultaneous settlement over the settlement platform of CLS Bank for the purpose of reducing FX settlement risk.

JFSA focused on transactions of trust accounts in Japan as it saw higher residual risk given the fact that FX transactions by pension funds and investment trusts do not simultaneously settle while FX transaction volume has been growing by 30% in past three years. JFSA formed a roundtable on FX settlement risk (Roundtable) consisted of various domestic FX market players, including trust banks, FX banks, asset managers, global custodians, market infrastructures, and Bank of Japan (BOJ). The suggestion of the Roundtable was to take a phased approach: initial phase (starting from the second half of fiscal 2018); and full-scale phase (from the second half of fiscal 2019 to the first half of fiscal 2020). Transactions to be covered in the initial phase were the ones between domestic trust funds with non-Japanese asset managers and non-Japanese FX banks which generally already users of CLS simultaneous settlement outside of Japan.

C. Securities settlement process

1. Settlement flow for securities traded by non-residents in the Japanese market

Please see the two diagrams below for an illustration of the settlement flow of (1) equities and bonds other than JGBs and (2) JGBs for non-residents in the Japanese market:

Chart IV-C-1 (1): Settlement & reconciliation for equities, non-JGB bonds (JASDEC DVP)

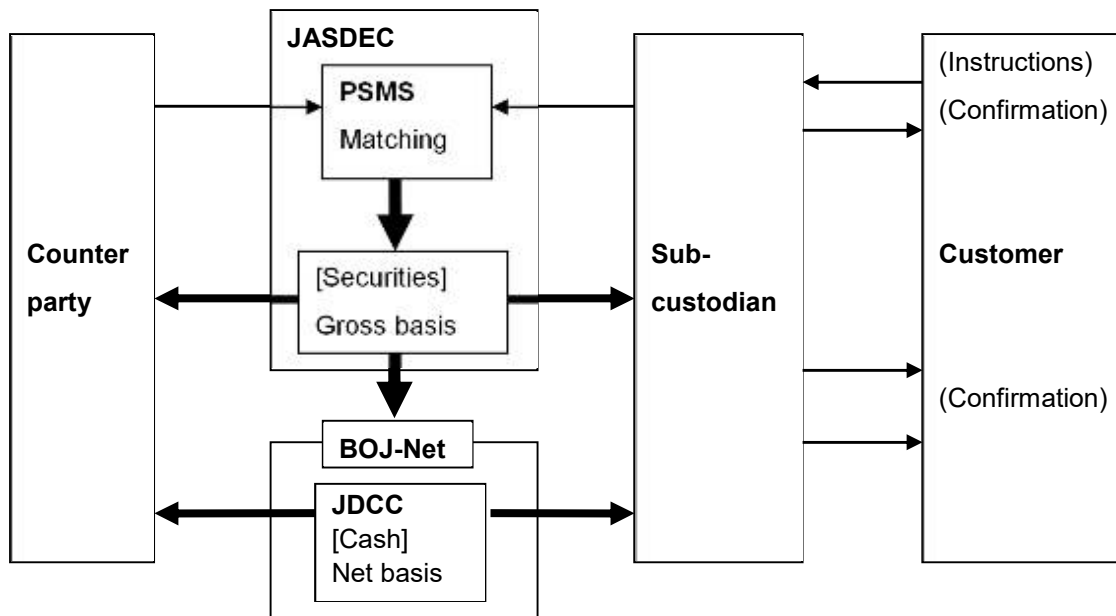
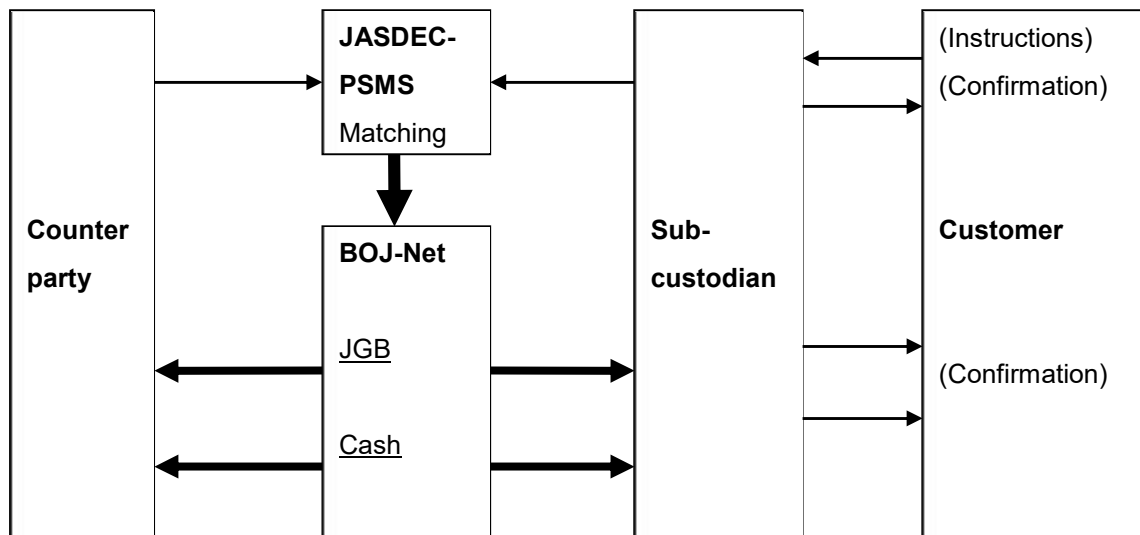

Chart IV-C-1 (2): Settlement & reconciliation for JGBs



2. Settlement cycle for stocks, corporate bonds, municipal bonds, and JGBs

Securities transactions are settled through accounts held by the exchanges and their member companies at JASDEC. For domestic stocks, the settlement of an ordinary transaction is affected under the “rolling settlement” method, and this is also the usual system for corporate bonds and municipal bonds. Since 16 July 2019, the settlement cycle of listed securities has been shortened to the second business day (“T+2”) from the third business day (“T+3”) after the day on which a trading contract is concluded (“T”). For clarification, all securities listed on the exchanges in Japan (except for listed JGBs), excluding OTC trades but including off-auction distributions, fall in the scope of T+2 settlement cycle change of July 2019.

For JGBs, JSDA shortened the settlement cycle from previous T+2 to T+1 on 1 May 2018. JGB trades between residents of Japan traded on or after 1 May 2018 have been settled in T+1 settlement cycle. This changeover does not apply to non-resident investors; however, there are some spillover effects observed in the market, and the settlement fails involving non-residents are reportedly increasing. Prior to the shift to T+1, JSDA made a suggestion to establish operational flows and infrastructures for non-resident investors’ trades to be conducted on T+2 as the standard settlement cycle. Along with its suggestion, JSDA listed up issues to be considered in order to shorten the settlement cycle further to T+1 in future, such as investors’ compliance with the market practice of 5-billion-yen ceiling per trade and participation of more market counterparties to the Pre-settlement Matching System given that pre-matching of JGBs are presently done over telephone if either or both of counterparties do not use JASDEC PSMS.

Ministry of Finance of Japan (MOF) also shortened the settlement cycle of primary market, i.e., newly issued coupon bearing 5- to 30-year JGBs issued in March, June, September, December; were shortened to T+1 from 1 May 2018. Before May 2018, as a general rule, 5- to 30-year JGBs were issued on the 20th regardless of the auction date, if issued in March, June, September, or December. Also, 2-year JGBs were issued on the 15th of every month regardless of the auction date. Other new issuances have been settled in T+2 cycle.

Since 1 May 2018, all of newly issued JGBs, except for 2-year JGBs, have been settled in T+1 cycle based on the auction date. The coupon payment and redemption day in March, June, September, and December remains the same, i.e., 20th of the month. As an exception to this T+1 cycle rule, newly issued 2-year JGBs are settled on 1st day of the following month of auction date, and the above-mentioned new rule commenced to apply to these JGBs bid in the auction in May 2018. In conjunction with this change of settlement cycle in the JGB primary market, redemption cycles are also changed. From 1 May 2018, coupons bearing 5- to 30-year JGBs issued in March, June, September, or December, are redeemed along with 5- to 30-year JGBs issued in previous two months. For example, redemption date of new JGBs issued in June is set in March and redeemed together with the JGBs issued in April and May. Similarly, 5- to 30-year JGBs issued in July, August, and September are redeemed in June.

The following is the table summarizing the old and new rules:

		Settlement Date	
		Before 1 May 2018	From 1 May 2018
Secondary Market		T+2 (two Tokyo banking days following the transaction date)	T+1 (next Tokyo banking day of the transaction date)
Primary Market	General rule	T+2	T+1 (next Tokyo banking day of the auction date)
	5- to 30-year coupon bearing JGBs issued in Mar, Jun, Sep, Dec	20th of the month, regardless of the auction date (if 20th is a Tokyo bank holiday, then the following Tokyo banking day)	T+1 (next Tokyo banking day of the auction date)
	2-year JGBs are issued every month	15th of the following month of the auction date (if 15th is a Tokyo bank holiday, then the following Tokyo banking day)	1st of the following month of the auction date (if 1st is a Tokyo bank holiday, then the following Tokyo banking day)

JSDA also shortened the settlement cycle of the trades of JGBs for retail investors and JASDEC eligible bonds to T+2 from T+3 settlement cycle on 13 July 2020. This changeover does not apply to non-resident investors, and the settlement cycle can be adjusted on bilateral agreement between the trading parties even after the implementation date. It should be noted that (1) for JGBs for retail investors, it is applicable for the sales and redemption before maturity only, and (2) for JASDEC eligible bonds, (i) it is applicable for secondary trades only (primary market is out of scope), and (ii) JSDA will consider providing information to non-resident investors on the settlement matching operations, as is the case with JGB trades, and will continue to pay attention to the progress of shortening the settlement cycle of JGB trades with non-resident investors, and consider implementing to JASDEC eligibility bonds as necessary.

Following the transition to T+1 settlement framework for equities in the North American region from May 2024, market participants in Japan also began to discuss the adoption of T+1. The Financial Services Agency has begun practical discussions with market participants towards the adoption of T+1 settlement cycle for equities, so that Japan's securities settlement system would follow the global movement.

Please see the diagrams below for an illustration of the T+2, and the T+1 settlement cycles. As can be seen from the diagram, entitlement to dividends, etc. is fixed on the day settlement is completed rather than on the day the trade is made. This fact distinguishes Japan from most other developed markets, where entitlement is fixed on the date of the trade.

Chart IV-C-2 (1): JASDEC eligible bonds, JGBs for retail investors (resident investors) → T+2 settlement

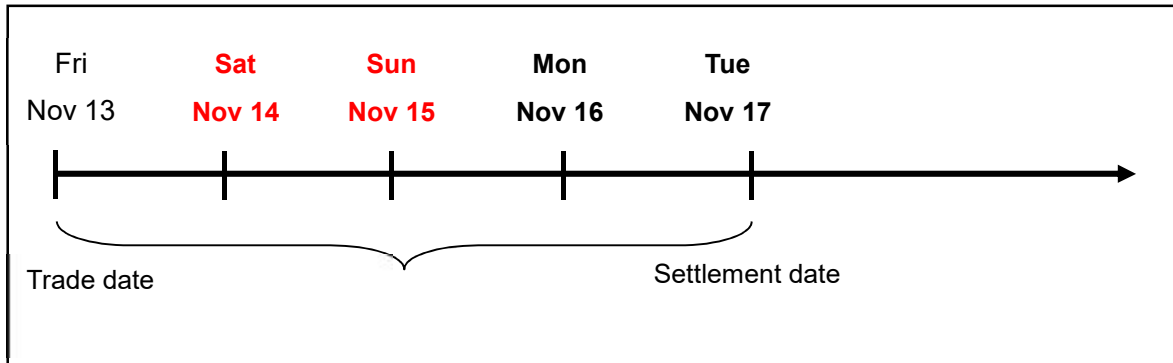

Chart IV-C-2 (2): Exchange-traded listed stocks → T+2 settlement

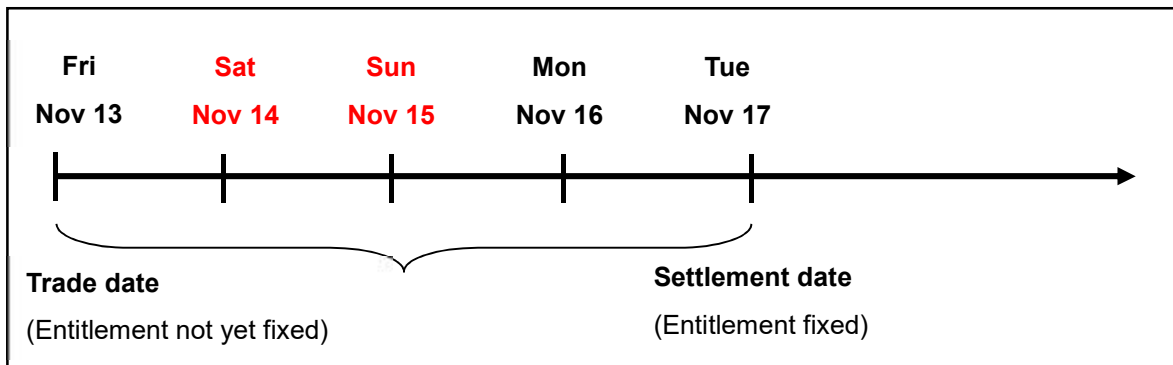
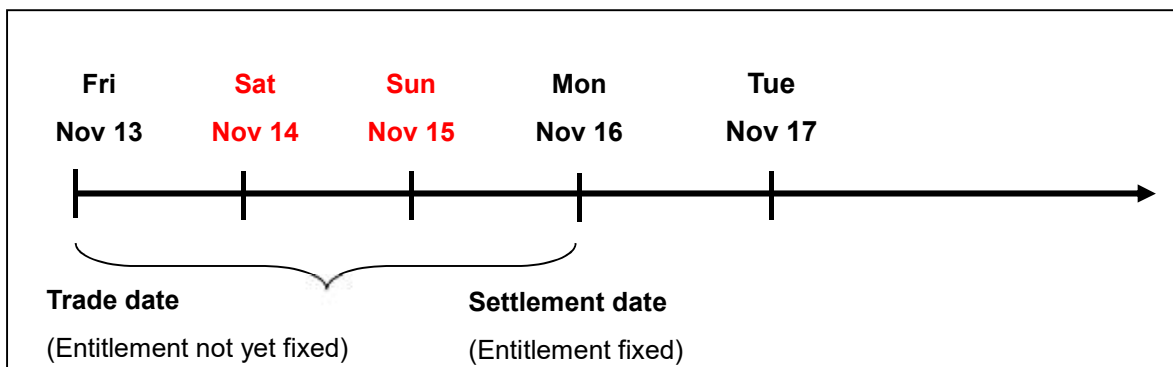

Chart IV-C-2 (3): JGBs (resident investors) → T+1 settlement



3. Settlement workflow between sub-custodian and clients

Based on the infrastructure described above, settlement between a sub-custodian such as Mizuho Bank (MHBK) and its clients typically takes the following workflow.

Chart IV-C-3: Settlement workflow with Mizuho and clients

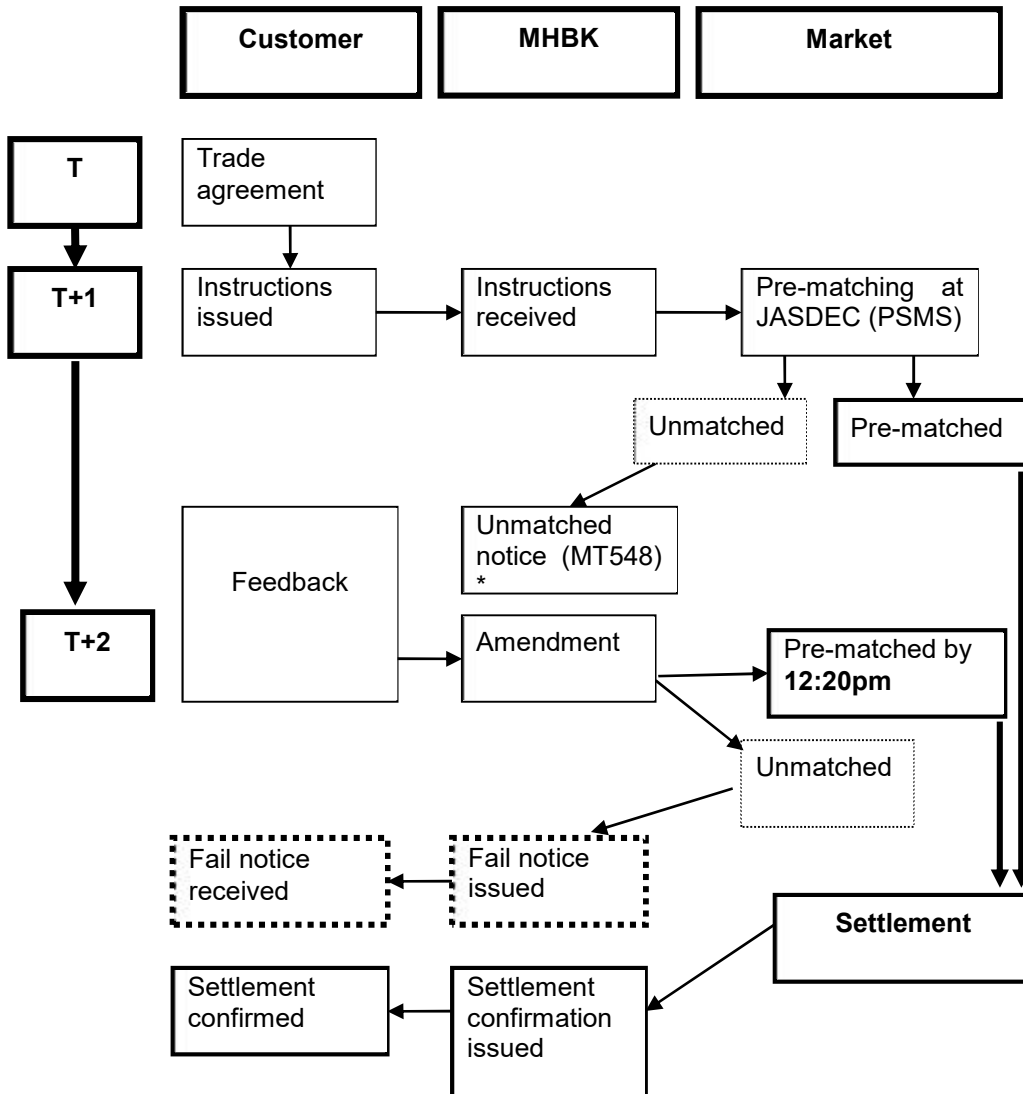

(*) Clients notified of matching status regardless of whether an instruction is matched or not. From 6 January 2014, tolerance matching started to apply to the settlement instructions for any non-resident's transaction with amount discrepancy within JPY100, and the settlement amount could be adjusted up to JPY100 by the automatic settlement amount adjustment by JASDEC PSMS.

As illustrated above, when settlement instructions do not match, the window for instruction amendment is quite small, and may not be possible to confirm the matched status prior to the settlement date. The timeframe becomes even challenging if instructions are sent from US/Europe time zones.

4. Trading and settlement of various securities

Please see below for a comparison of how equities/non-JGB bonds and JGBs are traded and settled.

Equities and non-JGB bonds

- (1) Institutional investor places order with brokerage firm
- (2) Broker executes trade with counterparty at stock exchange and obtains position for its customers via JSCC (street-side trades); all settlements are netted out at clearing house
- (3) Broker forwards instruction (customer-side trade) to JASDEC; custodian bank also forwards instructions from customer to JASDEC.
- (4) Instruction is normally pre-matched via PSMS, JASDEC's pre-matching system
- (5) After pre-matching, instruction is processed at JASDEC, and funds/securities deposited in custodian's account and broker's account at JASDEC accordingly.

JGBs

- (1) Institutional investor places order with brokerage firm.
- (2) Broker executes trades with counterparties over the counter, and obtains position for its customers via JSCC (street-side trades), all settlements are netted out at clearing house
- (3) The broker forwards instruction (customer-side trades) to BOJ; custodian banks also forward instruction from customer to BOJ.
- (4) Instruction is normally also pre-matched via PSMS, JASDEC's pre-matching infrastructure.
- (5) After pre-matching, instruction is processed at BOJ, and proceeds/securities are posted to custodian's account and broker's account at BOJ accordingly.

As mentioned earlier, the dematerialization of exchange-traded equities was completed in January 2009 in Japan. Nearly all JGBs and short-term government debt were already dematerialized in the BOJ-operated clearing and settlement system prior to equities. Other instruments such as publicly traded REITs, ETFs, and corporate bonds are also dematerialized and are processed at JASDEC.

5. Market deadlines

Market deadlines are as shown in the chart below. MHBK's own deadlines are determined via negotiation with each individual client and depend on terms and conditions of the agreement.

Chart IV-C-5: Market deadlines

Security Type	Type of Transaction	Market cut-off time*
Equities	Delivery versus payment	12:20pm
	Receive versus payment	12:20pm
	Deliver Free	12:20pm
	Receipt Free	12:20pm
	Cancellation	8:00 pm on SD-1BD
Fixed income (corporate, municipal bonds, etc.)	Delivery versus payment	2:00pm
	Receipt versus payment	2:00pm
	Deliver Free	2:00pm
	Receive Free	2:00pm
	Cancellation	8:00pm on SD-1BD
Japanese Government Bonds (JGBs)	Delivery versus payment	2:00pm
	Receipt versus payment	2:00pm
	Deliver free	2:00pm**
	Receive free	2:00pm**
	Cancellation	None designated
Cash settlement	Interbank	3:00pm***

*All times listed in chart are expressed in Japan standard time.

**In line with the extension of BOJ-Net's operating hours, the working group that consists of local brokers, trust banks and custodian banks agreed to target to close instruction pre-matching by 7:30pm for free of payment trades

***Assumes cash settlement is conducted bank-to-bank. In the event that the transaction is bank-to-company or vice versa, the market deadline will depend upon the counterparty.

Here, again, please be reminded that the above deadlines for JGBs are market deadlines, and MHBK's own deadlines are determined via negotiation with each individual client and depend on terms and conditions of the agreement.

D. Buy-ins

Buy-ins are the process by which a securities company exercises the option to require the seller in a securities transaction reimburse the broker in the event that the seller fails to deliver the securities on the settlement date or within a certain period following the date. In general, custodians are not involved in the buy-in process. This is because buy-ins take place to clear failed on-exchange trades. In other words, buy-ins are initiated for accounts that brokers have at a clearing house. Since settlements at custody accounts are for off-exchange trades, buy-ins do not occur to accounts that foreign investors have at local custodian banks.

1. Rare in the Japanese market

Buy-ins are extremely rare in the Japanese market, and the country have buy-ins only once in several years. This is because the process is viewed as a last resort to clear up unsettled trades. Unsettled trades are generally the result of missing instructions. In Japan, it is common market practice to solve a delay in delivery between the relevant brokers instead of conducting a buy-in. Consequently, failed trades are usually resolved by the end of the business day following their occurrence.

In the past, a certificate called a “due bill” was used in the Japanese market until the JSCC started acting as the central counterparty for settlements of trades on exchanges. This method was replaced by buy-ins for securities settlement, but it remains an option for delivery failure of limited types of certificates such as stock warrants.

2. Rules governing buy-ins

The rules governing buy-ins in the Japanese market are as follows:

Securities held at JASDEC

a. Parties involved in buy-in:

The Japan Securities Clearing Corporation (JSCC) carries out buy-in processes for securities held at JASDEC. In Japan, broker-dealers typically initiate buy-ins, and custodian banks do not take part in the process.

b. Operational flow of buy-ins:

The basic timing of the various stages of buy-ins for securities at the JSCC is as follows:

Chart IV-D-2: Workflow for buy-ins

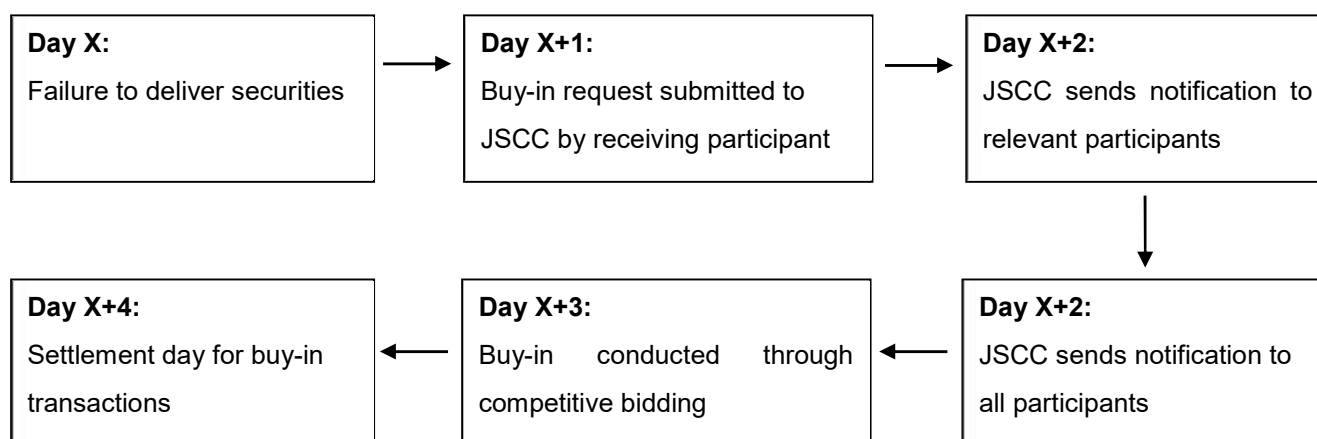

JGBs held in JGB book-entry system

a. Parties involved in buy-ins

The Japan Securities Clearing Corporation (JSCC, the unit formerly known as JGBCC) fulfills the key role in handling the buy-in process for JGBs held in the JGB book-entry system in the Japanese market. As JGB buy-ins are typically initiated by the JSCC or its participants, custodian banks do not take part in the process.

b. Operational flow of buy-in for book-entry JGBs

The process of buy-ins for JGBs held in the JGB book-entry system could be different from the process for other securities at the JSCC. The operational flow for buy-ins is governed by a number of general rules. The BOJ defines buy-ins as "a procedure for settling a failed transaction, including (i) a purchase of either the same or equivalent securities from the market in accordance with "regulations concerning resolution of fails in bonds, etc. settlements" set by the JSDA, and (ii) a purchase of JGBs by the JSCC or its participants in accordance with the rules set by the JSCC".

c. The main rules for JGB settlement

i. Buy-ins governed by the rule of the JSCC:

The same rule applicable to the securities held at JASDEC applies to JGBs.

ii. Buy-ins governed by the rule of the JSDA:

- A buy-in notification is issued to the delivering JSDA member if a trade remains unsettled on the tenth business day following the settlement date.
- A buy-in notification should be issued by noon on the tenth day prior to the day the buy-in is scheduled to be carried out.
- If the buy-in is not carried out on the scheduled day, and settlement cannot be carried out for the failed trade by the noon of the following day, the receiving JSDA member can initiate a buy-in.
- If the buy-in is not carried out by the third day after its scheduled execution, the buy-in notification shall be voided.

E. Market practice for failed JGB trades

Japan's market practice for failed JGB trades makes it possible for the receiving party in a failed JGB trade to claim payment of a "fail charge" from the delivering party, provided both parties have already given advance notice to their counterparties of their intention to adopt the "fail charge" market practice.

Chart IV-E: Summary of the "fail charge" practice in Japan

Introduction	1 November 2010
Background	Modeled on US Treasury Market Practices Group's Fails Charge Market Practice. Developed by Japan Securities Dealers Association (JSDA) working group with major, non-Japanese securities companies as core members. Practice intended to provide economic rationality to efforts to prevent fails even in a low-interest rate environment.
Definition of fail	A situation in which a party receiving JGBs has not received delivery of the JGBs from the delivering party by the end of the scheduled settlement date based on DVP/against settlement.
Scope of charges	All market participants executing purchase/sale transactions and repo transactions in JGBs are expected to comply. Applies to non-residents if so agreed between trading parties. A claim for a fail charge is issued by the receiving party suffering from the fail against the delivering party failing to deliver the securities.
Degree of compulsoriness	Parties to a transaction are not prevented from acting in another manner if so, agreed by both parties.
Mutual agreement and prior notice	To legally introduce and execute a fail charge into force, all parties of a transaction must agree on its use. To reach an agreement, each market participant should provide advance notice of the fail charge policy to each counterparty.
Amount of charge and payment	Amount of charge calculated for each applicable transaction according to same formula, as defined in the JSDA guidelines. Total monthly amount calculated and claimed on monthly basis by the receiving party in the transaction.
Further information	Please see JSDA's website for more information: https://market.jsda.or.jp/shijyo/saiken/kessai/rtgs/rtgs/files/20130529_shishin_e.pdf

Please take note that since fail charges are resolved directly between parties to a transaction, custodian banks are generally not involved in the process.

Further, JSDA announced to implement fail charges for corporate bonds effective from 1 December 2022. The key changes are as follows.

- Fail charges for corporate bonds will be in line with that for JGBs
- Fail charges will also be applied to repo transactions
- Cut-off time for corporate bonds will be changed to 2:00pm to be in line with that for JGBs
- Fail charges rules should be agreed in advance between trading parties.

F. Other points of consideration

Same-day turnaround trade

Same-day turnaround trade is possible in the Japanese market.

Availability of sales proceeds

Proceeds from sales of securities are available on the same day in the Japanese market.

V. Settlement Finality and Registration

The settlement of securities deemed final, and subsequently registered, depending on the type of security as follows:

A. Equities held at JASDEC

1. When a new account is opened, the data of each beneficial owner is sent to the registrar in electronic form.
2. Pursuant to the relevant clause of the Act on Book Entry of Corporate Bonds and Shares, settlement is legally deemed completed and final when the book held by account management institution is updated to increase the holding amount in accordance with instruction.
3. For dividends, as soon as practicably possible after the record date (31 March and 30 September at most companies), custodian banks send the data related to beneficial ownership (information about the holding balance) to JASDEC in electronic form. That is then transferred to the registrars. At this point, the owner is eligible to automatically receive dividends and other payments.
4. Registrars process the registration based on the information from JASDEC. In most cases, trust banks act as registrars (transfer agents).

B. JGBs in Book-Entry form

1. Pursuant to the relevant clause of the Act on Book Entry of Corporate Bonds and Shares, settlement is legally deemed completed and final when the book held by account management institution is updated to increase the holding amount in accordance with instruction.
2. It should be noted that after 3pm of one business day prior to the coupon date or redemption date is a frozen period during which it is not possible to settle. (Note: Frozen period was abolished since 13 October 2015, and JGBs are settled until 3pm of one business day prior to interest payment and redemption day, only if such JGBs' interest payment or redemption takes place on that day.)
3. Ownership is confirmed on the local custodian banks' records on beneficial owners.

C. Bonds held at JASDEC

1. Pursuant to the relevant clause of the Act on Book Entry of Corporate Bonds and Shares, settlement is legally deemed completed and final when the book held by account management institution is updated to increase the holding amount in accordance with instruction.
2. It should be noted that one business day prior to the coupon date or the redemption date is a frozen period during which time the bond cannot be traded.
3. One business day prior to the coupon date, the custodian banks transmit the holders' tax status data to JASDEC.

D. Physical security certificates (unlisted shares, old long-term bonds only)

1. Settlement is completed when physical securities certificates are delivered to custodian.
2. Custodians submit the certificates to the registrar with the re-registration request. Legally, the certificates are deemed to be registered on the day the registrar receives them. At this point, entitlement is fixed.
3. The registrar processes the certificates on request.
4. The registrar returns the certificates to the Custodian bank.

Note: All stock certificates of listed companies have been dematerialized since January 2009. Stock trades in physical form exist only for unlisted equities, long-term bonds issued prior to dematerialization, and other exceptional situations.

VI. Regulations

A. Foreign investment regulations

Like in many other countries, there are certain laws in Japan restricting foreign ownership in some companies for matters of national security or political reasons. The extent of the limitation depends on the industry. There are currently 16 listed companies subject to FOL regulations.

Chart VI-A-1: Companies subject to FOL regulations

Issuer	ISIN code	Industry limit (FOL)	Legal basis
Fuji Media Holdings, Inc.	JP3819400007	One-fifth (20%)	Broadcast Law/ Radio Law
WOWOW Inc.	JP3990770004		
TBS Holdings, Inc.	JP3588600001		
Chubu-Nippon Broadcasting Co., Ltd.	JP3527000008		
Nippon Television Holdings, Inc.	JP3732200005		
Asahi Broadcasting Group Holdings Corporation	JP3116800008		
RKB Mainichi Holdings Corporation	JP3100400005		
BSN Media Holdings, Inc.	JP3656400003		
TV Asahi Holdings Corporation	JP3429000007		
TV Tokyo Holdings Corporation	JP3547060008		
Nippon BS Broadcasting Corporation	JP3746000003		
Nippon Telegraph and Telephone Corporation (NTT)	JP3735400008	One-third (33.3%)	NTT Law
ANA Holdings Inc.	JP3429800000	One-third (33.3%)	Civil Aeronautics Act
Japan Airlines Co., Ltd.	JP3705200008		
Star Flyer Inc.	JP3399320005		
Skymark Airlines Inc.	JP3396000006		

Foreign investors can buy and hold shares even when the foreign ownership ratio is above the limit, but registration of the portion above the limit will be rejected as a limit on voting and other shareholder rights, including the receipt of dividend payments.

As the exception to the above general rule, as of 14 July 2015, Fuji Media Holdings, Inc. (Fuji TV) and Japan Airlines Co., Ltd. pay out dividends to foreign shareholders in accordance with the actual holding even when the foreign ownership exceeds the statutory industry limit although voting rights cannot be exercised beyond the limit.

In 2017, the two broadcasting companies with direct foreign ownership above FOL, i.e., Fuji TV and Nippon TV, announced the change made in their calculation method of FOL under the Broadcasting Act, in their statutory public notices as to the ratio of foreign holders within total voting power. From the record date at the end of September 2017 to the case of Fuji TV, and from the record date at the end of December 2017 for the case of Nippon TV, they changed the calculation method for total voting rights to calculate FOL. To be exact, they started deducting the number of voting rights owned by foreigners which had been rejected for recording on shareholder register when those foreign shareholders acquired the shares of those issuers from the total number of voting rights when calculating the basis of the total voting rights for the purpose of FOL.

According to those media companies, such change was made in accordance with the official notice issued by the

supervisory governmental agency, the Ministry of Internal Affairs and Communications, dated as of 25 September 2017. As the result of such change in calculation method of FOL, existing foreign shareholders on the record may also be subject to the possible reduction of rights to corporate actions, such as dividend payment (in the case of Nippon TV) and voting. A breach of the FOL under the Broadcasting Act will result in the revocation of broadcasting license, and therefore those media companies are authorized to exercise their power to reject recording into shareholder register and to limit the exercise of voting power by foreigners under the Broadcasting Act. According to the government officials with jurisdiction over those broadcasting companies, the official notice was issued for clarification purpose to encourage those issuers' due observation of the intention and policy of the Broadcasting Act.

In February 2024, Nippon TV announced an amendment of their Articles of Incorporation on dividend payments to foreign shareholders in accordance with the actual holding, which was approved at the AGM held in June 2024. Foreign shareholders became eligible for dividends from those with reference date of March 31, 2024, but not for other entitlements.

In April 2024, TV Asahi Holdings Corporation also announced an amendment of their Articles of Incorporation on dividend payments to foreign shareholders in accordance with the actual holding, which was also approved at the AGM in June 2024. The amendment became effective from September 1, 2024.

Chart VI-A-2: Calculation formula of FOL under the Broadcasting Act

$$20\% > B / (A - C)$$

- A: The total number of shares held by all investors
- B: The total number of shares with rights held by foreign investors
- C: The total number of shares without rights held by foreign investors
- D (= B + C): The total number of shares held by all foreign investors

Chart VI-A-3: FOL under the Broadcasting Act (Before and after September 2017)

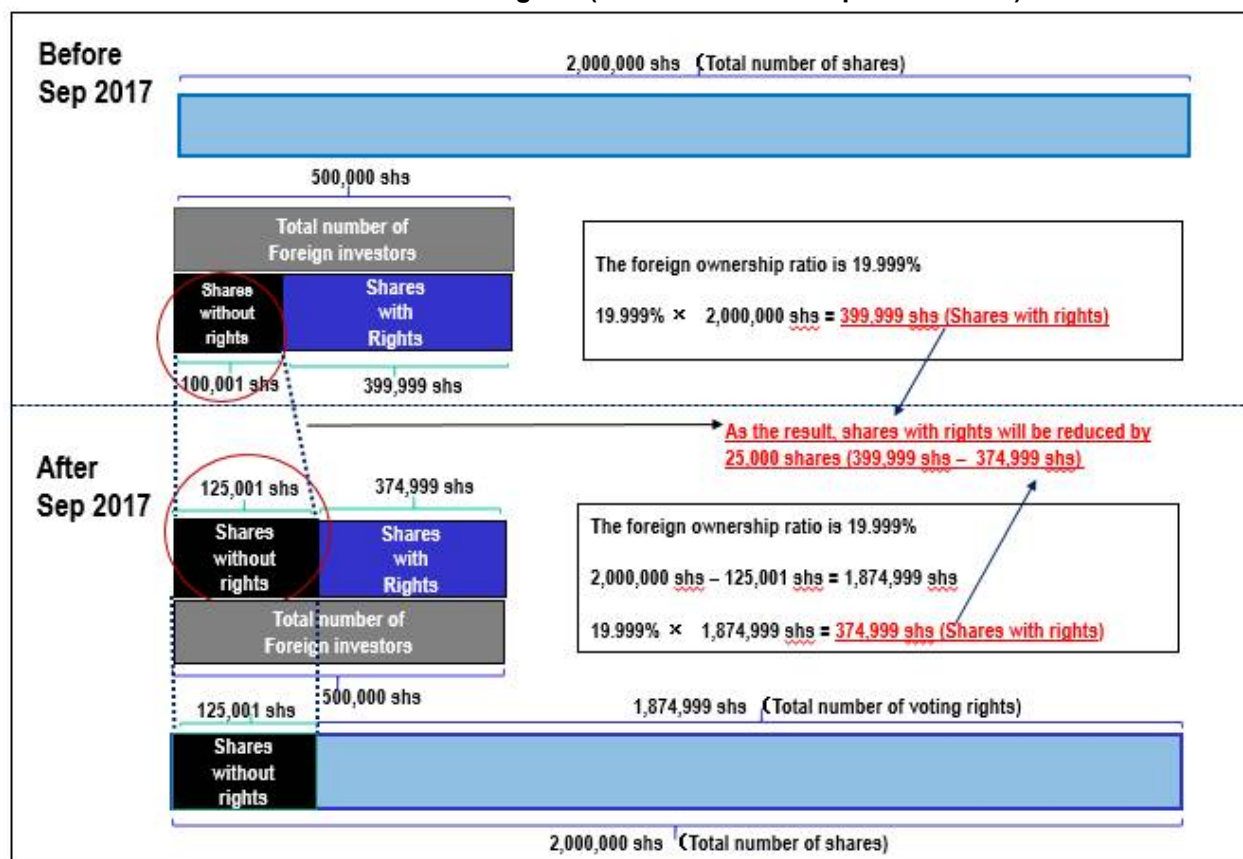

B. Large shareholdings reporting requirement

1. Requirements

Domestic legislation requires both foreign and domestic investors to file certain documents to the Financial Services Agency when their shareholding ratio of a listed company reaches or exceeds 5% of the total number of the company's outstanding shares. In the case of global custodians, large shareholding reporting requirements are based on the stakeholdings of final beneficiaries. Preferred shares and other equity instruments that do not confer voting rights are exempt from this rule.

The documents should state the percentage of the holdings, the purpose of the investment and other relevant facts. The filing must be done within five business days of the investor's holding ratio reaching 5% after the trade date, not the settlement date. In addition, major shareholders must submit a report within five business days when their holding ratio of the company increases or decreases by more than 1% due to the purchase or sale of shares, or if there are any significant changes to information included in the original report. Disclosure is not required for a change in the weighting of shareholdings caused by share repurchases or the issuance of new shares.

This reporting requirement provides a less rigid rule for institutional investors requiring them to report on a specific base date. Investors may select from the two following options for the disclosure date.

- (a) The second and fourth (and fifth) Monday of every month
- (b) 15th day of the month and the month-end

Note: As mentioned above, these ratios are calculated from the trade date, not from the settlement date. Please also note that investors are responsible for filing these reports to the Financial Services Agency, which can be completed on the Internet and do not require any special software.

On May 1, 2026, the amended Financial Instruments and Exchange Act will come into effect, and the rules of the large shareholdings reporting system will be revised. The revised system will be applied to the reporting of large shareholdings of share certificates, etc., which will become mandatory on and after May 1, 2026. Under the amendment, the scope of joint holders and significant proposal activities will be clarified, and the items to be included in the report will also be specified.

While spousal relationships will be excluded from the category of deemed joint holders, relationships such as concurrent directorships will be added. If there are joint holders who have an agreement with the principal to acquire or transfer shares or exercise voting rights together, their holdings will be aggregated to determine whether the total exceeds 5%. When engaging in significant proposal activities, it will be necessary to describe the details, timing, conditions, purpose, and other relevant information as specifically as possible. Furthermore, more detailed disclosure will be required in sections such as "Purpose of Holding." If a decision is made to increase the shareholding ratio by more than 5%, or if such an increase is planned within three months, the timing, acquisition price, quantity, purpose, method of acquisition, and other relevant information must be specified in the "Purpose of Holding" section.

2. Penalties

Japanese law stipulates that the failure to comply with this reporting requirement can be punished with a fine of up to JPY5 million, a prison sentence of up to five years, or a combination of the two. This, however, has proven to be cumbersome way to punish violators, since such stiff penalties require enormous costs in terms of time, money, and manpower to prosecute cases in criminal courts. As an alternative to criminal prosecution, the government instituted a supplementary system of fines for violations of the large shareholdings reporting requirements in December 2008. The outline of the system is as follows.

Amount of fine

The charge is set at 1/100,000 of the total market value of the outstanding shares that are subject to the large shareholdings report.

Note: Currently, the Financial Services Agency is considering raising the amount of fine in order to strengthen

enforcement.

Scope of fine

A fine is issued in the following cases:

- Failure to submit a large shareholding report and/or a change report pertaining to a large shareholding report in a timely manner.
- Submitting (1) a large shareholding report, (2) a change report pertaining to a large shareholding report, or (3) an amendment report on (1) or (2), which contains false statements on significant matters and/or omits important information.

Adjustments to fine

In the case that the shareholder fails to submit a large shareholding report and/or a change report pertaining to a large shareholding report, the fine is reduced by half in the following cases:

- If the shareholder reports the oversight to the Securities and Exchange Surveillance Commission (SESC) before the administrative order on submission of reports is issued.
- If the shareholder reports the oversight to the SESC before the inspection begins.

Conversely, the system also allows for fines to be increased for repeat offenders.

C. Restrictions on direct inward investment stipulated by the Foreign Exchange & Foreign Trade Act

< The original concept >

The Foreign Exchange and Foreign Trade Act (FEFTA) principally support free trade; however, within the scope of international investment rules as defined by OECD guidance, FEFTA requires prior notification for certain types of transactions and actions by foreign investors, such as inward direct investment in specific business sectors. These regulations are implemented from the viewpoint of ensuring national security, maintaining public order, protecting public safety, and ensuring the smooth operation of the Japanese economy, while upholding the principle of freedom of foreign transactions.

< Foreign Investment Screening System >

Under what is commonly referred to as the prior-notification requirement, the Foreign Exchange and Foreign Trade Act (FEFTA) oblige foreign investors to submit advance reports to the Minister of Finance and other relevant ministers responsible for the designated business sectors when making direct inward investments in those sectors ("Designated Business Sectors"). For sectors not specified as designated, reports should be submitted after the investment has been made.

- a. Business sectors to which direct inward investment is restricted due to considerations of national security, public order, or public safety (within the scope of OECD guidance)

Sectors related to national security

- Manufacturers engaged in weapons, aircraft, atomic energy, and space development.

Sectors related to public order

- Infrastructure businesses such as electricity, gas, energy supply, communications, broadcasting, water service, and railway and transportation

Sectors related to public safety

- Biological medicine manufacturers and security guard businesses

- b. Business sectors believed to be adversely affected by foreign direct investment (for which Japan has made reservations pursuant to OECD regulations)

- Agriculture, forestry, fishery, petroleum, leather-manufacturing, airlines, and shipping

< Types of Foreign Direct Investment >

Foreign Direct Investment subject to prior notification is (i) acquisition of 1% or more of the total outstanding shares of a listed company, (ii) acquisition of 1% or more of the total voting rights of a listed company, (iii) Acquisition of shares or equity in an unlisted company, (iv) Transfer of shares or equity in an unlisted company by a non-resident who was formerly a resident. When an equity stake is calculated, a foreign investor’s stake is added to those of a closely related person of the investor.

< Designated Business Sectors >

While upholding the principle of free foreign transactions, the foreign investment screening system under FEFTA designates business sectors—classified as core and non-core designated business sectors—where inward direct investment by foreign investors is subject to prior notification in certain cases, from the perspective of national security and other objectives outlined in FEFTA.

Designated business sectors are specified in public notices issued by the Ministry of Finance and other ministries responsible for each sector and are regularly updated to address evolving economic security requirements within the framework of the foreign investment screening system. In line with this policy, new core designated business sectors have been introduced to ensure stable supply chains and to mitigate risks related to technology leakage and the military diversion of commercial technologies. This follows the designation of "specified critical products" subject to stable supply support under the Act on the Promotion of Ensuring National Security through Integrated Implementation of Economic Measures (the “Economic Security Promotion Act”) in April 2023 and August 2024. The current list of core and other designated business sectors is as follows:

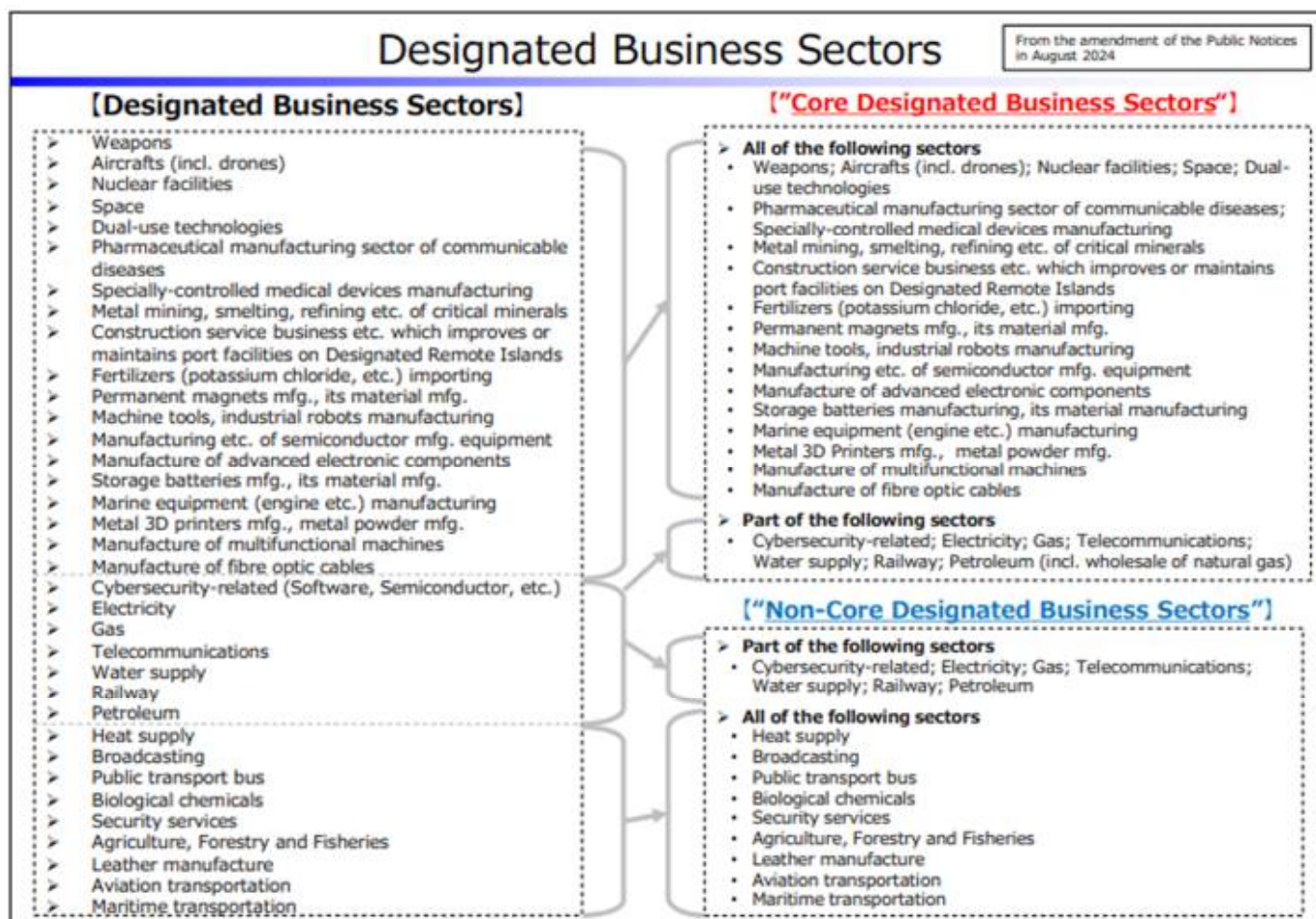

Source: Ministry of Finance

< Prior Notification Exemption System >

Prior notification may not be required for foreign investors when acquiring shares or voting rights in listed companies, or shares and equity in unlisted companies, as part of inward direct investment transactions, provided that certain exemption conditions are met—such as refraining from accepting director appointments and not accessing confidential, non-public technological information. The exemption scheme for Prior-notification of Stock Purchases (PN-SP) of listed companies are as below:

Chart VI-C: Summary of the amended reporting requirement

Type of Investors	Scope	
Foreign Financial Institutions	Non-Core Sectors	< Blanket exemption > - PN-SP will be exempted with no upper limit for investors that comply with the Exemption Conditions (a), (b), (c) below
	Core Sectors	- Post-investment report – from 10%
General Investors (including SWFs and public pension funds accredited by the authorities)	Non-Core Sectors	< Regular exemption > - PN-SP will be exempted with no upper limit for investors that comply with the Exemption Conditions (a), (b), (c) below - Post-investment report – from 1%
	Core Sectors	- PN-SP will be exempted under 10% for investors that also comply with the Exemption Conditions on Core Sectors' Business Activities (a) to(e) below - Post-investment report – from 1%
Type-B investors	Non-Core Sectors	- PN-SP will be exempted with no upper limit for investors that comply with the Exemption Conditions (a), (b),(c) below - Post-investment report – from 1%
	Core-Sectors (other than Designated Core Business Entities)	- PN-SP will be exempted under 10% for investors that also comply with the Exemption Conditions on Type-B investors (a) to (g) below - Post-investment report – from 1%
	Designated Core Business Entities	- No exemption is applicable
<ul style="list-style-type: none"> - Investors with a record of sanction due to violation of the FEFTA State-owned enterprises (except those who are accredited by the authorities) - Type-A investors 	Non-Core Sectors	- No exemption is applicable
	Core Sectors	

Source: Ministry of Finance; compiled by Mizuho.

Exemption Conditions
(a) Investors or their related persons will not become board members of the investee company. (b) Investors will not propose to the general shareholders' meeting transfer or disposition of investee company's business activities in the designated business sectors. (c) Investors will not access non-public information about the investee company's technology in relation with business activities in the designated business sectors.
Exemption Conditions on Core Sectors' Business Activities (in addition to all the above conditions)
(d) Regarding business activities in core sectors, investors will not attend the investee companies' executive board or committees that make important decisions in these activities. (e) Regarding business activities in core sectors, investor will not make proposals, in a written form, to the executive board of the investee companies or board members requiring their responses and/or actions by certain deadlines.
Exemption Conditions on Type-B investors (in addition to all the above conditions)
(f) Investors will not access non-publicised information about the core business sector (excluding information about board members and the financial conditions of investee companies) (g) investors will not send their own employees to investee companies, nor will they recruit or solicit executives or employees of investee companies

Source: Ministry of Finance; compiled by Mizuho.

< Amendments to Cabinet Order and Ministerial Order >

Under the previous prior notification exemption system, foreign governments and state-owned enterprises under their control, as well as individuals or entities previously penalized for violating FEFTA, were prohibited from utilizing the exemption for inward direct investment in all designated business sectors, due to the higher security risks they posed compared to ordinary investors.

Conversely, there are increasing security concerns, such as the risk of foreign investors leaking technology and information from Japanese companies through investments, as well as the potential harm to industries and services related to national security. In this context, it was noted that some investors eligible for the prior notification exemption could invest without pre-screening by authorities, despite posing risks similar to those of foreign governments or state-owned enterprises and potentially leaking sensitive information. To address these concerns, amendments to the relevant Cabinet Order and Ministerial Order were made in April 2025 to revise the application of the exemption system, and these changes came into effect in May 2025.

Specifically, Type-A Investors—those who are obligated to cooperate with foreign governments in collecting information related to Japan's national security under agreements or legal regulations—are now required to submit a prior notification when investing in any designated business sector.

Furthermore, even if an investment does not fall under the aforementioned categories, investments by Type-B Investors in companies subject to the Economic Security Promotion Act that require special measures under FEFTA—specifically, "Specified Essential Infrastructure Service Providers" operating in core business sectors (referred to as "Designated Core Business Entities" under the amended exemption system)—are not eligible for exemption, as they are considered to pose a high risk to national security.

Type-B investors are foreign investors who are considered to pose national security risks due to their substantive decision-making being controlled by Type-A investors, having substantive headquarters in countries or regions where laws on information collection related to Japan's national security apply, or having obligations to cooperate with foreign governments based on agreements with Type-A investors.

The revised Exemption Scheme effective from May 19, 2025, is as below.

Revised Exemption Scheme for Prior-notification Requirement

<In case of acquisition of listed shares> (in red: to be newly introduced this time)

Investee's business	Types of investors	Foreign financial institutions (subject to regulations/ supervisions under financial regulatory laws in Japan or other jurisdictions)	General investors (including SWFs and PPFs accredited by the authorities)	Type-B investors (New category)	Investors with a sanctions record due to violation of FEFTA -SOEs and Foreign governments -Type-A investors
As for the shares of a listed company, prior-notification is required for acquisition of 1% or more of shares	Non-Core Designated Business Sectors	Exemption of prior-notification applicable only when complying with exemption conditions			Prior-notification required *Exemption NOT applicable
	Core sectors	(Less than 10%) Exemption conditions + additional conditions on Core Sectors' Business Activities	(Less than 10%) Exemption applicable only when complying with exemption conditions + additional exemption conditions on Core Sectors' Business Activities +New Additional Conditions for Type-B investors	(10% or more) Prior-notification required *Exemption NOT applicable	
	Designated Core Business Entities (New category)	Prior-notification required *Exemption NOT applicable			

<In case of acquisition of unlisted shares> Prior notification has been required for all investors acquiring shares in core sectors under the current system. This amendment categorise Type-A investors as those who cannot use the prior notification exemption scheme, as in the case of listed shares, and prior notification is also required for the acquisition of unlisted shares in non-core designated sectors.

Source: Ministry of Finance

< List of Classifications of Listed Companies >

For listed companies, the Ministry of Finance periodically reviews and discloses a list on its website to make the category of listed companies under the FEFTA available. The list sets forth the classification of each listed company under the FEFTA as follows: (i) companies conducting business activities only in non-designated business sectors (subject to post-investment report only); (ii) companies conducting business activities in designated business sectors other than core sectors; (iii) companies conducting business activities in core sectors;(iv) Companies which fall under (iii) above, and are also designated as 'Specified Essential Infrastructure Service Providers' as of 14 July 2025 under the Economic Security Promotion Act (so-called 'Designated Core Business Entities' under FEFTA) The list is available from below website:

https://www.mof.go.jp/english/policy/international_policy/fdi/Related_Guidance_and_Documents/index.html

Under the amended FEFTA, the following types of entities are regarded as foreign investors:

- i. Individuals who are not residents of Japan.
- ii. Corporations, etc. established under the laws of a foreign country or domiciled at a foreign country.
- iii. Companies in which the sum of the voting rights directly or indirectly owned 50% or more by above i or ii.
- iv. Corporations, etc. in Japan in which the majority of executives or executives with the authority to represent the corporation are non-residents as defined in above.

Note: As five years have passed since the amendment of the Foreign Exchange and Foreign Trade Act came into effect in 2020, the government is moving to review the Foreign Investment Screening System from the perspective of ensuring the effectiveness of the current framework based on its implementation status and responding to risks in light of changes in the security environment. Specifically, in addition to clarifying procedures related to risk mitigation measures, the government is considering strengthening regulations in cases such as the indirect acquisition of shares or voting rights of Japanese companies, investment activities under the control or influence of foreign governments, and situations where risks to national security materialize as a result of investments in non-designated industries.

VII. Taxation

A. General taxation treatment of non-residents

1. Applicable tax rates

Chart VII-A-1: Applicable tax rates applicable on dividend and coupon income

		Listed equities (dividend)	Non-listed equities (dividend)	Bonds (coupon)
Resident	Individual	20.315%	20.42%	20.315%
	Corporate	15.315%	20.42%	15.315%
	Designated Financial Institution	15.315%	20.42%	0%
Non-resident		15.315%	20.42%	15.315%

Note: The above table does not take double tax treaties into consideration.

*The statutory rate of 20.315% for residents (including 5% local inhabitants' tax applicable to individual retail investors) and 15.315% for non-residents have been reinstated on 1 January 2014 on a pay date basis NOT a record date basis from the temporarily reduced rate for dividends on listed equities of 10.147% for residents (including 3% local inhabitants' tax) and 7.147% for non-residents. The national tax rate of 15.315% includes the increased portion of the Special Income Tax for Reconstruction (0.315%, which is 2.1% of the total income tax) that has been in effect since January 2013. In addition, the establishment of a new Special Income Tax for Defense (provisional) is currently under consideration in the Diet. If it is introduced from January 2027, the Special Income Tax for Reconstruction will be reduced to 0.165% (1.1% of the total income tax), while the Special Income Tax for Defense of 0.15% (1.0% of the total income tax) will be included instead. The expiration date for the Special Income Tax for Reconstruction is scheduled to be extended from December 2037 to December 2047, while the expiration date for the Special Income Tax for Defense remains undecided.

2. Capital gains tax

For non-residents with no permanent establishment (PE) in Japan, no tax is levied on capital gains in principle.

B. Securing tax relief for non-residents on DTTs

1. Function of DTTs

Japan has entered into tax treaties with a number of countries to avoid double taxation of income obtained overseas and prevent tax evasion. In cases for which dividend or interest income tax breaks are provided, eligible classes of investors will need to submit documents related to tax procedures on tax conventions. Upon expiration of the special dividend tax break on 31 December 2013, the government simplified the double tax treaty (DTT) application procedures (see VII-A-1 for more information). Specifically, it reduced the frequency of the submission of a certificate of residency (COR) by pension funds, US publicly traded companies, US public services organization, US governmental entities, and US individuals from 1 year to 3 years, and also significantly reduced the parties involved in the DTT application process when submission is made through a sub-custodian who provides withholding tax agent services. MHBK is an approved withholding tax agent. Submission of DTT application forms can be done in electronic form. For example, certificate of residency can be submitted in scanned copy via PDF, and original forms are no longer required.

2. Eligible entities

The assets of individuals, corporations, and public entities may be eligible for reduced tax rates. Japan has entered into 90 DTTs with 157 countries or regions as of 1 March 2026, including all Group of Eight nations and the BRICs. The terms and conditions of these treaties differ depending upon the country, the entity, and the type of income (dividend or interest). Countries including Australia, France, the Netherlands, Qatar, Saudi Arabia, Sri Lanka, Switzerland, the United Kingdom, the United States, and Zambia, full tax exemption is possible in certain cases.

3. Article of limitation on benefits

The tax breaks on the dividend or interest on some DTTs include an article of limitation on benefits, which require certain investors (e.g., US residents, UK pension funds) to submit such documents as a certificate of residency (COR), a power of attorney, or a Form 17 (Attachment Form for Limitation on Benefit Article) with the DTT application form. Please see the table below for the documentary requirements for specific residents of major economies.

Chart VII-B-3: Necessary documentation to apply for DTTs with certain countries

A/C type	Dividend income	Interest income
Omnibus A/C	<p>Type of investors: US/UK/Swiss/Dutch pension funds, US residents</p> <p>Documents required: -Form 1-2 (*) -Form 17 (***) -Certificate of Residency (COR/IRS6166) for US investors</p> <p>Timing of submission: Every time income is entitled.</p> <p>Notes: The COR must be renewed every year (or every three years for pensions and certain US entities).</p>	<p>Type of investors: Financial institutions domiciled in US/UK/France/Australia/Swiss/Netherlands; UK/US/Swiss/Dutch/ French /Qatar pension funds, US residents</p> <p>Documents required: -Form 2 (**) -Form 17 (***) -POA -Certificate of Residency (COR/IRS6166) for US investors</p> <p>Timing of submission: Every time income is entitled</p> <p>Notes: The COR must be renewed every year (or every three years for pensions and certain US entities).</p>
Segregated A/C	<p>Type of investors: US/UK/Swiss/Dutch pension funds, US residents</p> <p>Documents required: -Form 1-2 (*) -Form 17 (***) -Certificate of Residency (COR/IRS6166) for US investors</p> <p>Timing of submission: Every time when entitled to dividend income</p> <p>Notes: The COR and Form 17 must be submitted at the time of account opening. The COR must be renewed every year (or every three years for pensions and certain US entities).</p>	<p>Type of investors: Financial institutions domiciled in US/UK/France/Australia/Swiss/Netherlands; UK/US/Swiss/Dutch /French /Qatar pension funds, US residents</p> <p>Documents required: -Form 2 (**) -Form 17 (***) -POA -Certificate of Residency (COR/IRS6166) for US investors</p> <p>Timing of submission: Every time when entitled to interest income</p> <p>Notes: The COR and Form 17 must be submitted at the time of account opening. The COR must be renewed every year (or every three years for pensions and certain US entities).</p>

(*) Special Application Form for Income Tax Convention (Dividend)

(**) Application Form for Income Tax Convention (Interest)

(***) Attachment form for limitation on benefits article

Note: For investors domiciled in countries that have DTT with Japan and are not mentioned in the above table, it is necessary to submit Form1-2 or Form 2 to apply for a preferential rate. However, in most cases, CoR is not required to submit.

C. Tax exemption for bonds held by non-residents

1. Structure of tax exemption

The government maintains a tax exemption structure for income on bonds held by non-residents known as the Japanese Bond Income Tax Exemption Scheme (J-BIEM). Originally, J-BIEM only applied to JGBs, and municipal bonds were added later. In 2010, corporate bonds were also included on a temporary basis, but the inclusion of corporate bonds to J-BIEM made permanent in 2013. Now, the types of bonds whose coupon income is covered under the new scheme when held by non-residents, subject to certain procedural requirements, include the following:

- Japanese government bonds
- Municipal bonds
- Straight corporate bonds
- Fiscal Investment and Loan Program (FILP) bonds (bonds issued by quasi-government entities not guaranteed by government, but mainly purchased with postal savings and pension funds; also called zaito bonds)
- J-REIT bonds
- TMK bonds (bonds issued by tokutei mokuteki kaisha, usually translated as “special-purpose company;” they are used for asset securitization, but cannot manage assets themselves)
- Convertible bonds (CBs)
- Commercial paper (CP)
- J-Sukuk (Islamic bonds)

Conversely, bonds not tax-exempt under J-BIEM include bonds not held at either of Japan’s two CSDs (JASDEC and BOJ) and certain profit-linked bonds issued by quasi-governmental institutions. Since 1 January 2016, redemption income derived from discount bonds are subject to withholding tax at maturity. The withholding tax on this redemption income is now also covered under J-BIEM. For this tax purpose, “discount bonds” include the following:

- Zero-coupon bonds issued at a discount and redeemed at par;
- STRIPS (Separate Trading of Registered Interest and Principal of Securities); and
- Non zero-coupon bonds issued at a deep-discount (i.e., 90% or less of the face value) and redeemed at par.

Japanese Bankers Association (JBA) issued a circular to its members on 14 November 2016, notifying the member banks that the National Tax Agency of Japan (NTA), and clarified the redemption income derived from T-Bills is not subject to withholding tax at maturity if T-Bills are issued at par or over par. This clarification is made to reflect the situation where T-Bills are issued at par or over par under the negative interest policy. With this notice, local agent banks ceases to withhold tax on redemption income for T-Bills originally issued at par or over par at maturity even held by a taxable investor (or held in “taxable account”) with no available tax remedy under J-BIEM or DTT. For avoidance of doubt, redemption income derived from T-Bills issued under par is still subject to withholding tax at maturity if held by a taxable investor with no remedy for tax exemption although only limited number of investors and T-Bills are affected.

2. Eligible entities

Now, individuals, corporations, qualified securities investment trusts, and foreign pensions and partnerships are eligible for J-BIEM. Application forms are available for all entities on the website of the Ministry of Finance. (<https://www.mof.go.jp/english/policy/jgbs/topics/taxation2016/5-2.html>).

3. Application procedures

As JGBs are tracked in the BOJ’s book-entry system and virtually all other bonds are handled in JASDEC’s book-entry system, the procedures for securing tax exemption for these two groups are slightly different.

Documentation/procedures necessary to obtain tax exemption

Coupon income on JGBs, municipal bonds, corporate bonds, and other bonds eligible for tax exemption under the J-BIEM tax scheme and that are held by non-resident investors is granted tax exemption so long as investors complete the necessary documentation. It is necessary for final investors to submit the following documents to a

local custodian bank before they purchase the bonds.

- Certificate of Residency
- Application form for Withholding Tax Exemption

For many years, QFIs were required to submit paper application forms with a signature. As the process has gradually become digitized, electronic submission in PDF format without a signature was introduced. Moreover, since April 2025, submission of the application form in Excel format (e-Tax format) has also been permitted.

For foreign financial institutions to hold bonds on behalf of third parties with tax exemption under J-BIEM, they need to obtain the four regulatory statuses for that purpose. Details of the statuses are as follows:

Required status to hold securities as clients' assets under Japanese laws

Any foreign financial institutions that intend to hold securities on behalf of a third party firstly need to apply for Foreign Account Management Institution (FAMI) from Financial Services Agency/Ministry of Finance/Ministry of Justice. Having received designation of FAMI, the applicant may then apply for the rest of the statuses described below.

Securing tax exemption on income from JGBs

When holding JGBs on behalf of a third party with tax exemption on coupon income, the tax code and the Bank of Japan require overseas custodian banks to obtain the status of Qualified Foreign Intermediary (QFI) and Foreign Indirect Participant (FIP). Beneficial owners must submit the documents necessary for obtaining tax exemption through a QFI. The QFI must verify the application form and forward the documents to its local custodian bank.

Securing tax exemption on income from municipal bonds

In the case of municipal bonds, overseas custodian banks must be a QFI and a Foreign Indirect Account Management Institution (FIAMI) as required by JASDEC to hold municipal bonds for a third-party eligible for tax exemption on the coupon. Beneficial owners must submit the documents necessary for obtaining tax exemption through a QFI. The QFI must verify the application form and forward the documents to its local custodian bank.

Securing tax exemption on income from corporate bonds, etc.

As with municipal bonds, overseas custodian banks are required to obtain QFI and FIAMI status when holding corporate bonds, etc. on behalf of a third party eligible for tax exemption on coupon income. Beneficial owners must submit the documents necessary for obtaining tax exemption through a QFI. The QFI must verify the application form and forward the documents to its local custodian bank.

Online guide to apply for Foreign Account Management Institution

In June 2017, JFSA posted the materials to support the application process of Foreign Account Management Institution over its website for the convenience of non-residents. This is a joint move made by JFSA, the MOF, and the Ministry of Justice (MOJ) as a part of the Plan for Regulatory Reform (Reform Plan) approved by the Abe Cabinet in June.

JFSA, MOF, and MOJ did not change the basic procedures, but rather enriched the explanatory materials available in English, and made them accessible via website. The gist of application process is summarized in "Application / Notification method", and template of forms for initial application, notice of change, rescission are also posted.

For avoidance of doubt, those summary procedures and forms do not affect the documents already filed as well as the pending application, and re-filing is not required, according to a JFSA official. "Q&A on Application / Notification" is published, and clarifies various frequently asked questions on wordings and requirements under the relevant rules, such as "representative," "evidential document as to the license in foreign country," "Designated Domestic Superior Institutions," "translation," and "term of validity of supporting documents".

https://www.fsa.go.jp/en/laws_regulations/fami/index.html

4. How tax status of bonds affects trading

"Clean" vs. "dirty" bonds – Repealed on 1 January 2016

One possibly unique feature of the Japanese financial system had been that both JGBs and other bonds are

separated into two categories at Japan's CSDs (BOJ and JASDEC): (1) "dirty bonds," whose coupon income is subject to withholding tax and (2) "clean bonds" whose coupon income is not. Since 1 January 2016, this rather peculiar dirty/clean framework has been repealed, and the taxability of the coupon arising from fixed-income financial instruments handled by the BOJ and JASDEC is simply determined based on the tax status of the holders as of each payment date. Consequently, if a bond is held by a taxable entity as of a coupon payment date, then the coupon is taxed for the whole coupon period; while a bond is held by a non-taxable entity as of a coupon payment date, then the coupon is tax-exempt for the whole coupon period.

a. Clean bond holders

Entities that belong to either of the following categories qualify as clean bond holders:

- Japan-domiciled designated financial institutions (e.g., Japanese banks, securities companies, insurance companies, and corporations with JPY100 million or more in capital [tax on dividend and interest income paid as part of corporate income tax at year end])
- Tax-exempt organizations (e.g., Japanese pension funds, sovereign entities, and non-residents that have completed the required documentation)

b. How non-residents qualify as clean bond holders

It should be noted that tax exemption is not granted simply because an investor is not a resident of Japan. As discussed in the preceding section in order to qualify for tax exemption under the J-BIEM tax scheme, non-resident investors have to hold bonds that are eligible for tax exemption through a financial institution that has obtained qualified status from the local tax office and the BOJ or JASDEC. They must also submit an "Application Form for Withholding Tax Exemption based on the Special Taxation Measures Law" and a certificate of residency to show that they are not a resident in Japan to their current custodian. If these documentation processes are not completed by the time a bond is traded, the bond will be subject to withholding tax and will therefore be deemed a dirty bond even if the holder is not a resident of Japan.

Samurai bonds

a. How withholding tax is imposed on coupon income from samurai bonds – basic principle

Prior to 1 January 2016, when a non-resident investor purchases samurai bonds, the bonds were required to be placed in a taxable account at JASDEC. Once it was placed in the taxable account at JASDEC, the position was deemed dirty in the market. However, from January 2016 onwards, the clean/dirty distinction for samurai bonds at JASDEC level is lifted, and the account at JASDEC for samurai bonds is unified into one as other types of corporate bonds.

b. Exception

Although Samurai bonds are not subject to tax exemption defined under J-BIEM, no withholding tax is actually imposed on coupon income because Japan cannot levy a tax on the interest income paid on a samurai bond to a non-resident investor. Simply put, the Japanese tax authorities cannot collect taxes when both the issuer and the investor are domiciled outside Japan.

D. Tax reclaim

1. Overview

For investors who are non-residents of Japan, it is possible to enjoy a preferential tax rate to dividend/interest income in Japan, if so defined in the double tax treaty which Japan has established with the country where the investors are based for tax purposes. Applicable tax rate is usually adjusted at source by submitting the documents and information required under the relevant rules and regulations prior to deadline.

If an investor fails to submit the documents by deadline, its dividend income will be taxed at the statutory rate regardless of its tax domicile and availability of the preferential rate defined in the applicable tax treaty. Tax reclaim is available in Japan for such investors who are overtaxed for their failure to meet the deadline. For tax reclaim procedures, certificate of residency or other information such as payment data can be submitted in electronic form, and submission of original documents is no longer required.

2. Steps to be taken

Step 1: Global custodians collect information on securities and the beneficial owners.

A beneficial owner as an applicant needs to provide the following information for each security it is applying for tax refund to the local custodian in Japan.

- Record date
- Payment date of the issue (if available)
- Name of the issue
- ISIN code
- Quantity of the shares or the face value of the debt instrument held as of the record date
- Amount to be reclaimed
- Beneficiary's name, address and tax ID
- Custody account number at Mizuho Bank
- The name of the law that defines the applicant's tax exemption status (in the case that tax exemption applies)

Step 2: Local custodian in Japan fills in the application form on behalf of the investor

In this process, the following points are checked at the local custodian.

- Accuracy of the amount actually taxed
- Record date
- Accuracy of the dividend/interest rate
- Quantity of the shares/face value of the debt instrument
- Amount to be refunded
- Non-existence of the duplicated reclaim filed in the past

Step 3: Local custodian in Japan submits application form and other documents to the local tax office

The following documents should also be delivered to the local custodian in Japan.

- Instruction from the client to initiate the tax reclaim
- Certificate of Residency (must be issued within one year and bears Tax Years covering the dividends/coupon payment dates)
- Power of attorney (PoA) issued by the applicant (i.e. beneficial owner)
(If the reclaim is initiated via a global custodian bank, the PoA delegating the reclaim to the global custodian should be delivered to the local custodian.)
- A photocopy of the PoA is acceptable, if it is duly notarized.
- An evidential document of the amount taxed
- Form 17/Attachment Form for Limitation on Benefits Article
(if the applicant is a US resident or a pension fund based in US/UK/Netherlands/Switzerland)
- Declaration letter (if the applicant is a US Group Trust or a pension fund based in US/UK/Netherlands/Switzerland)

3. Standard timeframe

From data collection to reconciliation: It usually takes approximately 2 weeks to complete the data reconciliation at the local custodian after its receipt of the data.

Creation of the application form and preparation of other documents: This process also takes approximately 2 weeks from the completion of the data reconciliation.

From filing of the documents to refund: It takes by and large from 3 to 12 months after filing.

Refunds credit: Refunded money will be credited to the client's cash account soon after the local custodian receives the refund from the local tax office in the jurisdiction and completes checking. In case of Mizuho Bank, credit advice will be issued as confirmation.

4. Statute of Limitation

Tax reclaim applications (under an appropriate tax treaty) for over-withheld tax on interests or dividends must be filed with the Japanese withholding agent within five years after the date of interest/dividend payment (i.e. the tax was withheld).

VIII. Regulatory Authorities

A. Overview

1. Financial Services Agency (FSA)

The Financial Services Agency (FSA) is an arm of the Cabinet Office and is independent from the Ministry of Finance. It is responsible for ensuring the stability of the financial system through planning and policymaking, as well as protecting the interests of securities investors, insurance policyholders, and depositors. In this regard it has three major duties: (1) inspection and supervision of private-sector financial institutions, (2) planning for domestic financial infrastructure, and (3) planning for infrastructure related to private-sector financial institutions' international operations. The FSA is also responsible for the disposition of failed financial institutions and the surveillance of securities transactions.

In August 2017, JFSA unveiled its plan to dissolve the Inspection Bureau through its budget application for the next business year commencing in July 2018. JFSA is to shift the objective of its inspection and supervision from mere checking of minimum requirement fulfillment to active supervision that enables financial institutions to achieve sustainable soundness through dialogue with financial institutions to pursue best practice. In the past, JFSA has been conducting rigid inspection in accordance with the financial institution inspection manual, focusing on ex-post fact checking of compliance and asset valuation. Reduction of non-performing loan and customer protection were the priority, and the inspection by JFSA helped banks to regain soundness and market stability. The strategy was very effective, and NPL ratio of major banks goes down below 1%. Inspection Bureau will be mainly consolidated into Supervisory Bureau, which monitors the activities of financial institutions through their periodic reports to JFSA.

2. Securities and Exchange Surveillance Commission (SESC)

The SESC is a part of the FSA and works to ensure the fairness of transactions in securities markets. Its main responsibilities are market surveillance (documentation of securities trading), oversight of securities companies (inspections, compliance rules related to customer records, etc.), trading inquiries (price manipulation, etc.), disclosure oversight, and investigations for possible criminal and civil violations.

3. Bank of Japan (BOJ)

The BOJ serves as Japan's central bank and the central depository for JGBs. As the central bank, the BOJ supervises the operations of domestic financial institutions. The BOJ is also responsible for continuously reviewing and improving the efficiency of the procedures and systems for cash and JGB clearing.

4. Self-regulatory organizations (SROs)

In addition to the external regulation provided by the authorities mentioned above, the following entities serve as the main self-regulatory organizations (SROs) in the market:

Japan's securities exchanges (TSE, NSE, FSE, SSE)

Japan's stock exchange operators establish rules for their participants to maintain fairness and credibility in the market, monitor adherence to the rules, and take disciplinary action when necessary.

Japan Securities Dealers Association (JSDA)

The JSDA is the industry association that formulates rules for securities companies in order to ensure efficiency and fairness in securities trading. It conducts inspections of member companies and takes disciplinary action when necessary.

Investment Trusts Association, Japan (JITA)

JITA is a self-regulatory body that establishes and enforces rules in order to protect investors and contribute to the sound development of investment trusts and investment companies.

B. Regulatory structure

Please see the diagram below for a basic illustration of the regulatory structure of the market.

Chart VIII-B

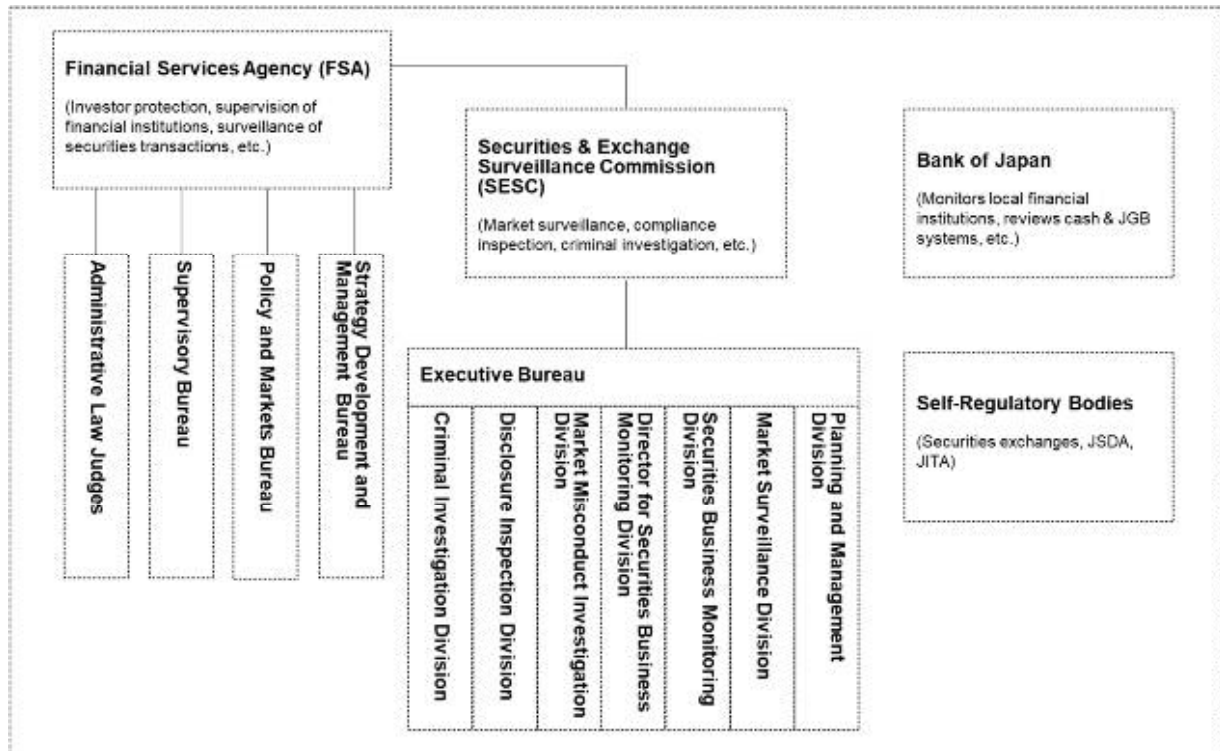

IX. Corporate Actions

A corporate action is any action by an issuing company that affects entitled shareholders or involves payments to and from shareholders. In Japan, investors in equities and bonds are entitled based on the settled position as of the record date, not on the trade date as is the case in Western markets. For shareholders to be entitled and to participate in corporate actions, it is necessary for trades to be duly settled and for names to be registered at the issuer by the record date. In the case of bonds, the record date is one day prior to the coupon payment date. Coupon payment dates are usually twice a year.

A. Types of Corporate Actions in Japan

1. Mandatory events

Merger

Mergers have become more common in Japan in recent years. Generally mergers are conducted as statutory mergers whereby only one of the entities survives and takes over the assets, rights, and obligations of the dissolved entity. In return, former shareholders of the dissolved entity are compensated with shares of the surviving company. Otherwise, companies merge to form an entirely new company. This has the drawback, however, that the new company must reapply to list on a stock exchange in addition to other requirements that make this a less attractive option. Mergers can be conducted through stock swaps, stock transfers (stocks transferred to a new parent company usually to create holding company), and stock acquisitions.

Change of board lot size

As discussed in I-A-2, each stock has a designated number of shares that is its board lot (or trading unit), and all exchange trading is conducted in multiples of this number of shares. Companies often reduce their board lot size if their share price becomes high enough to discourage investment or reduce liquidity. Since 1 October 2018, the trading unit used by all the Japanese listed companies has been unified to 100 shares.

Change of company name

Approval at a company's shareholders meeting is required for a name change.

Stock split

This refers to the situation when a company splits its existing shares, thus increasing the number of shares outstanding. Stock splits are quite common in the Japanese market. Companies usually conduct stock splits when the share price has become high enough to hamper the liquidity of the stock.

Bonus issue

Bonus issues are usually carried out through the free distribution of new shares for the purpose of returning profits to shareholders. When a bonus share is entitled, the additional balance is automatically reflected in the investor's JASDEC balance on the effective date. If the company only issues common shares, then bonus issues are virtually indistinguishable from stock splits. Bonus issues are uncommon in Japan.

Pari passu

This refers to the assignment of equal rights for payment of obligations or securities. Pari passu is very rare in the Japanese market. After a recent revision in the law, it currently only occurs with rights issues.

Bankruptcy

When bankruptcy occurs, shareholders can only claim assets once creditors are repaid, so in most cases, stocks become virtually worthless. Under Japanese law, foreign creditors are treated exactly the same as domestic creditors.

Delisting

Delisting occurs when a company whose stock is listed at a given exchange does not comply with the listing requirements of the exchange, or when the company withdraws voluntarily from the exchange, such as after a merger or management buyout.

Liquidation

Liquidation refers to selling off a company's assets to pay off creditors. In theory, shareholders get whatever is left over after the creditors are paid off, and preferred shareholders take precedence over common shareholders. However, in most cases, shareholders do not receive any compensation.

2. Voluntary events**Tender offer**

A tender offer can be triggered either when a party acquires a stake of (1) more than 5% of a company's shares from eleven or more investors in off-market transactions, or (2) more than one-third of a company's shares from ten or fewer investors, designated transactions, and on- and off-exchange transactions. Entities initiating a tender offer must purchase all shares offered by shareholders if the entity is seeking to obtain more than two-thirds of a stake in the target company (See IX-B for more information). This protects investors since the tender offer could result in the company that is the target of the tender offer being delisted, which could make it difficult for shareholders to sell their shares otherwise.

Subscription of warrant

As mentioned I-C-5, a warrant grants the holder the right to purchase a security (usually a stock) by issuer at a specified price and within a specified timeframe. Warrants are generally issued either as a reward to shareholders or to defend against hostile takeovers. In Japan, the latter is more common.

Allotment of subscription warrants to shareholders (rights issue) – Rights Offering

Allotment of subscription warrants to shareholders, i.e., rights issue, provides companies with a third method of equity fundraising aside from public offerings and private placement by allowing firms to grant their shareholders the right to buy new shares below market price. The scheme allows issuers to list their equity warrants on the TSE (other markets do not handle) provided the rights issue meets the listing standard, and the warrants are traded and regulated as normal securities for a certain period of time. When listed, the shareholders who received allotment of subscription warrant can either receive new shares by exercising the rights at the specified strike price, or alternatively, sell the rights over TSE at market price. Third party investors have opportunities to acquire the rights on exchange, then they can also either receive new shares by exercising the rights at strike price, or sell the rights again on exchange. In addition, the scheme allows warrants to be issued in a fractional ratio of the underlying equity. For example, it is possible for one stock to correspond to 0.7 units of a warrant or 1.7 units of a warrant under the scheme. Since US securities laws require reporting to the Securities and Exchange Commission from companies in which US investors own a stake of 10% or more even if the issuer is incorporated overseas, the Financial Services Agency allows companies to restrict the exercise of subscription warrants to avoid the undue burden that English-language reporting would entail.

Conversion

Conversion refers to the exchange of one asset for another, such as convertible bonds. The date and price of the conversion are usually decided in advance.

Sale of odd lot shares

Odd lot shares refer to a quantity of stock smaller than the standard trading unit. Odd lot shares are usually generated from corporate action entitlements such as stock splits, rights issues, or the exercise of conversion of warrant rights. These trades may be settled at JASDEC via transfer agent with the issuer but not on exchanges.

Proxy voting

Given most companies set March as their fiscal year end, shareholders meetings in Japan are concentrated in the final week of June, making the proxy voting process extremely labor-intensive (see IX-D for more information).

3. Corporate actions affecting bonds

There are three types of actions associated with bonds in the Japanese market. First, there can be a call option on a bond when it is issued, allowing the issuer to retire the bond before maturity. Second, issuers can attach a put option to bonds, giving holders themselves the option to redeem the bond before maturity. However, both are rare in the

Japanese market. In the case of convertible bonds, holders have the option to convert them into stocks.

B. Tender offer regulations

1. Definition of tender offer

Basic criteria

A tender offer takes place when an offeror intends to increase its ownership ratio of a target company to a certain level. The following table illustrates the principal criteria to judge whether acquisition of shares should be regarded as a tender offer.

Chart IX-B-1

Cases regarded as a tender offer		
Ownership after tender offer	Number of shareholders to whom tender offer is made	
	11 or more unspecified shareholders within 60 days	10 or fewer unspecified shareholders within 60 days
5% or less	Not required	Not required
More than 5 % - one third	Required	Not required
More than one third	Required	Required

Other transactions to be regarded as tender offers

In addition to the above, the following types of transactions are regarded as tender offers:

- a. Where a combination of on-exchange and off-exchange transactions carried out over a short period of time (less than three months) results in the purchase of more than 10% of outstanding securities, the portion of the purchase made either on-exchange or off-exchange exceeds 5% of outstanding securities, and the ownership ratio following these transactions exceeds one third of outstanding securities.
- b. Where an entity that owns over one-third of outstanding securities purchases more than 5% of outstanding securities during a period in which another entity is carrying out a tender offer. This is sometimes referred to as a “counter tender offer.”

Amendments effective on and after May 1, 2026

On May 1, 2026, the amended Financial Instruments and Exchange Act will come into effect, and the rules of tender offer will be revised. The following table shows the new criteria.

Chart IX-B-2

Cases regarded as a tender offer		
Ownership after tender offer	Number of shareholders to whom tender offer is made	
	11 or more unspecified shareholders within 60 days	10 or fewer unspecified shareholders within 60 days
5% or less	Not required	Not required
More than 5 % - 30%	Required	Not required
More than 30%	Required	Required

Under this amendment, the representative threshold for tender offers—namely, the shareholding ratio of one-third—has been lowered to 30%. This change reflects the fact that many foreign jurisdictions set the threshold at 30%, and that, given voting patterns at shareholders meetings of Japanese listed companies, holding 30% of voting rights generally allows a shareholder to block special resolutions and exert significant influence over ordinary resolutions.

Additionally, from the perspective of ensuring transparency and fairness, on-exchange transactions (auction market

transactions), which were previously excluded under the existing system, have been brought within the scope of the rules.

On the other hand, a new exemption system for minor acquisitions has been introduced. If a person who already holds more than 30% of shares makes a purchase that results in an increase of less than 0.5% and, after the increase, their total holding does not reach two-thirds or more—among other specified requirements—a TOB is not required. This exemption was introduced in recognition of the fact that, when the number of shares subject to acquisition is minor, the impact on corporate control is generally minimal.

Note: In conjunction with this amendment, as part of the simplification and rationalization of regulations, the rules previously in place for a. (rapid acquisition transactions) and b. (acquisitions during another party's tender offer period) will be abolished.

2. Tender offer rules

General rules

Conditions for purchasing shares must be equal for all shareholders, and, once announced, offerors may elect to raise the offering price but not lower it. Also, an offeror is not permitted to purchase any shares of the target company by any other method during the tender period and may not cancel the tender offer, except that the target company files for bankruptcy or merges with another company. Moreover, if response from shareholders exceeds the solicited amount of the offeror, shares are to be purchased proportionally, but the offeror must purchase all shares offered by shareholders if the offeror is seeking to acquire a stake of two-thirds or more in the target company. This regulation is to protect investors in the event that the tender offer results in delisting of the target company.

Tender offer period

The period for a tender offer must be between 20 and 60 business days. The period is calculated by the number of business days rather than calendar days in order to provide shareholders and investors with enough time to consider whether to accept the offer.

Parties involved to a tender offer are also subject to the following rules of conduct during the tender offer period to ensure a fair transaction.

Disclosure rules for the offeror

The offeror is required to give public notice regarding the tender offer. It must also report the offer to the government. Additionally, the offeror has to send notification of the event to the target company and an explanatory brochure on the offer to shareholders of the target company.

Disclosure rules for the target company

The company that is the target of the tender offer is required to render its opinion about the offer within ten business days following the day the offer is made. This response is made in the form of a report that is submitted to the government, and its copy must be sent to the offeror. If this opinion report contains questions for the offeror, the offeror has to answer the questions in a counter-report, which must be submitted within five business days.

3. Issues for non-residents

Opening a brokerage account

Non-resident investors who wish to participate in a tender offer must open an account at the tender agent, usually a broker, in Japan. This requires a prospective participant to submit proper identification documents issued by the government of its country of residency to the local custodian. The local custodian then takes necessary procedures to open the brokerage account. The Japan Securities Dealers Association (JSDA) also requires the applicants to verify that they are not affiliated with any criminal organization with the broker at which they open an account to apply for a tender offer. Nearly all brokers follow this rule.

Availability of English materials

Although it is totally up to entities involved in each tender offer whether to make English versions of above-

mentioned disclosure documents available, detailed information is rarely made available in English, partly because of many legal restrictions on the residency of those who can tender shares.

Notification by local custodian

If a tender offer is conducted for an issue held by non-residents whose assets are kept by a local custodian in Japan, the local custodian generally delivers certain items of information to its clients, such as offer price, tender offer period, name of the offeror, and whether there are any restrictions concerning the residency of those who are entitled to subscribe the offer. In cases where such restrictions are announced, it is necessary for shareholders who wish to tender shares to inform the local custodian in writing that the restrictions do not apply to them. The local custodian then forwards the statement to the offeror.

There are also cases where a tender offer may result in delisting of the target issue (such as when a company conducts a tender offer to acquire a firm as a wholly owned subsidiary). In such a situation, the local custodian advises investors who would be affected by such event.

Limitations on participation by residency

It is often the case that an event has a restriction that investors domiciled in some countries are not allowed to participate. The most common case is a restriction for US based shareholders. This is because US tender offer rules are generally considered to cover transactions involving companies outside the US, if those companies have US residents in their shareholders. Since an offeror would have to take complicated procedures in accordance with additional rules to deliver information of the event to US residents and to pay additional costs if they get US based shareholders involved to the event, most of offerors shy away from doing so.

C. Calculation of FOL entitlements

Now that all listed shares have been dematerialized in the Japanese market, FOL limits are calculated by JASDEC, and entitlement is fixed through JASDEC's notification of all shareholders at every record date (every six months). JASDEC notifies the daily FOL ratio (only for "direct foreign ownership") in English on its website, at the following URL:

https://www.jasdec.com/en/description/less/for_pubinfo/for_pubinfo.html

Direct foreign ownership is defined as shares held and registered directly by an entity that is owned by non-Japanese entities and located outside of Japan. Indirect foreign ownership is defined as shares held and registered by a Japanese entity which is partly owned by non-Japanese entities and located outside of Japan. Although direct foreign ownership is updated daily at JASDEC, indirect foreign ownership ratio is calculated by registrars/issuers at every record date.

In the event that the FOL limit is reached, JASDEC carries out the relevant calculations in the following way:

1. Entitlement

Before the FOL ratio reaches the limit, the portion increased from the previous record date is duly registered into foreign names on the record date.

After the FOL ratio reaches the limit, entitlements to foreign holders are made on pro-rata method, based on the ratio of "number of shares available for additional registration up to the limit on the previous record date" and "increase in the number of shares held by foreign holders from the previous record date."

For example, for the following scenario, assume ABC Bank held 100 shares of NTT as of the previous record date and is holding 220 shares over the next record date.

- (1) NTT's FOL limit: 10,000 shares
- (2) Registered shares on the previous record date: 8,000 shares
- (3) Shares held by foreign holders on the record date: 13,000 shares

Under the circumstances, only 2,000 shares, (1) – (2), are open for registration although 5,000 shares, (3) – (2),

have been newly held by foreign entities since the last record date.

Chart IX-C-1

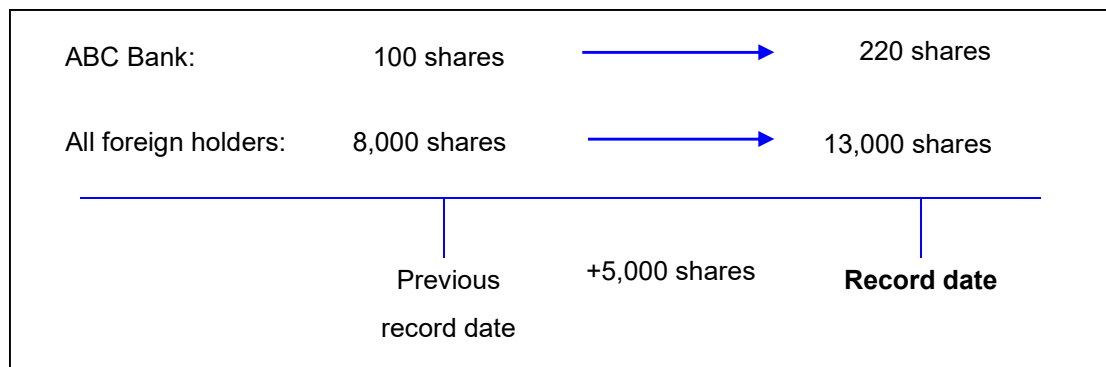

In this case, the number of shares to be open for registration by ABC Bank is determined on the following formula:

$$(220 \text{ shares} - 100 \text{ shares}) \times 2,000 \text{ shares} / 5,000 \text{ shares} = 48 \text{ shares}$$

2. Fractional shares

If the total amount of shares figured out on the above formula were 48.4 shares, whether the fractional portion of 0.4 shares would be rounded up or down would be subject to a lottery. In other words, a lottery will be used only in the case in which allocation on a pro-rata basis is not possible, and mainly to determine rounding up or down of fractional shares allocated.

In the event that the limit is reached or exceeded, investors can buy and hold shares, but registration of the shares will be rejected. In other words, foreign investors are not entitled to participate in any corporate actions for the positions for which registration is rejected, but they can trade and hold the positions.

D. Details of proxy voting

1. Overview

Like most developed nations, Japanese law requires companies to hold annual general meetings (AGMs) once a year, while extraordinary shareholders meetings (EGMs) are held as needed. Although not specifically required by law, Japanese firms generally stipulate in their articles of incorporation that AGMs will be held within three months after the fiscal year end due to the Companies Act mandating that voting rights to be exercised within this time frame. Since most Japanese companies' close their books in March, the deadline for these firms' AGMs falls at the end of June. To keep shareholders' sway on corporate governance in check—a move spurred by corporate racketeers called *sokaiya* a few decades ago—listed Japanese companies concentrate their AGMs on the second to last business day in June. This practice discourages investors with stock in multiple firms from attending the meetings of every company in which they hold shares. In the mid-1990s, over 90% of TSE-listed companies that close their books in March held their shareholders meetings on this day, but the percentage has receded to less than half that level in recent years as the major bourses have discouraged such tactics. That said, the large proportion of AGMs still held at the end of June makes the proxy voting process extremely labor-intensive.

2. Online Shareholder Meeting

Companies Act stipulates that the shareholders meeting must be held at an actual venue, however in the wake of the coronavirus outbreak in 2020, companies wanted the shareholders meetings to be held entirely online, but actually, only some took place in hybrid style, at a physical venue and online, as the Companies Act has been interpreted to require companies to set up a physical venue for shareholders meetings. Some were held as “virtual observation type” which can be viewed online, and some were held as “virtual attendance type” in which shareholders may vote and ask questions online. The Act on Strengthening Industrial Competitiveness which was revised and partly enforced on 16 June 2021 enabled to hold a full online shareholders meeting. In principle, it requires the issuers to amend their Articles of Incorporation after the completion of confirmation process with the Minister of Economy, Trade and Industry and the Minister of Justice to hold a full online shareholders meeting, however the amendment is not required for the first two years due to the global pandemic. On 26 August 2021, the first full online shareholders meeting was held in Japan.

Currently, the Legislative Council of the Ministry of Justice (an advisory body to the Minister of Justice) is considering relaxing the requirements for fully online shareholders' meetings.

3. Determining entitlement

Not all shareholders are entitled to voting rights. Listed Japanese companies organize their shares into trading units to 100 shares. Shareholders are entitled to one vote for each trading unit held and shareholdings of less than a single unit do not confer voting rights. Companies holding their own shares are also ineligible to vote, as are shareholders if one of the items on the ballot is to approve the resale of this shareholder's shares to the issuer. In addition, subsidiaries that hold shares in their parent are excluded from voting. A company is also prohibited from exercising voting rights if it owns shares in a company that has a stake of 25% or more in it. Finally, companies may opt to issue up to half of their outstanding shares in the form of stock that restricts or eliminates voting rights.

4. General operational flow for proxy voting

Entitlement fixed on record date

Investors are entitled to voting rights based on ownership registered by the transfer agent at the fiscal year end, which usually falls on the record date of the issue, not on the day of the AGM. So, in practice, an investor that liquidates his position after the fiscal year end can still vote three months later at the AGM. Due to this system, share blockings do not take place for proxy voting in Japan. Proxy voting is processed as indicated in the following chart.

Chart IX-D-3

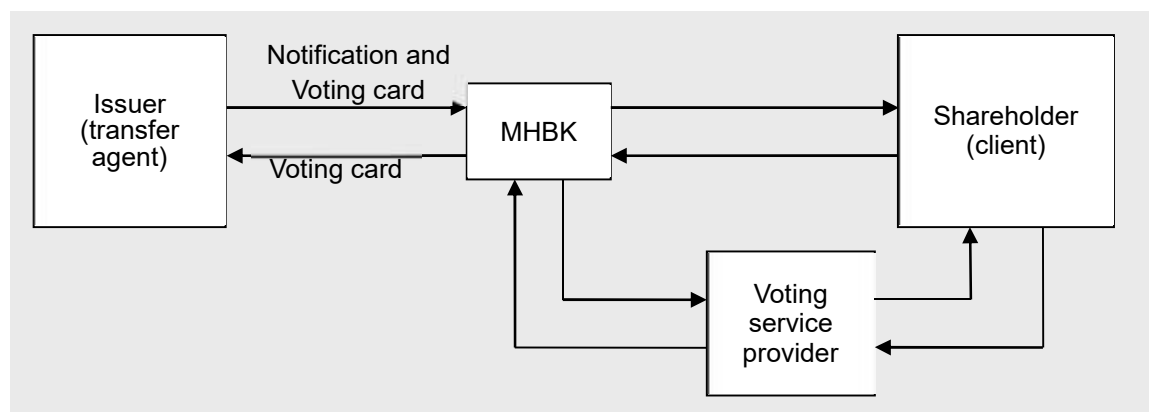

Notification of AGMs & EGMs

Japanese law stipulates that listed companies send shareholders notifications of the AGMs and voting cards at least two weeks before the meeting date. In practice, its transfer agent (usually a trust bank) sends notifications as defined in the law. The notifications are pamphlets usually around 30-50 pages and include a wide array of information including the composition of the board of directors, financial statements for the fiscal year under review, and an overview of operations, as well as the place, date, time, and agenda of the meeting. Voting cards are just single sheets of paper roughly the size of a postcard. They list the registration number of the shareholder, the number of voting rights, and two fields for the shareholder to check in favor of or against each proposal.

In the above chart, the issuer sends voting cards and the announcement of the AGM to local custodian banks. In reality, most listed companies opt to outsource this and other related services to trust banks. The trust bank is referred to as a transfer agent when acting in this capacity. Since Japanese companies seldom issue their voting cards and AGM announcements in any language other than Japanese, many companies ask that the materials be forwarded to a voting service provider, which translates the materials into English for the shareholder. One of the dominant voting service providers in Japan is Broadridge Financial Solutions, Inc. (Broadridge), and it also offers advice to shareholders on how to cast their ballots.

Electronic Distribution of Shareholders Meeting Materials

Part of the revised Companies Act promulgated in December 2019, which enables electronic distribution of shareholders meeting materials, was enforced on 1 September 2022. It is a system that enables electronic provision of reference materials for shareholders meeting, financial statements, business reports, etc., without obtaining individual shareholders' consent by incorporating it into the companies' articles of incorporation. Reference materials for the shareholders meeting, etc. needs to be posted to the website three weeks prior to the date of the shareholders meeting or the date sending the convocation notice, whichever comes earlier. Convocation notice stating the date and place of the shareholders meeting needs to be sent two weeks prior to the date of the shareholders meeting (URL needs to be listed in the convocation notice). Paper materials will be delivered to shareholders upon request only. Listed companies will be deemed to have resolved to amend the articles of incorporation on the enforcement date of the act (1 September 2022), so the amendment will be applied forcibly to listed companies.

How voting instructions can be sent

There are four ways that shareholders may cast their votes:

- (1) Direct submission at the AGM
- (2) Mailing the voting cards by post
- (3) Voting on an online system operated by the transfer agent at the issuer's discretion
- (4) Voting on the online system operated by Investor Communications Japan (ICJ)

Virtually all proxy voting is conducted either by post or through ICJ, and the latter is far and away the most common. ICJ, a company jointly owned by the Tokyo Stock Exchange and financial technology service provider Broadridge, operates a computer platform for the execution of proxy voting. On 9 April 2025, ICJ announced that 1,839 companies or 48.1% of the companies listed in the TSE, and 1,566 companies or 95.9% of the companies listed in

the Prime market of the TSE has introduced the ICJ's voting system. The system has proven popular since its inception in 2004, largely due to the voting rights of beneficial shareholders not being clearly spelled out in Japan's financial framework and proxy voting generally being conducted in the Japanese language only. If both the stock issuer and the shareholder subscribe to ICJ's platform, voting may be conducted digitally directly between the issuer (or transfer agent) and the shareholder without the local custodian's assistance. The number of participating companies to ICJ's voting platform drastically increased in 2016. The enforcement of the corporate governance code coupled with the recommendations made by the working group set up by METI motivated listed companies to go on board, as an effective measure to give additional one or two weeks to investors for making voting decisions, especially to cross-border investors.

On the other hand, if either the stock issuer or the shareholder is not a member of ICJ, then the process must be conducted using physical voting cards. Accordingly, even stock issuers that are ICJ members must still prepare physical voting cards since at least some of their shareholders will inevitably not subscribe to the system.

Processing of voting instructions at local custodian

Local custodian banks use only voting cards and do not use any online voting systems operated by the stock issuer (or transfer agent). Shareholders' votes must arrive at the local custodian's doorstep by no later than three business days before the AGM or EGM to take into account the time it will take for the cards to travel through the postal system to the issuer (or transfer agent). The market deadline for the return of the voting card to the issuer (or transfer agent) is one business day prior to the AGM and EGM.

Five pieces of information must be recorded on the voting card for it to be counted as valid:

- (1) The issuer's name
- (2) The shareholder's (nominee's) account number
- (3) The number of voting rights
- (4) The number of the proposal to be decided by the vote
- (5) How the shareholder will vote

One voting card is issued per account. Segregated accounts service a single client, so voting cards can be filled out as is. Omnibus accounts, however, represent multiple underlying investors in a single account who may want to vote differently from one another. The account holder tallies the number of votes (remember one trading lot = one vote) into each of three categories: for, against, and abstain. The votes of each final beneficiary in the omnibus account is recorded on a separate page and attached to the voting card. All listed Japanese companies accommodate split voting to allow underlying investors to vote in omnibus accounts.

It should also be noted that the above-mentioned "one voting card per one account" rule makes it impractical for underlying investors in an omnibus account to physically attend the meeting. In Japan, a voting slip also acts as an admission card for the meeting. As the name of the omnibus account is indicated on the slip, it is virtually impossible for underlying investors to prove to the issuer that they are the real beneficial owner of the shares. However, the implementation of "Stewardship Code" and "Corporate Governance Code" is gradually changing these practices. One of the underlying concepts of these "Codes" is to foster the investee companies' corporate value and sustainable growth through constructive engagement or purposeful dialogue. In line with the implementation of these codes, the relevant ministries, stock exchanges, issuers and financial service providers have been discussing to find ways to be more flexible about accepting attendance of underlying investors to the shareholders' meeting if the shareholder on record agrees to issue a power of attorney. Although it is yet to be certain about whether this procedure will become a universal practice in the market, the situation is likely to change to investors' favor.

The announcement of the result of the vote is made in the form of extraordinary report (only available in Japanese) to be disclosed over EDINET after the AGM. The issuer may or may not put the results on its Website and may or may not issue them in English.

E. General flow of shareholder proposal on AGM agenda

1. Overview

Each company has its own procedures for submission of shareholder proposal to AGM, and it is strongly recommended to confirm with each issuer as the first step. Having said the above, for reference purpose only, the most general procedures are as follows.

2. Statutory requirements for AGM agenda proposal

Under the Companies Act of Japan, a shareholder shall have to hold:

- (1) 1% or more of total voting rights; or
- (2) 300 or more voting rights;

for the period of at least 6 months to make a proposal for AGM agenda.

3. Proving the fulfilment of statutory requirements

To demonstrate a shareholder satisfies the above mentioned statutory holding threshold tests, under the Act on Book Entry of Corporate Bonds and Shares, the shareholder shall take the following steps:

- (1) Request the account management institution with which the shareholder holds securities account to make an “individual shareholder’s notice” to communicate the information of shareholding by such shareholder to the issuer through JASDEC.
- (2) To complete this “individual shareholder’s notice” to the issuer, JASDEC generally takes at least four business days (but may sometimes take around 10 business days, according to the material published by JASDEC) from the date it received the request from the account management institution.
- (3) Upon completion of such notice from JASDEC to the issuer, a confirmation will be provided to the shareholder through the account management institution
- (4) The shareholder shall attach either such confirmation or other documents (depending on the issuer’s procedure) as to the completion of individual shareholder’s notice to its AGM agenda proposal.
- (5) The shareholder shall make an AGM agenda proposal to the issuer within four weeks of the date of such an individual shareholder’s notice and eight weeks ahead of AGM (might be shortened by the article of incorporation of each issuer).

4. Required account structure

It shall be noted, in order to make above mentioned individual shareholder’s notice, a non-resident investor shall hold an account in the name of the shareholder who is making a proposal with a foreign indirect account management institution (FIAMI) when a shareholder is holding shares through layers of account management institution involving global custodian and local custodian.

Further, to demonstrate the satisfaction of the holding requirements under the Company’s Act, the shareholder shall hold assets in such a segregated account for the period required under the Company’s Act.

Therefore, it is strongly recommended to plan and move well ahead of AGM season if any shareholder intends to make an agenda proposal in AGM.

F. General flow of calling a Shareholders’ Meeting

1. Overview

In order that a shareholder would call a shareholders’ meeting, the shareholder shall take necessary steps in accordance with the relevant rules in Japan, including the Companies Act and the Act on Book-Entry Transfer of Company Bonds, Shares, etc. as well as the Articles of Incorporation of the issuer. Further, there is a requirement for using “Contents-Certified Mail Service (naiyou shoumei yuubin) by Japan Post, a specific communication measures provided only domestically in Japan. Therefore, it is strongly recommended to seek professional advice from legal experts in Japan, and make necessary confirmation with each issuer as the first step. Having said the above, for

reference purpose only, the most general procedures are as follows:

- (1) Satisfy the holding requirement
- (2) Make a formal request to a representative director of the issuer in accordance with the statutory formality
- (3) File a motion to competent court to grant a permission to call a shareholders' meeting; only when the issuer would not commence necessary procedures to call a shareholders' meeting in a timely manner after receipt of the formal request from the shareholder in item (2) above then the issuer
- (4) Hearing by the competent court
- (5) Ruling by the competent court
- (6) Call a shareholders meeting pursuant to the statutory procedures if the competent court grants a permission to call a shareholders' meeting
- (7) Hold a shareholders' meeting

2. Statutory requirements for calling a shareholders' meeting

Under the Companies Act of Japan, a shareholder shall have to hold:

- (1) 3% or more of total voting rights;
- (2) for the period of at least 6 months to call a shareholders' meeting.

3. Proving the fulfilment of statutory requirements

To demonstrate a shareholder satisfies the above mentioned statutory holding threshold tests, under the Act on Book Entry of Corporate Bonds and Shares, the shareholder shall take the following steps:

- (1) Request the account management institution with which the shareholder holds securities account to make an "individual shareholder's notice" to communicate the information of shareholding by such shareholder to the issuer through JASDEC.
- (2) To complete this "individual shareholder's notice" to the issuer, JASDEC generally takes at least four business days (but may sometimes take around 10 business days, according to the material published by JASDEC) from the date it received the request from the account management institution.
- (3) Upon completion of such notice from JASDEC to the issuer, a confirmation will be provided to the shareholder through the account management institution
- (4) The shareholder shall submit either such confirmation or other documents (depending on the issuer's procedure) as to the completion of individual shareholder's notice with its request to a representative director of the issuer for calling a shareholders' meeting.
- (5) The shareholder shall file a motion to seek the approval from the competent court after making a formal request to a representative director to which the issuer failed to commence procedures to call a shareholders' meeting.

4. Required account structure

It shall be noted, in order to make above mentioned individual shareholder's notice, a non-resident investor shall hold an account in the name of the shareholder who is making a proposal with a foreign indirect account management institution (FIAMI) when a shareholder is holding shares through layers of account management institutions involving global custodian and local custodian.

Further, to demonstrate the satisfaction of the holding requirements under the Company's Act, the shareholder shall

hold assets in such a segregated account for the period required under the Company's Act.

Therefore, it is strongly recommended to plan and move well ahead of actually considering calling a shareholders meeting.

G. Attendance of non-resident investors to AGM

1. Overview

The National Kabukon in Japan ("Kabukon": Zenkoku Kabukon Rengōkai) released an English version of "Guideline on Attendance at the General Shareholders Meetings of Japanese Listed Companies by Global Institutional Investors" (Guideline) in December 2015. Under the Guideline, "Global Institutional Investors" are defined as institutional investors who are not on the shareholders registry of listed companies. Paving a way for attendance of institutional investors that are not on the registry to AGM, in order to facilitate constructive dialogue between investors and listed companies, is also a supplementary principle (1.2.5) under the Corporate Governance Code of Japan that listed companies shall comply or explain.

The goal of the Guideline is to set a stable framework that allows actual or final beneficiaries domiciled outside of Japan to attend, raise questions, vote, or observe AGMs if they wish to do so. Most of non-resident shareholders hold stocks issued by Japanese companies through omnibus accounts registered in the name of their global custodian banks. Presently, most of Japanese listed companies limit the attendance to AGMs only to shareholders of record as usually specified in their Articles of Incorporation, thus effectively hindering most of foreign investors who hold shares in the above-mentioned manner to attend AGMs.

2. Four potential ways to attend an AGM

The Guideline first enumerates and explains the rules under the Companies Act of Japan as well as the Supreme Court precedents to help readers understand the established rules. Then provide four possible ways to enable non-registered investors to AGMs with certain legal basis because legal certainty is a key. If anyone who is not allowed exercising voting rights at AGM actually exercises voting rights for some reasons, which constitute a cause of action for legal proceedings to revoke a resolution of AGM.

The four ways in the Guideline are as follows:

A	To attend AGM as a shareholder and a proxy by becoming an actual holder of one or more trading unit as of its record date, then being appointed as a proxy of the whole position registered in the name of its global custodian on its behalf.
B	To attend AGM as just an observer by exercising its voting rights prior to AGM, and with condition that it will not exercise any shareholders rights at AGM.
C	To attend AGM as a proxy for the shareholder on the record by demonstrating the issuer "Special Circumstances" under the Supreme Court precedent, i.e., (i) attendance of the proxy will have no possibility of disturbance at the AGM and no harm to the issuers' interest; and (ii) the non-registered shareholder's voting rights will be substantially undermined if the exercise of voting rights as a proxy is not allowed.
D	To attend AGM as proxy for the shareholder on the record pursuant to the articles of incorporation of the issuer (e.g. the issuer shall amend its article of incorporation to provide this channel to investors)

An English translation of the Guideline is available at the website of Kabukon:

https://www.kabukon.tokyo/data/data/guidelines/guideline_2015_e.pdf

X. Cycle for entitlements: Comparison with other markets

Cash dividends are paid to entitled shareholders out of a company's current earnings or retained earnings. Dividends, which are taxable as income, are announced by the company's board of directors and are usually subject to shareholder approval in Japan.

Dividends are always paid in cash in the Japanese market.

A. Important dates for entitlements

1. Record date

The record date usually falls on the end and after the first half of the issuer's fiscal year. For most companies in Japan, the fiscal year ends on the last business day of March and the first fiscal half ends on the last business day of September. The shareholders list is compiled on the settlement status as of the record date, and shareholders need to be listed on the shareholders registry in order to be entitled.

2. Ex-date

This date is also known as the ex-dividend date. In the Japanese market, as the result of the implementation of equities T+2 settlement cycle on 16 July 2019, Ex-date has been shifted from "two business days before the record date" to "one business day before the record date". If a stock is bought on or after this date, the buyer is not entitled to the dividend. Also, even if a trade were made before the ex-date, the buyer would not be entitled if for any reason the trade was not settled by the record date.

Chart X-A-2: New Ex-date cycle (in accordance with T+2 settlement cycle)

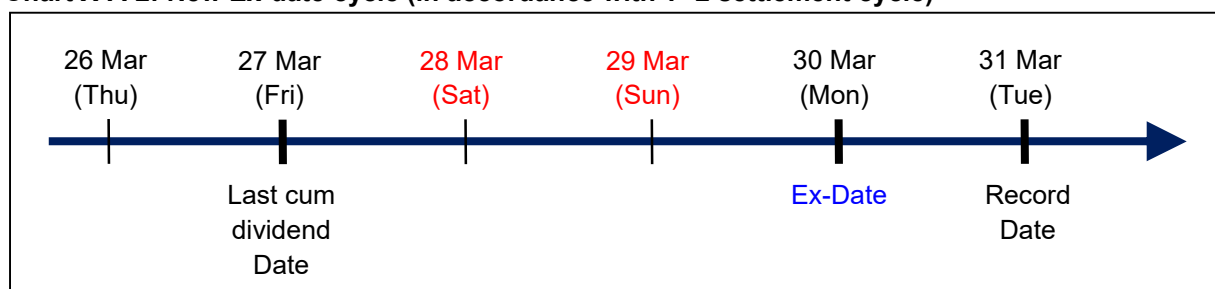

For reference purpose: Old cycle (before 16 July 2019, on T+3 basis)

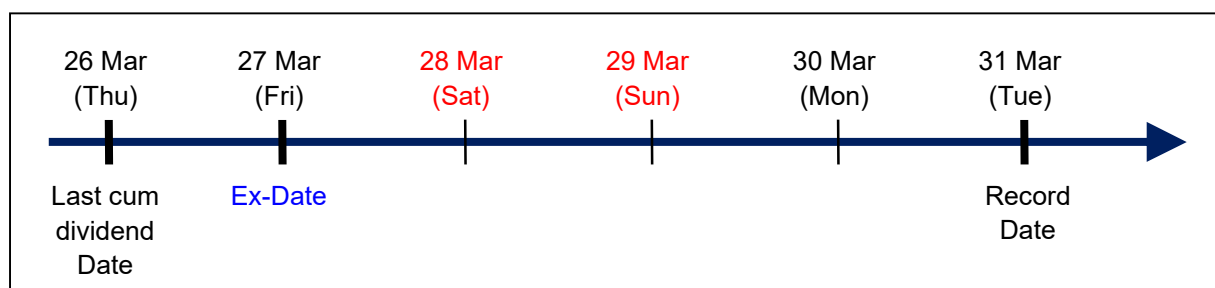

3. Pay date

The pay date is the day for dividends to be paid to entitled shareholders.

4. Announcement date

Listed companies announce their business results in accordance with the rules of the securities exchanges on which they are listed. Normally, they are required to make the announcement within two months of the record date. Since dividend policy is usually included in the announcement, details such as the dividends per share and pay date

become available on this date.

B. Comparison of dividend payment timeframes

1. Standard timeframe for dividend payment in Japan

To facilitate understanding of how the cycle for entitlements in the Japanese market differs from that of other markets, the typical cycle for dividends in the U.S. will also be cited for comparison. Most of the listed companies with a fiscal year ending 31 March listed on the Tokyo Stock Exchange announces their business results and dividend policy around 10 May. In these cases, the announcement takes 40 days from the record date. This is a common time frame in Japan.

Chart X-B-1: Standard cycle for listed companies in Japan

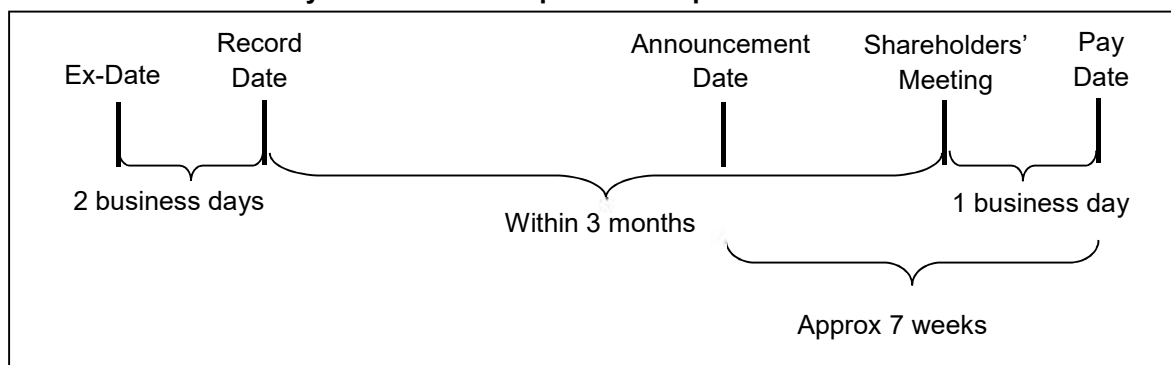

2. Standard timeframe for dividend payment in US

For the sake of comparison, General Electric of the US released its 2011 first quarter earnings on 21 April, but announced the details of its first quarter dividend on the earlier date of 11 February. The dividend was for shareholders of record on 28 February, and the pay date was 25 April.

Chart X-B-2: Standard cycle for listed companies in the US

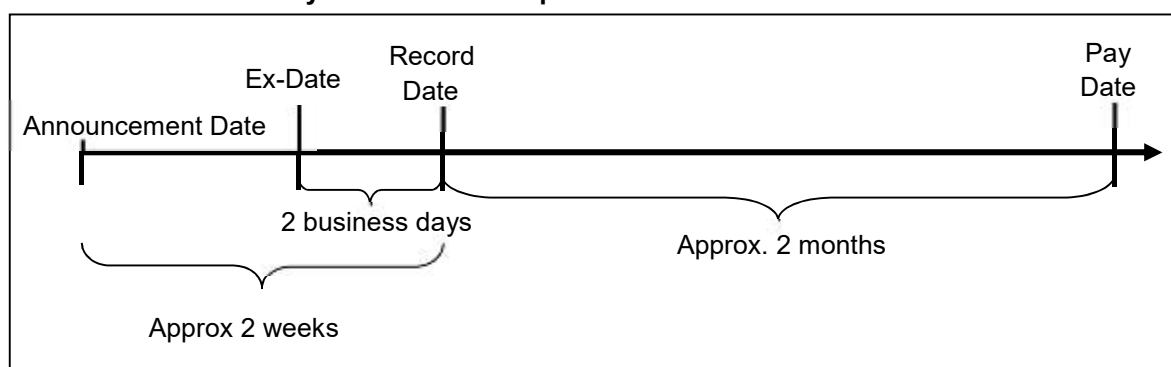

3. Comparison

As can be seen above, in Japan, a typical cycle for entitlements takes this form:

- 1) Ex-date (29 March)
- 2) Record date (31 March)
- 3) Announcement date (15 May)
- 4) Shareholders meeting (30 June)
- 5) Pay date (1 July)

In the case of the US, the announcement comes first, and the cycle is different to what is in place in Japan:

- 1) Announcement date (11 February)

- 2) Ex-date (24 February)
- 3) Record date (28 February)
- 4) Pay date (25 April)

4. Reasons for the difference

Difference in record dates for entitlements

Japanese issuing companies initiate procedures to close their books on the record date. Based on the record date, they calculate profits, decide their dividend policy, and determine eligibility for voting at the annual general meeting, which is generally held within three months from the record date. In the US, however, record dates for dividends have no bearing on voter eligibility. In other words, dividends and voting rights in Japan are usually both based on the record date, while US companies predominantly use a separate record date for dividends and voting rights.

Difference in procedures for approving dividends

Japanese law used to limit dividend payments to once or twice a year and stipulate that payments should be approved at a general shareholders meeting. In the US, dividend policy can be decided at the discretion of a company's board of directors. Although the new Japanese Companies Act allows directors of companies to approve dividend payments under certain conditions and removes limits on the number of times per year dividends are paid, most companies still adhere to dividends of either once or twice per year.

Possible reschedule of dividend payment date

In accordance with the joint announcement of JASDEC, Keidanren (Japan Federation of Economic Organizations, one of the major business lobbying group) and Kabukon (A study group of operations for equity issuance and management established by major issuers in Japan) in February 2016, a dividend payment date may be rescheduled if a shareholder proposal on the change of dividend unit price is submitted to annual general shareholders meeting (AGM).

In general operation practice model of dividend payment prior to the release of this model, it had been simply assumed that issuer's proposal on dividend unit price shall always be approved at AGM. This is why dividends are paid in most cases on the next business day of the AGMs, allowing all parties involved in the process to get prepared for the dividend payment in advance.

In order to reflect the market trend that some shareholders demands issuers to pay more dividends at AGMs, the new model practice suggests another time frame for dividend payment operations. In short, if a shareholder submits a proposal regarding the change of dividend unit price to the AGM, the issuer may reschedule its dividend payment date to seven days after the following days of the AGM.

Case study

Record date: March 31 | Meeting date: June 28 | Scheduled dividend payment date: June 29

In the above case, shareholders can find whether any proposal on dividend is included in the agenda, which is usually distributed to the shareholders about 2 weeks prior to the meeting date, in this case, possibly June 15 or 16.

When such a shareholders proposal is on the meeting agenda, Mizuho Bank will send notifications at the following timings to clients who are SWIFT users.

Notice	Trigger event
1 st MT564	An issuer announces confirmed dividend unit price and pay date
2 nd MT564 REPL	A shareholder proposal on dividend is discovered on the agenda
3 rd MT564 REPL	The final dividend unit price and pay date are confirmed

It should be noted that the rule is a suggested model practice, and has no binding effect.

XI. Account Opening Procedures at Mizuho Bank (MHBK)

A. Custody accounts

1. Main Account

First, customers must set up a main account with MHBK. Foreign entities are required to provide the following documents when setting up accounts with MHBK:

- (1) Custody agreement (to be signed by both parties)
- (2) Certificate of incorporation (document proving your status as incorporated entity outside of Japan)
- (3) A copy of a photo ID of a contact person at your institution (photocopy of passport or other ID showing person's name, address, and date of birth)
- (4) Power of attorney (POA) to prove MHBK's agency for corporate action-related procedures to local tax offices and/or issuers
- (5) List of authorized signatories
- (6) Debit authorization (for automatic payment of custody fees)
- (7) Account opening instruction (to confirm name of account)
- (8) Documents related to tax-exemption procedures; in the event that your clients are holding bonds that are eligible for tax exemption, Application Form for Withholding Tax Exemption/Notification is also necessary (see section VII for more information).
- (9) Application for transaction (the template available)
- (10) FATCA Self Certification Form
- (11) CRS (Jurisdiction of Residence for Tax Purposes) Self-Certification
- (12) Declaration Sheet for Person Holding Voting Power and the Right of Representation
- (13) Declaration Sheet for the Substantial Controller of Corporate Customers (Relationship Chart)

2. Sub-account

MHBK will open the main account upon confirming that the documents described above have been received in good order. When the customer wishes to open a sub-account, MHBK requires an account opening instruction via MT599. The instruction must provide the following information:

- (1) Name of the sub-account
- (2) Residency of the beneficial owners

3. "My Number" reporting requirement

In some cases, MHBK may require so-called "My Number," an unique tax identification number assigned to residents of Japan. However, clients are strongly requested to wait for specific instructions from us to avoid an unexpected breach of relevant laws.

The relevant Cabinet Order clearly states that AMIs shall handle "My Number" of individuals only via system located in Japan directly connected to CSD. In other words, any foreign account management institutions (FIAMIs) shall

NOT handle “My Number” of individuals in any system located outside of Japan, including but not limited to, email and file servers. Further, domestic AMIs shall not receive or send “My Number” of individuals via any electronic measures from the number holders. Therefore, “My Number” of any individual shall be domestically and directly sent from that individual to domestic AMI via registered postal mail.

B. Yen correspondent accounts

There are nine steps required to open a yen correspondent account with MHBK: *

- (1) Request Information on Account Opening
Generally speaking, only banks may open yen correspondent accounts.
- (2) Confirm whether bank has outstanding Relationship Management Application (RMA)
(If yes, skip to Step 6.)
If outstanding RMA is on file, account opening can proceed; otherwise, the customer must complete all necessary know-your-customer (KYC) and anti-money laundering (AML) procedures.
- (3) Receive, complete, and return MHBK Anti-money Laundering (AML) Survey
- (4) Review of AML Survey Response / Decision to Exchange RMA
(If AML survey responses are not acceptable, the account opening process is terminated.)
Upon review of the AML Survey Response, MHBK will determine whether to move forward with the application process. Should the necessary conditions be met, an exchange of RMA is conducted to establish a line of communications via SWIFT.
- (5) Confirmation of RMA Exchange
- (6) Exchange of Indicative Terms and Conditions (T&C) and related negotiations
Upon final agreement of the T&C, the formal request will be submitted by the customer.
- (7) Formal request via SWIFT to MHBK
The customer will send a formal request to MHBK (SWIFT BIC: MHCBJPJT) via SWIFT. Samples of such requests are available upon request.
- (8) Confirmation of receipt of necessary documents
MHBK will confirm receipt of the formal request SWIFT message and all other related documentation prior to carrying out the physical account opening and notify the customer of any problems.
- (9) Finalization of Account Opening
MHBK will notify the customer of the finalized relevant account details via SWIFT.

Note: The above steps are not definite, and actual account opening procedures may vary depending on the demands of the governing authorities.

C. Application of OECD CRS framework

In accordance with the international legal framework for automatic information exchange on financial accounts of non-residents with foreign tax administrations, Japan launched a new tax information reporting framework based on the Common Reporting Standard (CRS) approved by OECD and endorsed by G20 in September 2014. Circa 100 countries and regions declared to commence automatic information exchange in line with the CRS by the end of 2018 as of July 2016. Under the OECD CRS framework, reporting financial institutions will determine whether the account holder is a domestic resident or not for the tax purposes, and make necessary reporting to the domestic tax authority. The information to be reported includes name, address, country of residence, taxpayer identification number in the country of residence, account balance/value, total annual interest/dividends received. National tax authority of each country will exchange information with a foreign tax authority in accordance with tax treaties.

Pursuant to this international move, a new law was enacted in Japan to domestically implement the framework of

OECD CRS. Under the law, financial institutions such as banks and securities broker-dealers in Japan are required to report financial account information held by non-residents from 1 January 2017. Specifically, financial institutions in Japan shall identify the accounts subject to the reporting to Japan National Tax Agency, and applicants of financial account opening are required to submit self-declaration form to financial institution prior to opening a financial account (e.g., cash account, securities custodial account) with Japanese financial institution. The applicable law imposes certain penalty to Japan non-resident financial account holders for false reporting. Therefore, clients may be requested by the local agent bank to submit such self-declaration form for account opening going forward. For legal person, items that shall be reported through such self-declaration form include the name of legal entity, head office address, and country of domicile for the tax purpose.

For further details, please see the material prepared by National Tax Agency of Japan available at the following URL:
https://www.nta.go.jp/taxes/shiraberu/kokusai/crs/pdf/0021012-107_02.pdf

Japan Securities Dealers Association also issued a notice on this matter, and posted over their website at the following:
http://www.jsda.or.jp/en/activities/research-studies/files/161219_CRS_Eng.pdf

XII. Websites of relevant entities

Name	Website	Description
Bank of Japan (BOJ)	https://www.boj.or.jp/en/	Website provides news and statistics on its operations
Bank of Japan's book-entry system	https://www.boj.or.jp/en/paym/jgb_bes/index.htm/	Provides detailed description of BOJ's book-entry system
Financial Services Agency (FSA)	https://www.fsa.go.jp/en/	Website provides news on its activities and market developments in which agency is involved
FSA Foreign AMI Procedures	https://www.fsa.go.jp/en/laws_regulations/fami/index.html	Provides summary procedures, FAQs, and forms to apply to be a Foreign Account Management Institution
Fukuoka Stock Exchange (FSE)	https://www.fse.or.jp/english/	Website provides information about exchange and listed companies
Investment Trusts Association, Japan (JITA)	https://www.toushin.or.jp/english/	Works to protect investors and to contribute to sound development of investment trusts and investment companies; Website includes statistics on investment trusts in Japan
Japan Local Government Bond Association (JLGBA)	http://www.chihousai.or.jp/english/index.html	Promotes holding of Japanese local government bonds (municipal bonds); Website includes overview of local government bonds in Japan and instruction manual for non-residents seeking tax exempt status
Japan Securities Clearing Corporation (JSCC)	https://www.jpx.co.jp/jscc/en/index.html	Website includes information about operations, and clearing and settlement in Japan
Japan Securities Dealers Association (JSDA)	http://www.jsda.or.jp/en/index.html	Association for securities companies and dealers active in Japan; Website includes updates on its own activities and statistics
Japan Securities Depository Center (JASDEC)	https://www.jasdec.com/en/	Website includes information about its activities as the Central Securities Depository for stocks and bonds other than JGBs, and market statistics and data

Japanese Bankers Association (JBA)	https://www.zenginkyo.or.jp/en/	Members consist of banks, bank holding companies, and bankers associations in Japan; its functions include planning operation of payment systems and supporting banking businesses of member banks; website includes banking statistics and information on its activities.
Japan Exchange Group, Inc. (JPX)	https://www.jpx.co.jp/english/	Website of the parent company of the TSE and OSE; English website includes corporate information, news releases, and earnings data
Ministry of Finance (MOF)	https://www.mof.go.jp/english/index.htm	Website provides press releases on ministry activities, including news about double taxation treaties (DTTs) between Japan and other countries, and various market statistics
Ministry of Foreign Affairs of Japan (MOFA)	https://www.mofa.go.jp/index.html	Website provides press releases on the Japanese government's diplomatic activities, including news about DTTs
Mizuho Bank Custody Services	https://www.mizuhogroup.com/bank/what-we-do/custody	Our own custody website provides our clients with information on our custody services, as well as general market information and other updates
MOF JGB information site	https://www.mof.go.jp/english/jgbs/	JGB section of Ministry of Finance's website includes general information about JGBs, updates on developments affecting the JGB market, and comprehensive information about the market
Nagoya Stock Exchange (NSE)	http://www.nse.or.jp/e/index.html	Website provides information about the exchange and the companies listed on the exchange.
Osaka Exchange (OSE)	https://www.jpx.co.jp/english/derivatives/index.html	Website provides information about derivatives markets
Sapporo Securities Exchange (SSE)	https://www.sse.or.jp/	SSE's website provides information about exchange and listed companies <i>Japanese only</i>

Securities and Exchange Surveillance Commission (SESC)	https://www.fsa.go.jp/sesc/english/index.html	Website of the surveillance arm of FSA provides information about its activities and general surveillance policies
--	---	--

XIII. Timetable of recent/expected market developments

The following major market developments occurred in Japan in 2022-2024 or are expected to occur in the future.

Date	Development
4 April 2022	JPX restructured and consolidated its cash equity markets into three named Prime, Standard, and Growth
27 June 2022	ODX started operating the PTS, being the 3rd PTS after around 12 years
1 September 2022	Part of the amended Companies Act enforced (electronic distribution of shareholders meeting materials)
22 September 2022	JPX commenced technical demonstration project for carbon credit market (until 31 January 2023)
23 September 2022	OSE and TOCOM started derivative holiday trading
31 October 2022	TOPIX constituents that fail to meet the standard, categorized as “phased weighting reduction constituents”, started to reduce in 10 phases every quarter
1 December 2022	JSDA implemented fail charges for corporate bonds
14 December 2022	Skymark Airlines Inc. was added to the FOL list
5 June 2023	Tick size applicable to TOPIX 100 constituents will be applied to TOPIX Mid400 constituents
11 October 2023	TSE opens the carbon credit market
5 November 2024	TSE launches next generation core trading system “Arrowhead 4.0”
5 November 2024	TSE extends trading hour for 30 minutes
31 January 2025	TOPIX constituents categorized as “phased weighting reduction constituents” to be totally eliminated from TOPIX (phased weighting reduction ratio reaches nil).
19 January 2026	JASDEC to extend the JGB cut-off time for PSMS (from 12:20pm to 12:50pm)

Note: Financial Services Agency (FSA), International Financial Reporting Standards (IFRS), Tokyo Stock Exchange (TSE), Osaka Securities Exchange (OSE), Japan Securities Depository Center (JASDEC).

Information contained herein is derived from sources believed to be reliable. While due care has been exercised in preparing this information, Mizuho Bank, Ltd. makes no warranty, expressed or implied, regarding the accuracy, completeness or usefulness of this information, and Mizuho Bank, Ltd. assumes no liability with respect to consequences of relying on this information for investment or any other purposes.

Appendix: Standard Documents for Foreign Investors Opening Accounts and Applying for Tax Breaks in Japan

*This matrix is for your quick reference only. Please kindly contact Mizuho if you have any specific question.

(As of March 2021)

Investor Type	Investor's domicile	Type of Security	Documents necessary for account opening	Documents necessary for tax break	Notes
-Pension Fund	-US -UK -France -Netherland -Switzerland -Australia -Chile -Denmark -Iceland -Qatar -Russia	Shares	1. Account opening instruction (SWIFT/MT599) if a segregated account needs to be opened. 2. POA is necessary if the assets are registered only in the name of the beneficial owner through a FIAMI account.	To apply for the preferential tax rates offered by the relevant double tax treaty: -Form 1-2 -Form 17 -Certificate of residency (COR)	-COR must be submitted in every three years -Application shall be made every time when entitled to income
		Bonds	Account opening instruction for each beneficial owner (SWIFT/MT599)	1. To apply for the tax exemption under J-BIEM: -Application form for withholding tax exemption 2. To apply for the preferential tax rates offered by the relevant double tax treaty: -Form 2 -Form 17 -Certificate of residency (COR)	-If bonds are recorded in the name of a beneficial owner, POA is required when applying for tax break based on the relevant double tax treaty. -COR must be submitted in every three years -Application shall be made every time when entitled to income
-Individual -National government -Local authority -Central Bank -Publicly traded company or its subsidiary, or -Public service organization	US	Shares	1. Account opening instruction (SWIFT/MT599) if a segregated account needs to be opened. 2. POA is necessary if the assets are registered only in the name of the beneficial owner through a FIAMI account.	To apply for the preferential tax rates offered by the double tax treaty: -Form 1-2 -Form 17 -Certificate of residency (COR/IRS6166)	-COR must be submitted in every three years. -Application shall be made every time when entitled to income
		Bonds	Account opening instruction for each beneficial owner (SWIFT/MT599)	1. To apply for the tax exemption under J-BIEM: -Application form for withholding tax exemption 2. To apply for the preferential tax rates offered by the double tax treaty: -Form 2 -Form 17 -Certificate of residency (COR/IRS6166)	-If bonds are recorded in the name of a beneficial owner, POA is required when applying for tax break based on the relevant double tax treaty. -COR must be submitted in every three years. -Application shall be made every time when entitled to income
Mutual Funds and any other type of entity not categorized in the above	US qualified	Shares	1. Account opening instruction (SWIFT/MT599) if a segregated account needs to be opened. 2. POA is necessary if the assets are registered only in the name of the beneficial owner through a FIAMI account.	To apply for the preferential tax rates offered by the double tax treaty: -Form 1-2 -Form 17 -Certificate of residency (COR/IRS6166)	-COR must be submitted annually. -Application shall be made every time when entitled to income

Information contained herein is derived from sources believed to be reliable. While due care has been exercised in preparing this information, Mizuho Bank, Ltd. makes no warranty, expressed or implied, regarding the accuracy, completeness or usefulness of this information, and Mizuho Bank, Ltd. assumes no liability with respect to consequences of relying on this information for investment or any other purposes.

		Bonds	Account opening instruction for each beneficial owner (SWIFT/MT599)	<ol style="list-style-type: none"> To apply for the tax exemption under J-BIEM: -Application form for withholding tax exemption To apply for the preferential tax rates offered by the double tax treaty: -Form 2 -Form 17 -Certificate of residency (COR/IRS6166) 	<p>-If bonds are recorded in the name of a beneficial owner, POA is required when applying for tax break based on the relevant double tax treaty.</p> <p>-COR must be submitted annually.</p> <p>-Application shall be made every time when entitled to income</p>
Any other entities not categorized in the above	Other than US	Shares	<ol style="list-style-type: none"> Account opening instruction (SWIFT/MT599) if a segregated account needs to be opened. POA is necessary if the assets are registered only in the name of the beneficial owner through a FIAMI account. 	<p>To apply for the preferential tax rates offered by the relevant double tax treaty (if any) :</p> <p>-Form 1 -2(mandatory) -Form 17* (see below) -Certificate of residency** (see below)</p> <p>*May be required if country of domicile is either UK, France, Netherland, Switzerland, Australia, New Zealand</p> <p>**Required when seeking tax exemption under the relevant double tax treaty which came into effect on or after 1 April 2004</p>	<p>-COR must be submitted annually.</p> <p>-Application shall be made every time when entitled to income</p>
		Bonds	Account opening instruction for each beneficial owner (SWIFT/MT599)	<ol style="list-style-type: none"> To apply for the tax exemption under J-BIEM: -Application form for withholding tax exemption To apply for the preferential tax rates offered by the double tax treaty: -Form 2 (mandatory) -Form 17* (see below) -Certificate of residency** (see below) <p>*May be required if country of domicile is either UK, France, Netherland, Switzerland, Australia, New Zealand</p> <p>**Required when seeking tax exemption under the relevant double tax treaty which came into effect on or after 1 April 2004</p>	<ol style="list-style-type: none"> If bonds are recorded in the name of a beneficial owner, POA is required when applying for tax break based on the relevant double tax treaty. COR has to be submitted at the time of account opening.

Account opening instruction via MT599 must contain the following information

- i) Name of the beneficial owner
- ii) Legal domicile of the beneficial owner

For shares, an account opening instruction is not required if the assets are held in an omnibus account. Tax immunity for sovereign entities domiciled in countries that do not have a double tax treaty with Japan is not addressed in this table.