

2024-026-R-0004-A9



This document gives an overview of Taylor compatible inverters, and the procedure on how to connect the inverter to the Taylor Gateway.



Important The actions described in this manual should only be executed by trained professionals. Use this manual in combination with the inverter manual received with your inverter.

Table of contents

01	List of compatible inverters	2
02	Inverter to Gateway connection	3
03.1	Taylor inverters instructions	5
03.2	Verifying correct operation of Taylor inverters	12
03.3	AEG inverters instructions	14
03.4	Fox ESS inverters instructions	16
03.5	Goodwe inverters instructions	24
03.6	Solis inverters instructions	27
04	List of data cables	28

01 Compatible inverters

Taylor inverters

Taylor (produced by Fox ESS)
(page 5-11)

Taylor H1 series (page 5-8)

TAY-H1-3.0-E
TAY-H1-3.7-E
TAY-H1-4.6-E
TAY-H1-5.0-E
TAY-H1-6.0-E



Taylor H1-G2 series (page 5-8)

TAY-H1-3.0-E-G2
TAY-H1-3.7-E-G2
TAY-H1-4.6-E-G2
TAY-H1-5.0-E-G2
TAY-H1-6.0-E-G2



Taylor H1-G2-WL series (page 5-8)

TAY-H1-3.0-E-G2-WL
TAY-H1-3.7-E-G2-WL
TAY-H1-4.6-E-G2-WL
TAY-H1-5.0-E-G2-WL
TAY-H1-6.0-E-G2-WL



Taylor H3 series (page 9)

TAY-H3-5.0-E
TAY-H3-6.0-E
TAY-H3-8.0-E
TAY-H3-10.0-E
TAY-H3-12.0-E



Taylor H3 Pro / P3 Pro series (page 10)

TAY-P3-Pro-15.0
TAY-P3-Pro-20.0
TAY-P3-Pro-25.0
TAY-P3-Pro-30.0



Taylor P3-S series (page 11)

TAY-H3-P3-5.0-SH
TAY-H3-P3-6.0-SH
TAY-H3-P3-8.0-SH
TAY-H3-P3-9.9-SH
TAY-H3-P3-10.0-SH
TAY-H3-P3-12.0-SH
TAY-H3-P3-15.0-SH

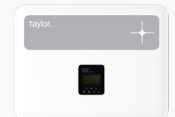

01 Compatible inverters

Other manufacturers

The inverters below are compatible with a Taylor system.
View the references on how to connect them.

[AEG \(page 14-15\)](#)

AEG AS-IC02

AEG AS-IC02-4000-2
AEG AS-IC02-5000-2
AEG AS-IC02-6000-2
AEG AS-IC02-8000-2
AEG AS-IC02-10000-2
AEG AS-IC02-12000-2
AEG AS-IC02-15000-2

AEG AS-IR02

AEG AS-IR02-700
AEG AS-IR02-1000
AEG AS-IR02-1500
AEG AS-IR02-2000
AEG AS-IR02-2500
AEG AS-IR02-3000

AEG AS-IR02-2

AEG AS-IR02-3000-2
AEG AS-IR02-3600-2
AEG AS-IR02-4200-2
AEG AS-IR02-5000-2
AEG AS-IR02-6000-2

[Fox ESS \(page 16-23\)](#)

Fox ESS H1 series

Fox ESS H1-3.0-E
Fox ESS H1-3.7-E
Fox ESS H1-4.6-E
Fox ESS H1-5.0-E
Fox ESS H1-6.0-E

Fox ESS H1-G2 series

Fox ESS H1-3.0-E-G2
Fox ESS H1-3.7-E-G2
Fox ESS H1-4.6-E-G2
Fox ESS H1-5.0-E-G2
Fox ESS H1-6.0-E-G2

Fox ESS H1-G2-WL series

Fox ESS H1-3.0-E-G2-WL
Fox ESS H1-3.7-E-G2-WL
Fox ESS H1-4.6-E-G2-WL
Fox ESS H1-5.0-E-G2-WL
Fox ESS H1-6.0-E-G2-WL

Fox ESS H3 series

Fox ESS H3-5.0-E
Fox ESS H3-6.0-E
Fox ESS H3-8.0-E
Fox ESS H3-10.0-E
Fox ESS H3-12.0-E

Fox ESS P3 Pro series

Fox ESS P3-Pro-15.0
Fox ESS P3-Pro-20.0
Fox ESS P3-Pro-25.0
Fox ESS P3-Pro-30.0

Fox ESS S series - G2

Fox ESS SG2 S700-G2
Fox ESS SG2 S1000-G2
Fox ESS SG2 S1500-G2
Fox ESS SG2 S2000-G2
Fox ESS SG2 S2500-G2
Fox ESS SG2 S3000-G2
Fox ESS SG2 S3300-G2

Fox ESS T series - G3

Fox ESS TG3 T3-G3
Fox ESS TG3 T4-G3
Fox ESS TG3 T5-G3
Fox ESS TG3 T6-G3
Fox ESS TG3 T8-G3
Fox ESS TG3 T10-G3
Fox ESS TG3 T12-G3
Fox ESS TG3 T15-G3
Fox ESS TG3 T17-G3
Fox ESS TG3 T20-G3
Fox ESS TG3 T23-G3
Fox ESS TG3 T25-G3

Fox ESS P3-S series

Fox ESS P3-5.0-SH
Fox ESS P3-6.0-SH
Fox ESS P3-8.0-SH
Fox ESS P3-9.9-SH
Fox ESS P3-10.0-SH
Fox ESS P3-12.0-SH
Fox ESS P3-15.0-SH

[Goodwe \(page 24-26\)](#)

Goodwe DNS D-NS

Goodwe DNS GW3000D-NS
Goodwe DNS GW3600D-NS
Goodwe DNS GW4200D-NS
Goodwe DNS GW5000D-NS
Goodwe DNS GW6000D-NS

Goodwe DNS T-DS

Goodwe DNS GW3000T-DS
Goodwe DNS GW3600T-DS
Goodwe DNS GW4200T-DS
Goodwe DNS GW5000T-DS
Goodwe DNS GW6000T-DS

Goodwe SDT G2 Plus

Goodwe GW4000-SDT-20
Goodwe GW5000-SDT-20
Goodwe GW6000-SDT-20
Goodwe GW8000-SDT-20
Goodwe GW10K-SDT-20
Goodwe GW12K-SDT-20
Goodwe GW15K-SDT-20

Goodwe XS

Goodwe XS GW700-XS
Goodwe XS GW1000-XS
Goodwe XS GW1500-XS
Goodwe XS GW2000-XS
Goodwe XS GW2500-XS
Goodwe XS GW3000-XS

[Solis \(page 27\)](#)

Solis Mini S5-GR1P(0.7-3.6)K-M

Solis S5-GR1P0.7K-M
Solis S5-GR1P1K-M
Solis S5-GR1P1.5K-M
Solis S5-GR1P2K-M
Solis S5-GR1P2.5K-M
Solis S5-GR1P3K-M
Solis S5-GR1P3.6K-M

Solis Mini S6-GR1P(0.7-3.6)K-M

Solis S6-GR1P 0.7K-M
Solis S6-GR1P 1K-M
Solis S6-GR1P 1.5K-M
Solis S6-GR1P 2K-M
Solis S6-GR1P 2.5K-M
Solis S6-GR1P 3K-M
Solis S6-GR1P 3.6K-M

Solis S5-EH1P(3.6-6)K-L

Solis S5-EH1P3.6K-L
Solis S5-EH1P3K-L
Solis S5-EH1P4.6K-L
Solis S5-EH1P5K-L
Solis S5-EH1P6K-L

Solis S5-GC(25-40)K

Solis S5-GC 25K
Solis S5-GC 30K
Solis S5-GC 33K
Solis S5-GC 36K
Solis S5-GC 40K

Solis S5-GR1P(2.5-6)K

Solis S5-GR1P 2.5K

Solis S5-GR1P 3K
Solis S5-GR1P 3.6K
Solis S5-GR1P 4K
Solis S5-GR1P 4.6K
Solis S5-GR1P 5K
Solis S5-GR1P 6K

Solis S5-GR3P(3-25)K

Solis S5-GR3P3K
Solis S5-GR3P4K
Solis S5-GR3P5K
Solis S5-GR3P6K
Solis S5-GR3P8K
Solis S5-GR3P9K
Solis S5-GR3P10K
Solis S5-GR3P12K
Solis S5-GR3P13K
Solis S5-GR3P15K
Solis S5-GR3P17K
Solis S5-GR3P20K

Solis S6-GR1P(2.5-6)K

Solis S6-GR1P 2.5K
Solis S6-GR1P 3K
Solis S6-GR1P 3.6K
Solis S6-GR1P 4K
Solis S6-GR1P 4.6K
Solis S6-GR1P 5K
Solis S6-GR1P 6K

Solis S6-GR1P(7-8)K2

Solis S6-GR1P 7K2
Solis S6-GR1P 8K2

Solis 3P(3-20)K-4G

Solis 3P3K-4G
Solis 3P4K-4G
Solis 3P5K-4G
Solis 3P6K-4G
Solis 3P8K-4G
Solis 3P9K-4G
Solis 3P10K-4G
Solis 3P12K-4G
Solis 3P15K-4G
Solis 3P17K-4G
Solis 3P20K-4G

02 Inverter to Gateway connection

Between the Gateway and the inverter a communication cable needs to be connected.

Gateway communication cable

Connect the communication cable to the RJ11 port of the Taylor Gateway and the COM-port of the inverter, according to the illustration.

Gateway power cable (included with Gateway 2E)

Use the supplied USB cable to power the Gateway directly from the inverter, or use the supplied power adapter with a standard power outlet.

! *Important* Do not turn the inverter on or off in case the Gateway is powered on.

Important The Gateway power cable is not waterproof. If required, please contact Taylor support.

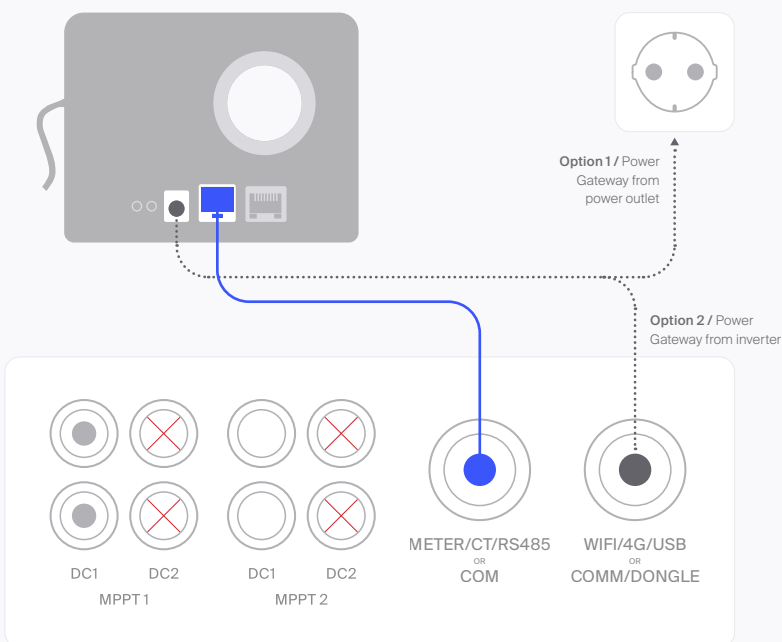

Gateway RJ11 connector

On one side, the cable is connected to the Gateway using a RJ11 connector, the other side is connected to the inverter. The cable can be ordered, or assembled by the installer. If done by the installer himself/herself, make sure the RJ11 connector pin out is as depicted on the right, using the instructions below.

RJ11 PIN	Wire colour	Function
1	Yellow	N/A
2	Green	RS485-
3	Red	RS485+
4	Black	GND

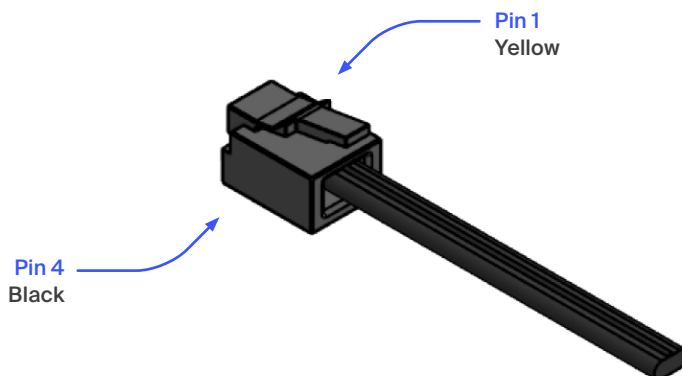

! *Important* Note that the pin out color code is different compared to standard RJ11 pin out.

03.1 Taylor inverters instructions

Taylor H1 / H1-G2 / H1-G2-WL series with CT clamp (produced by Fox ESS)

Necessary items

A. Data cable

Part number:

H1 / H1-G2: TAYLOR-GTW-C-H1-EC.

H1-G2-WL: TAYLOR-GTW-C-H1-EW.

Instructions

01.

Connect the current transducer to connector (A):

- Current transducer red wire > pin 1 on connector (A)
- Current transducer black wire > pin 2 on connector (A)



Important The current transducer should have the arrow pointing towards the grid, otherwise the import/export values will not be valid. Refer to inverter technical documentation.

02.

Connect connector (A) and connector (B) to complete the data cable.

03.

Connect connector (C) to port (E) of the inverter and the RJ11 connector (D) to the Gateway data port.

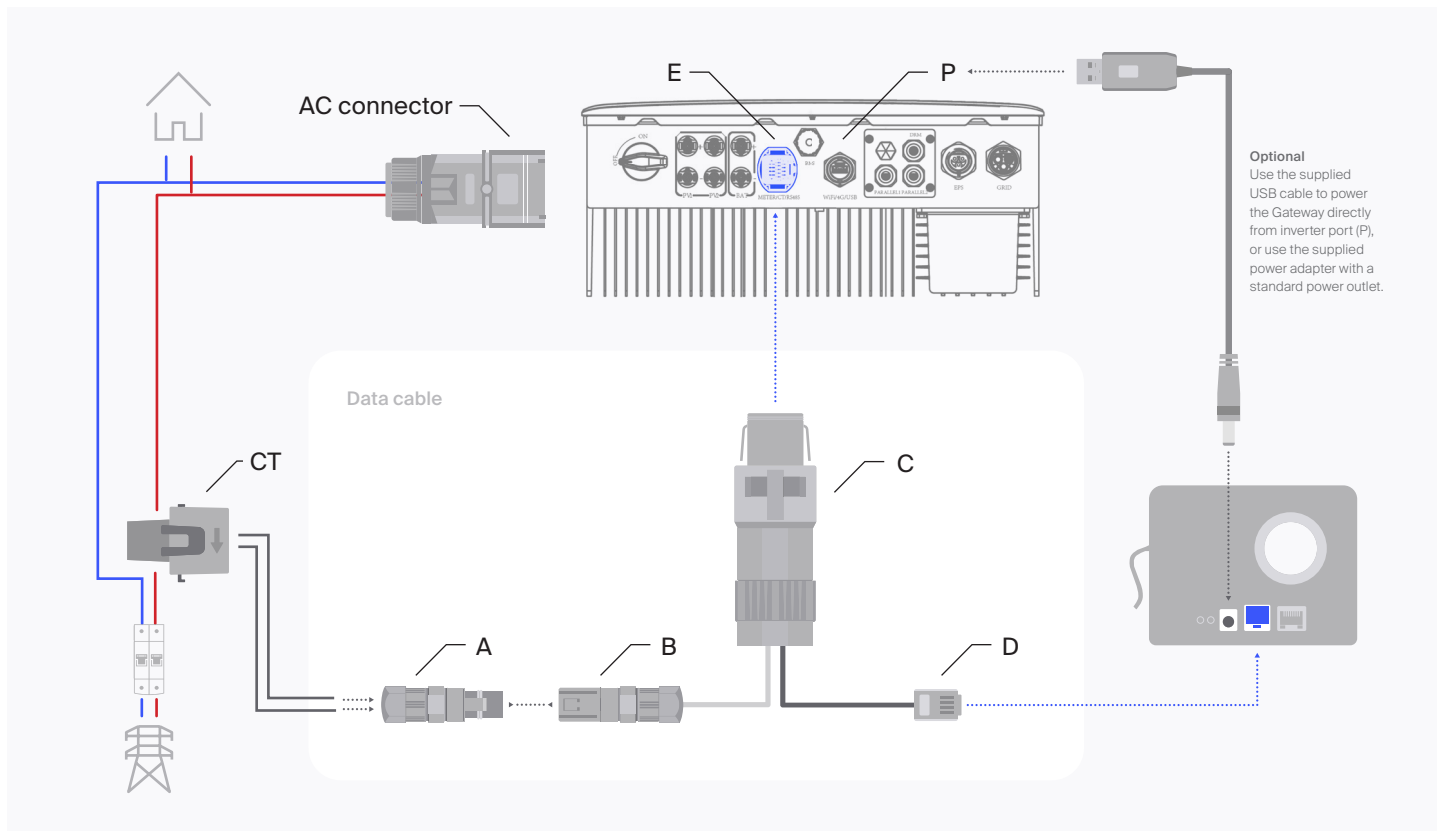

03.1 Taylor inverters instructions

Taylor H1 / H1-G2 / H1-G2-WL series with 1-phase energy meter

(produced by Fox ESS)

Necessary items

A. Data cable

Part number:

H1 / H1-G2: TAYLOR-GTW-C-H1-E.

H1-G2-WL: TAYLOR-GTW-C-H1-EWE.

B. Energy meter

Order separately from the Gateway / inverter.

Instructions

01. Consult the schematic to install a single phase AC system to a smart meter.
02. Connect the energy meter to connector (A):
 - Pin 24 on energy meter > pin 1 on connector (A)
 - Pin 25 on energy meter > pin 2 on connector (A)
03. Connect connector (A) and connector (B) to complete the data cable.
04. Connect connector (C) to port (E) of the inverter and the RJ11 connector (D) to the Gateway data port.
05. When installing the inverter, configure the inverter settings to 1-phase energy meter: *Setting > Feature > Meter/CT > Meter_1p*

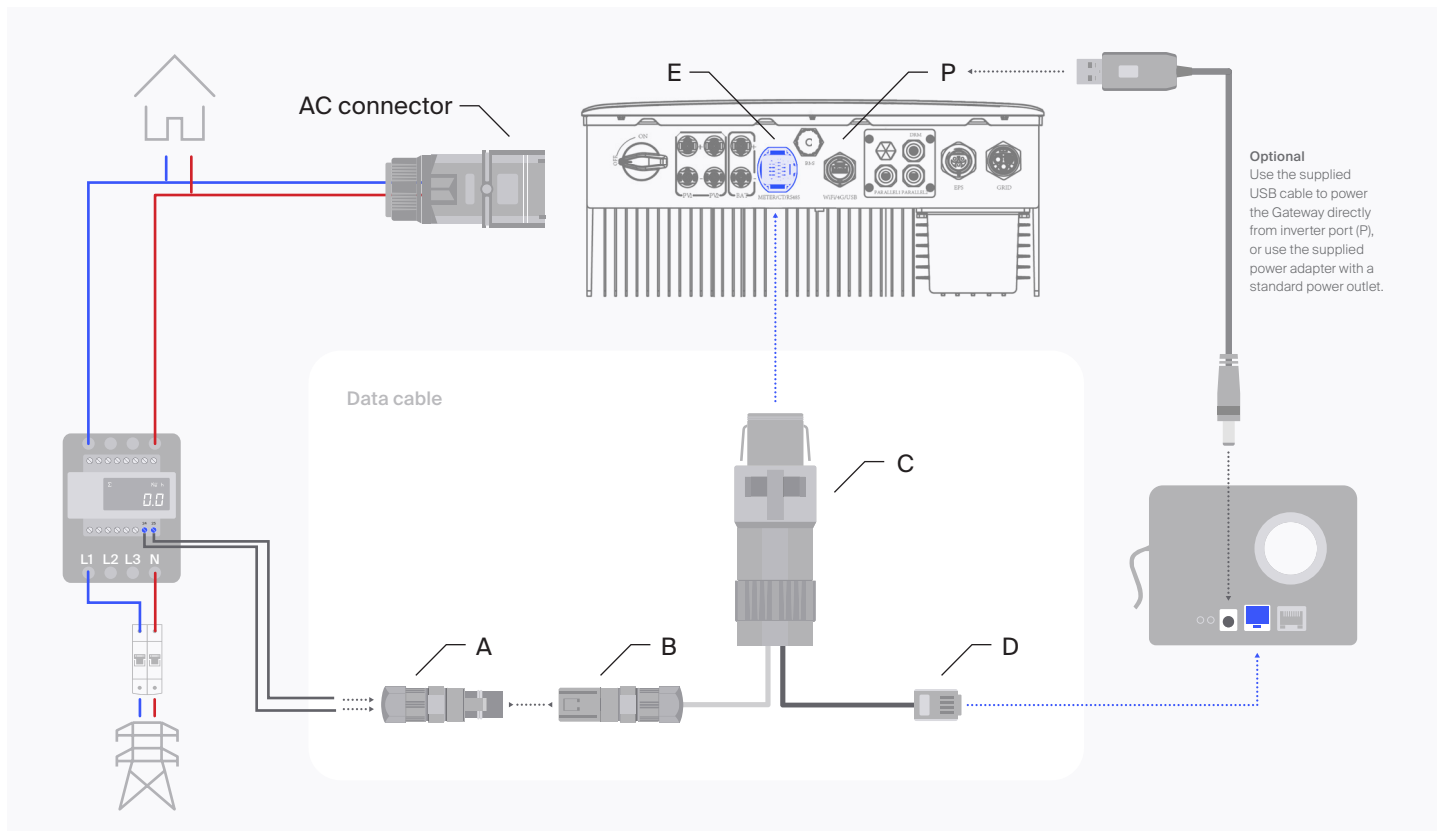

03.1 Taylor inverters instructions

Taylor H1 / H1-G2 / H1-G2-WL series in a 3-phase system

(produced by Fox ESS)

Necessary items

A. Data cable

Part number:

H1 / H1-G2: TAYLOR-GTW-C-H1-E.

H1-G2-WL: TAYLOR-GTW-C-H1-EWE.

B. Energy meter

Order separately from the Gateway / inverter.

Instructions

01. Consult the schematic to install a single phase AC system to a smart meter.
02. Connect the energy meter to connector (A):
 - Pin 24 on energy meter > pin 1 on connector (A)
 - Pin 25 on energy meter > pin 2 on connector (A)
03. Connect connector (A) and connector (B) to complete the data cable.
04. Connect connector (C) to port (E) of the inverter and the RJ11 connector (D) to the Gateway data port.
05. When installing the inverter, configure the inverter settings to 3-phase energy meter: *Setting > Feature > Meter/CT > Meter_3p*

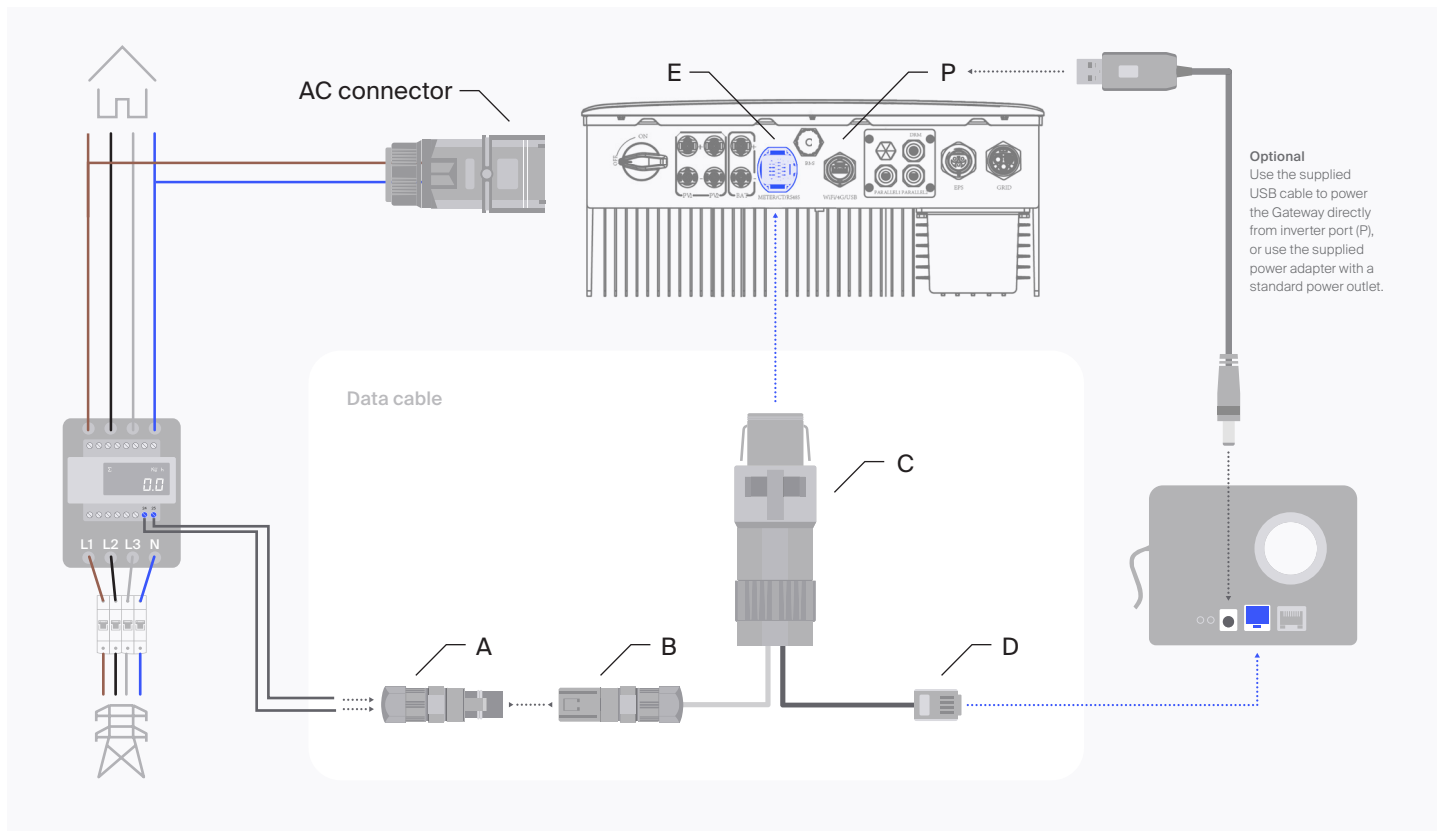

03.1 Taylor inverters instructions

Taylor H1 / H1-G2 / H1-G2-WL series in a 3-phase system with Delta grid

(produced by Fox ESS)

Necessary items

A. Data cable

Part number:

H1 / H1-G2: TAYLOR-GTW-C-H1-E.

H1-G2-WL: TAYLOR-GTW-C-H1-EWE.

B. Energy meter

Order separately from the Gateway / inverter.

Instructions

01. Consult the schematic to install a single phase AC system to a smart meter.
02. Adjust the smart meter settings to Delta grid, using the following sequence:
 - A) Press "set", change the code to 701
 - B) Navigate to CT using the set command
 - C) Press the arrow command four times until "net" appears
 - D) Set the net setting to n33 and confirm by pressing set again
03. Connect the energy meter to connector (A):
 - Pin 24 on energy meter > pin 1 on connector (A)
 - Pin 25 on energy meter > pin 2 on connector (A)
04. Connect connector (A) and connector (B) to complete the data cable.
05. Connect connector (C) to port (E) of the inverter and the RJ11 connector (D) to the Gateway data port.
06. When installing the inverter, configure the inverter settings to 3-phase energy meter: *Setting > Feature > Meter/CT > Meter_3p*

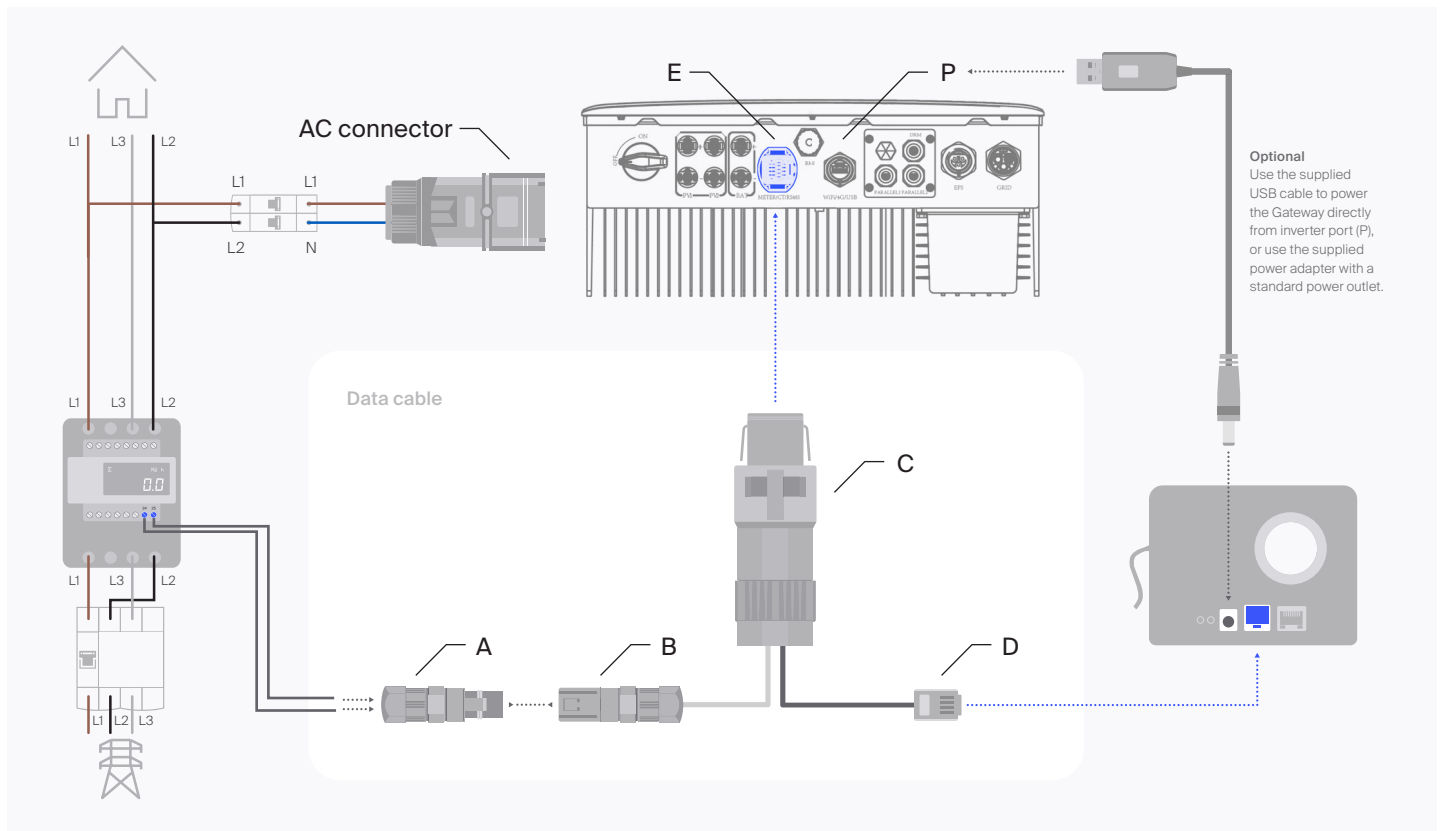

03.1 Taylor inverters instructions

Taylor H3 series (produced by Fox ESS)

Necessary items

A. Data cable

Part number: TAYLOR-GTW-C-H3-E.

Instructions

01.

Connect the energy meter to connector (A):

- Pin 24 on energy meter > pin 1 on connector (A)
- Pin 25 on energy meter > pin 2 on connector (A)

02.

Connect connector (A) and connector (B) to complete the data cable.

03.

Connect connector (C) to port (J) of the inverter and the RJ11 connector (D) to the Gateway data port.

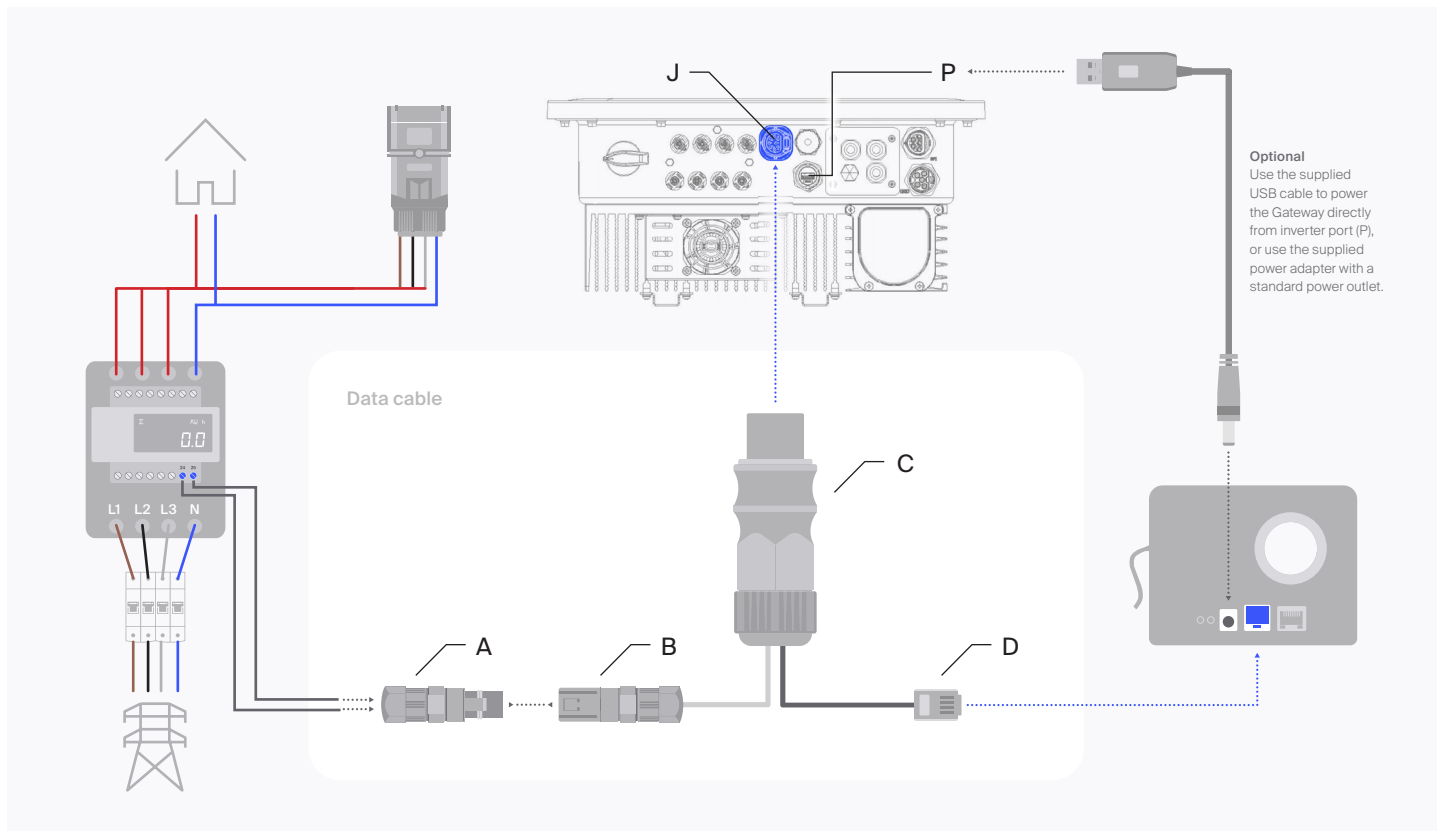

03.1 Taylor inverters instructions

Taylor H3 Pro / P3 Pro series (produced by Fox ESS)

Necessary items

A. Data cable

Part number: TAYLOR-GTW-C-H3-EP.

Instructions

01.

Connect the energy meter to connector (A):

- Pin 24 on energy meter > pin 1 on connector (A)
- Pin 25 on energy meter > pin 2 on connector (A)

02.

Connect connector (A) and connector (B) to complete the data cable.

03.

Connect connector (C) to port (K) of the inverter and the RJ11 connector (D) to the Gateway data port.

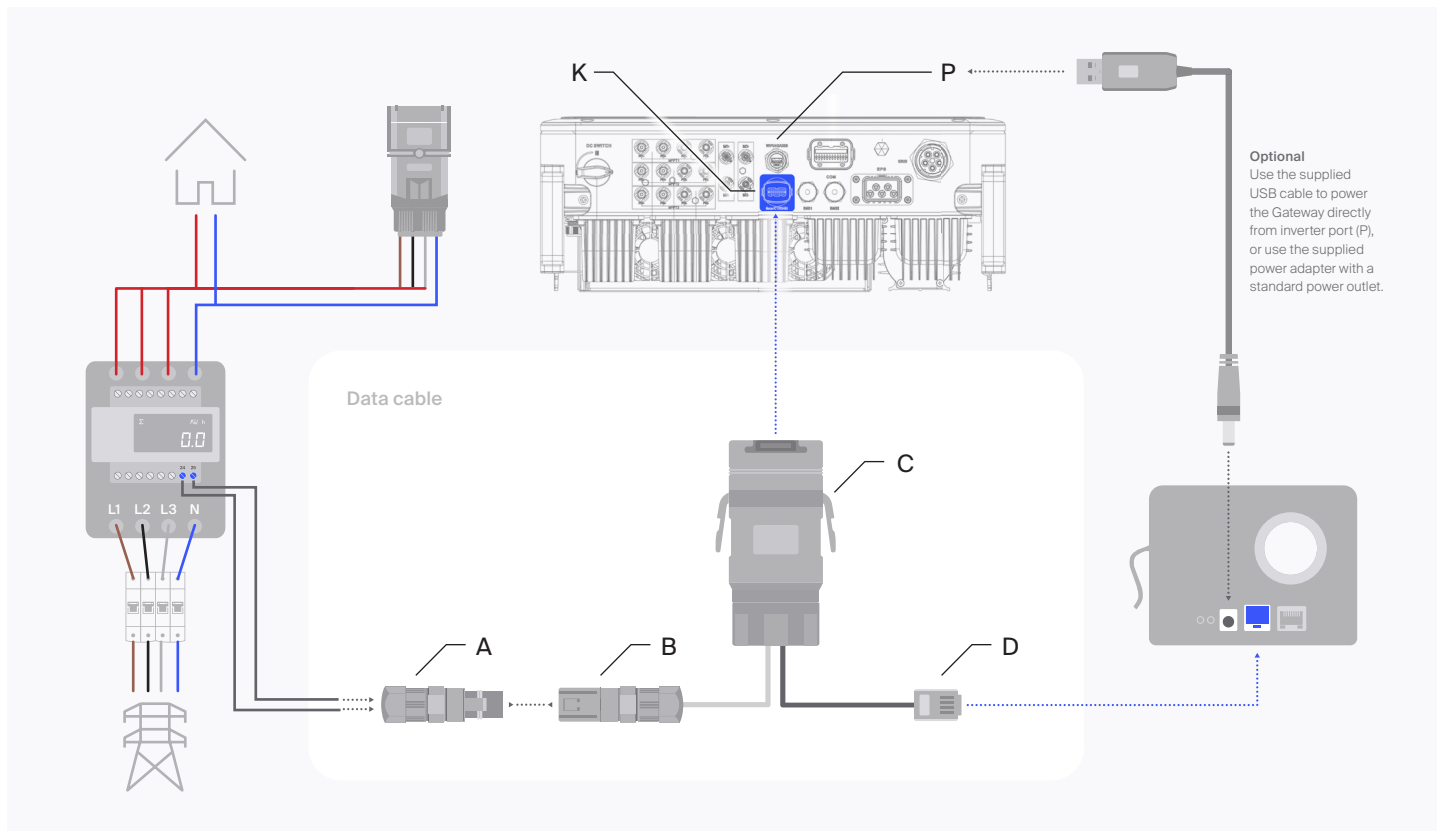

03.1 Taylor inverters instructions

Taylor P3-S series (produced by Fox ESS)

Necessary items

A. Data cable

Part number: TAYLOR-GTW-C-H3-ES

Instructions

01.

Connect the energy meter to connector (A):

- Pin 24 on energy meter > pin 1 on connector (A)
- Pin 25 on energy meter > pin 2 on connector (A)

02.

Make sure to not connect any other devices to pin 24 and 25 on the energy meter.

03.

Connect connector (A) and connector (B) to complete the data cable.

04.

Connect connector (C) to port (J) of the inverter and the RJ11 connector (D) to the Gateway data port.

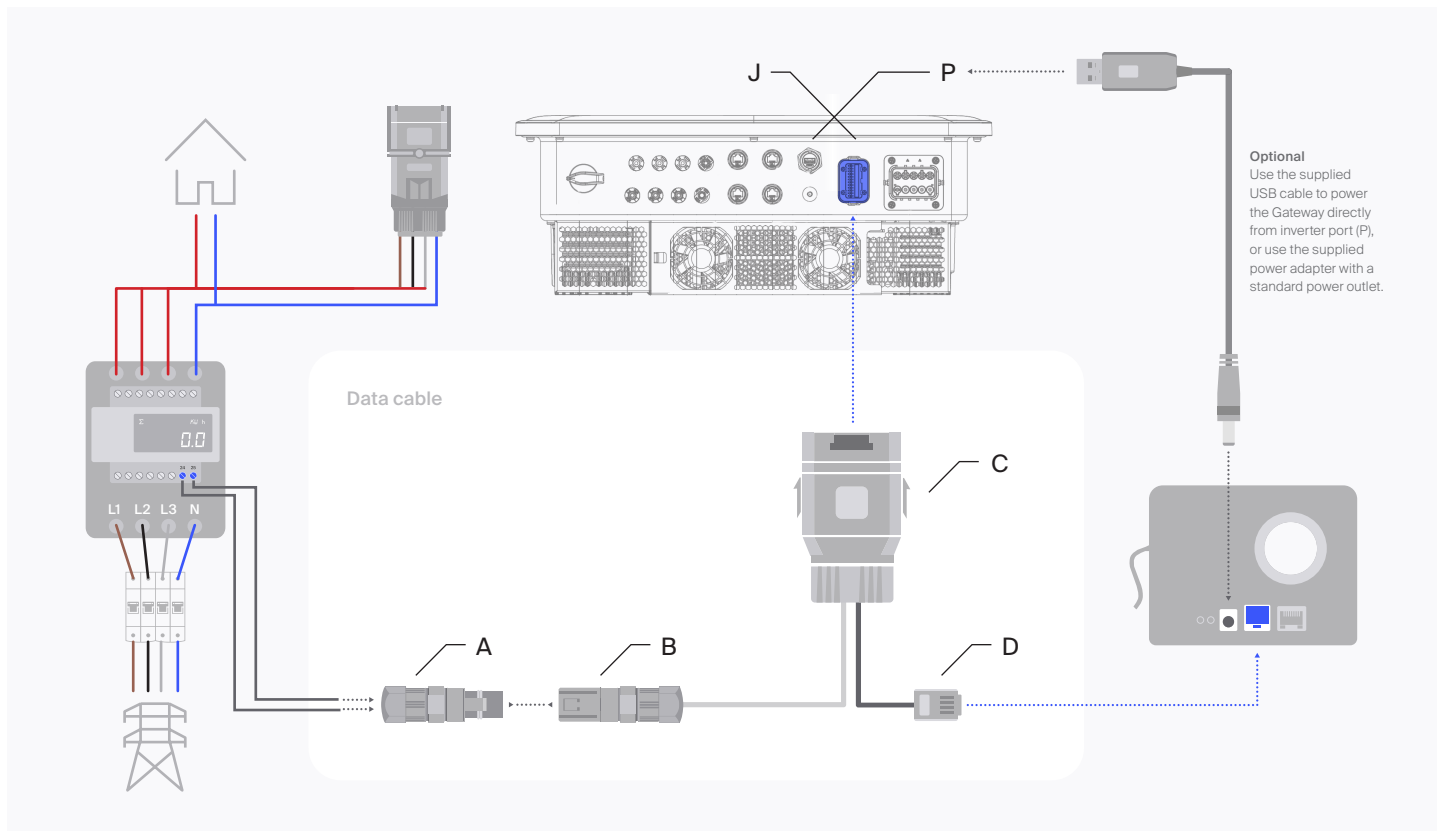

03.2 Verifying correct operation of Taylor inverter

When setting up a hybrid solar inverter system, it is crucial to ensure that the current transformer (CT clamp) or external energy meter is correctly installed. The CT clamp or energy meter must measure the total energy consumption and the feed-in of the consumer and must therefore be placed directly after the main switch.

Verification method 1 - Self-test function of the inverter

- | | |
|--|---|
| <p>01.
Open the menu of the inverter</p> <p>02.
Go to <i>Settings</i></p> <p>03.
Go to <i>Feature</i></p> <p>04.
Go to <i>Meter/CT</i></p> | <p>05.
Check if the correct setting is selected:
a) When using a CT clamp → CT
b) When using an energy meter → Energy meter</p> <p>06.
After the system has been connected for at least one minute, choose the option <i>Check</i> in this menu</p> |
|--|---|

Result H1 with CT

There are three possible outcomes:

1. Connect OK

The system is correctly connected

2. Connect Err

the CT clamp is connected in the wrong direction and must be reversed

3. Unknown state

- a) the connection between inverter and meter is incorrect or the battery is not properly connected
- b) The self-test is carried out without selecting whether a CT clamp
- c) The self-test is carried out but the chosen option (CT or energy meter) does not correspond to the connected component

Result inverter with energy meter

There are two possible outcomes:

1. Connect OK

the system is correctly connected

2. Unknown state

- a. The connection between inverter and meter is incorrect or the battery is not properly connected
- b. The self-test is carried out without selecting whether a CT clamp or energy meter is used
- c. The self-test is carried out but the chosen option (CT or energy meter) does not correspond to the connected component

Verification method 2 - Comparing inverter energy meter values with smart meter

01.

Compare the measurements

A.

Check the recorded power on the inverter display.

For Taylor inverters: Menu --> System/Running --> Grid

B.

At the same time, view the current consumption on the smart meter (if it has a display). Use the control button to switch to the correct screen and check whether it concerns import or export.

C.

Understand the import/export symbols of the inverter.

For Taylor inverters:

I. Export to the grid: positive value “+”

II. Import from the grid: negative value “-”

02.

Assess the difference

A.

The measurements should largely match in terms of power (kW) or energy consumption (kWh).

A small difference (within 5–10%) is acceptable due to delay, rounding, or internal processing.

B.

Both measurements must indicate the same energy flow direction: Import or Export (Import when there is no solar production and load is switched on).

03.

If the values differ significantly or show opposite directions (e.g., inverter shows export while smart meter shows import), the installation of the CT clamp or energy meter must be checked.

A.

Ensure that the CT clamp or energy meter is placed in the correct location

B.

Check whether the CT clamp is installed on the correct wire (usually the incoming phase wire) and pointing in the correct direction (according to the manufacturer's instructions; for Taylor inverters the arrow must point to the grid).

C.

Check whether the communication cable between CT clamp or energy meter is correctly connected to the inverter (refer to the manual).

03.3 AEG inverters instructions

AEG AS-IC02 & AS-IR02

Necessary items

- A. Data cable**
*Part number: TAYLOR-GTW-C-03.
Order separately from the Gateway.*
- B. Communication Connector**
Delivered with the inverter.

Instructions

- 01.**
Route the taylor data cable through the cable gland (A)
- 02.**
Connect the data cable to part A, refer to the table:

Wire	Wire colour	Connect to pin
	Yellow	Not connected
-	Green	1
+	Red	3
	Black	Not connected

- 03.**
Assemble the connector.
- 04.**
Connect the data cable to the COM port (B).

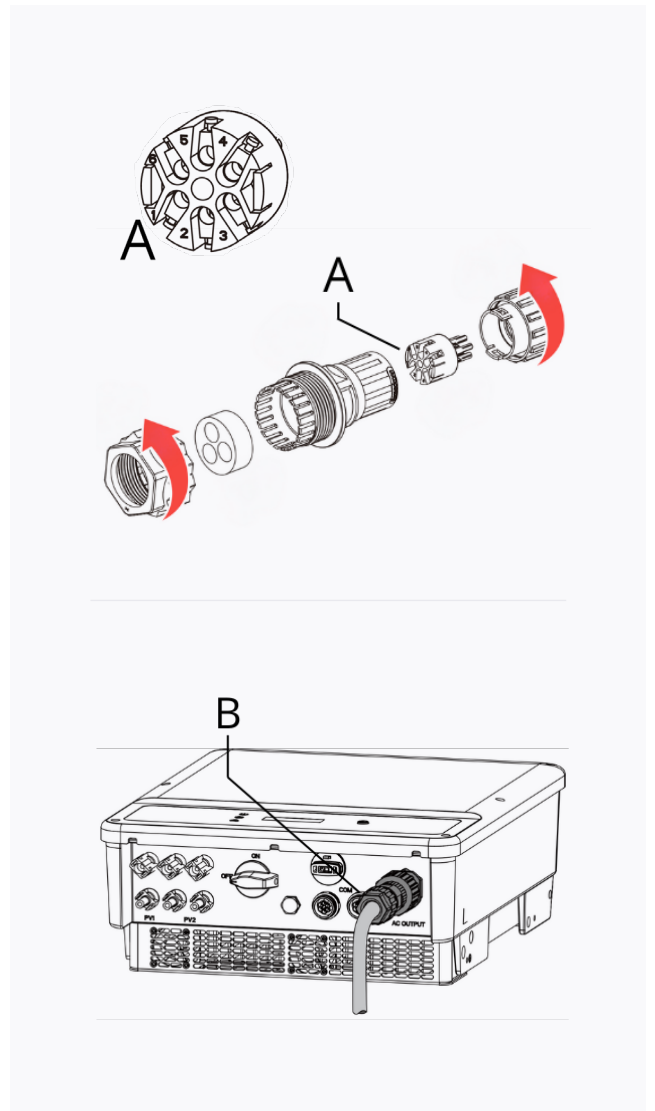

03.3 AEG inverters instructions

AEG AS-IR02-2

Necessary items

A. Data cable

Part number: TAYLOR-GTW-C-03.
Order separately from the Gateway.

Instructions

- 01. Demount the RS485 board from the inverter.
- 02. Pull the cable through the screwcap & RS485 board.
- 03. Connect it onto the lock - using the table below.

Wire	Wire colour	Connect to pin
	Yellow	Not connected
-	Green	2
+	Red	1
	Black	Not connected

- 04. Mount the RS485 board back as depicted on the right.

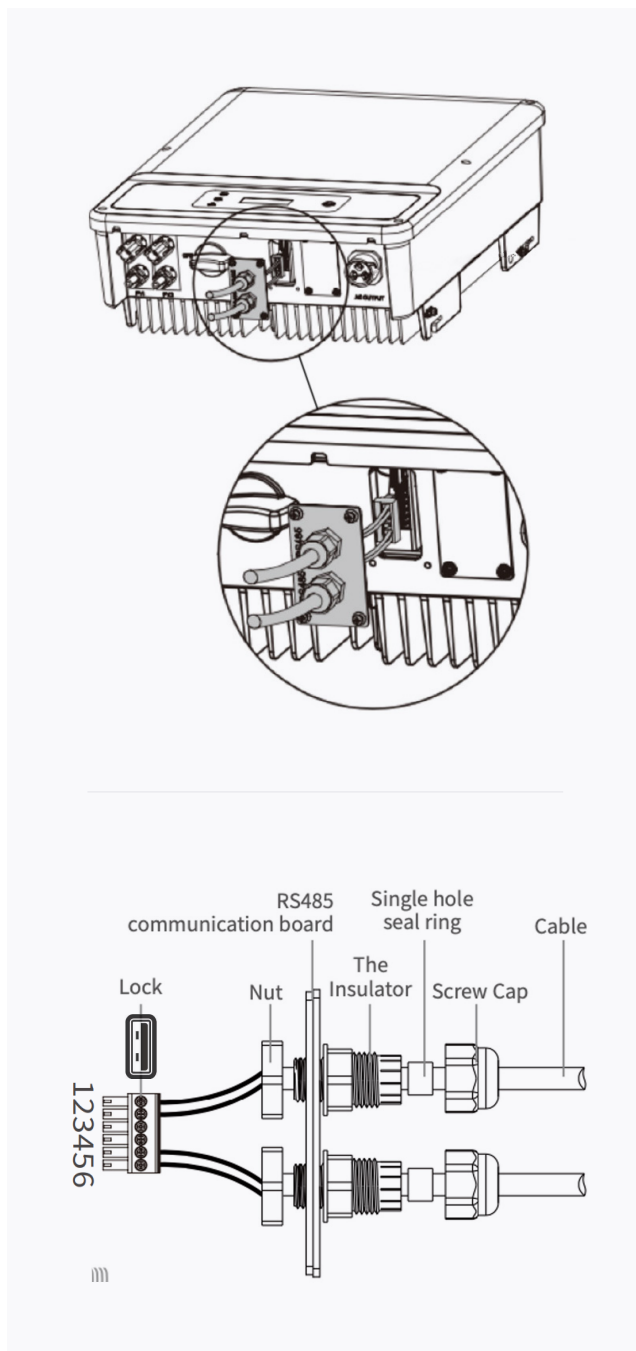

03.4 Fox ESS inverters instructions

Fox ESS H1 / H1-G2 / H1-G2-WL series with CT clamp

Necessary items

A. Data cable

Part number:

H1 / H1-G2: TAYLOR-GTW-C-H1-EC.

H1-G2-WL: TAYLOR-GTW-C-H1-EW.

Instructions

01.

Connect the current transducer to connector (A):

- Current transducer red wire > pin 1 on connector (A)
- Current transducer black wire > pin 2 on connector (A)



Important The current transducer should have the arrow pointing towards the grid, otherwise the import/export values will not be valid. Refer to inverter technical documentation.

02.

Connect connector (A) and connector (B) to complete the data cable.

03.

Connect connector (C) to port (E) of the inverter and the RJ11 connector (D) to the Gateway data port.

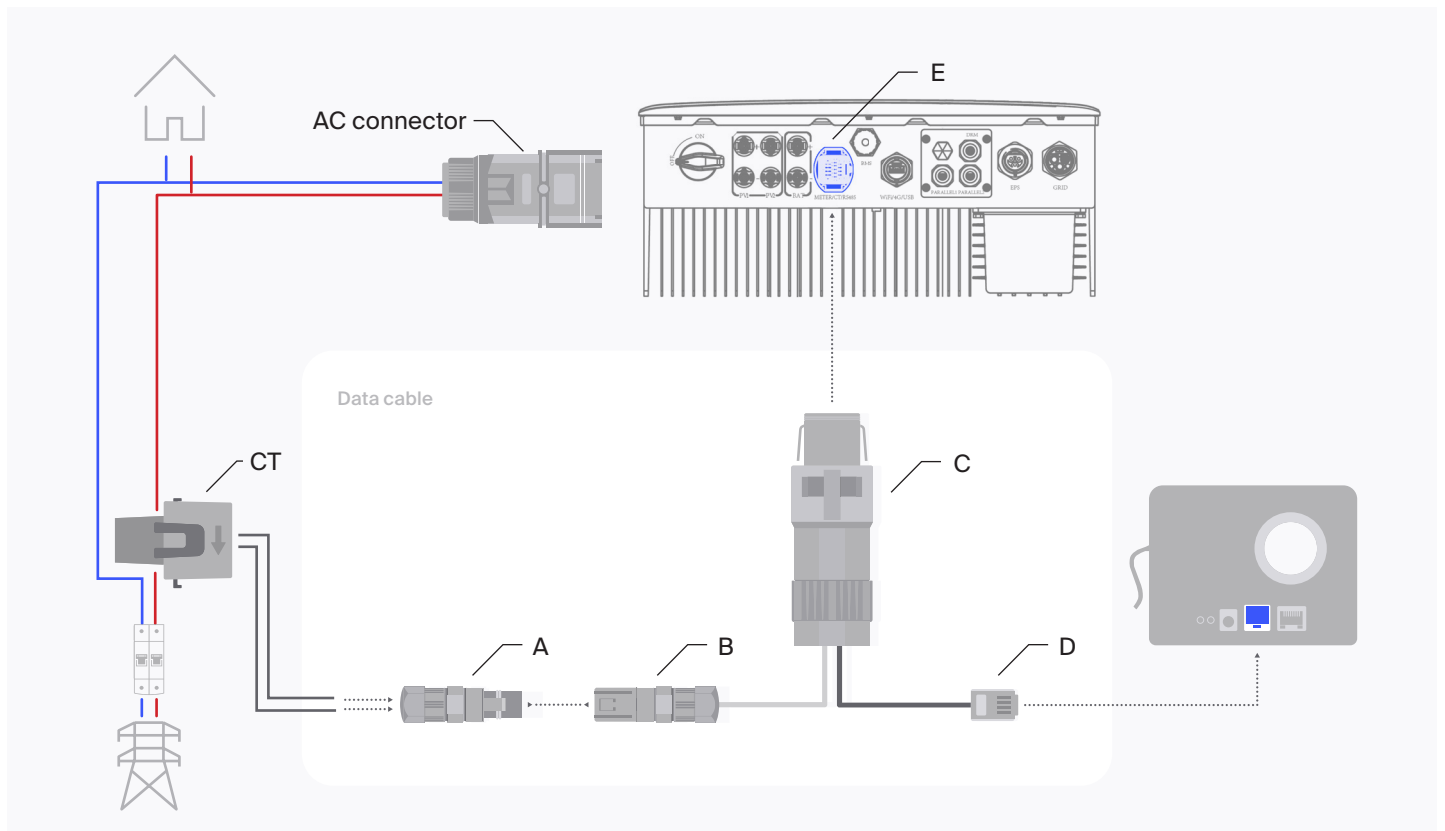

03.4 Fox ESS inverters instructions

Fox ESS H1 / H1-G2 / H1-G2-WL series with 1-phase energy meter

Necessary items

A. Data cable

Part number:

H1 / H1-G2: TAYLOR-GTW-C-H1-E.

H1-G2-WL: TAYLOR-GTW-C-H1-EWE.

B. Energy meter

Order separately from the Gateway / inverter.

Instructions

01. Consult the schematic to install a single phase AC system to a smart meter.
02. Connect the energy meter to connector (A):
 - Pin 24 on energy meter > pin 1 on connector (A)
 - Pin 25 on energy meter > pin 2 on connector (A)
03. Connect connector (A) and connector (B) to complete the data cable.
04. Connect connector (C) to port (E) of the inverter and the RJ11 connector (D) to the Gateway data port.
05. When installing the inverter, configure the inverter settings to 1-phase energy meter:
Setting > Feature > Meter/CT > Meter_1p

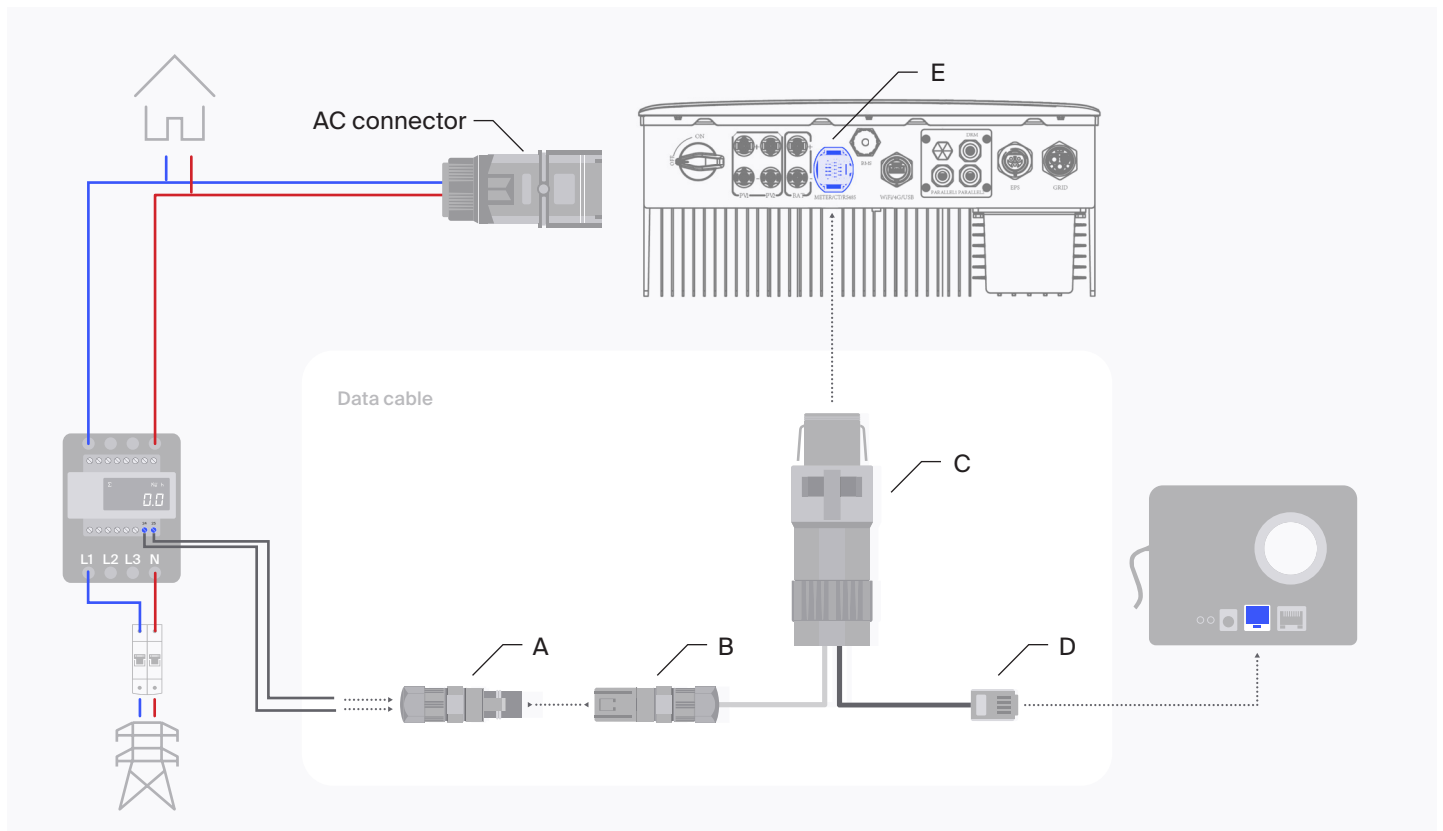

03.4 Fox ESS inverters instructions

Fox ESS H1 / H1-G2 / H1-G2-WL series in a 3-phase system

Necessary items

A. Data cable

Part number:

H1 / H1-G2: TAYLOR-GTW-C-H1-E.

H1-G2-WL: TAYLOR-GTW-C-H1-EWE.

B. Energy meter

Order separately from the Gateway / inverter.

Instructions

01. Consult the schematic to install a single phase AC system to a smart meter.
02. Connect the energy meter to connector (A):
 - Pin 24 on energy meter > pin 1 on connector (A)
 - Pin 25 on energy meter > pin 2 on connector (A)
03. Connect connector (A) and connector (B) to complete the data cable.
04. Connect connector (C) to port (E) of the inverter and the RJ11 connector (D) to the Gateway data port.
05. When installing the inverter, configure the inverter settings to 3-phase energy meter:
Setting > Feature > Meter/CT > Meter_3p

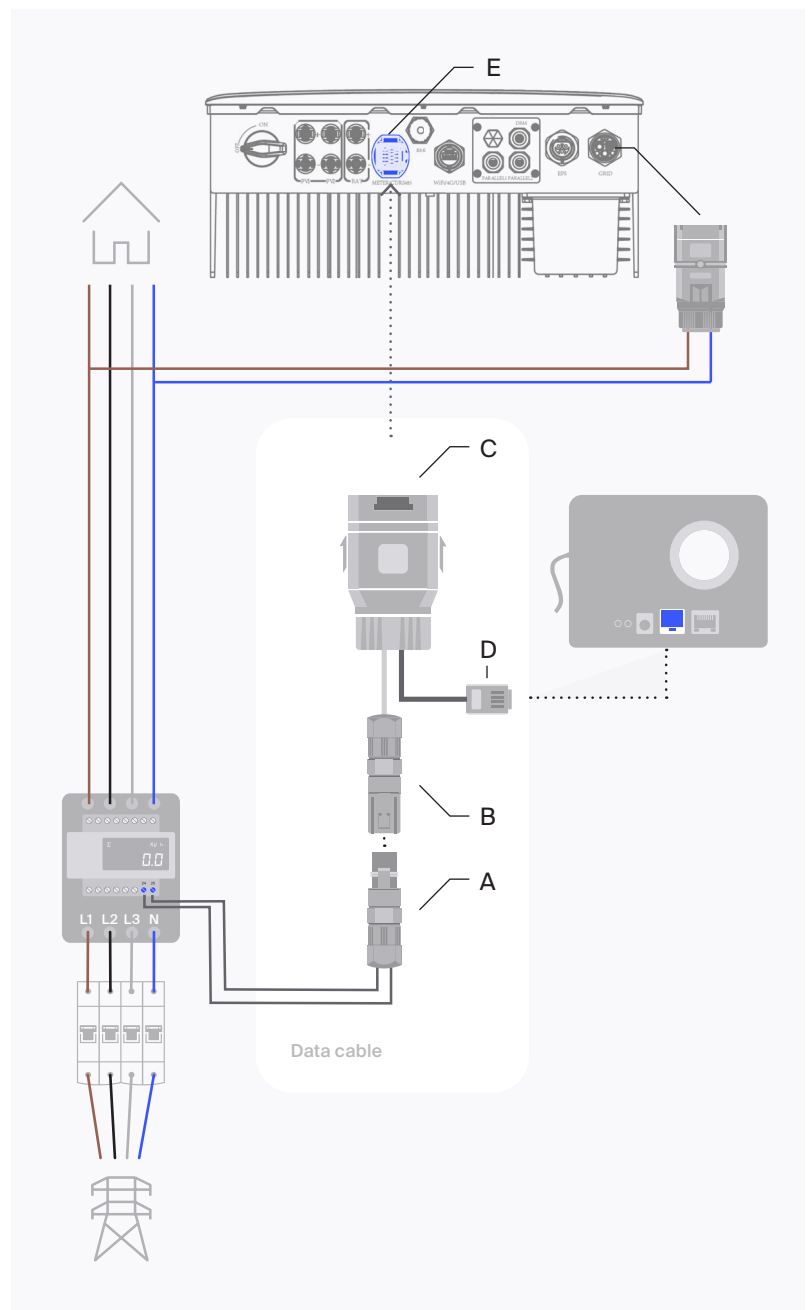

03.4 Fox ESS inverters instructions

Fox ESS H1 / H1-G2 / H1-G2-WL series in a 3-phase system with Delta grid

Necessary items

A. Data cable

Part number:

H1 / H1-G2: TAYLOR-GTW-C-H1-E.

H1-G2-WL: TAYLOR-GTW-C-H1-EWE.

B. Energy meter

Order separately from the Gateway / inverter.

Instructions

01.

Consult the schematic to install a single phase AC system to a smart meter.

02.

Adjust the smart meter settings to Delta grid, do so by following the below sequence

- A) Press "set", change the code to 701
- B) Navigate to CT using the set command
- C) Press the arrow command four times until "net" appears
- D) Set the net setting to n33 and confirm by pressing set again

03.

Connect the energy meter to connector (A):

- Pin 24 on energy meter > pin 1 on connector (A)
- Pin 25 on energy meter > pin 2 on connector (A)

04.

Connect connector (A) and connector (B) to complete the data cable.

05.

Connect connector (C) to port (E) of the inverter and the RJ11 connector (D) to the Gateway data port.

06.

When installing the inverter, configure the inverter settings to 3-phase energy meter:

Setting > Feature > Meter/CT > Meter_3p

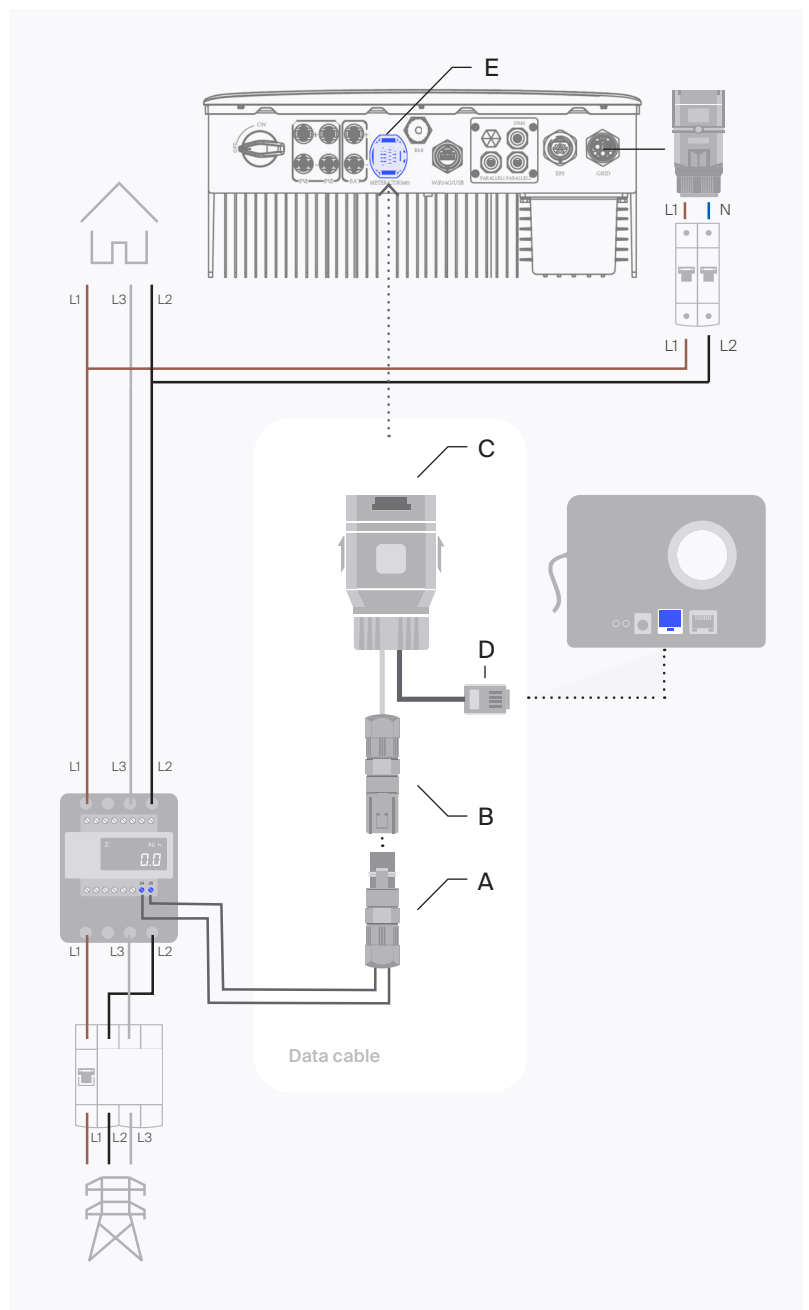

03.4 Fox ESS inverters instructions

Fox ESS H3 series

Necessary items

A. Data cable

Part number: TAYLOR-GTW-C-H3-E.
Order separately from the Gateway.

Instructions

01.

Connect the energy meter to connector (A):

- Pin 24 on energy meter > pin 1 on connector (A)
- Pin 25 on energy meter > pin 2 on connector (A)

02.

Connect connector (A) and connector (B) to complete the data cable.

03.

Connect connector (C) to port (J) of the inverter and the RJ11 connector (D) to the Gateway data port.

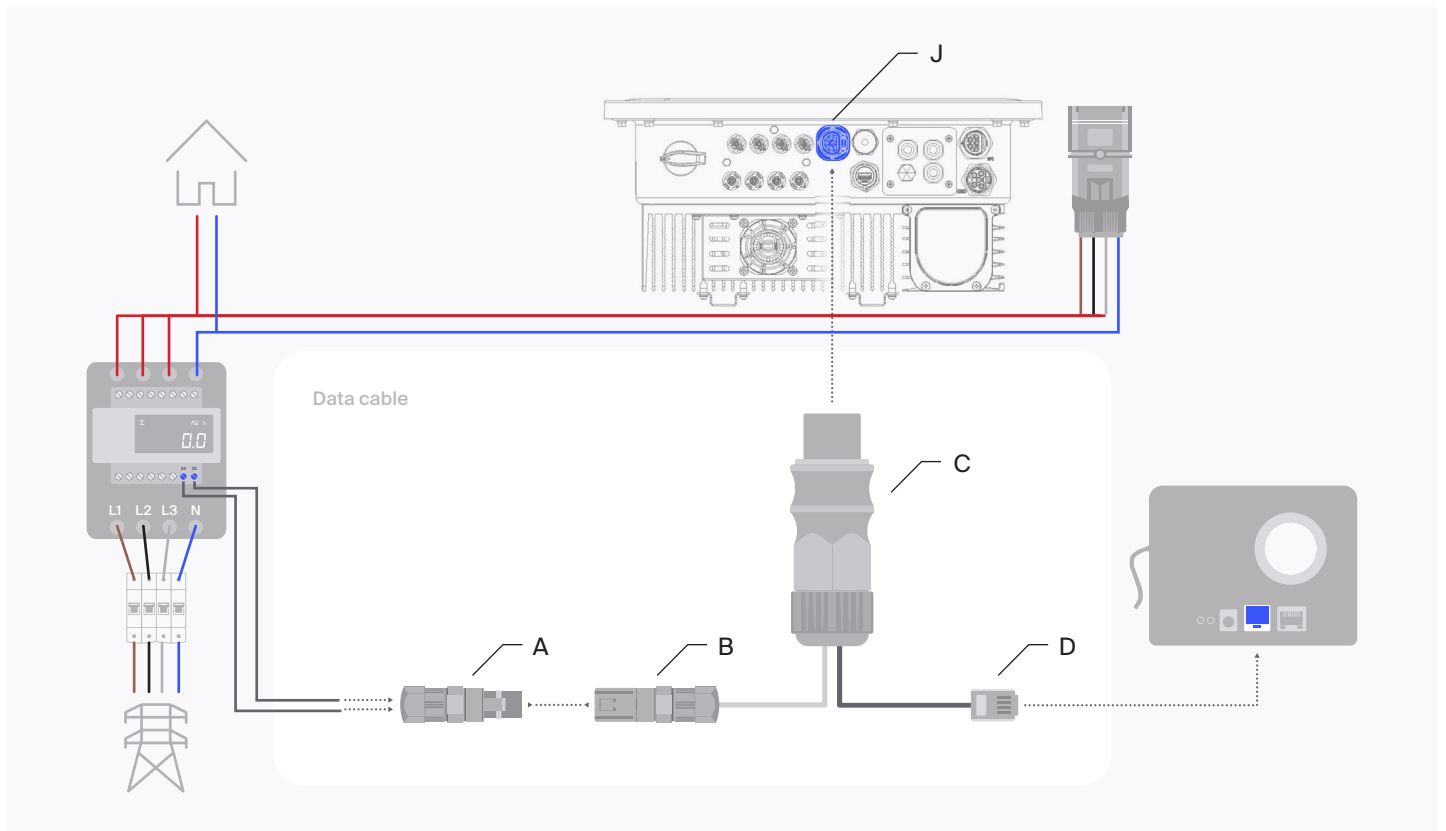

03.4 Fox ESS inverters instructions

Fox ESS H3 Pro / P3 Pro series

Necessary items

A. Data cable

Part number: TAYLOR-GTW-C-H3-EP.
Order separately from the Gateway.

Instructions

01.

Connect the energy meter to connector (A):

- Pin 24 on energy meter > pin 1 on connector (A)
- Pin 25 on energy meter > pin 2 on connector (A)

02.

Connect connector (A) and connector (B) to complete the data cable.

03.

Connect connector (C) to port (K) of the inverter and the RJ11 connector (D) to the Gateway data port.

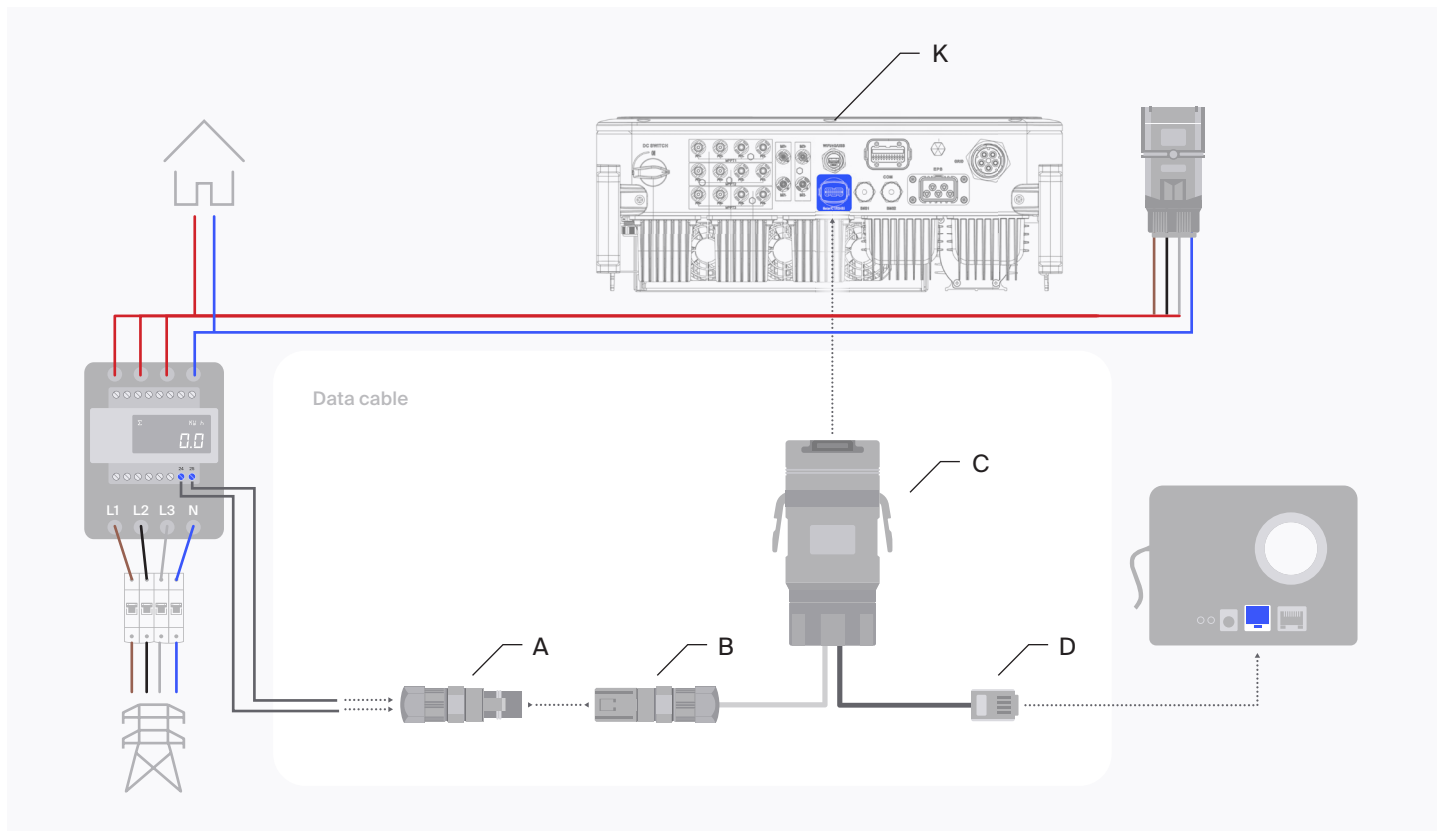

03.4 Fox ESS inverters instructions

Fox ESS P3-S series

Necessary items

A. Data cable

Part number: TAYLOR-GTW-C-H3-ES

Instructions

01.

Connect the energy meter to connector (A):

- Pin 24 on energy meter > pin 1 on connector (A)
- Pin 25 on energy meter > pin 2 on connector (A)

02.

Make sure to not connect any other devices to pin 24 and 25 on the energy meter.

03.

Connect connector (A) and connector (B) to complete the data cable.

04.

Connect connector (C) to port (J) of the inverter and the RJ11 connector (D) to the Gateway data port.

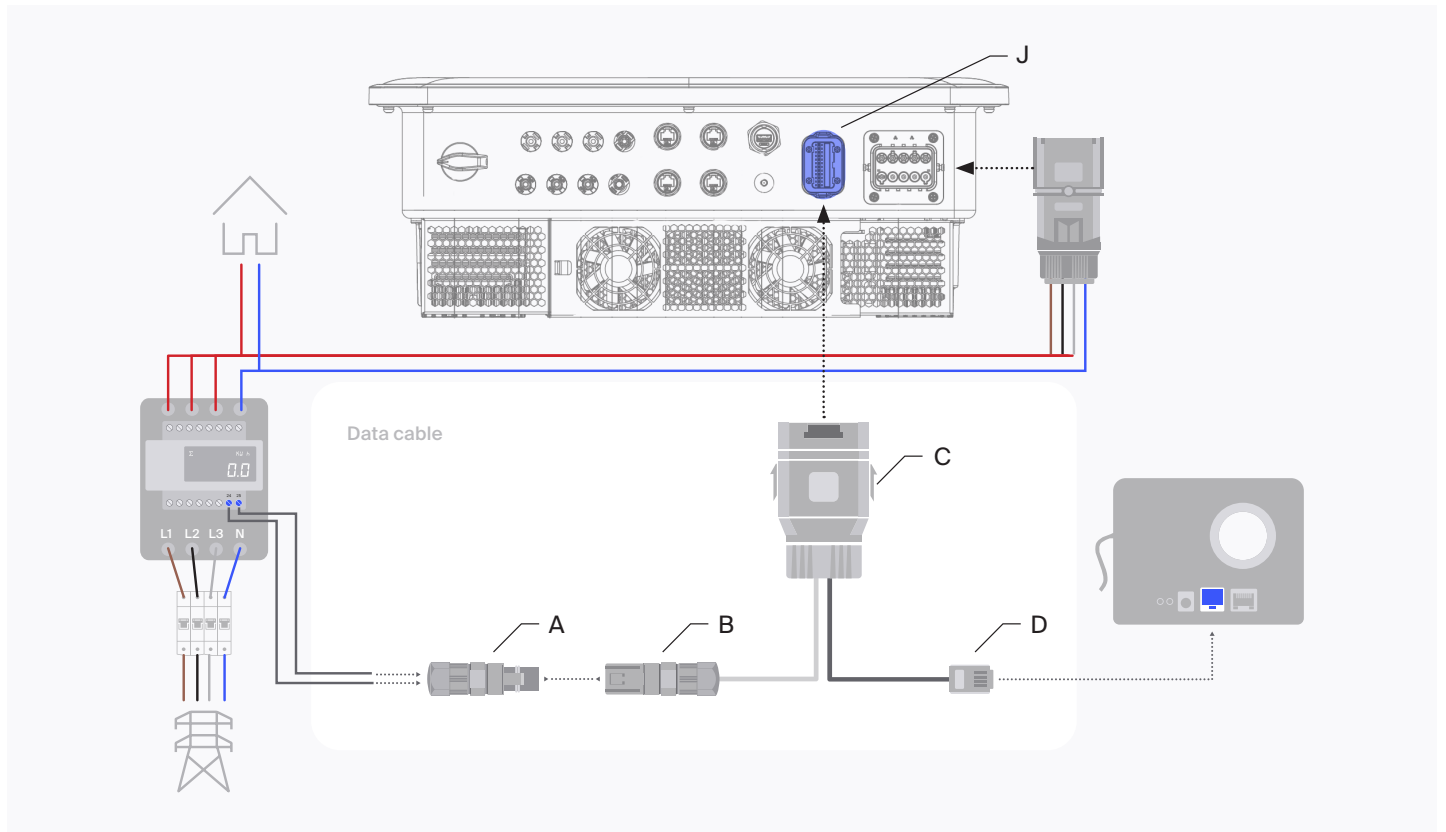

03.4 Fox ESS inverters instructions

Fox ESS S series - G2

Necessary items

A. Data cable

Part number: TAYLOR-GTW-C-F-S-G2.
Order separately from the Gateway.

Instructions

01. Connect the plug to connection (C).



Important Make sure the firmware of the inverter is updated to version 1.24/0.14/A32 or higher. Please contact Taylor support for help with firmware updates.

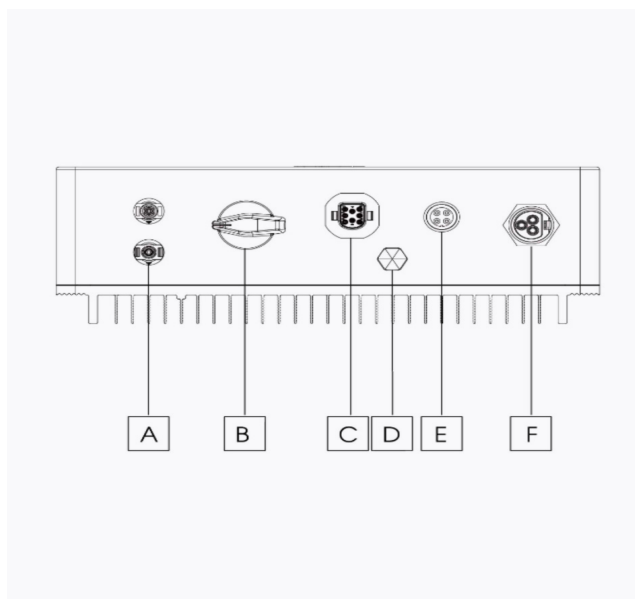

Fox ESS T series - G3

Necessary items

A. Data cable

Part number: TAYLOR-GTW-C-F-T-G3-0.
Order separately from the Gateway.

Instructions

01. Connect the plug to connection (F).



Important Make sure the firmware of the inverter is updated to version 1.19/1.00/1.14 or higher. Please contact Taylor support for help with firmware updates.

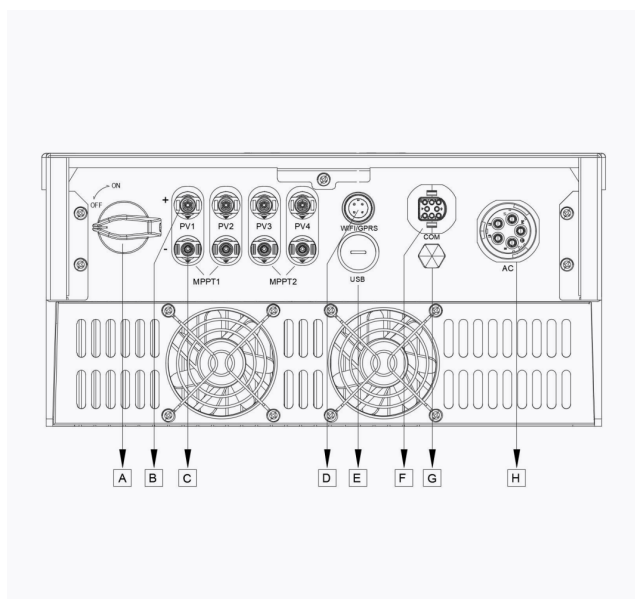

03.5 Goodwe inverters instructions

Goodwe DNS

DNS G3 is not compatible yet

Necessary items

A. Data cable

Part number: TAYLOR-GTW-C-03.
Order separately from the Gateway.

Instructions

01. Demount the RS485 board from the inverter.
02. Pull the cable through the screwcap & RS485 board.
03. Connect it onto the lock - using the table below.

Wire	Wire colour	Connect to pin
	Yellow	Not connected
-	Green	2
+	Red	1
	Black	Not connected

04. Mount the RS485 board back as depicted on the right.

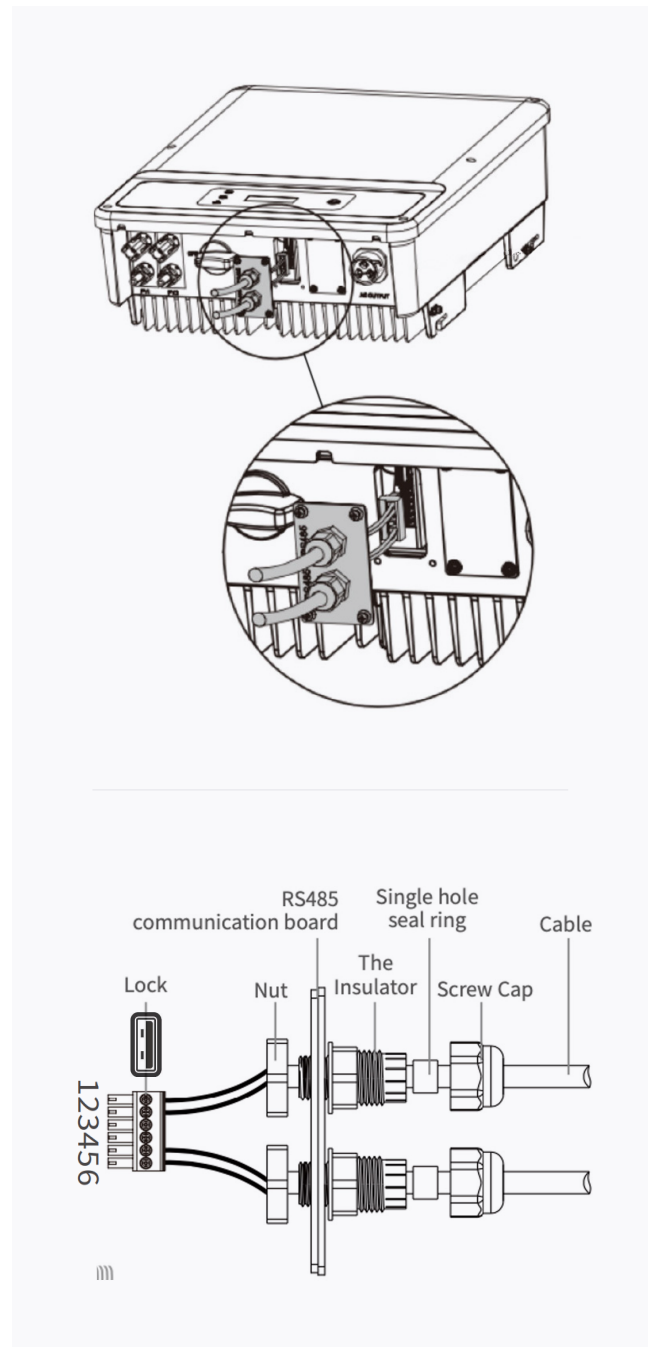

03.5 Goodwe inverters instructions

Goodwe SDT G2 Plus

Necessary items

A. Data cable

Part number: TAYLOR-GTW-C-03.
Order separately from the Gateway.

B. Communication Connector

Delivered with the inverter.

Instructions

01.
Route the taylor data cable through the cable gland (A)

02.
Connect the data cable to part A, refer to the table:

Wire	Wire colour	Connect to pin
	Yellow	Not connected
-	Green	1
+	Red	3
	Black	Not connected

03.
Assemble the connector.

04.
Connect the data cable to the COM port (B).

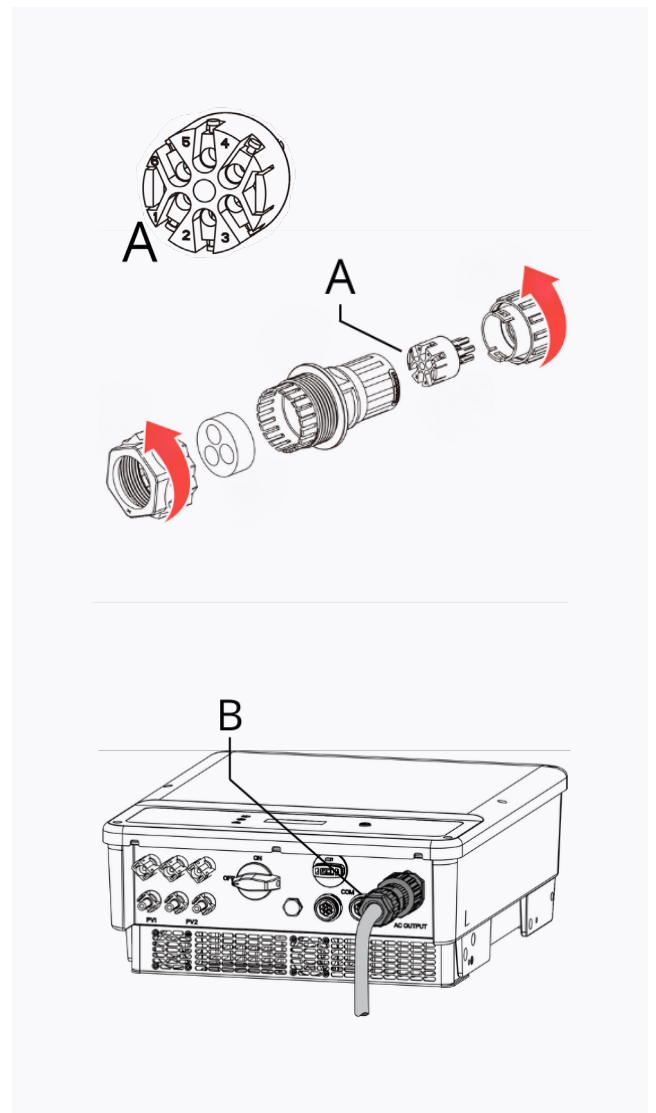

03.5 Goodwe inverters instructions

Goodwe XS

Necessary items

- A. Data cable**
Part number: TAYLOR-GTW-C-03.
Order separately from the Gateway.
- B. RS-485 Connector**
Delivered with the inverter.

Instructions

01. Disassemble the connector (A)(B).
02. Remove the resistor (C).
03. Route the taylor data cable through the cable gland (A)
04. Connect the data cable to part B, refer to the table:

Wire	Wire colour	Connect to pin
	Yellow	Not connected
-	Green	3
+	Red	6
	Black	Not connected

05. Assemble the connector.
06. Connect the plug to connection (A).

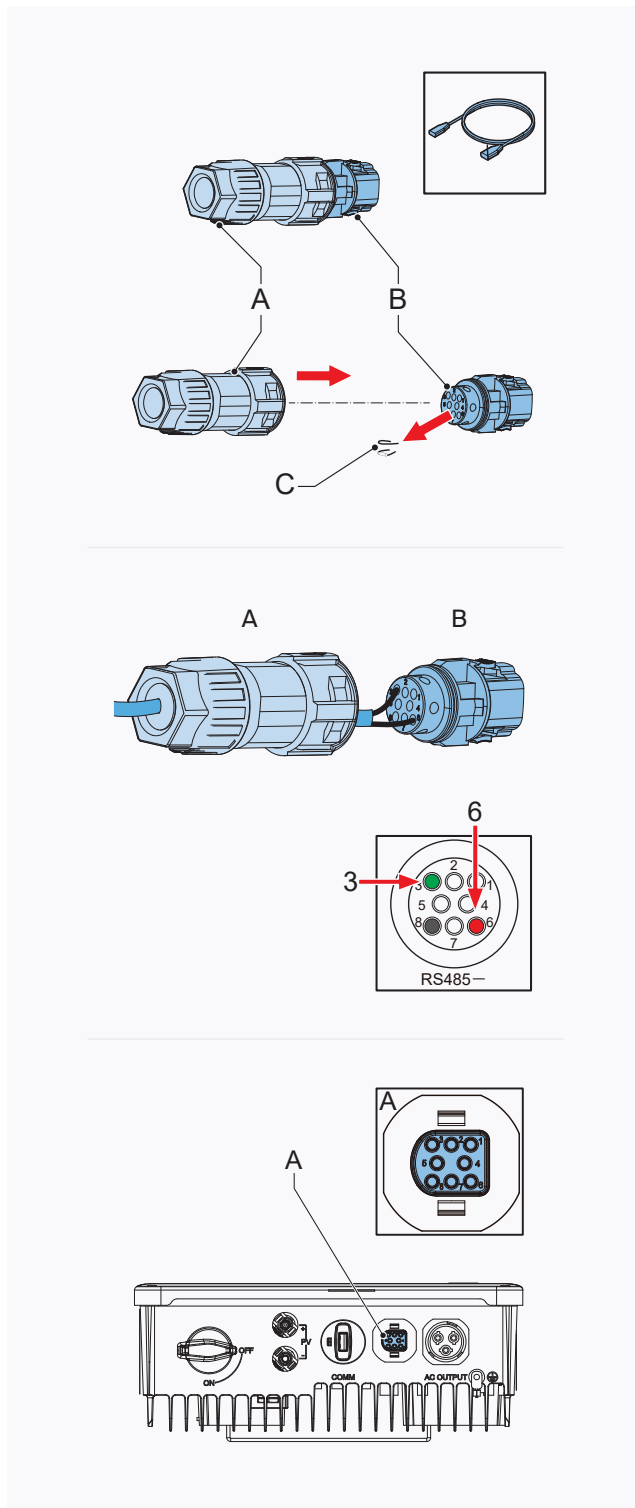

03.6 Solis inverters instructions

Solis

Necessary items

A. Data cable

Part number: TAYLOR-GTW-C-SL-02.
Order separately from the Gateway.

Instructions

01. Connect the plug to connection (A).

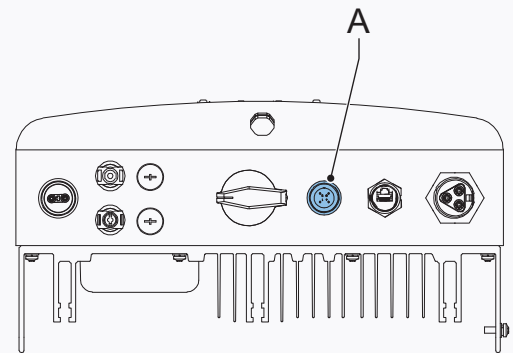

Image for reference. For exact installation instructions, always refer to inverter technical documentation.

Model pictured: Solis Mini S5-GR1P(0.7-3.6)K-M

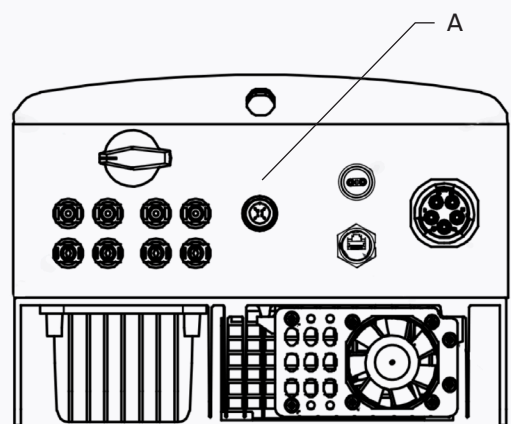

Image for reference. For exact installation instructions, always refer to inverter technical documentation.

Model pictured: Solis 3P(3-20)K-4G

04 List of data cables

name	IPN
Data cable for Taylor (waterproof) Gateway	TAYLOR-GTW-C-WP-03
Data cable for Taylor Gateway	TAYLOR-GTW-C-03
Taylor / Fox ESS data cable for Taylor Gateway - H1 / H1-G2 with CT clamp	TAYLOR-GTW-C-H1-EC
Taylor / Fox ESS data cable for Taylor Gateway - H1-G2-WL with CT clamp	TAYLOR-GTW-C-H1-EW
Taylor / Fox ESS data cable for Taylor Gateway - H1 / H1-G2 with energy meter	TAYLOR-GTW-C-H1-E
Taylor / Fox ESS data cable for Taylor Gateway - H1-G2-WL with energy meter	TAYLOR-GTW-C-H1-EWE
Taylor / Fox ESS data cable for Taylor Gateway - H3	TAYLOR-GTW-C-H3-E
Taylor / Fox ESS data cable for Taylor Gateway - H3 Pro / P3 Pro	TAYLOR-GTW-C-H3-EP
Taylor / Fox ESS data cable for Taylor Gateway - S-G2	TAYLOR-GTW-C-F-S-G2
Taylor / Fox ESS data cable for Taylor Gateway - T-G3-0	TAYLOR-GTW-C-F-T-G3-0
Taylor / Fox ESS data cable for Taylor Gateway - P3-S	TAYLOR-GTW-C-H3-ES
GoodWe data cable for Taylor Gateway - SDT series	TAYLOR-GTW-C-G-00
Solis data cable for Taylor Gateway	TAYLOR-GTW-C-SL-02
<i>Any other inverter</i>	<i>please contact your Taylor sales representative</i>

taylor.

Taylor Technologies B.V.

VAT: NL861599640B01

CoC: 80237193

www.taylor.solar

info@taylor.solar

NL +31 (0)85 888 0605

DE +49 800 0007120

FR +33 801 27 14 55

Torenallee 32-14

5617 BD Eindhoven

The Netherlands

Gateway communication manual

2024-026-R-0004-A9

