

REVISIONS				
ECO	REV.	DESCRIPTION	DATE	APPROVED
10794	A	ADDED TT-TOPS AND PLATFORM ASSMS	06OCT2016	DRK
30401	B	UPDATED PLATFORM ASSYS	19FEB26	JTH
30411	C	FLIPPED FP1/FP2 LABELS	10APR26	JTH

FPSTAIRS

DESCRIPTION
 FPSTAIRS CONSIST OF 2 SEPARATE BUT INTERLACED STAIR STRUCTURES. THEY ARE SHIPPED PRE-ASSEMBLED AND INTERLACED, AND MUST BE MOVED TOGETHER. WHEELS AT THE REAR END OF 2ND STAIR STRUCTURE ARE INTENDED TO AID IN MOVING AND POSITIONING THE STAIRS.

INSTALLATION
 EACH STAIR STRUCTURE IS MOUNTED TO ITS OWN FORCE PLATE. TO COMPLETE FPSTAIRS INSTALLATION POSITION EACH STAIR STRUCTURE SO THAT THE HAND SCREWS ARE OVER THE HOLES IN THE FORCE PLATES AND LIGHTLY TIGHTEN. ALIGN SIDES FACES OF STAIR TREADS AND ADJUST THE POSITION OF THE 2 STRUCTURES SO THAT THE GAPS BETWEEN STAIR RISERS AND ADJACENT STAIR TREADS ARE COMPARABLE. TIGHTEN THE HAND SCREWS.

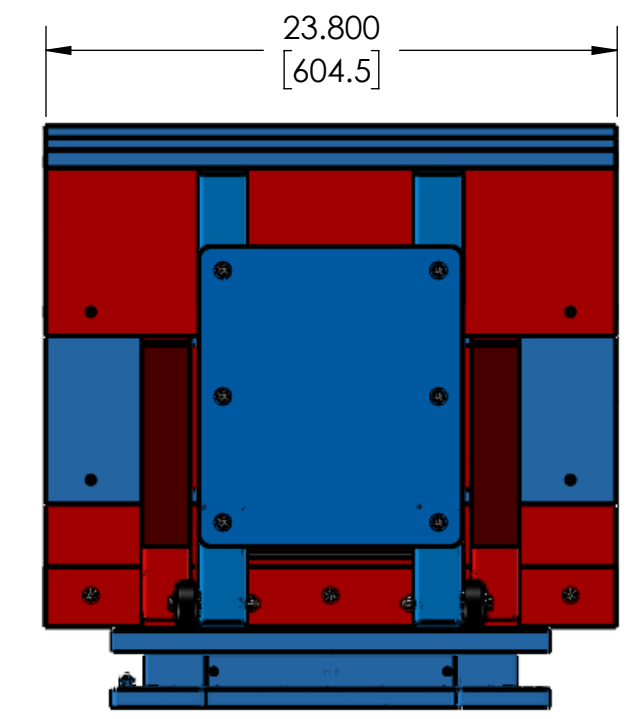
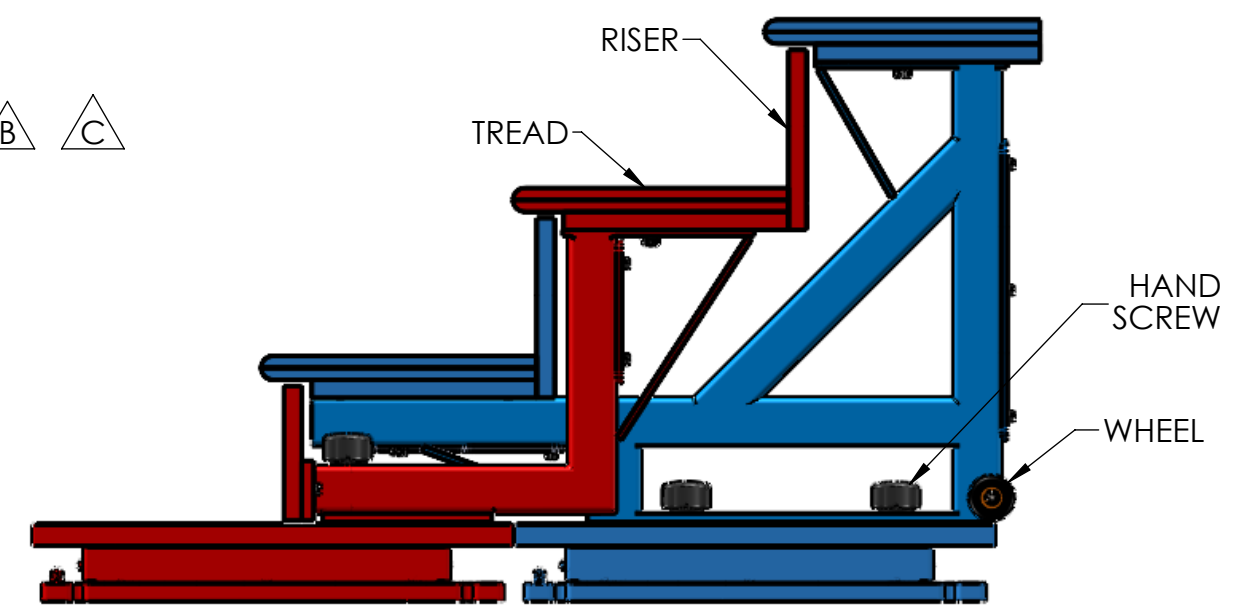
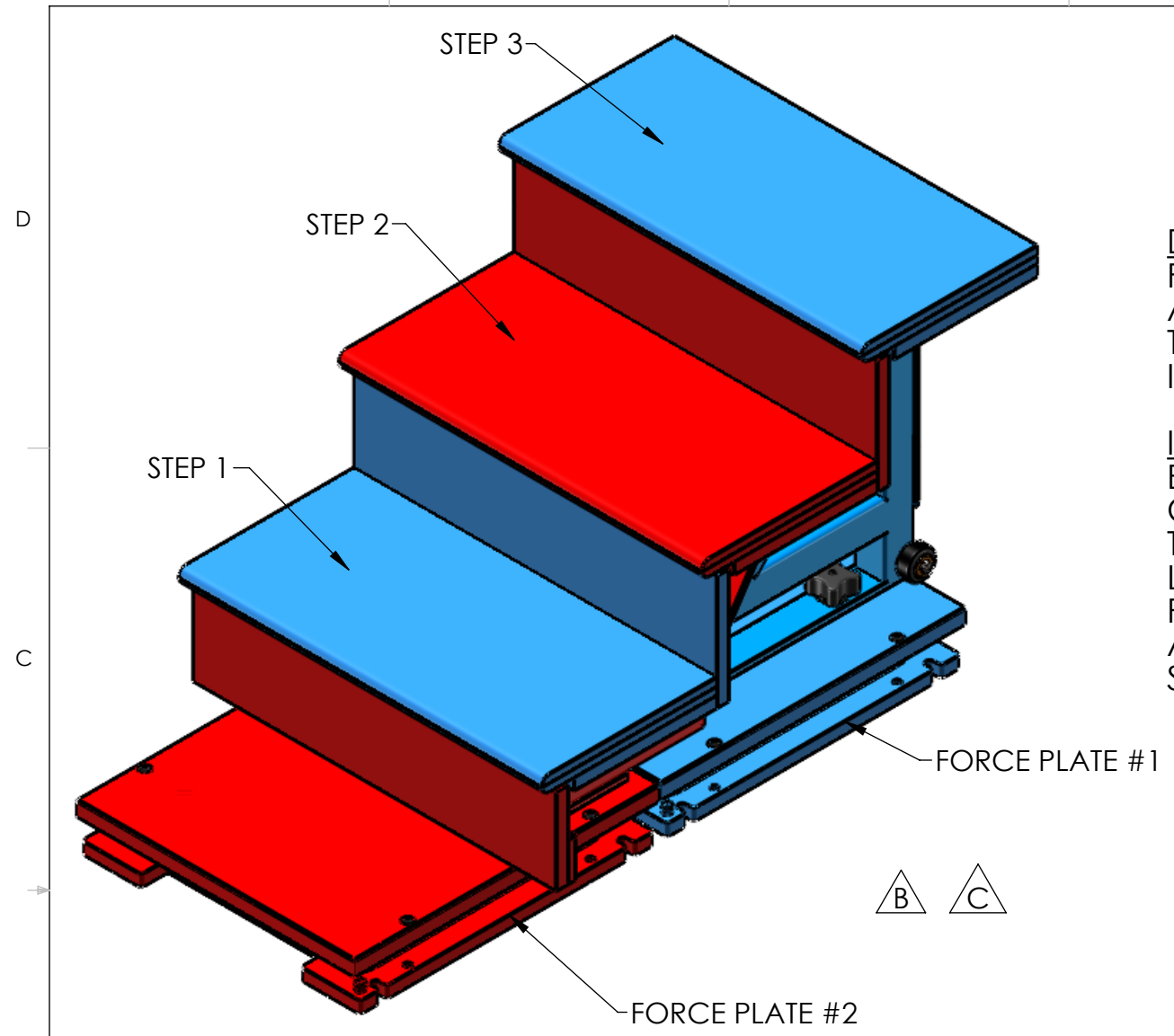

STEP 1 REGISTERS ON FORCE PLATE 1
 STEP 2 REGISTERS ON FORCE PLATE 2
 STEP 3 REGISTERS ON FORCE PLATE 1



PROPRIETARY AND CONFIDENTIAL
 THE INFORMATION CONTAINED IN THIS DRAWING IS THE SOLE PROPERTY OF AMTI. ANY REPRODUCTION IN PART OR AS A WHOLE WITHOUT THE WRITTEN PERMISSION OF AMTI IS PROHIBITED.

UNLESS OTHERWISE SPECIFIED: DIMENSIONS ARE IN INCHES TOLERANCES: DECIMALS .X ± .030 .XX ± .015 .XXX ± .005 FRACTIONAL ± 1/32		NAME CLH	DATE 9/27/13	
INTERPRET GEOMETRIC TOLERANCING PER: ANSI Y14.5 2009		ENG APPR. CLH	10/02/13	
MATERIAL: --		PURCHASING:		OR6 ASSEMBLY
FINISH: --		COMMENTS: Update MRP		SIZE B DWG. NO. 24N-34962 REV C
DO NOT SCALE DRAWING				SCALE: 3:1 WEIGHT: SHEET 1 OF 2

PRINTED COPIES ARE NOT CONTROLLED UNLESS MARKED: INITIALS _____

REVISIONS				
ECO	REV.	DESCRIPTION	DATE	APPROVED
--	A	SEE PAGE 1	--	--

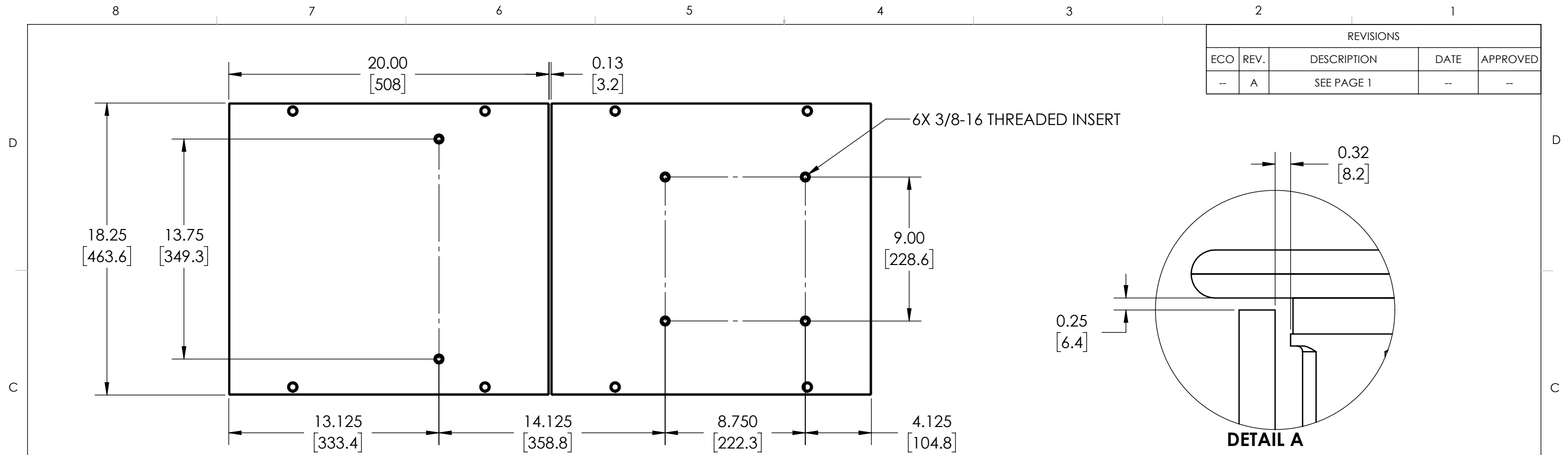

**TOP OF PLATES
(STAIRS REMOVED)**

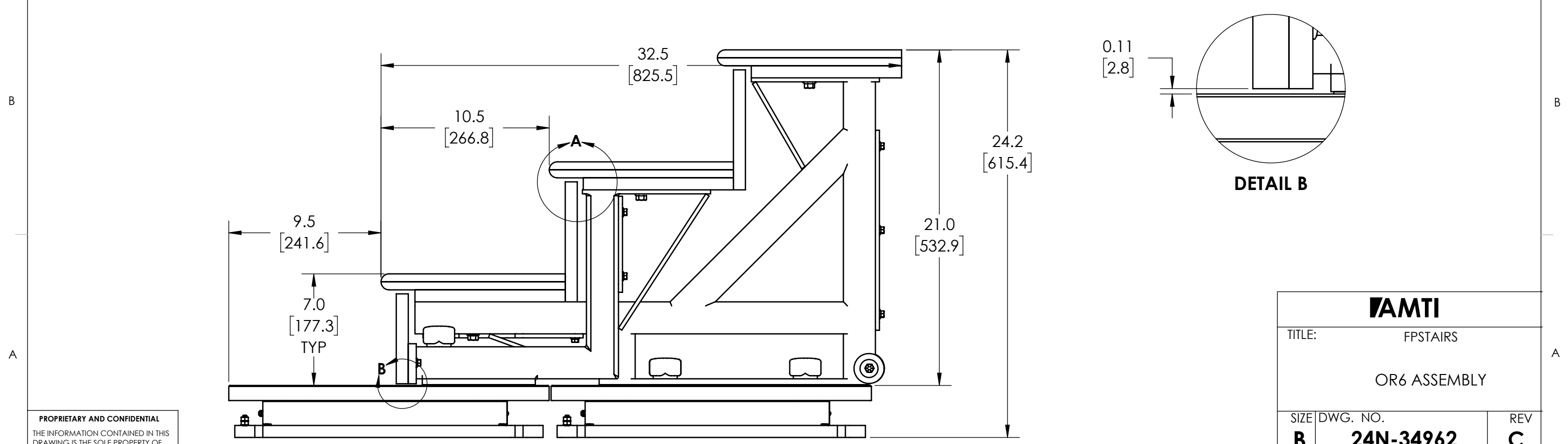

PROPRIETARY AND CONFIDENTIAL
 THE INFORMATION CONTAINED IN THIS DRAWING IS THE SOLE PROPERTY OF AMTI. ANY REPRODUCTION IN PART OR AS A WHOLE WITHOUT THE WRITTEN PERMISSION OF AMTI IS PROHIBITED.

AMTI		
TITLE: FPSTAIRS		
OR6 ASSEMBLY		
SIZE: B	DWG. NO.: 24N-34962	REV: C
SCALE: 3:1 & WEIGHT:		SHEET 2 OF 2

PRINTED COPIES ARE NOT CONTROLLED UNLESS MARKED: INITIALS _____