



SPEED QUEEN® ON-PREMISES LAUNDRY SOLUTIONS

Hardmount Washer-Extractors

SA332

SA520

Features and Benefits

- Rigid mounted, normal spin
- Stainless steel panels
- Stainless steel drum and tSB
- QED Select – fully programmable microprocessor
- Patented soap hopper
- High capacity water inlets
- Large drain valves (2 x Ø 76 mm)
- Easy access to all vital parts from the front
- Large door opening for easy loading & unloading

Options

- USB plug (on the back panel)
- Liquid soap connection
- Steam heating version

- Liquid soap pumps
- Water recovery kit
- 3rd water inlet
- ECO version : lower kW rating on request

Controls

- QED – fully programmable control with 20 Pre-set programs and memory up to 99.
- Quantum Basic – Programmable control with 6 programs (+2 cycle modifiers and Imbalance detection)



Hardmount Washer-Extractors

| | | SA332 | SA520 |
|------------------------------|------------|----------------|----------------|
| INNERDRUM | | | |
| Capacity 1:09 | kg (lb) | 37(82) | 58(128) |
| Capacity 1:10 | kg (lb) | 33(73) | 52(115) |
| Volume | litres | 332 | 520 |
| Diameter | mm | 914 | 914 |
| DRUM SPEED | | | |
| Wash | rpm | 38 | 38 |
| Extraction | rpm | 540 | 440 |
| G-FACTOR | | 150 | 100 |
| HEATING | | | |
| Electricity | kW | 27 | 40,6 |
| Steam | bar | 1 - 8 | 1 - 8 |
| Hot water | °C | 90 | 90 |
| Sound pressure level | dB (A) | < 65 | < 65 |
| Water valves connection | BSP | 3/4" | 1" |
| Water pressure | kPa | 100-800 | 100-800 |
| Rec. water pressure | kPa | 300-500 | 300-500 |
| Water inlet | l/min | 66-188 | 183-518 |
| Drain valve | outer Ø mm | 2x76 | 2x76 |
| Flow amount with drain valve | l/min | 2x210 | 2x210 |
| Steam valve connection | BSP | 3/4" | 3/4" |
| Steam pressure | kPa | 100-800 | 100-800 |
| DIMENSIONS | | | |
| Size H×W×D | mm | 1500×1060×1030 | 1500×1060×1315 |
| Net weight | kg | 410 | 520 |
| TRANSPORT DATA | | | |
| Packed H×W×D | mm | 1625×1088×1060 | 1625×1088×1345 |
| Gross weight | kg | 425 | 535 |

* 200 G-factor execution

| | A | B | C | D | E | F | G | H | I | J | K | L | M | N | O | P | Q | S | T |
|-------|-------|-------|--------|------|-----|-----|-----|------|------|-----|-----|-----|-----|------|------|-----|----|-----|-----|
| SA332 | 1060 | 1030 | 1500 | 936 | 465 | 318 | 120 | 1326 | 1366 | 113 | 248 | 383 | 671 | 1349 | 1413 | 528 | 66 | 145 | 482 |
| SA520 | 1060 | 1315 | 1500 | 1221 | 465 | 318 | 120 | 1414 | 1374 | 88 | 223 | 363 | 671 | 1349 | 1332 | 528 | 66 | 145 | 482 |
| | width | depth | height | | | | | | | | | | | | | | | | |

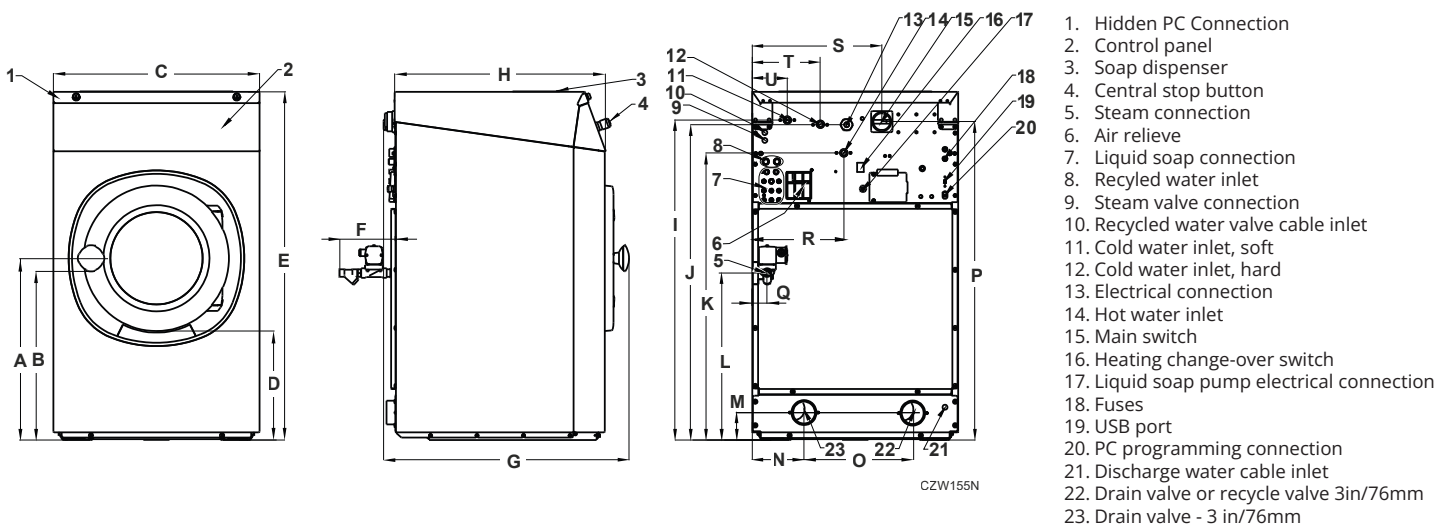

1. Hidden PC Connection
2. Control panel
3. Soap dispenser
4. Central stop button
5. Steam connection
6. Air relieve
7. Liquid soap connection
8. Recycled water inlet
9. Steam valve connection
10. Recycled water valve cable inlet
11. Cold water inlet, soft
12. Cold water inlet, hard
13. Electrical connection
14. Hot water inlet
15. Main switch
16. Heating change-over switch
17. Liquid soap pump electrical connection
18. Fuses
19. USB port
20. PC programming connection
21. Discharge water cable inlet
22. Drain valve or recycle valve 3in/76mm
23. Drain valve - 3 in/76mm