

World leaders in dehumidification.

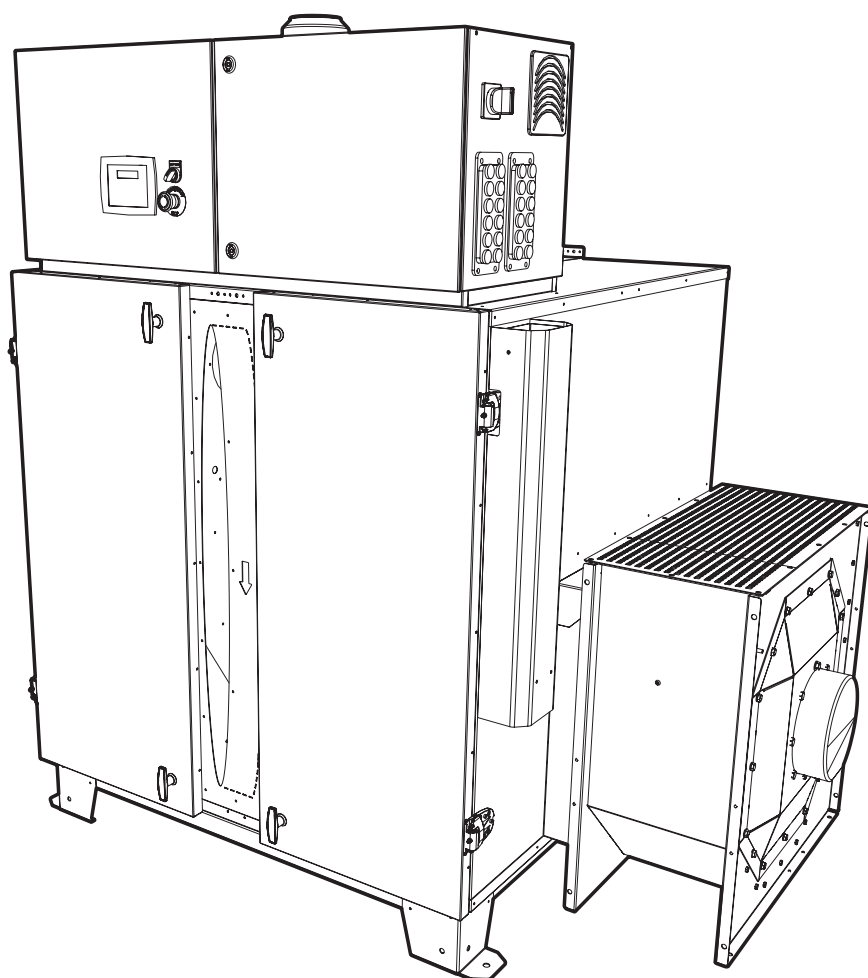

# USER'S MANUAL

Document version: EN.072 24.04  
Product: RLZ-81/82/101/102/102L/104



**CE** Desiccant dehumidifier

*Product supplied may differ from that illustrated*

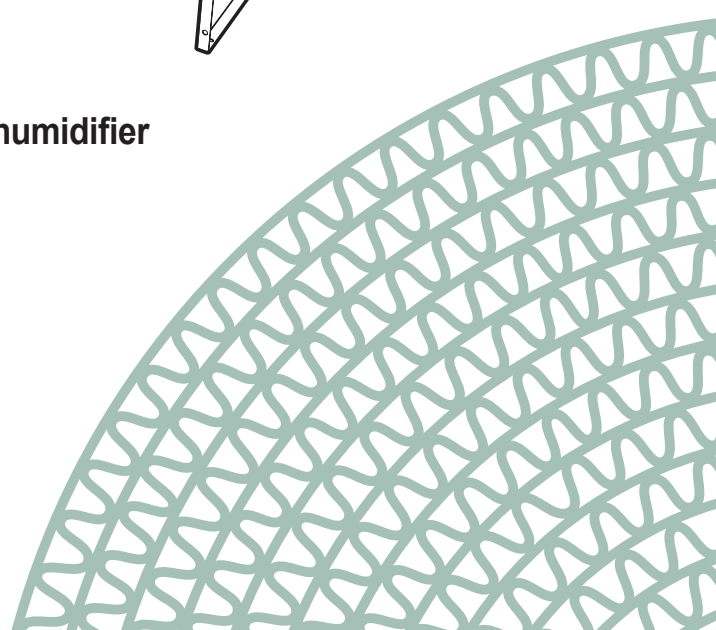

*Empty page*

# Contents

<b>1. Safety</b> .....	<b>7</b>	6.9 heater power output setting .....	17
1.1 Aim of this document .....	7	6.10 Information .....	17
1.2 Emphasised text.....	7	6.11 Reset the PLC.....	17
1.3 Intended use.....	7	6.12 PLC operation messages.....	18
1.3.1 Hazardous operating conditions .....	7	6.13 Reset buttons & switches .....	18
1.3.2 Responsibilities of the operator .....	7	<b>7. Functions</b> .....	<b>19</b>
1.3.3 Minimising hazards .....	7	7.1 Dehumidification function.....	19
1.4 Safety .....	7	7.1.1 Automatic or Manual .....	19
1.5 Inspection of goods .....	7	7.1.2 Automatic mode - Airflow .....	19
1.6 Safety advice regarding transportation.....	7	7.1.3 Humidistat connection .....	19
1.7 Installation .....	7	7.1.4 0-10VDC connection.....	19
1.8 Electrical installation.....	8	7.2 Remote control switch .....	20
1.9 Commissioning .....	8	7.3 Temperature safety devices .....	20
1.10 Operation .....	8	7.4 Pressure nozzles.....	20
1.11 Maintenance.....	8	7.5 Regeneration airflow guard .....	20
1.12 Disposal/recycling.....	8	7.6 Frequency converter to fans .....	20
<b>2. Introduction</b> .....	<b>9</b>	<b>8. Option &amp; accessory</b> .....	<b>21</b>
2.1 Type plate overview .....	9	8.1 Frost protection device .....	21
2.2 Model designation .....	9	8.2 Filter guard .....	21
2.3 Serial number structure .....	9	8.3 Rotation guard.....	21
2.4 Other unit information .....	9	8.4 Adjustable rotor speed.....	21
<b>3. Product description</b> .....	<b>10</b>	8.5 Insulation.....	21
3.1 Product overview.....	10	8.6 Reactivation heater coils .....	21
3.2 Applications.....	10	8.7 ICE-fan .....	21
3.3 Principle of operation .....	10	8.8 Energy saving.....	22
<b>4. Installation</b> .....	<b>11</b>	8.9 humidity controller .....	22
4.1 Unit installation .....	11	<b>9. Troubleshooting</b> .....	<b>23</b>
4.1.1 Fork lifting.....	11	9.1 Error codes .....	23
4.1.2 Transport.....	11	9.2 General troubleshooting.....	24
4.1.3 Positioning .....	11	9.3 Capacity troubleshooting .....	24
4.2 Securing the unit.....	12	<b>10. Maintenance</b> .....	<b>25</b>
4.3 General Duct work installation .....	12	10.1 Regular service interval .....	25
4.4 Damper installation .....	12	10.2 Washing the rotor .....	25
4.5 Pipe work connections .....	13	<b>11. Technical data</b> .....	<b>26</b>
4.5.1 Steam installation and scope of supply.....	13		
4.6 Liquid medium coil installation .....	13		
4.7 Humidistat/electronic controller installation .....	14		
4.8 Electrical connection .....	14		
4.8.1 Power supply.....	14		
4.8.2 Earth leakage circuit breaker .....	14		
4.8.3 Humidistat connections.....	14		
4.8.4 0-10VDC signal .....	14		
4.8.5 Remote control.....	14		
4.8.6 Potential-free signals .....	14		
<b>5. Operation check &amp; adjustment</b> .....	<b>15</b>		
5.1 Pre-operation check .....	15		
5.2 Start-up test and adjustment.....	15		
<b>6. Operating</b> .....	<b>16</b>		
6.1 Keys .....	16		
6.2 Start.....	16		
6.3 Stop.....	16		
6.4 Energy consumption - Heaters .....	16		
6.5 Run time - Process fan.....	16		
6.6 Check temperature.....	16		
6.7 Settings .....	17		
6.8 Process airflow setting.....	17		

*Empty page*

## Appendix

1. Component list
2. Dimension
3. Frequency converter quick guide
4. Parameter list
5. Harmful chemicals and solvents for rotors
6. CE-declaration

Electrical wiring diagram is stored in the document pocket, depending on the unit, inside or outside the electrical box. The electric diagram has a drawing number. This number should correspond to the sticker with a drawing number found inside the electric cabinet.

If applicable, separate users' manuals for components with separate controls are found in the document pocket.

## Figures

FIGURE 1: Type plate.....	9
FIGURE 2: Model name .....	9
FIGURE 3: Serial number structure.....	9
FIGURE 4: Product overview .....	10
FIGURE 5: Principle of operation & rotor .....	10
FIGURE 6: Forks in contact with both sides of the frame.....	11
FIGURE 7: Units with handles .....	11
FIGURE 8: Exercise caution when lifting and transport a unit .....	11
FIGURE 9: Transportation bracket.....	12
FIGURE 10: Installation of wet air out duct.....	12
FIGURE 11: Steam coil and pipe installation .....	13
FIGURE 12: Hot and cold water coil.....	13
FIGURE 13: Humidistat positioning.....	14
FIGURE 14: PLC-keys .....	16
FIGURE 15: PLC operation messages .....	18
FIGURE 16: Illustration of automatic and manual functions.....	19
FIGURE 17: Electronic filter guard .....	21
FIGURE 18: Manometer - mechanical filter guard.....	21
FIGURE 19: Manometer - mekanisk filtervakt (Magnehelic) .....	21
FIGURE 20: Binary control .....	22
FIGURE 21: Linearly control.....	22
FIGURE 22: EH3 T2.....	22
FIGURE 23: EH4.....	22
FIGURE 24: Troubleshooting table and solution .....	23
FIGURE 25: General troubleshooting table and solution .....	24
FIGURE 26: Capacity troubleshooting and solution table.....	24
FIGURE 27: Service chart .....	25

*Empty page*

# 1 SAFETY

## 1.1 AIM OF THIS DOCUMENT

This document accompanies delivery and is therefore an integral part of the equipment. It describes the machine's design and configuration at the time of delivery.

In the interest of safety, please study this document before installing or operating the equipment.

Instructions relating to safety, handling, operation and maintenance must be followed.

Non-compliance can result in serious personal injury or damage to the machinery and may invalidate manufacturers' liabilities and warranties.

This document includes guidance for:

- Installers
- Operators
- Maintenance staff

Please retain this document throughout the lifetime of the equipment.

## 1.2 EMPHASISED TEXT



**Caution!** Indicates hazards that could result in damage to the equipment.



**Warning!** Indicates "potentially" hazardous situations that could result in damage to the equipment, serious personal injury or death.



**Danger!** Indicates "imminently" hazardous situations that could result in damage to the equipment, serious personal injury or death.



**Attention!** Indicates important information or instructions that require special attention.

## 1.3 INTENDED USE

This equipment is specifically designed for atmospheric air drying. It is unsuitable for any other use. For further advice please contact a DST representative.

Unless specifically stated in this manual, the following applications are prohibited:

- conditioning of gases (other than air)
- conditioning of air contaminated with chemicals or aggressive elements
- conditioning of air containing flammable or explosive elements
- in rooms or air systems having a potentially explosive atmosphere (ATEX)
- conditioning of air at elevated pressures
- air entering the rotor that has not been properly filtered with at least G4 class
- compounds in the air that will possibly deteriorate the silica gel rotor - see appendix for detailed information

### 1.3.1 HAZARDOUS OPERATING CONDITIONS

Operation of the system is deemed to be hazardous if it is:

- not operated inside or is not protected within a weatherproof enclosure.
- not operated within the permitted operating parameters (see technical specifications)
- operated outside the scope of 'normal' use (see intended use)

### 1.3.2 RESPONSIBILITIES OF THE OPERATOR

It is the responsibility of the operator of the system to ensure that all personnel engaged in the installation, operation, maintenance and service of the equipment have read and understood the relevant sections of this manual.

For your own safety, wear the appropriate personal protective equipment (PPE).

### 1.3.3 MINIMISING HAZARDS

To ensure that risk to personnel is minimised:

- Ensure that all activities relating to this equipment are carried out by qualified and authorised staff only.
- Identify and prevent potential safety hazards in the environment.

To ensure a failure-free operation:

- Keep this manual ready to hand with the unit.
- Use the machine as intended only.
- Only use the machine if it is fully functional.
- Check the condition of the machine before using.
- Check the machine for operational efficiency at regular intervals.
- Carry out maintenance and testing at prescribed intervals.

## 1.4 SAFETY

This equipment conforms to the relevant European regulations and directives and is designed and manufactured to be safe and reliable in operation.

The continued safety and reliability of the supplied equipment is entirely dependent on its correct handling, installation, operation and maintenance.

## 1.5 INSPECTION OF GOODS

Check for transportation damage! Use this product only if you assess it as being undamaged and faultless. Any damage must be recorded by the forwarder at the time of delivery and reported to the supplier of the equipment at the earliest opportunity.

Please check the equipment carefully for damage upon receipt and after removal of all packaging.

## 1.6 SAFETY ADVICE REGARDING TRANSPORTATION



**Warning!** Only use tested and certified lifting equipment to offload and position the unit.



**Warning!** If a forklift is used to move the unit, please ensure the load is evenly balanced.



**Warning!** If lifting the unit or cassette on a pallet, ensure the unit is firmly secured to the pallet.



**Warning!** Evacuate and secure the danger area during lifting and positioning of the unit.

## 1.7 INSTALLATION



**Attention!** Installation, testing, commissioning and maintenance must be carried out by a qualified person or under the supervision of a qualified person. Wherever possible, all mechanical work must be carried out with the electrical supply switched off.

A qualified person (mechanical) is defined in this manual as:



- a mechanical technician or engineer qualified to service and maintain air conditioning plant and associated systems who
- has completed the appropriate health and safety training
- has read and is familiar with the contents of this manual
- is professionally competent to commission and service this type of equipment.



**Caution!** The air dryer is designed for internal installation. For external use it will require a weatherproof enclosure.



**Caution!** The air dryer must be installed on a horizontal plane.

-  **Attention!** The air ducts must be vibration-free and sizable enough to prevent pressure build-up when conveying the incoming and outgoing air from the unit.
-  **Attention!** The incoming and outgoing outlets on the machine are not designed to bear any weight from the air ducts system.
-  **Attention!** The wet air outlet duct must be insulated to prevent condensate and ice build-up in cold conditions.

## 1.8 ELECTRICAL INSTALLATION

-  **Attention!** Wherever possible, all electrical work must be carried out with the electric supply switched off. It is recommended that electrical isolators be locked in the off position. All electrical work must be carried out by a qualified person or under the supervision of a qualified person.

A qualified person (electrician) is defined in this manual as:

- an electrical technician or engineer qualified to service and maintain air conditioning plants
- has completed the appropriate health and safety training
- has read and is familiar with the contents of this manual.

-  **Danger!** If the unit control panel isolation switch is off, the incoming cable terminals may still be live!

-  **Danger!** If working on the unit's isolation switch, ensure that the electrical power is isolated and locked to prevent accidental resetting.

-  **Danger!** Electrical connections are to be made in accordance with local regulations.

-  **Attention!** Check that the incoming electrical supply conforms to the electrical wiring diagram and the manufacturer's type plate attached to the unit.

-  **Caution!** Loose terminal connections! Due to vibration during transportation it is advised that electrical terminals be checked for security and retightened where necessary. The following connecting terminals in the electrical control cabinet should be checked periodically and retightened if necessary:

- connecting terminals in the main isolator switch
- connecting terminals in main components of the heater circuits
- connecting terminals in main components of the fan circuits

Periodically as defined in this manual means:

- during installation
- during maintenance

-  **Caution!** Parameters used in the electrical protection and alarm circuits must not be modified or adjusted. Factory (default) parameters are shown in the electrical wiring diagrams, technical data or parameter list.

-  **Warning!** This equipment will contain high voltage electrical components!

## 1.9 COMMISSIONING

-  **Attention!** Equipment fans can produce noise levels above 80 dB (A). Use ear protection if someone are near an operating machine for any length of time.

### 1.10 OPERATION

-  **Caution!** Use the normal shut-down procedure in the operating chapter. If switching the unit off in an EMERGENCY, the main isolator switch or emergency stop button may be used. However, residual heat from the heater elements will remain in the unit and this can result in damage to components close to the heater.

-  **Caution!** On no account should the unit be operated without air filters installed!

-  **Caution!** Do not expose the unit to an ambient temperature that exceeds 50 °C/122 °F (e.g inside a plant room) for a long period of time. This may damage the internal components!

-  **Caution!** Do not process air at a temperature higher than 40°C/104°F. This may damage the internal components!

## 1.11 MAINTENANCE

-  **Caution!** Defective electrical components and defective wiring must be replaced immediately. The equipment must not be operated until the defect has been repaired and the unit has been retested.

-  **Caution!** For maintenance purposes, use the normal shut-down procedure as described in the operating chapter and allow the system to cool down before attempting to access internal components.

-  **Danger!** To prevent unintentional restart, ensure that the main isolator switch is off and the power is isolated before servicing internal components.

-  **Attention!** Advise all operating and maintenance personnel of the automatic restart function if applicable.

-  **Attention!** Pay attention to accessibility requirements for maintenance and service purposes.

-  **Danger!** Only certified personnel are allowed to adjust, repair or modify the unit's refrigerant system. Contact a DST representative for any questions (Econosorb & Frigosorb only).

-  **Caution!** The operation of all electrical safety devices is to be checked at commissioning and during service/maintenance. Under no circumstances are these devices to be deactivated (e.g., during adjustment or bridging).

-  **Caution!** Do not expose the unit to water jets during the washing-down procedure!

-  **Caution!** Do not wash the rotor!

-  **Warning!** Allow the fans to come to a complete stop and the unit to be isolated from the electrical supply before removing any panels!

-  **Warning!** The unit is equipped with a heating element. Do not touch the equipment whilst it is hot. Allow the unit to cool for at least **30 minutes** before any service or maintenance is performed.

-  **Danger!** Manually isolate the unit from the electrical supply by turning the main isolator to "OFF" and secure it with a lock pad before conducting any type of service and maintenance work on the unit

## 1.12 DISPOSAL/RECYCLING

When the unit is no longer in use, dismantle the unit and recycle the components according to local regulations. Contact a DST representative if you have any questions.

## 2 INTRODUCTION

### 2.1 TYPE PLATE OVERVIEW

The manufactured unit is identified by a type plate. The details on the type plate are set out as follows:

1. Model designation
2. Serial number
3. Electrical supply information
4. Regeneration heater power

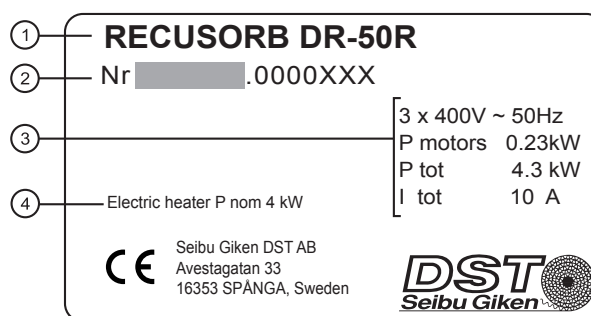

FIGURE 1: Type plate

### 2.2 MODEL DESIGNATION

The model designation is the name of the model and what type of regeneration the unit is fitted with.

1. Principle type
2. Model name
3. Regeneration heater type - the type of heater the unit is equipped with.\*

<b>R</b> = Resistive (electric)	<b>HW</b> = Hot water
<b>G</b> = Gas	<b>WW</b> = Warm water
<b>S</b> = Steam	<b>D</b> = Diesel
	<b>O</b> = Oil

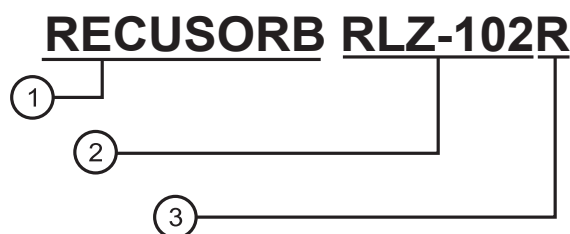

FIGURE 2: Model name

\*Not applicable for single-phase unit.

### 2.3 SERIAL NUMBER STRUCTURE

The serial number is composed of different codes to identify the unit type. Units manufactured pre 2006 have a modified serial number structure which does not match the current structure.

1. Unit (e.g. RLZ-102)
2. Special unit (**aa**) - code to indicate a special manufactured unit  
SP = Special  
**Note:** The absence of SP indicates a standard manufactured unit; e.g. RLZ-102SP is a special manufactured unit, and RLZ-102 is a standard manufactured unit.
3. Serial number (**bbbbbbb**) - serial number of the manufactured unit  
001, 002, 003, 004... n

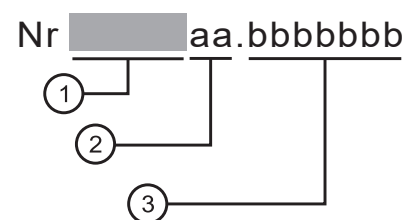

FIGURE 3: Serial number structure

### 2.4 OTHER UNIT INFORMATION

In the appendix, a component list details spare parts with articlenumbers as well as the electrical diagram number for the electrical box. If there is a special unit with custom-installed components that list will include a list of installed options.

# 3 PRODUCT DESCRIPTION

## 3.1 PRODUCT OVERVIEW

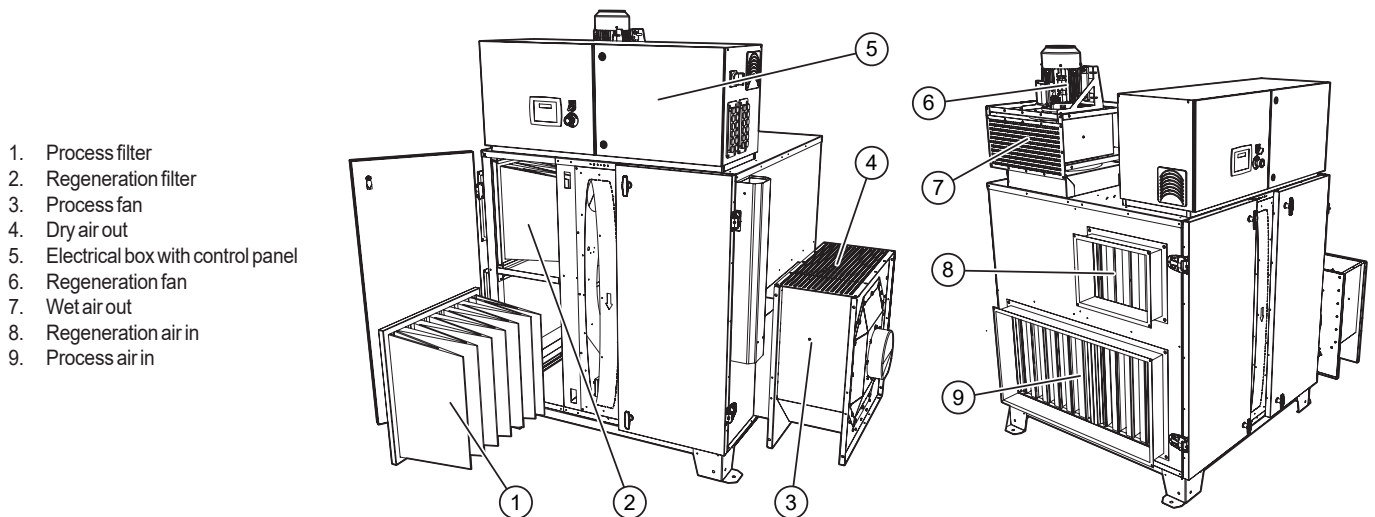

FIGURE 4: Product overview

Variation of installation and components may vary.

## 3.2 APPLICATIONS

DST desiccant-type dehumidifiers are normally used where dry air is essential to the various manufacturing processes used in chemical, pharmaceutical, food or confectionery industries, or where a dry environment is required for the storing and handling of moisture-sensitive products and raw materials.

The well proven air drying technology using the adsorption principle provides great flexibility in solving humidity problems. It offers the user independent humidity control, down to dew points far lower than the effective operating range of refrigeration dehumidifiers.

## 3.3 PRINCIPLE OF OPERATION

This is a continuous process with two air streams of different flow rates, normally having a flow ratio of approximately 3:1. The greater flow, *process air*, is dried as it passes through the dehumidifier, while the smaller flow, *regeneration air*, is used to heat the rotor material to drive the adsorbed moisture vapour from the desiccant. The moisture which is removed from the process air is transferred over to the other sector as the rotor slowly turns.

1. Wet air outlet
2. Regeneration air fan
3. Regeneration sector
4. Purge sector
5. Regeneration heater
6. Dry air outlet
7. Process air fan
8. Rotor motor
9. Process sector
10. Rotor
11. Process air inlet
12. Regeneration air in
13. Desorption process
14. Adsorption process
15. Water molecule
16. Silica gel

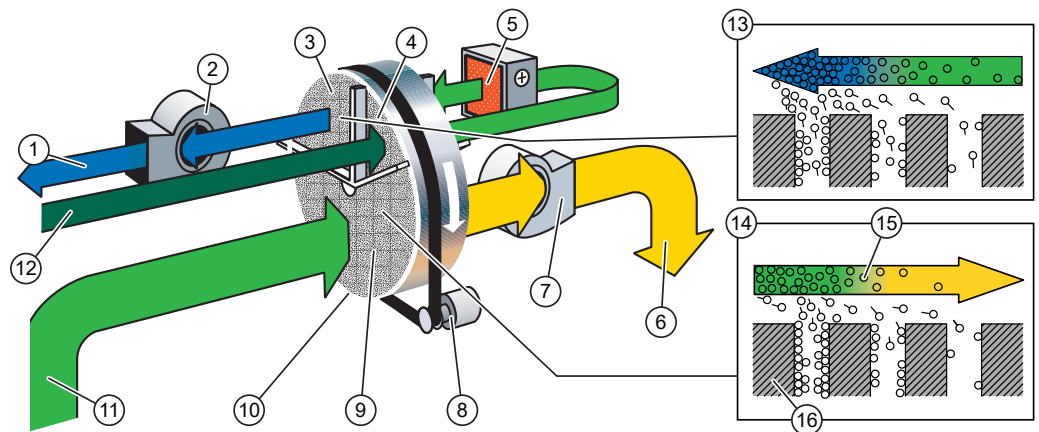

**RECUSORB Light** is a continuous dehumidifier with internal energy recovery and able to reach very low dew points. During regeneration, sensible heat is adsorbed by the rotor material. The rotor rotates and enters a small purge sector where part of the incoming regeneration air is pre-heated. As a result, the regeneration air is pre-heated before the air enters the regeneration heater, thus reducing the amount of energy to heat the air in the regeneration heater. Purge sector will also desorb some of the water molecules before the rotor enters the process sector.

Now that the excess heat in the rotor material is reduced by the purge sector. This will reactivate the rotor materials to prepare it for adsorption. When the rotor finally enters the process sector, the adsorbing starts immediately until the rotor passes over to the regeneration sector. In this sector the hot air will heat the rotor materials and desorbs the water molecules in to the air and exits through the wet air outlet.

FIGURE 5: Principle of operation & rotor

# 4 INSTALLATION

## 4.1 UNIT INSTALLATION

Follow the directions regarding installation of heavy and medium weight dehumidifiers.

**Note:** Use the installation guidelines as a reference only.

### 4.1.1 FORK LIFTING

The unit can be off-loaded and positioned using a fork lift by lifting between the feet of the unit, alt., on some dehumidifiers, lift the unit using the built-in handles.

- The forks must be of sufficient length to be in contact with both sides of the base frame.
- The forks should be initially positioned centrally across the middle sections of the unit but must be checked for balance prior to final lifting.
- Units equipped with handles are very heavy. Do not lift the unit single-handedly! Always ask for assistance or use lifting aid!

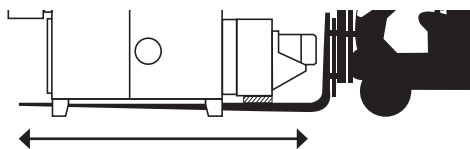

FIGURE 6: Forks in contact with both sides of the frame.

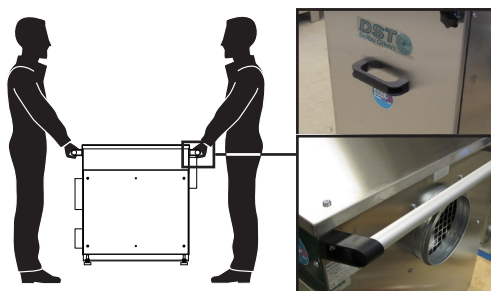

FIGURE 7: Units with handles

### 4.1.2 TRANSPORT

Dehumidifiers with external fans or a high centre of gravity runs the risk of tipping. Use caution when lifting and moving the dehumidifier.

**Note:**

- Secure any panels, doors or loose equipment.
- Keep the unit balanced at all times when moving the unit.
- See safety chapter regarding lifting safety.

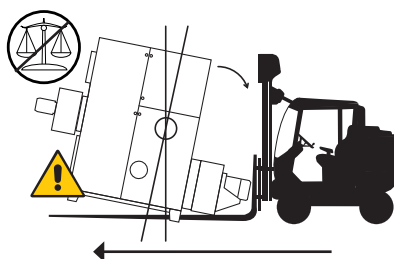

FIGURE 8: Exercise caution when lifting and transport a unit

*If not balanced, the unit may run the risk of tipping during transport.*

See "11 Technical data" for weight information.

### 4.1.3 POSITIONING

Position the machine with adequate working space around the unit to allow inspection and service. Size of unit and the position of the access panels/doors vary depending on the model. To avoid incorrect positioning, see the dimensional drawing in the appendix for service space and foot bolt-hole dimensions.

## 4.2 SECURING THE UNIT

**Note:** Applies for R-51/61, RZ and CZ only.

To allow securing of the dehumidifier to the floor or to a pedestal, four brackets with predrilled bolt-holes are included with the unit.

At delivery, the brackets are used to secure the unit to the pallet for transportation. Do not discard the foot brackets (!) Remove and reuse them if required.

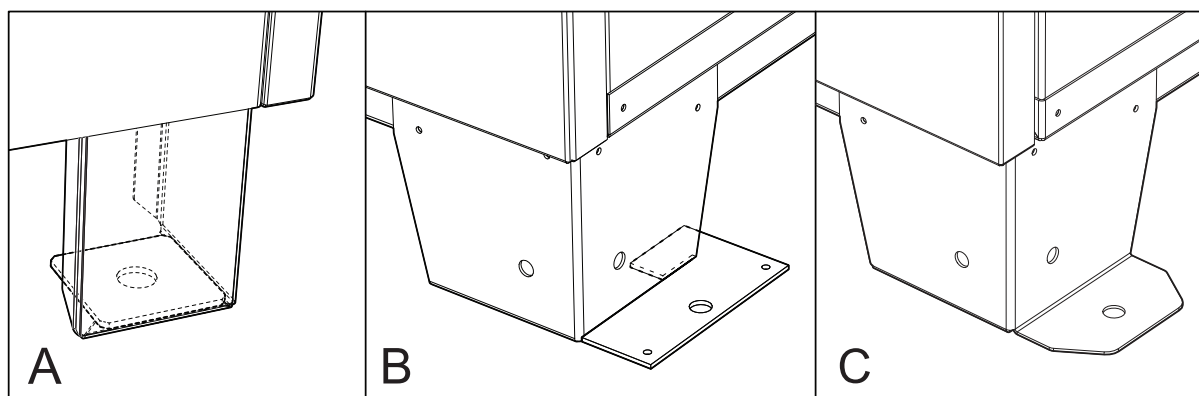

**FIGURE 9: Transportation bracket**

A) R-51/61 B) RZ/CZ C) RLZ

**Note:** RLZ has integrated brackets to fix the unit onto a pallet or a foundation.

## 4.3 GENERAL DUCT WORK INSTALLATION

The guidelines are to assist the installers and operators to adjust the duct/dehumidifier installation. Consult a DST representative or local mechanical installation company for more information.

- Avoid recirculation from the separate airflows, direct entering and exiting airflow away from each other.
- Check if the dry air is well distributed in the dehumidified area.
- The regeneration air in and wet air out has to be connected to the outside of the dehumidified area, preferable outdoor.
- To increase the lifetime of the filter, it is recommended taking air from a higher level where dust and other particles are kept at minimum.
- Install dry air out duct/channel at a high level.
- To maximize the drying capacity, free blowing on dry air out without airflow reduction is recommended.
- Allow wet air to disperse freely when exiting the duct.
- It is recommended to insulate the wet air duct.
- The wet air duct must be installed at a sloping outwards angle, due to risk of condensation inside the duct work. The setup will also prevent condensation flowing back into the dehumidifier.
- If the duct needs to be installed higher than the wet air outlet, fix a condensate drain at the lowest point of the duct.
- Do not connect the air outlet to a ventilation system which can create pressure that will result in reverse airflow through the dehumidifier.

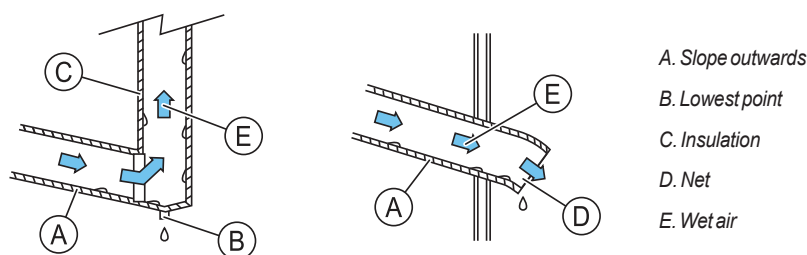

**FIGURE 10: Installation of wet air out duct**

## 4.4 DAMPER INSTALLATION

When installing dampers to adjust the airflow to nominal flow, it is recommended to place the dampers according to the table. Installing dampers on the wrong side might result in humid air mixing with dry air through infiltration between the air chambers and affect the capacity. Always maintain a higher pressure on the process air chamber than the regeneration air chamber by adjusting the dampers.

Inlet/Outlet side	Install dampers
Regeneration air inlet	•
Wet air outlet	○
Process air inlet	○
Dry air outlet	•

## 4.5 PIPE WORK CONNECTIONS

Pipe work should be connected in accordance with good engineering practise and ensure connections is made to screwed fittings on the unit. Follow the mandatory and recommended piping installation.

### 4.5.1 STEAM INSTALLATION AND SCOPE OF SUPPLY

To ensure failure-free operation, DST recommends the external steam supply connection and setup as followed. DST will not be held accountable for any hardware damage that might occur if the recommendations are not complied.

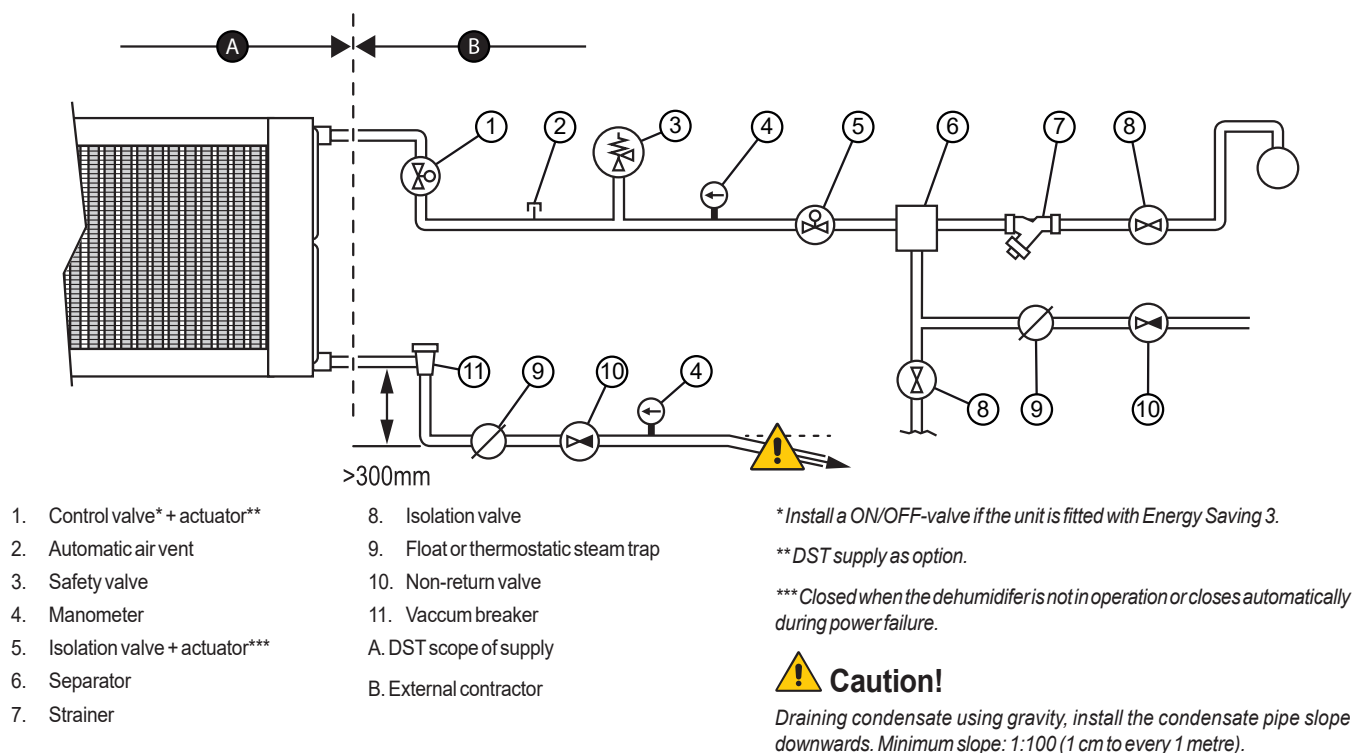

FIGURE 11: Steam coil and pipe installation

During installation, the installers "MUST" configure the condensate pipe with vertical drop of >300mm to prevent condensate water flowing into the coil and an control valve + actuator (optional).

It is the responsibility of the steam system installer to ensure that condensate is effectively drained from the coil under all load conditions. Failure to comply will result in premature failure of the coil and invalidate the warranty.

### ⚠ Attention!

Standard steam coil information:

- Maximum working pressure: 10 Bar
- Test pressure: 13 Bar
- Maximum operating temperature: 185°C
- Saturated steam: >0.95DF
- If condensate temperature on outlet pipe is <7°C, equip the steam coil with a frost protection device.

## 4.6 LIQUID MEDIUM COIL INSTALLATION

Connect the supply pipe to the inlet pipe towards the exiting airflow of the coil, and the return pipe to the outlet pipe towards the entering airflow. The unit is labelled for guidance.

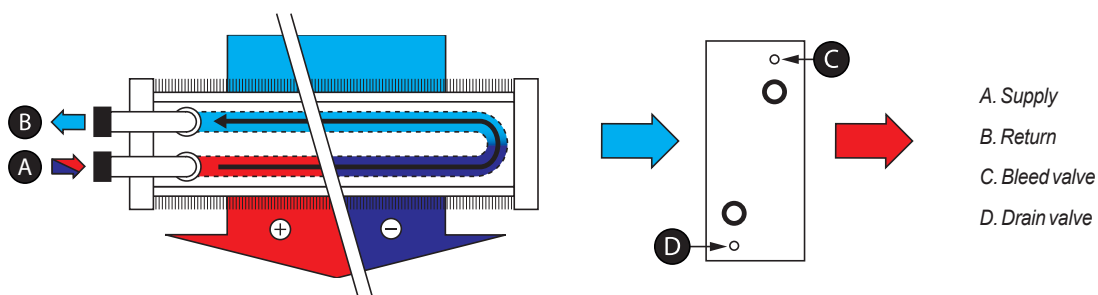

FIGURE 12: Hot and cold water coil

### ⚠ Caution!

If fitted with hot/warm water coil, water temperature on the return end will not be regulated. Install external temperature regulating devices if necessary (not supplied by DST).

## 4.7 HUMIDISTAT/ELECTRONIC CONTROLLER INSTALLATION

Install the humidistat/electronic controller away from the dry air out path to avoid false readings.

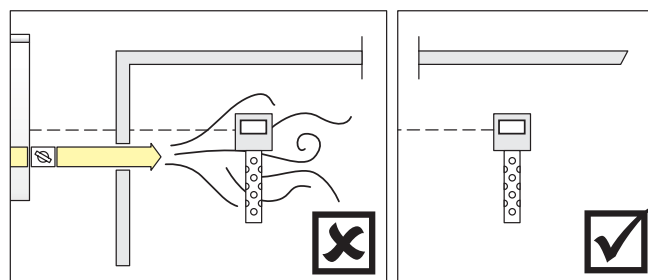

FIGURE 13: Humidistat positioning

## 4.8 ELECTRICAL CONNECTION

Electrical components should be connected to the supply according to the local regulations and requirements.

### 4.8.1 POWER SUPPLY

The incoming three-phase cable with L1, L2 and L3 are directly connected to the main switch and PE-cable connected to the earth bar.

The electrical feed must be provided on-site in accordance with the electrical diagram and local requirements.

See electrical diagram for a detailed layout and description.

### 4.8.2 EARTH LEAKAGE CIRCUIT BREAKER

Due to the high capacitive currents present in the AC drive, earth leakage circuit breakers may not function properly.

**Note:** This is only applicable if the unit is equipped with a frequency converter.

### 4.8.3 HUMIDISTAT CONNECTIONS

The dehumidifier has a connection for a 1-step\* or 2-step\*\* humidistat. This is optional for some models.

See electrical diagram for connections.

See "7 Functions" for more details.

\* For models with no selectable heater output.

\*\* For models with at least two selectable heater output.

### 4.8.4 0-10VDC SIGNAL

Units with optional connections points for an electronic humidity controller or another regulator signal is marked on the electrical diagram.

See "7 Functions" for more details.

See electrical diagram for connections.

### 4.8.5 REMOTE CONTROL

The unit has a connection point for a remote switch.

See electrical diagram for connections details.

See "7 Functions" for more details.

### 4.8.6 POTENTIAL-FREE SIGNALS

Potential free contacts are marked on the electrical diagram for connecting external indicators. These indicators are used to transmit signals to a remote centre, to indicate if unit or fans are still in operation.

#### Standard indicator

- Alarm indicator
- Run indicator\*
- Regeneration fan indicator\*
- Process fan indicator\*

#### Optional indicators (N/A for certain units)

- Filter guard (regeneration) indicator
- Filter guard (process) indicator
- MAN/AUTO indicator

Each indicator, standard or optional, are marked on the electrical diagram to indicate whether it is a normally closed or a normally opened circuit.

\* Standard indicator may differ depending on model and configuration. See electrical diagram for more information.

# 5 OPERATION CHECK & ADJUSTMENT

---

## 5.1 PRE-OPERATION CHECK

---

### **Danger!**

The operator of the system must ensure that all personnel who are involved with installation, operation and maintenance of the machine have read the "1 Safety" sections of this manual.

1. Inspect and clean the inside of the unit from foreign objects such as rags, tools, particles of metal, and such, that may pose damage to the inside of the unit.
2. If fitted, ensure that both air balance dampers are fully open and check that the air paths of the duct work are not obstructed in any way.
3. Check that the filters are securely in place.
4. Confirm both motor overload protectors are set to Start/On position.
5. If fitted with condenser or cooler, install a water trap.
6. Confirm thermostat and overheat protection settings are in accordance with table shown "11 Technical data".
7. Confirm the incoming electrical power cable is secure and ensure that live wires are securely located in the correct terminals. Ensure the earth wire is securely located onto the earth strap or earth terminal provided.
8. Check that the rating of the electrical supply fuses is correct, see wiring diagram.

## 5.2 START-UP TEST AND ADJUSTMENT

---

1. Close and secure all access doors
2. Switch the main switch to "I" and check the supply voltage is correct.
3. Briefly start the unit and then turn it off. Promptly check if the process fan and regeneration fan is rotating in the correct direction. If incorrect check "9 Troubleshooting". See "6 Operating" on "Start" and "Stop".
4. If fitted, balance the airflows, using the dampers in the duct work or adjust the frequency of each frequency converter to obtain the required values.
5. Check the operation of fault alarms by temporarily reducing the setpoints of alarm giving thermostats and motor protectors. Do not forget to reset to the original settings according to technical data and electrical diagram.
6. Measure the current on both fans and compare with the electrical specifications printed on the fan motor casing. If the current is too high, reduce the airflow slightly by closing down on the respective balance damper.
7. If connected, check remote control operation.
8. If connected, check remote alarm function (see 5 above).
9. If connected, check humidistat/electronic humidity controller function.

# 6 OPERATING

## 6.1 KEYS

1. **[MAN/AUTO]** - Enable or disable the humidistat/external regulator control
2. **[EMERGENCY STOP]** - Stops the unit in case of emergency
3. **[ON/1]** - Start
4. **[OFF/2]** - Stop
5. **[Heater/5]** - Heater power output setting
6. **[Temp/7]** - Temperature setting for TH2, TH3 and PID-values\*
7. **[Mode/8]** - Airflow setting in ventilation mode
8. **[Hour-proc/9]** - Run time for process fan
9. **[Info/6]** - Function description
10. **[Hour-reg/0]** - Energiconsumption for heaters in kW
11. Navigation keys
  - [▲]** - Present value, software version and browse up
  - [▼]** - Setpoints and browse down
  - [▶]** - Browse right
  - [◀]** - Browse left
12. **[↵]** - Select choice, confirm choice
13. **[i]** - Display firmware information

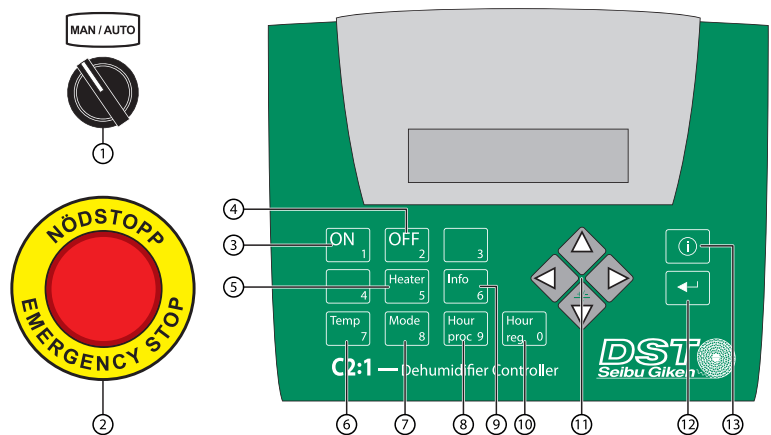

FIGURE 14: PLC-keys

There might additional controls such as indicators for alarm and filter guards- See the provided electrical diagram for the individual unit for more information.

\*Applicable for units with Energy Saving 2 only

## 6.2 START

The unit will initiate starting sequence by activating the process fan, rotor motor, reg. fan and heaters.

- The start-up will last for 15 seconds.

1. Select mode: "MAN" or "AUTO" on **[MAN/AUTO]** switch (Use "AUTO" if a humidistat/external regulator is connected, use "MAN" if else).
2. Press **[ON/1]**. Display shows "Starting up" and the unit will initiate starting procedure.

## 6.3 STOP

The unit will start to shut down and come to a complete stop.

- During shut down, the regeneration fan and rotor motor will continue to run for a pre-set time as a part of a cooling stage.

- During "REG FAN OFF DELAY", press **[↵]** to return to start display.

1. Press **[OFF/2]**.

## 6.4 ENERGY CONSUMPTION - HEATERS

Monitors the total energy consumption in kW of the heater.

- Feature available for electric heater only.

- Can only be used during operation.

1. Press **[Hour-reg/0]** to view total energy consumption.
2. Press **[Hour-reg/0]** again to exit.

## 6.5 RUN TIME - PROCESS FAN

Monitors the running time for process fan.

- Can only be used during operation.

1. Press **[Hour-proc/9]** to display run time for process fan.
2. Press **[Hour-proc/9]** again to exit.

## 6.6 CHECK TEMPERATURE

Check the temperature on regeneration heater and wet air out.

- Other configuration settings will be displayed after the temperature display.

1. Press and hold **[▲]** to display regeneration temperature (TH2).
2. Press **[↵]** to view wet air temperature (TH3).
3. Press **[↵]** repeatedly to exit.

## 6.7 SETTINGS

Various settings and values for regulator, ventilation and control thermostat TH2 and TH3.

- Unit without electrical heater and gas heater is not equipped with TH1.
- TH1 will not be displayed since it is a mechanical overheat protector. It is located inside the electrical cabinet.
- The adjustment can only be set when the unit is turned off.

1. Press and hold **[Temp/7]** until the menu shows up.
2. Enter the password (1919) with the numerical keys and press **[↵]**.
3. Enter TH2 temperature setting by pressing the numerical keys.
4. Press **[↵]** to confirm and **[↵]** again to continue.
5. Enter TH3 temperature setting by pressing the numerical keys.
6. Press **[↵]** to confirm and **[↵]** again to continue.
7. Enter the PID\* by pressing the numerical keys and confirm each variable by pressing **[↵]** to confirm.  
**Note:** RLZ only with ENII.
8. Press **[↵]** to confirm and **[↵]** again to exit.

\*Factory default setting P: 100, I: 50, D: 1.



### Caution!

Under some circumstances, it is possible to use the the factory default settings on the regulators, but it is not recommended. Regulators will not work optimal for the intended application and might result in imprecise dehumidification, premature wear on components and increased energy consumption. Always adjust the regulators for optimal performance.



### Caution!

Do not set TH1, TH2 and TH3 temperature setting beyond the recommended value stated in the technical data. Consult DST-representative before changing the setpoints.

## 6.8 PROCESS AIRFLOW SETTING

Set the process airflow capacity for the dehumidification mode and ventilation mode.

- Can only be used during operation.

  1. Press and hold **[Mode/8]** until the menu shows up.
  2. Input the process fan airflow in % for the dehumidification mode by pressing the numerical keys.
  3. Press **[↵]** to move to the next setting.
  4. Input the process fan airflow in % for the ventilation mode by pressing the numerical keys.
  5. Press **[↵]** to confirm and **[↵]** again to exit.

## 6.9 HEATER POWER OUTPUT SETTING

Select the number of active heater modules.

- Feature available for electric heater only.
- The adjustment can only be set when the unit is turned off.

  1. Press **[Heater/5]** to enter menu.
  2. Input the number of active\* heater modules by pressing the numerical keys.  
**Note:** If Energy saving 2 is fitted, input the heater power in percentage by pressing the numerical keys.
  3. Press **[↵]** to confirm and **[↵]** again to exit.

\*Step 1 activates one heater group (57 %) and step 2 activates all heater groups (100 %).

## 6.10 INFORMATION

During non-operation, check the configuration according to the specification.

1. Press and hold **[Info/6]** until the menu shows up.
2. Pressing **[Info/6]** to move to the next status screen\*.
3. Continue pressing **[Info/6]** to exit.

\*Due to the PLC's text limitation, additional explanations are shown here: CV1: Humidity regulator, CV2: TH2 regulator, CV3: TH3 regulator.

## 6.11 RESET THE PLC

Once the error has been corrected, use the PLC to reset itself and restart the unit. If the unit does not start up, check the display for errors and correct it.

- The adjustment can only be set when the unit is turned off.

  1. Press **[OFF/2]** to remove the error on the display.

## 6.12 PLC OPERATION MESSAGES

During operation the following messages may appear on the PLC. These messages are not to be confused with PLC error codes.

MESSAGES DURING OPERATION			
<b>STARTING UP FILTERS OK</b>	Initiating the start-up sequence and checking filters.	<b>OPERATION EH3</b>	When the attached electronic humidity controller EH3 is giving off a signal of 0.5V or lower in a period 5 minutes or more.
<b>STARTING UP DIRTY FILTER</b>	Initiating the start-up sequence. Change process or regeneration filter.	<b>OPERATION TH2 Reg temp ##°C</b>	When the maximum temperature of TH2 has been reached. The PLC deactivates the heater step by step to reduce the temperature.
<b>STARTING UP SYSTEM OK</b>	Initiating the start-up sequence. All system are fully operational.	<b>OPERATION REMOTE</b>	The connected remote has shut down the dehumidifier.
<b>STARTING UP HUMIDISTAT1 OPEN</b>	Starting up with dehumidification capacity turned off in auto-mode (Overrides Humidistat 2).	<b>UNIT STOPPED BY LOW HUMIDITY</b>	Dehumidification capacity turned off in auto-mode. Humidistat 1 is open (Overrides Humidistat 2).
<b>STARTING UP HUMIDISTAT2 OPEN</b>	Starting up with reduced dehumidification capacity in auto-mode.	<b>HUMIDISTAT 2 INPUT OPEN</b>	Operating with reduced dehumidification capacity in auto-mode.
<b>STARTING UP REMOTE OPEN</b>	The connected remote is open during start-up sequence.	<b>STOP LOW HUMIDIT VENTILATION: 50%</b>	When the attached external regulator is giving off a signal 0.5V or lower in a period 5 minutes. Process fan is set to operate at 50% in ventilation mode.
<b>OPERATION ##kW [MODE]</b>	During operation, the output will vary depending on the size of the unit. No output is displayed if the unit is installed with coil heater. Selected dehumidification [MODE] during operation.	<b>REGFAN OFF DELAY ### C ### s</b>	During shut down or standby (if an external regulator is connected or humidistat 1 & 2 is opened). The display will also show the current heater temperature and countdown until the regeneration fan stops.
<b>OPERATION ##kW REG. FLOW TOO LOW</b>	Unit is running, no regeneration heater is active due to low regeneration airflow.		
<b>OPERATION XX% ↓ AUTO MODE</b>	The "XX%" is the control signal from the humidity regulator. The arrow indicates that the TH2 or TH3 regulator has override the humidity regulator for the time being. To check TH2 or TH3 control signal, see "6.10 Information".		

FIGURE 15: PLC operation messages

## 6.13 RESET BUTTONS & SWITCHES

Fuses, overheat protections or motor protectors are found inside the electrical cabinet. The position and denotation of the devices may vary depending on the unit and configuration.

Reset is only required when a operation is halted by hardware failure or triggered a safety mechanism. See troubleshooting for more information.

See the electrical diagram for correct layout and information of the reset devices.

# 7 FUNCTIONS

## 7.1 DEHUMIDIFICATION FUNCTION

The unit is equipped with multiple modes to control the dehumidification. It allows automatic control with connected humidistat or regulator signal\*, or manual override. A selectable option to set the ventilation modes during automatic mode is also possible.

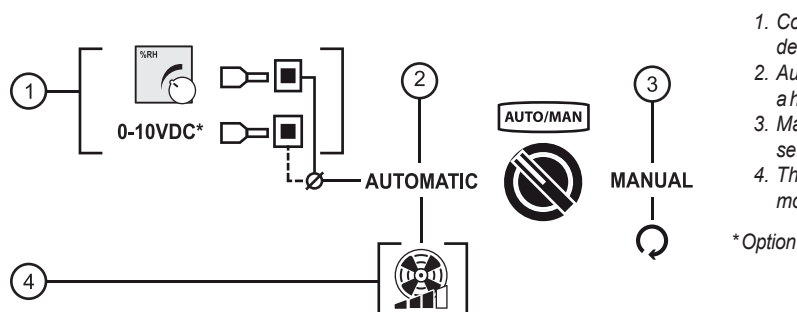

1. Connections for a humidistat or regulator signal when controlling the dehumidification.\*
2. Automatic control - Dehumidification is automatically controlled using a humidistat or regulator signal
3. Manual control - Dehumidification is manually controlled using pre-set settings.
4. The airflow on the process fan is adjustable for the dehumidification mode and ventilation mode.

\* Option

FIGURE 16: Illustration of automatic and manual functions

### 7.1.1 AUTOMATIC OR MANUAL

Main operation control is operated by selecting automatic or manual mode on the [AUTO/MAN]-switch.

**AUTOMATIC [AUTO]** - Dehumidification capacity is controlled automatically by a humidistat/regulator signal. In this mode, the process airflow is adjustable from 0% to 100% when the unit switches from dehumidification to ventilation. The user can either set the fan to OFF (0%) or adjust to it 100% or less.

**MANUAL [MAN]** - The unit will run on selected settings until manually turned off. This mode will also prevent a humidistat or a regulator signal from shutting down the unit.

**Note:** Electrical heater output is selectable. Available for certain models only. See "6 Operating".

**Note:** AUTO-mode is only operable when a humidistat/regulator signal is connected.

**Note:** If the unit is fitted with Energy saving, the regeneration heater will operate on full effect in MAN-mode.

### 7.1.2 AUTOMATIC MODE - AIRFLOW

Dehumidification is controlled automatically using a humidistat/regulator signal. In this mode the process airflow capacity is adjustable if the unit is dehumidifying or ventilating. The factory default settings for process airflow capacity is set as followed and is adjustable on the PLC.

Dehumidification airflow	Ventilation airflow
100%	50%

**Note:** When operating in manual mode, settings for ventilation airflow settings is disabled.

### 7.1.3 HUMIDISTAT CONNECTION

Standard units have the option to use the built-in Humidistat inputs to control the dehumidification using a 1-step or 2-step humidistat.

The built-in humidistat controls the dehumidification by reducing the regeneration heater in steps. Use a 2-step humidistat to control the heater output in three steps (maximum power, reduced power and zero power) or a 1-step humidistat for heating output in two steps (maximum power and zero power).

Mode	Two-step humidistat (Applies for electrical heater)		One-step humidistat (Applies for steam heater)	
	Humidistat inputs	Heater output	Humidistat input	Heater output
1	Humidistat step 2 (Closed) Humidistat step 1 (Closed)	Full power	Humidistat (Closed)	Full power
2	Humidistat step 2 (Opened) Humidistat step 1 (Closed)	Reduced power*	N/A	N/A
3	Humidistat step 2 (Opened) Humidistat step 1 (Opened)	Zero power	Humidistat (Opened)	Zero power

\* See technical data for details on electrical heater output for reduced power.

See electrical diagram for details and connections.

### 7.1.4 0-10VDC CONNECTION

**Note:** Option

This feature replaces the standard built-in humidistat inputs when Energy saving 2 or 3\* is fitted. A 0-10VDC regulator is used to control the dehumidification capacity on a precision level when the built-in Humidistat input feature is insufficient.

Electronic humidity controller	Regulator signal	Capacity output
EH3 T2/others	0...10VDC	0...100%

See electrical diagram for customer connection.

\* N/A for R-51/60/61, RL-60/61/71.

See "8.8 Energy saving" for more feature description.

## 7.2 REMOTE CONTROL SWITCH

Connections for an external power switch is available as standard. The remote power switch allows the user to shut down or turn on the unit from another location.

**Note:** The external power switch overrides the manual and automatic mode and must be restored to start the unit.

See electrical diagram for connections.

## 7.3 TEMPERATURE SAFETY DEVICES

Integral "fail-safe" temperature devices will protect the unit from damage caused by component failure, incorrect settings or abnormal operating conditions.

Type	Thermostat function	Thermostat description	Thermostat location	Reset is required
TH1	Safety thermostat	An overheat protection device that stops the unit if the temperature exceeds the set limit	Inside the regeneration heater compartment	Yes
TH2	Control thermostat	A device that controls the set regeneration temperature	Inside the regeneration heater compartment	No
TH3	Safety thermostat	An overheat protection device that stops the unit if the temperature exceeds the set limit	In the proximity of wet air outlet	Yes

Temperature device types used will vary between models fitted with a PLC and those without a PLC. See below.

Units with PLC	Units without PLC
Two shielded electronic sensors, programmed on PLC as TH2 and TH3. Reset TH3 on PLC. Mechanical thermostat TH1* – reset on thermostat.	Only mechanical thermostats installed - TH1, TH2 and TH3 Mechanical thermostat TH1* and TH3 - reset on thermostats.

*\*N/A when fitted with coils.*

See "11 Technical data" for default temperature settings.

See electrical diagram for the location of the thermostats.

### ! Attention!

*If TH1 or TH3 are tripped, an automatic safe shut down procedure will be initiated. On units fitted with a PLC an alarm code will be displayed. On units without a PLC an alarm is indicated by a red light on the control panel. The shut down procedure includes a timed cooling down period and, if fitted, closing of associated valve actuators.*

### ! Attention!

*Should TH1 trip, it will automatically disable the regeneration heater circuit breakers. These must be reset before attempting to restart the unit.*

## 7.4 PRESSURE NOZZLES

Pressure nozzles can be used to control or monitor airflows, using gauges or pressure sensitive devices. The air nozzles are marked on the unit.

## 7.5 REGENERATION AIRFLOW GUARD

The fail-safe device automatically turns off the the regeneration heater from overheating due to insufficient regeneration airflow. The pressure switch is adjustable but it is not recommended. See "11 Technical data" for default setting.

The airflow guard is a warning only and will not shut down the unit or turn on a alarm light. If there is a potential reduced capacity, see "9.3 Capacity troubleshooting" to locate the issue.

## 7.6 FREQUENCY CONVERTER TO FANS

The frequency converter is used to set the desired airflow without dampers and reduce start-up current.

See electrical diagram for more information and location of the frequency converter.

**Note:** Due to the high capacitive currents present in the AC drive, earth current leakage breaker may not function properly.

# 8 OPTION & ACCESSORY

## 8.1 FROST PROTECTION DEVICE

Monitors the return water temperature from the coil and sound an alarm to the control panel.

The device will close the dampers at the regeneration air in and wet air out and sound an alarm if the temperature of the return water is below a certain temperature.

The alarm temperature can be changed via a potentiometer, which is located in the cabinet. This is not recommended, consult a DST representative for more information.

See electrical diagram for more information on the devices.

Available for hot/warm water and steam coil only.

See "10 Technical data" for temperature setting.

## 8.2 FILTER GUARD

Filter guard is a pressure indicator which tells the condition of the filter. Different options are available for purchase and comes in different varieties, such as a mechanical (differential U-tube manometer) or an electronic filter guard.

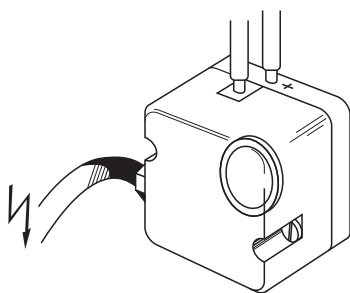

**FIGURE 17: Electronic filter guard**

*If the differential pressure increases beyond the recommended value, the filter needs to be replaced as soon as possible. This is indicated by warning light or a message on the PLC.*

*See "11 Technical data" for recommended pressure for each filter type.*

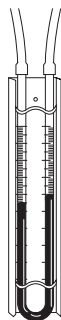

**FIGURE 18: Manometer - mechanical filter guard**

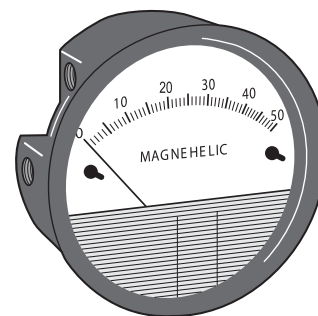

**FIGURE 19: Manometer - mekanisk filtervakt (Magnehelic)**

## 8.3 ROTATION GUARD

A safe guard feature that stops the unit from overheating in case of a sudden stop in the rotor rotation. The rotation guard will stop the unit and turn on an alarm indicator or display an error message on the PLC.

**Note:** Included in Energy saving 2 and 3.

## 8.4 ADJUSTABLE ROTOR SPEED

Stepless setting of the rotor speed. Manually controlled from the PLC or a control box with a built-in potentiometer.

## 8.5 INSULATION

19mm or 32mm (foamed rubber) insulation can be added along the inside of the process air compartment or regeneration air compartment, or both to prevent possible condensation on the inside or the outside surface of the unit.

## 8.6 REACTIVATION HEATER COILS

Optional heating other than standard electrical or steam heating are available.

**Note:** Control valve is included in the delivery.

## 8.7 ICE-FAN

If an increased airflow is needed, the standard process can be replaced and fitted with a powerful ICE-fan.

**Note:** A frequency converter may be required for certain models.

Data flow and other technical data is located in the datasheet.

## 8.8 ENERGY SAVING

To save energy, the unit can be fitted with different “Energy saving” features.

**Energy saving 1:** The reactivation heater power output is regulated in two steps. Using a EH3 T2 or EH4 to adjust the drying capacity between High, Low & Off, as required to maintain the humidity (or dew point) between two programmable setpoints.

**Energy saving 2:** The reactivation heater power is fully regulated between zero and full capacity using either binary (multi-step) or linear (triac or actuator) control. Using a humidity controller EH3 T2 + PLC C2 or an external control signal (BMS + PLC C2), the drying capacity is finely adjusted to accurately maintain the required setpoint (humidity or dew point).

**Energy saving 3:** Used on steam reactivated dehumidifiers only. The reactivation air fan is regulated between 20% and full flow using a motor frequency inverter. The reactivation temperature is maintained at a high level. Using our humidity controller EH3 T2 + PLC C2 or an external control signal (BMS + PLC C2), the drying capacity is finely adjusted to accurately maintain the required setpoint (humidity or dew point).

Contact a DST representative to view the energy saving option for each specific unit as options across the products range may vary.

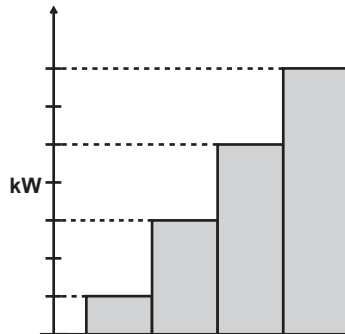

**FIGURE 20: Binary control**  
Example of binary control with heater output controlled in steps.

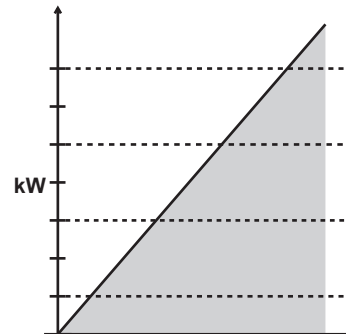

**FIGURE 21: Linearly control**  
Example of linearly control for linear heater output.

See “11 Technical data” for binary heating steps.

## 8.9 HUMIDITY CONTROLLER

Control the dehumidification process using the advanced electronic humidity controller EH3 T2 or the simpler electronic humidistat EH4. The devices can be built in the electrical box next to the control panel or loose device for on-site installation.

See “8.8 Energy saving” for more information on what features they can be installed on.

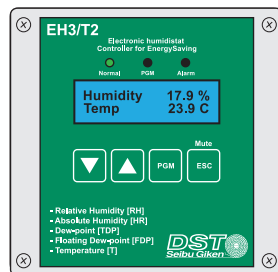

**FIGURE 22: EH3 T2**  
Electronic humidity controller with multiple settings and advanced control for dehumidification,

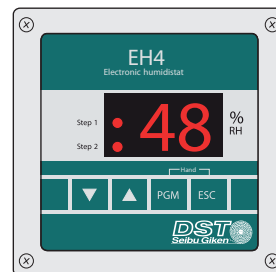

**FIGURE 23: EH4**  
2-step humidistat for less demanding dehumidification control.

**Note:** Data sheet and user’s manual is available separately.

# 9 TROUBLESHOOTING

## 9.1 ERROR CODES

The dehumidifier will automatically shut down if an error is detected. During shut down, a timed cooling down period on the regeneration fan is initiated before turned off. See below for error codes.

CODE	EXPLANATION	CAUSE	SOLUTION
Fuse F1 or F2	Process fan overloaded.	Excessive airflow.	Check fan.
Motorst Q1 or Q2	Regeneration fan overloaded.	Short-circuit or fan malfunction.	Check setpoint of Q1/F1 or F2/Q2. Reset F1/Q1 or F2/Q2 – check and adjust airflow. Have a qualified electrical technician to investigate.
Fuse F3-5 or TH1*	Regeneration air thermostat TH1 has tripped.	TH1 setting incorrect. TH1 defective (fail safe). Incorrect shut down.	Check TH1 setting. Check correct operation of TH1. Reset TH1 - reset F3 - F5.
Fuse F5 or TH1*	Regeneration heater overloaded.	Insufficient regeneration airflow. Excessive regeneration heater power. Regeneration heater malfunction.	Check regeneration airflow and fan operation. Check TH2 setting. Check and replace heater.
Thermal fuse TH4	Solid state relay overloaded or overheated.	High power consumption. Insufficient cooling.	Check Solid State Relay cooling - fan and heat sink.
TH4 Heat sink Temp >80°C			Check ventilation in electrical cabinet - Filter & fan. Check Solid State Relay function. Automatic reset - Temperature <80 °C. Have a qualified electrical technician to investigate.
Frost guard GT81	Frost protection device has tripped and stopped the machine.	Temperature on the hot water outlet or condensate outlet is below 7°C.	Check water supply and insulation for potential thermal loss.
Wet air temp TH3	Wet air thermostat tripped (TH3).	TH3 setting incorrect. Excessive regeneration airflow. Excessive regeneration heater power . Incorrect or intermittent rotor rotation. Insufficient system moisture load.	Check TH3 setting. Check and adjust regeneration airflow. Check TH2 setting. Check rotor drive system. Check process airflow and fan operation. Check process inlet moisture content. Check RH controller setpoint/output control signal. Reset TH3.
Flow guard fault	No activation signal from the pressure switch.	Faulty pressure switch. No electrical feed to pressure switch	Check pressure switch. Check electrical wire and power
Rotor stopped	Rotation guard sensor has not detected movement.	Rotor drive system failure. Sensor failure or incorrect clearance.	Check drive motor & transmission (correct belt tension). Check clearance gap between sensor and rotor marker.
Fr. converter U1	Frequency converter alarm.	Frequency converter internal alarm activated .	Refer to converter manual for fault code explanation.
Fr. converter U2			
Emergency stop	Operation terminated.	Emergency button activated.	Pull the emergency button to restore.

\* Not applicable when fitted with steam.

FIGURE 24: Troubleshooting table and solution

## 9.2 GENERAL TROUBLESHOOTING

Check for following if the unit will not start-up.

PROBLEM	CAUSE	SOLUTION
Unit will not start. PLC is displaying nothing.	No power to unit. No power to control circuit. The emergency stop button is active.	Confirm electric supply and check local isolator is on. Check remote control is set to 'On/Run' position. Check all circuit breakers are set to 'Start/On' position. Have a qualified electrical technician to investigate. Pull the emergency stop button.
The PLC is displaying an error, but the unit will not start.	Alarm circuit is preventing start-up.	Check error on PLC - Restore error and reset PLC.
The PLC is displaying a message or error, but the dehumidifier does not appear to be operating.	A circuit is preventing operation.	Check message on PLC - Correct error and reset PLC. See troubleshooting "9.1 Error codes" eller "6.12 PLC operation messages". Operation can be checked by lowering control setpoint or switching to 'manual' operation. Check remote control is set to 'On/Run' position and if the cable is undamaged.
The PLC is displaying a message, but the dehumidifier appear to be operating.	A circuit is preventing operation.	Check message on PLC - Correct error and reset PLC. See troubleshooting "6.12 PLC operation messages".

FIGURE 25: General troubleshooting table and solution

## 9.3 CAPACITY TROUBLESHOOTING

The dehumidifier performance can be roughly checked by feeling the temperature of the uninsulated duct work near the unit.

PROBLEM	OBSERVATION	SOLUTION
The dehumidifier does not maintain required condition or achieve expected performance, despite being operated at full power.	Dry air outlet duct is warm and wet air outlet duct is very warm (normal operation).	Check actual moisture load against calculated design moisture load. Check controller setpoint/output signal. Check airflows are set as specified, adjust as necessary. Check air filters. Check dehumidifier casing and duct work for air leakage. Check rotor alignment and condition of radial and peripheral rotor seals.
	Both outlet air ducts are cold (no alarm).	Check regeneration airflow and fan operation. Check regeneration heater operation. Check controller setpoint/output signal. Check TH2 setting.
	Dry air outlet duct is cold, wet air outlet duct is hot (no alarm).	Check rotor rotation. Check process airflow and fan operation.
	The regeneration heater light indicator is not turning on or flashing.	Check regeneration airflow - Remove blockages or open dampers on the regeneration airflow. Check pressure switch and setting. <b>Note:</b> N/A for R-51/60.
	None or low regeneration airflow is detected.	Check regeneration fan. Check TH2 thermostat and setting. Check TRIAC and cooling fan.
Measured airflows are lower than specified.	Fan is not rotating in direction indicated by arrow on fan motor casing. The incoming phase supply is incorrect.	Isolate mains electrical power supply to the unit. Change over two of the three incoming phase supply wires. Re-check fan rotation.

FIGURE 26: Capacity troubleshooting and solution table

# 10 MAINTENANCE

## 10.1 REGULAR SERVICE INTERVAL

Service time	Run time in hours (x1000)	0	4'	8'	12'	16'	20'	24'	28'	32'	36'	40'	44'	48'
	Calendar time in months	0	6	12	18	24	30	36	42	48	54	60	66	72
Inspect filter - replace if necessary		X	X	X	X	X	X	X	X	X	X	X	X	X
Clean and inspect the unit				X		X		X		X		X		X
Inspect fan - replace if necessary				X		X		X		X		X		X
Inspect features and functionality		X		X		X		X		X		X		X
Inspect electric, feature, cables and electrical components - replace if worn or damaged				X		X		X		X		X		X
Inspect access panels, locks and panel seals - replace if necessary				X				X				X		
Inspect duct and duct connections		X				X				X				X
Inspect heater and cooler				X		X		X		X		X		X
Inspect humidistat/humidity sensor - replace if necessary				X		X		X		X		X		X
Inspect rotor motor - replace if necessary				X		X		X		X		X		X
Inspect radial & peripheral seals - replace if worn or damaged				X		X		X		X		X		X
Check operation of geared drive motor, drive pulley, belt/chain, rotor - adjust as necessary				X		X		X		X		X		X
Inspect rotor for contamination or damage - clean/repair (contact DST)		X		X		X		X		X		X		X
Inspect condenser*				X		X		X		X		X		X
Inspect evaporator*				X		X		X		X		X		X
Inspect compressor*				X		X		X		X		X		X
Inspect cooling system*		X		X		X		X		X		X		X

Safety feature check (if fitted)														
Function test on thermostats			X		X		X					X		X
Function test on the freeze alarm	X		X		X		X		X		X		X	X
Function test on rotation guard alarm, check and adjust sensor clearance	X		X				X					X		
Function test on damper, actuator and valves	X		X		X		X		X		X		X	X
Function test on post-cooling function	X		X		X		X		X		X		X	X

FIGURE 27: Service chart

This is a general service chart and the time interval vary depending on the operating condition. Some options listed here may not be installed or available for this specific unit.

### Danger!

All personnel involved with installation, operation and maintenance of this unit should familiarise themselves with the safety section of this manual.

\*Applicable for Frigosorb and Econosorb.

## 10.2 WASHING THE ROTOR

The D-MAX rotor has a distinct advantage over other types of desiccant rotors in that dust and grease can be washed out of the material without the need for reimpregnation after treatment. In all normal applications however it must be emphasised that washing of the rotor should be considered as a last resort having alleviated all other possible defects first.

### Caution!

Please contact a DST-representative before attempting to wash the rotor!

# 11 TECHNICAL DATA

RLZ-81 RLZ-82 RLZ-101 RLZ-102 RLZ-102L RLZ-104

Capacity							
Capacity [kg/h]	<sup>1</sup>	19	25	30.5	49.5	57	70
Nominal dry air flow [m <sup>3</sup> /h]	<sup>2</sup>	2900	3500	4600	7000	10000	10500
External static pressure dry air [Pa]	<sup>2</sup>	300	300	300	300	300	300
Nominal wet air flow [m <sup>3</sup> /h]	<sup>2</sup>	750	1000	1300	2100	2400	2500
External static pressure wet air [Pa]	<sup>2</sup>	200	200	200	200	200	200
Regeneration heater - Electric							
Heater power [kW]		24	30	40	63	70	80
Number of electric heater steps		2	2	2	2	2	2
Heating power in steps [kW]		1/2 - 10,3 2/2 - 24	1/2 - 12,9 2/2 - 30	1/2 - 17,2 2/2 - 40	1/2 - 27 2/2 - 63	1/2 - 30 2/2 - 70	1/2 - 34,8 2/2 - 80
Heating power with linear control [kW]	<sup>4</sup>	0-24	0-30	0-40	0-63	0-70	0-80
Total power - Electrical							
Total motor power [kW]		3.6	4	3.6	7.4	9.7	11.5
Total power [kW]		27.6	34	43.6	70.4	79.7	91.5
Other electrical information							
Supply fuse 3x400V/50Hz [A]		50	63	80	125	125	160
Electric compartment protection class		IP54	IP54	IP54	IP54	IP54	IP54
Humidistat connection		230VAC	230VAC	230VAC	230VAC	230VAC	230VAC
Humidistat supply current [A]	<sup>5</sup>	< 1	< 1	< 1	< 1	< 1	< 1
Temperature setpoint settings							
Overheat protection TH1 [°C]		190	190	190	190	190	190
Thermostat TH2 [°C]		160	160	160	160	160	160
Overheat protection TH3 [°C]		80	80	80	80	80	80
Temperature setpoint settings							
Max. process air inlet temperature [°C]		40	40	40	40	40	40
Max. operating temperature [°C]		50	50	50	50	50	50
Min. operating temperature [°C]		-20	-20	-20	-20	-20	-20
Other technical data							
Air filter class (regeneration/process)		G4/G4	G4/G4	G4/G4	G4/G4	G4/G4	G4/G4
Filter change at pressure (G4/F7) [Pa]	<sup>6</sup>	200/250	200/250	200/250	200/250	200/250	200/250
Airflow guard - Regeneration [Pa]		100	100	100	200	200	300
Noise level [dB(A)]	<sup>3</sup>	73	81	74	78	78	86
Regeneration air fan delay [min]		15	15	15	15	15	15
Weight [kg]		294	325	380	503	585	600

<sup>1</sup> Valid for inlet conditions 20 °C/ 60%RH (equal 1.2 kg/m<sup>3</sup>).

<sup>2</sup> If no data is stated here the volume flow above is given at free blowing airflow.

<sup>3</sup> Unit connected to uninsulated ducts. Nominal airflows.

<sup>4</sup> Applies for dehumidifiers with installed optional feature.

<sup>5</sup> The current provided by the humidistat connection. Only use humidistats that are capable of this load current.

<sup>6</sup> (EN779 = ISO16890) G4 = Coarse 60%, M5 = ePM10 60%, F7 = ePM1 60%, F9 = ePM1 85%

The content of in this document may be subject to change without prior notice. For questions and comments regarding the content in this document, please send it to

Seibu Giken DST AB, ATT: Documentation, Avestagatan 33, 163 53 SPÅNGA, SWEDEN.

E-mail: info@dst-sg.com, subject: Documentation.

# Component list RLZ-81/82/101/102/102L/104

Description	Type, Drwg No, etc:	81	82	101	102	102L	104	Qty	Art No:	Notes:
<b>Rotor unit</b>										
Rotor	DMR 770H10	<input checked="" type="checkbox"/>	<input type="checkbox"/>	<input type="checkbox"/>	<input type="checkbox"/>	<input type="checkbox"/>	<input type="checkbox"/>	1	108258	
Rotor	DMR 770H20	<input type="checkbox"/>	<input checked="" type="checkbox"/>	<input type="checkbox"/>	<input type="checkbox"/>	<input type="checkbox"/>	<input type="checkbox"/>	1	108259	
Rotor	DMR 965H10	<input type="checkbox"/>	<input type="checkbox"/>	<input checked="" type="checkbox"/>	<input type="checkbox"/>	<input type="checkbox"/>	<input type="checkbox"/>	1	108260	
Rotor	DMR 965H20	<input type="checkbox"/>	<input type="checkbox"/>	<input type="checkbox"/>	<input checked="" type="checkbox"/>	<input checked="" type="checkbox"/>	<input type="checkbox"/>	1	108261	
Rotor	DMR 965H40	<input type="checkbox"/>	<input type="checkbox"/>	<input type="checkbox"/>	<input type="checkbox"/>	<input type="checkbox"/>	<input checked="" type="checkbox"/>	1	108262	
Periferal seal	EPDM+Felt 3300x30	<input checked="" type="checkbox"/>	<input checked="" type="checkbox"/>	<input type="checkbox"/>	<input type="checkbox"/>	<input type="checkbox"/>	<input type="checkbox"/>	5m	103133	
Periferal seal	EPDM+Felt 3300x30	<input type="checkbox"/>	<input type="checkbox"/>	<input checked="" type="checkbox"/>	<input checked="" type="checkbox"/>	<input checked="" type="checkbox"/>	<input checked="" type="checkbox"/>	6.1m	103133	
Radial seal	Teflon seal A	<input type="checkbox"/>	<input type="checkbox"/>	<input checked="" type="checkbox"/>	<input checked="" type="checkbox"/>	<input checked="" type="checkbox"/>	<input checked="" type="checkbox"/>	2	DST09704	
Radial seal	Teflon seal B	<input type="checkbox"/>	<input type="checkbox"/>	<input checked="" type="checkbox"/>	<input checked="" type="checkbox"/>	<input checked="" type="checkbox"/>	<input checked="" type="checkbox"/>	2	DST09706	
Radial seal	Teflon seal C	<input type="checkbox"/>	<input type="checkbox"/>	<input checked="" type="checkbox"/>	<input checked="" type="checkbox"/>	<input checked="" type="checkbox"/>	<input checked="" type="checkbox"/>	2	DST09705	
Radial seal	Teflon seal A	<input checked="" type="checkbox"/>	<input checked="" type="checkbox"/>	<input type="checkbox"/>	<input type="checkbox"/>	<input type="checkbox"/>	<input type="checkbox"/>	2	DST09701	
Radial seal	Teflon seal B	<input checked="" type="checkbox"/>	<input checked="" type="checkbox"/>	<input type="checkbox"/>	<input type="checkbox"/>	<input type="checkbox"/>	<input type="checkbox"/>	2	DST09702	
Radial seal	Teflon seal C	<input checked="" type="checkbox"/>	<input checked="" type="checkbox"/>	<input type="checkbox"/>	<input type="checkbox"/>	<input type="checkbox"/>	<input type="checkbox"/>	2	DST09703	
Hose clamp	8mm Endless Band-ty:EB-L:2500 mm- Bandwidth:8mm-W2 EB208B	<input checked="" type="checkbox"/>	<input checked="" type="checkbox"/>	<input type="checkbox"/>	<input type="checkbox"/>	<input type="checkbox"/>	<input type="checkbox"/>	5m	112595	
Hose clamp	8mm Endless Band-ty:EB-L:2500 mm- Bandwidth:8mm-W2 EB208B	<input type="checkbox"/>	<input type="checkbox"/>	<input checked="" type="checkbox"/>	<input checked="" type="checkbox"/>	<input checked="" type="checkbox"/>	<input checked="" type="checkbox"/>	7m	112595	
Lock hose clamp		<input checked="" type="checkbox"/>	<input checked="" type="checkbox"/>	<input checked="" type="checkbox"/>	<input checked="" type="checkbox"/>	<input checked="" type="checkbox"/>	<input checked="" type="checkbox"/>	2	112596	
Friction list	EPDM 3110x30x0,8 mm	<input checked="" type="checkbox"/>	<input checked="" type="checkbox"/>	<input checked="" type="checkbox"/>	<input checked="" type="checkbox"/>	<input checked="" type="checkbox"/>	<input checked="" type="checkbox"/>	1	111358	
Rotormotor	A8M25DT 25W 230V50Hz	<input checked="" type="checkbox"/>	<input checked="" type="checkbox"/>	<input checked="" type="checkbox"/>	<input checked="" type="checkbox"/>	<input checked="" type="checkbox"/>	<input checked="" type="checkbox"/>	1	113739	
Gearhead	G8XH10 80 mm, ratio10	<input checked="" type="checkbox"/>	<input checked="" type="checkbox"/>	<input checked="" type="checkbox"/>	<input checked="" type="checkbox"/>	<input checked="" type="checkbox"/>	<input checked="" type="checkbox"/>	1	113740	
Gearhead	G860K 80 mm , ratio60	<input type="checkbox"/>	<input checked="" type="checkbox"/>	<input type="checkbox"/>	<input type="checkbox"/>	<input type="checkbox"/>	<input checked="" type="checkbox"/>	1	113741	
Gearhead	G836K 80 mm, ratio36	<input checked="" type="checkbox"/>	<input type="checkbox"/>	<input checked="" type="checkbox"/>	<input checked="" type="checkbox"/>	<input checked="" type="checkbox"/>	<input type="checkbox"/>	1	113742	
Belt tightener	Rulle R 11	<input checked="" type="checkbox"/>	<input checked="" type="checkbox"/>	<input checked="" type="checkbox"/>	<input checked="" type="checkbox"/>	<input checked="" type="checkbox"/>	<input checked="" type="checkbox"/>	1	101375	
Spring for belt tightener		<input checked="" type="checkbox"/>	<input checked="" type="checkbox"/>	<input checked="" type="checkbox"/>	<input checked="" type="checkbox"/>	<input checked="" type="checkbox"/>	<input checked="" type="checkbox"/>	2	111485	
Beltpulley	Z=19; DD=76.81	<input checked="" type="checkbox"/>	<input type="checkbox"/>	<input type="checkbox"/>	<input type="checkbox"/>	<input type="checkbox"/>	<input checked="" type="checkbox"/>	1	106458	
Beltpulley	Z=24; DD=97,02	<input type="checkbox"/>	<input type="checkbox"/>	<input checked="" type="checkbox"/>	<input checked="" type="checkbox"/>	<input checked="" type="checkbox"/>	<input type="checkbox"/>	1	106459	
Beltpulley	Z=16 DD=64.68	<input type="checkbox"/>	<input checked="" type="checkbox"/>	<input type="checkbox"/>	<input type="checkbox"/>	<input type="checkbox"/>	<input type="checkbox"/>	1	107323	
Belt	H-1325; l=3365; b=19.1mm	<input type="checkbox"/>	<input type="checkbox"/>	<input checked="" type="checkbox"/>	<input checked="" type="checkbox"/>	<input checked="" type="checkbox"/>	<input checked="" type="checkbox"/>	1	106457	
Belt	L=2794; B=19.1; Type 075	<input checked="" type="checkbox"/>	<input checked="" type="checkbox"/>	<input type="checkbox"/>	<input type="checkbox"/>	<input type="checkbox"/>	<input type="checkbox"/>	1	106456	
<b>Fans</b>										
Process fan	RHAC-31C DC 2.5kW	<input checked="" type="checkbox"/>	<input type="checkbox"/>	<input type="checkbox"/>	<input type="checkbox"/>	<input type="checkbox"/>	<input type="checkbox"/>	1	110454	
Process fan	RHAC-35C DC 2.5 kW	<input type="checkbox"/>	<input checked="" type="checkbox"/>	<input checked="" type="checkbox"/>	<input type="checkbox"/>	<input type="checkbox"/>	<input type="checkbox"/>	1	110455	
Process fan	RHAC-45C GG 5.2kW	<input type="checkbox"/>	<input type="checkbox"/>	<input type="checkbox"/>	<input checked="" type="checkbox"/>	<input type="checkbox"/>	<input type="checkbox"/>	1	110457	
Process fan	RHAD-50C 7,5kW 3x400V	<input type="checkbox"/>	<input type="checkbox"/>	<input type="checkbox"/>	<input type="checkbox"/>	<input checked="" type="checkbox"/>	<input checked="" type="checkbox"/>	1	110458	
Reg.fan	RHAD-28C 1,1 kW 3x400V	<input checked="" type="checkbox"/>	<input type="checkbox"/>	<input checked="" type="checkbox"/>	<input type="checkbox"/>	<input type="checkbox"/>	<input type="checkbox"/>	1	110450	
Reg.fan	RHAD-28C 1,5 kW 3x400V	<input type="checkbox"/>	<input checked="" type="checkbox"/>	<input type="checkbox"/>	<input type="checkbox"/>	<input type="checkbox"/>	<input type="checkbox"/>	1	110451	
Reg.fan	RHAD-28C 2,2 kW 3x400V	<input type="checkbox"/>	<input type="checkbox"/>	<input type="checkbox"/>	<input checked="" type="checkbox"/>	<input checked="" type="checkbox"/>	<input type="checkbox"/>	1	110452	
Reg.fan	RHAD-31C 4 kW 3x400V	<input type="checkbox"/>	<input type="checkbox"/>	<input type="checkbox"/>	<input type="checkbox"/>	<input type="checkbox"/>	<input checked="" type="checkbox"/>	1	110453	
<b>Filter</b>										
Filter Process	HCSS 592x592x360 G4	<input type="checkbox"/>	<input type="checkbox"/>	<input checked="" type="checkbox"/>	<input checked="" type="checkbox"/>	<input checked="" type="checkbox"/>	<input checked="" type="checkbox"/>	2	100687	
Filter Process	HCSS 892X490X360 G4	<input checked="" type="checkbox"/>	<input checked="" type="checkbox"/>	<input type="checkbox"/>	<input type="checkbox"/>	<input type="checkbox"/>	<input type="checkbox"/>	1	100900	
Filter Regeneration	HCSS 592x287x360 G4	<input checked="" type="checkbox"/>	<input checked="" type="checkbox"/>	<input type="checkbox"/>	<input type="checkbox"/>	<input type="checkbox"/>	<input type="checkbox"/>	1	104351	
Filter Regeneration	HCSS 592x490x360G4	<input type="checkbox"/>	<input type="checkbox"/>	<input checked="" type="checkbox"/>	<input checked="" type="checkbox"/>	<input checked="" type="checkbox"/>	<input checked="" type="checkbox"/>	1	105316	
<b>Regeneration heater - Resistive heater</b>										
Reg. heater	24kW; 3x400V	<input checked="" type="checkbox"/>	<input type="checkbox"/>	<input type="checkbox"/>	<input type="checkbox"/>	<input type="checkbox"/>	<input type="checkbox"/>	1	106355	
Reg. heater	30kW; 3x400V	<input type="checkbox"/>	<input checked="" type="checkbox"/>	<input type="checkbox"/>	<input type="checkbox"/>	<input type="checkbox"/>	<input type="checkbox"/>	1	108787	
Reg. heater	40kW; 3x400V	<input type="checkbox"/>	<input type="checkbox"/>	<input checked="" type="checkbox"/>	<input type="checkbox"/>	<input type="checkbox"/>	<input type="checkbox"/>	1	106356	
Reg. heater	63kW; 3x400V	<input type="checkbox"/>	<input type="checkbox"/>	<input type="checkbox"/>	<input checked="" type="checkbox"/>	<input type="checkbox"/>	<input type="checkbox"/>	1	106357	
Reg. heater	70 kW; 3x400V	<input type="checkbox"/>	<input type="checkbox"/>	<input type="checkbox"/>	<input type="checkbox"/>	<input checked="" type="checkbox"/>	<input type="checkbox"/>	1	111361	
Reg. heater	80kW; 3x400V	<input type="checkbox"/>	<input type="checkbox"/>	<input type="checkbox"/>	<input type="checkbox"/>	<input type="checkbox"/>	<input checked="" type="checkbox"/>	1	108765	
<b>Other</b>										
Electric box		<input checked="" type="checkbox"/>	<input checked="" type="checkbox"/>	<input checked="" type="checkbox"/>	<input checked="" type="checkbox"/>	<input checked="" type="checkbox"/>	<input checked="" type="checkbox"/>	1	-	

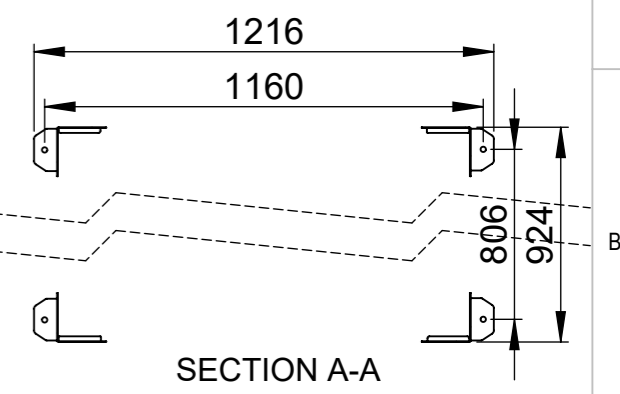
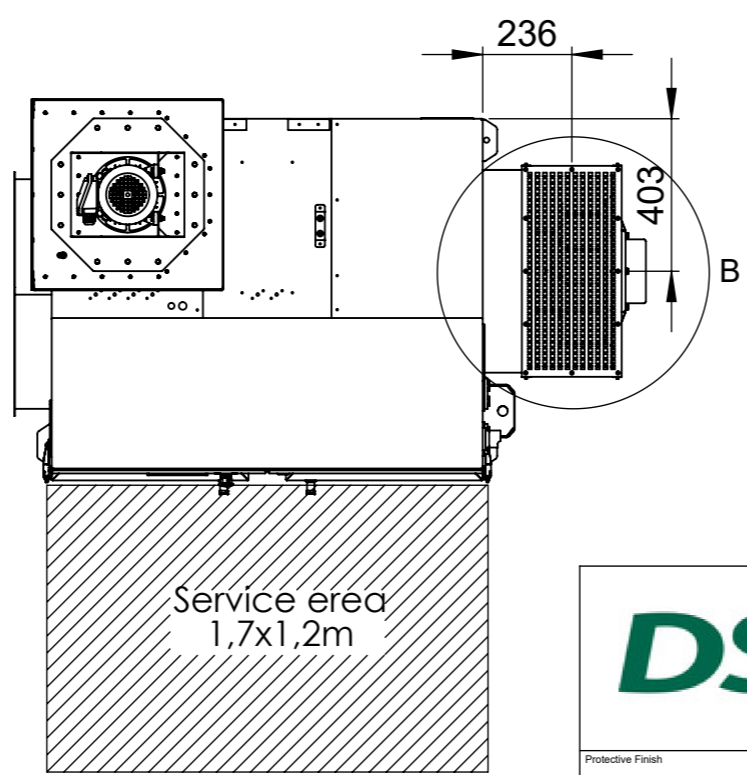
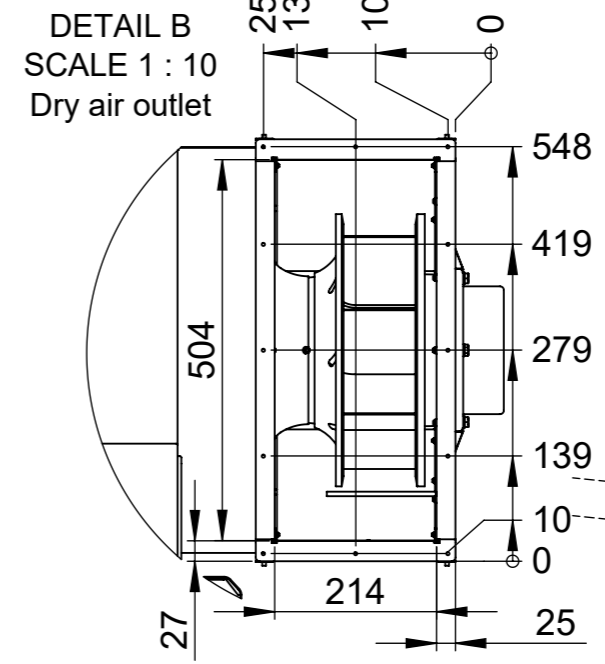
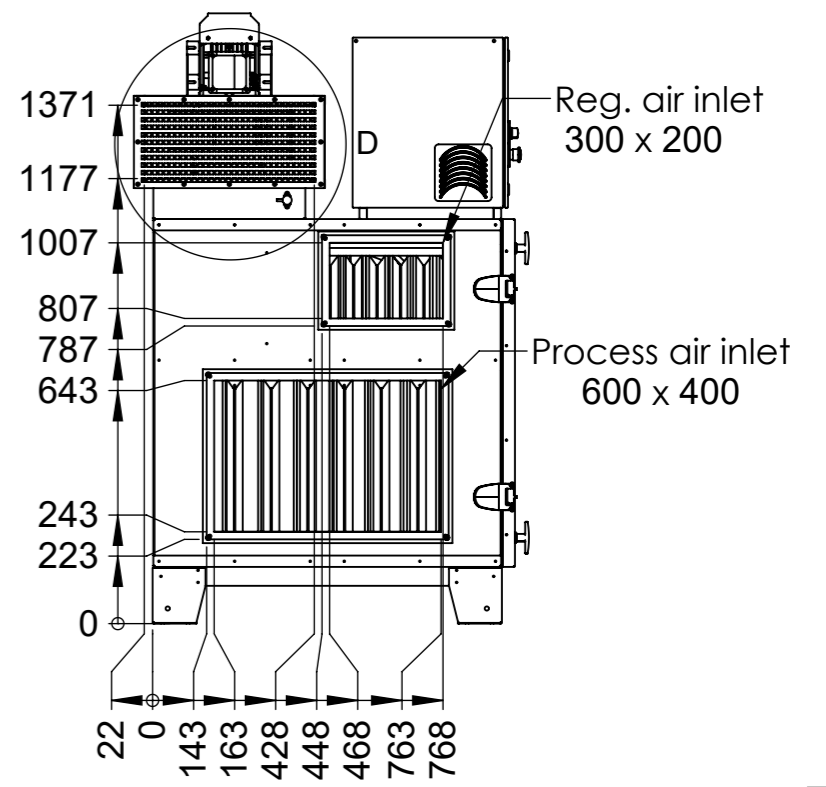
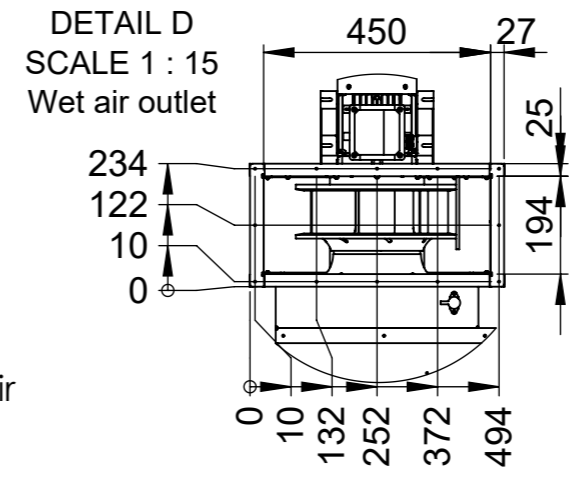
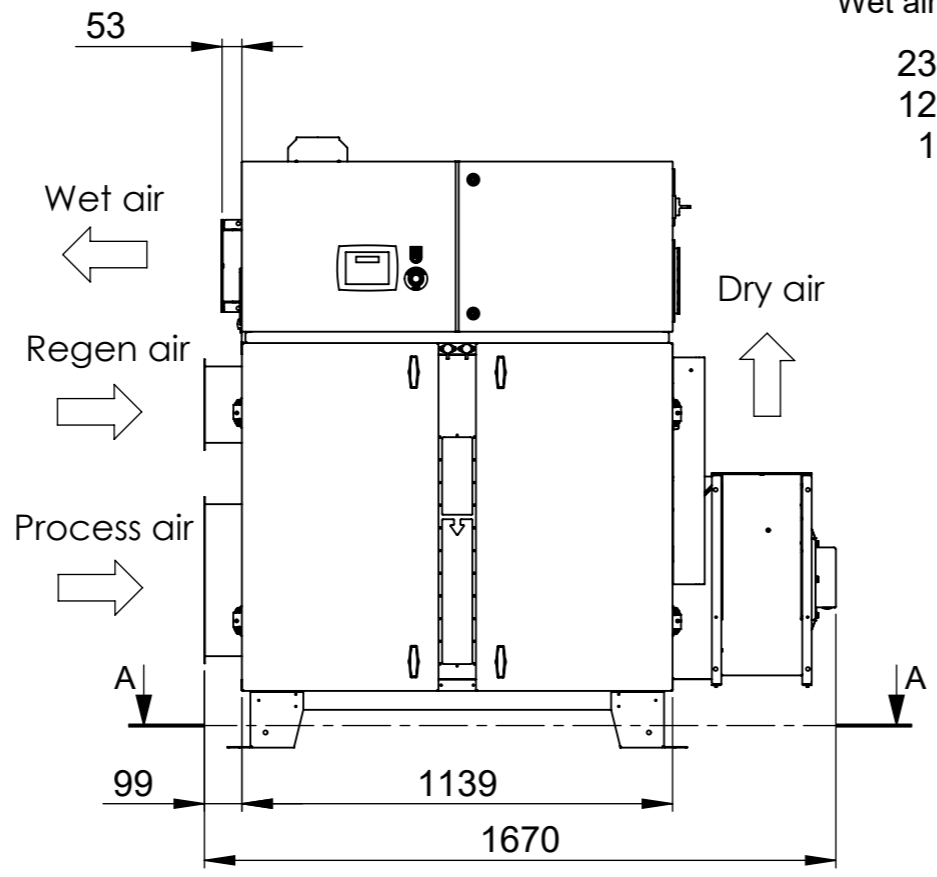
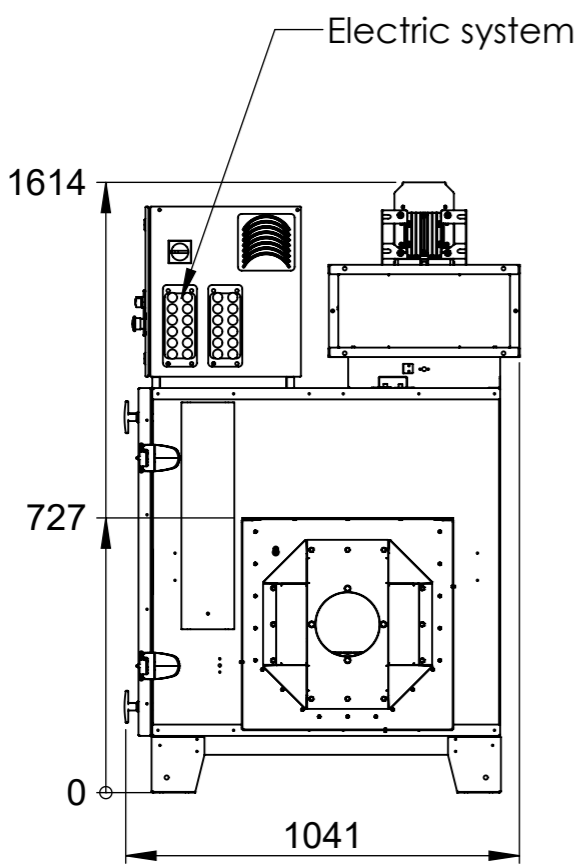

This document and its contents are the exclusive property of DST Seibu Giken and must not be copied, reproduced, transmitted or communicated to any other party or used for purposes not expressly permitted by us.

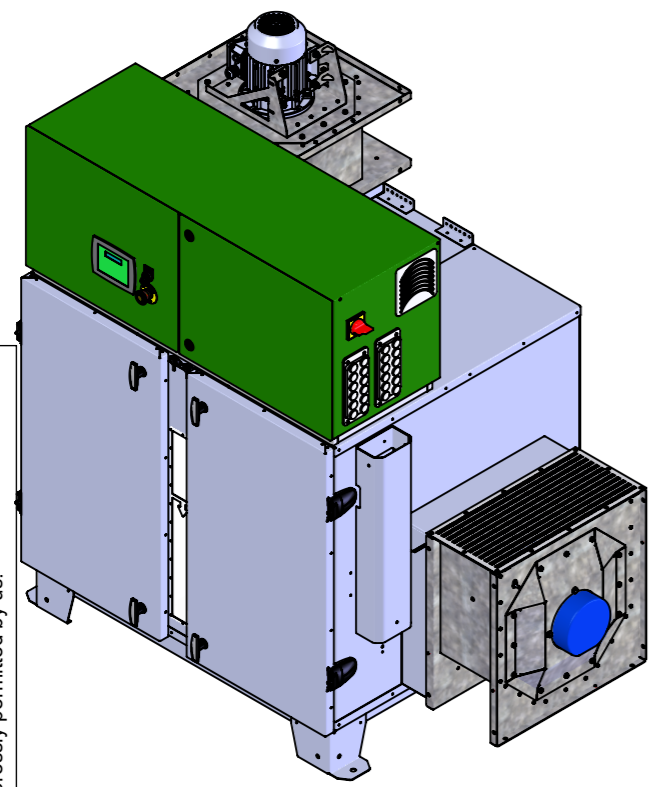

	Designed by	Aynur Polat	Date	2018-02-19	Title/Description	Installation drawing RLZ-81R	
	Drawn by	Aynur Polat	Date	2018-06-26		<b>RLZ-81</b>	
	Approved by	EL	Date	2024-01-25	Drawing no	<b>DST09924</b>	
	Protective Finish		Material		Thickness	t=	
Seibu Giken DST AB +46 8 445 77 20 www.dst-sg.com	Status	Approved		Tolerance	Rev <b>05</b>	Rev <b>05</b>	
	Scale	Format	Sheet/Sheet	Rev Part		Weight (Kg)	Rev <b>05</b>
	1:20	A3	1/1	05	294.000		



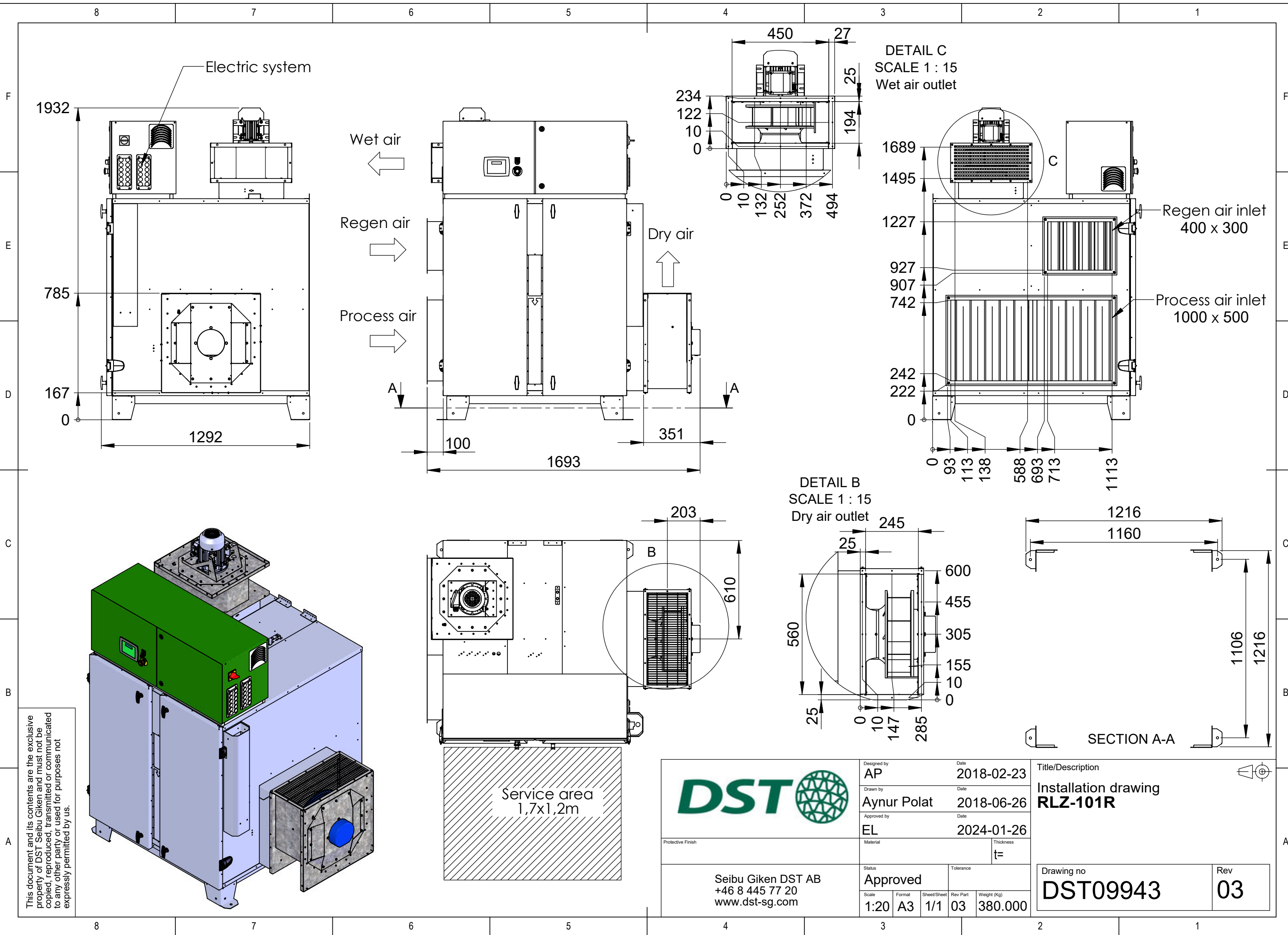

This document and its contents are the exclusive property of DST Seibu Giken and must not be copied, reproduced, transmitted or communicated to any other party or used for purposes not expressly permitted by us.

	Designed by	AP	Date	2018-02-23	Title/Description <b>Installation drawing          RLZ-101R</b>
	Drawn by	Aynur Polat	Date	2018-06-26	
	Approved by	EL	Date	2024-01-26	Drawing no <b>DST09943</b>
Protective Finish	Material	Thickness	t=		
Seibu Giken DST AB +46 8 445 77 20 www.dst-sg.com	Status	Approved		Tolerance	Rev <b>03</b>
	Scale	Format	Sheet/Sheet	Rev Part	
	1:20	A3	1/1	03	380.000

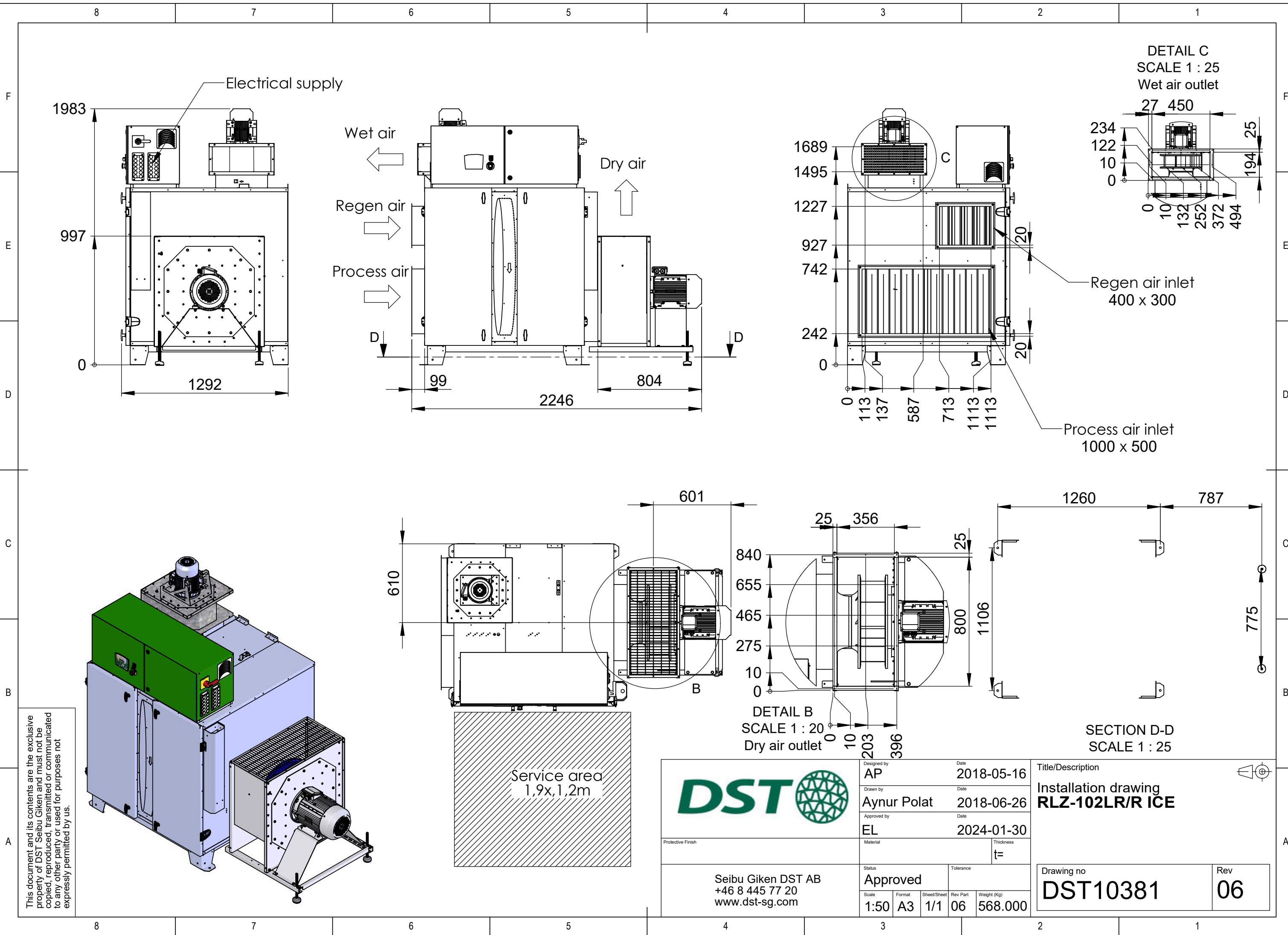

This document and its contents are the exclusive property of DST Seibu Giken and must not be copied, reproduced, transmitted or communicated to any other party or used for purposes not expressly permitted by us.

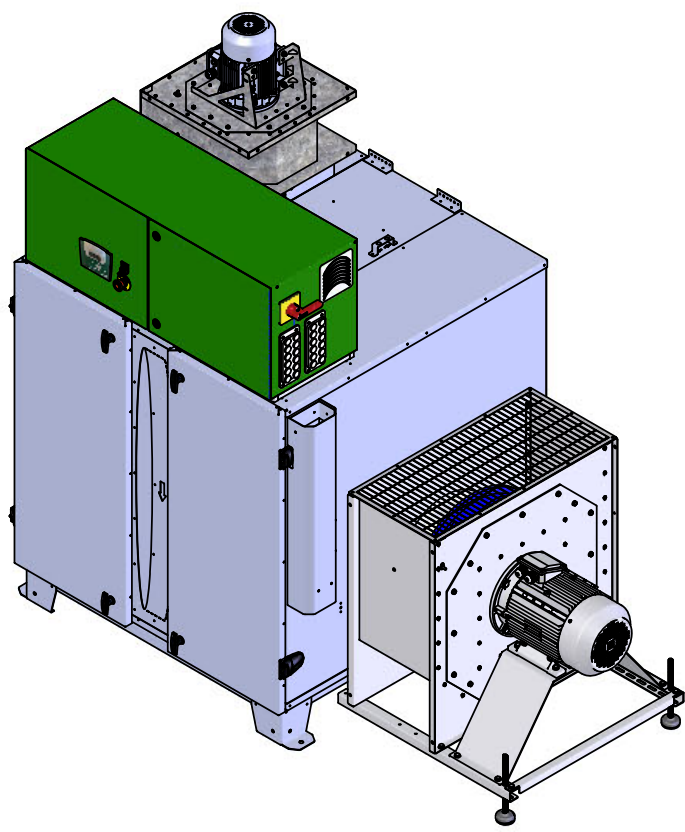

	Designed by <b>AP</b>	Date 2018-05-16	Title/Description <b>Installation drawing RLZ-102LR/R ICE</b>
	Drawn by <b>Aynur Polat</b>	Date 2018-06-26	
	Approved by <b>EL</b>	Date 2024-01-30	Drawing no <b>DST10381</b>
Protective Finish	Material	Thickness t=	
Seibu Giken DST AB +46 8 445 77 20 www.dst-sg.com		Status <b>Approved</b>	Tolerance
Scale 1:50	Format A3	Sheet/Sheet 1/1	Rev Part 06
		Weight (Kg) 568.000	

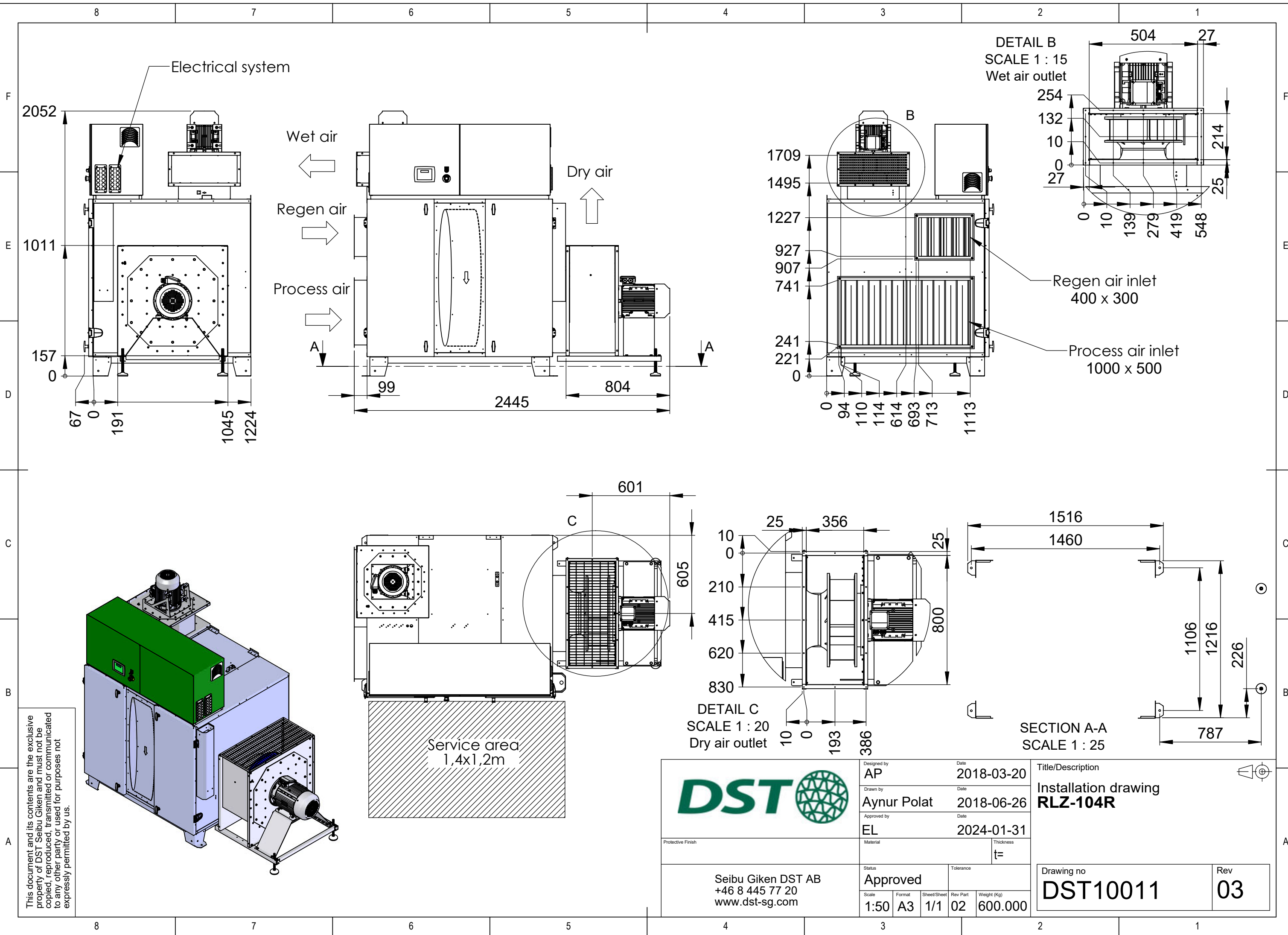

This document and its contents are the exclusive property of DST Seibu Giken and must not be copied, reproduced, transmitted or communicated to any other party or used for purposes not expressly permitted by us.

	Designed by AP	Date 2018-03-20	Title/Description <b>Installation drawing RLZ-104R</b>
	Drawn by Aynur Polat	Date 2018-06-26	
	Approved by EL	Date 2024-01-31	Drawing no <b>DST10011</b>
Protective Finish	Material	Thickness t=	
Seibu Giken DST AB +46 8 445 77 20 www.dst-sg.com	Status Approved	Tolerance	Rev <b>03</b>
	Scale 1:50	Format A3	
	Rev Part 02	Weight (Kg) 600.000	

# QUICK GUIDE

## Change parameter on Danfoss FC-101



World leaders in dehumidification

### CONTROL PANEL OVERVIEW

1. Parameter number and name.
2. Parameter value
3. **[Menu]** - Key for selecting the status menu, quick menu or main menu
4. The triangle indicates if the VSD is in Status, Quick Menu or Main Menu
5. **[Back]**: Returns to the previous step or level
6. **[▲]/[▼]/[▲]** - Navigation between parameters and for changing parameters or local references
7. **[OK]** - Selecting parameters and saving set values
8. **[Hand/On]** - Starting the motor for local control using the control unit
9. **[Off/Reset]** - Stopping the motor and resetting alarms.
10. **[Auto/On]** - Allow control via control terminals or the communication bus

**Note:** If the unit is fitted with a frequency converter from factory, use the supplied parameter list in the user's manual for reference when reverting back original settings. If the unit is retrofitted with a frequency converter, the parameter list is supplied separately and is not included in the user's manual.

**Note:** To change parameter during operation, turn off the unit using the PLC, or press **[Off/Reset]** on the VSD. To start the fan with the new parameters, press **[Auto/On]**.

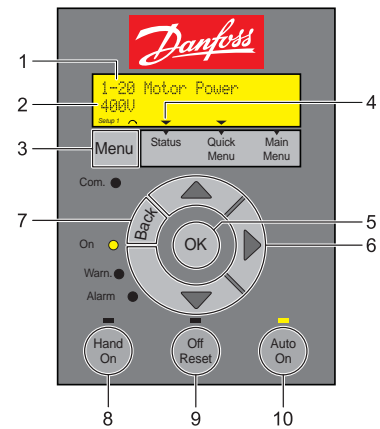

#### Main Menu - accesses all parameters

The "Main Menu" has all the parameter needed to adjust the VSD. To access the most common parameters according to the parameter table, use the "Quick Menu". See right.

1. Press the **[Menu]** key until the indicator (4) in the display is placed above "Main Menu".

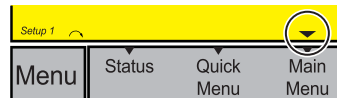

2. Press **[▲]/[▼]** to browse through the parameter groups, then press **[OK]** to select the group.



3. Press **[▲]/[▼]** to browse through the parameters in sub-group, then press **[OK]** to select the sub-group.



4. Press **[▲]/[▼]** to select the specific parameter, then press **[OK]** to highlight the value.

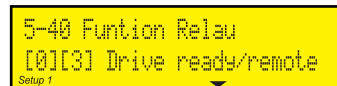

4. Press **[▲]/[▼]** to change the value of a parameter setting, then press **[OK]** to accept the change.

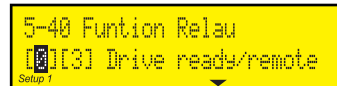

5. Press **[Back]** twice to exit.

#### Quick Menu - Selected parameters only\*

1. Press the **[Menu]** key to enter the "Quick Menu" until the indicator (4) in the display is placed above "Quick Menu".

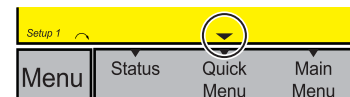

2. Press **[▲]/[▼]** to select the "FC-101 Wizard", then press **[OK]** to open the wizard.



3. Press **[▲]/[▼]** to browse through the parameters in the quick menu.

4. Press **[OK]** to select a parameter.



5. Press **[▲]/[▼]** to change the value of a parameter setting, then press **[OK]** to accept the change.

6. Press either **[Back]** twice to exit.

\*Not all parameters are accessible through "Quick Menu", see parameter table.

Parameter	Quick Menu / Main Menu
1-20 Motor Power	Yes / Yes
1-22 Motor Voltage	Yes / Yes
1-23 Motor Frequency	Yes / Yes
1-24 Motor Current	Yes / Yes
1-25 Motor Nominal Speed	Yes / Yes
3-02 Minimum Reference	Yes / Yes
3-03 Maximum Reference	Yes / Yes
3-41 Ramp 1 Ramp Up Time*	Yes / Yes
3-42 Ramp 1 Ramp Down Time**	Yes / Yes
5-40 Function Relay*	No / Yes

\*Acceleration time, \*\* Deacceleration time

#### View operational data

To display data during operation. Ensure the indicator (4) is positioned above "Status". If not, press **[Main Menu]** and then press **[▲]/[▼]** to cycle the displays.



**Note:** For more details, troubleshooting and other instructions, see Danfoss FC-101 user's manual. Provided separately upon delivery of the unit or online at <http://www.danfoss.com>.

## Parameter list / Parameter lista

### Regeneration fan

Par no:	Quick setup	RLZ-81	RLZ-82	RLZ-101	RLZ-102	RLZ-102L	RLZ-104
1.22	Motor Nom voltage	400V	400V	400V	400V	400V	400V
1.23	Motor Nom frequency	50Hz	50Hz	50Hz	50Hz	50Hz	50Hz
1.25	Motor Nom speed	2900rpm	2900rpm	2900rpm	2910rpm	2910rpm	2920rpm
1.24	Motor Nom current	2,34A	3,14A	2,34A	4,40A	4,40A	7,20A
1.20	Motor Nom power	1,1kW	1,5kW	1,1kW	2,2kW	2,2kW	4kW
3.02	Min frequency reference	47Hz	63Hz	54Hz	67Hz	67Hz	71Hz
3.03	Max frequency reference	62Hz	68Hz	62Hz	76Hz	76Hz	72Hz
3.41	Acceleration time	20sek	20sek	20sek	20sek	20sek	20sek
3.42	Deceleration time	30sek	30sek	30sek	30sek	30sek	30sek
4.12	Motor speed low limit	47Hz	63Hz	54Hz	67Hz	72Hz	71Hz
4.14	Motor speed high limit	62Hz	68Hz	62Hz	76Hz	76Hz	72Hz
5.40	Relay output	(0) (3)	(0) (3)	(0) (3)	(0) (3)	(0) (3)	(0) (3)

### Process fan

Par no:	Quick setup	RLZ-102ICE	RLZ-102L	RLZ-104
1.20	Motor Nom power	7,5kW	7,5kW	7,5kW
1.22	Motor Nom voltage	400V	400V	400V
1.23	Motor Nom frequency	50Hz	50Hz	50Hz
1.24	Motor Nom current	14,3A	14,3A	14,3A
1.25	Motor Nom speed	1460rpm	1460rpm	1460rpm
3.02	Min reference	0	0	0
3.03	Max reference	100	100	100
3.41	Acceleration time	30sek	30sek	30sek
3.42	Deceleration time	40sek	40sek	40sek
4.12	Motor speed low limit	0Hz	0Hz	0Hz
4.14	Motor speed high limit	83Hz	73Hz	83Hz
5.40	Relay output	(0) (3)	(0) (3)	(0) (3)
6.14	Term 53 low reference	0	0	0

## Harmful chemicals and solvents for rotors

SEIBU GIKEN CO.,LTD.

Reduced performance and/or rotor degradation is possible when adsorping the following substances.

	Substance	Note	Chemical formula	Cause
1	Oil vapor		N/A	Clogs the micro pores on the silica gel/zeolite.
2	Ammonia	2ppm and above, prolonged exposure	NH <sub>3</sub>	Degrades the silica gel/zeolite.
3	Amine		RNH <sub>2</sub>	
4	Hydrogen fluoride		HF	Corrodes the silica gel/zeolite.
5	Sodium hydroxide	High concentration	NaOH	Dissolves the silica gel/zeolite.
6	Potassium hydrate	High concentration	KOH	Clogs the micro pores on the silica gel/zeolite.
7	Lithium chloride		LiCl	
8	Sodium chloride		NaCl	
9	Potassium chloride		KCl	
10	Calcium chloride		CaCl <sub>2</sub>	
11	Magnesium chloride		MgCl <sub>2</sub>	
12	Aluminum chloride		AlCl <sub>3</sub>	
13	Seawater		N/A	
14	Strong acid	pH=3 and below	N/A	Deteriorates the honeycomb's physical structure.
15	Plasticizer		N/A	Clogs the micro pores on the silica gel/zeolite.
16	Nitrogen oxides	High concentration, excessive exposure	NO <sub>x</sub>	Deteriorates the honeycomb's physical structure.
17	Sulfur oxides	High concentration, excessive exposure	SO <sub>x</sub>	
18	High-temperature steam	Exposod to vapor of 100 and above.	N/A	Cracks occurs on the honyecomb.
19	Heat solubility dust		N/A	Dust covers the silica gel/zeolite surface.

There is no guarantee that other substances beyond this list may reduce the dehumidification performance or damage the silica gel/zeolite.

# Declaration of conformity and incorporation for CE & UKCA

As of 2022, the latest declaration of conformity for fully assembled machinery and declaration of incorporation of partly assembled machinery for CE and UKCA are available for downloads.

Scan the follow QR-code to access all types of certificates via a phone or tablet.



If unable to scan the QR-code, visit DST website at:

**<https://www.dst-sg.com/certificates/>**

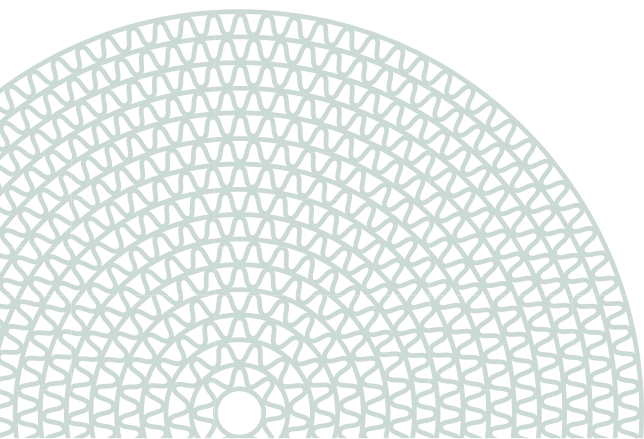







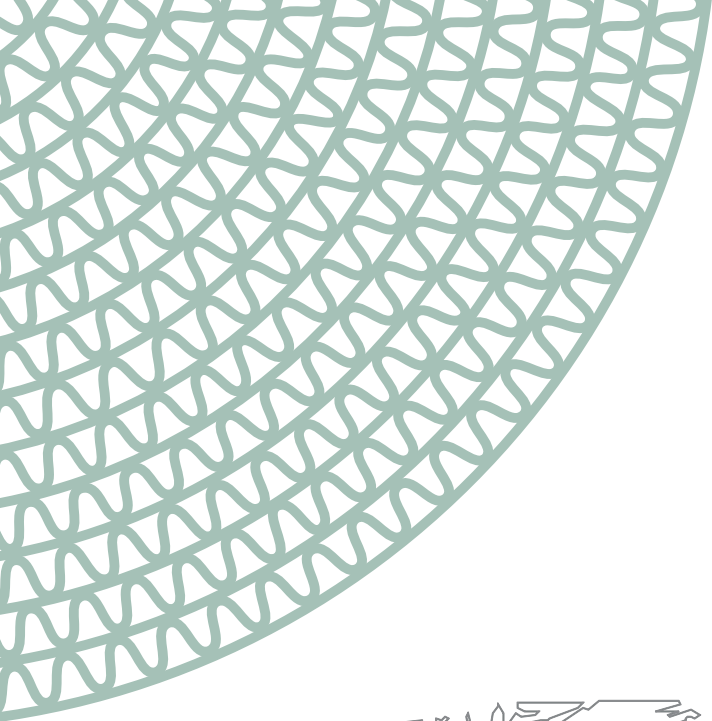

Seibu Giken DST AB  
Avestagatan 33 | 163 53 Spånga, Sweden

---

Phone: +46 8 445 77 20 | Fax: +46 8 445 77 39  
info@dst-sg.com | www.dst-sg.com



Seibu Giken DST is certified  
according to ISO 9001