



**HERON**  
TECH

# FLUSH SELF-PIERCE RIVETING TECHNOLOGY

---

HT FSPR®: Riveting Solutions For High-Strength  
Performance & Lightweighting Applications

Innovative Joining

**Welding | Clinching | Riveting | Industry 4.0**

# About Heron Tech

We are Heron Technologies USA Inc., an exciting spinoff from the highly respected Heron Group, a leader in modern industrial technology. Building on our legacy of innovation and excellence, we are dedicated to shaping the future of manufacturing with high-tech industrial components & consumables, paired with Heron-engineered industrial equipment.

Our mission is simple: To help industry partners accelerate the transition to green and intelligent manufacturing with innovative products & solutions by Heron.

## COMPANY TIMELINE

### 45+ Years

#### AKH over the years

1981-1990



1990 -2022



2023 - present



### 2+ Years

#### HERON over the years

2025



Partnering with Heron since 2019, AKH continues to innovate and maintains a strong commitment to excellence, customer satisfaction and innovation in rivet manufacturing.

After our rebrand in 2025, Heron Tech (HT) aims to become a trusted leader in the metal joining industry by serving a wide range of industries and providing reliable solutions that meet the demanding standards of modern manufacturing.

## Flush Self-Pierce Riveting Technology

FSPR® or Flush-self pierce riveting technology is a mechanical joining technique for identical or dissimilar materials, allowing the joining of two or more layers of varying thicknesses, pre-painted or pre-coated; no pre-drilling required.



### Technical Principle

The FSPR® self-pierce riveting process is realized by a simple punch and die operation which automatically feeds, punches, inserts and locks the self-piercing rivet to produce a solid join in one high-cycle operation. The three steps are as follows:

Step 1

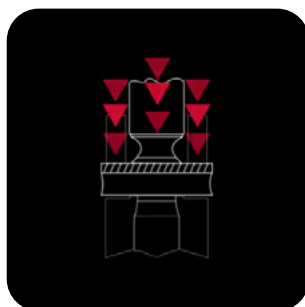

**STAMPING**

Step 2

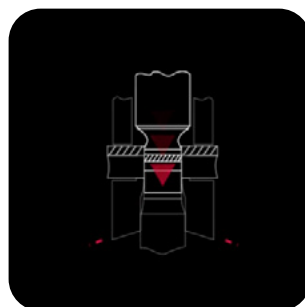

**PIERCING**

Step 3

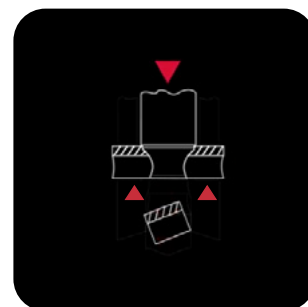

**FORMING**

## An innovative solution for special materials

Across modern manufacturing sectors—automotive or general industry —production increasingly relies on advanced riveting solutions. As a robust and time-tested joining method, HT's FSPR® delivers permanent, high-integrity joining between metal components. Unlike threaded fasteners, rivets require no pre-drilled holes and thus eliminate risks of loosening, wear, or stripping. And in contrast to traditional joining methods, FSPR® enables the reliable joining of dissimilar or non-weldable materials.

For large-volume manufacturing pierce-based riveting processes without pre-drilled holes are standard. In these applications, the rivet punches through the material stack and forms its mechanical interlock in a single operation.

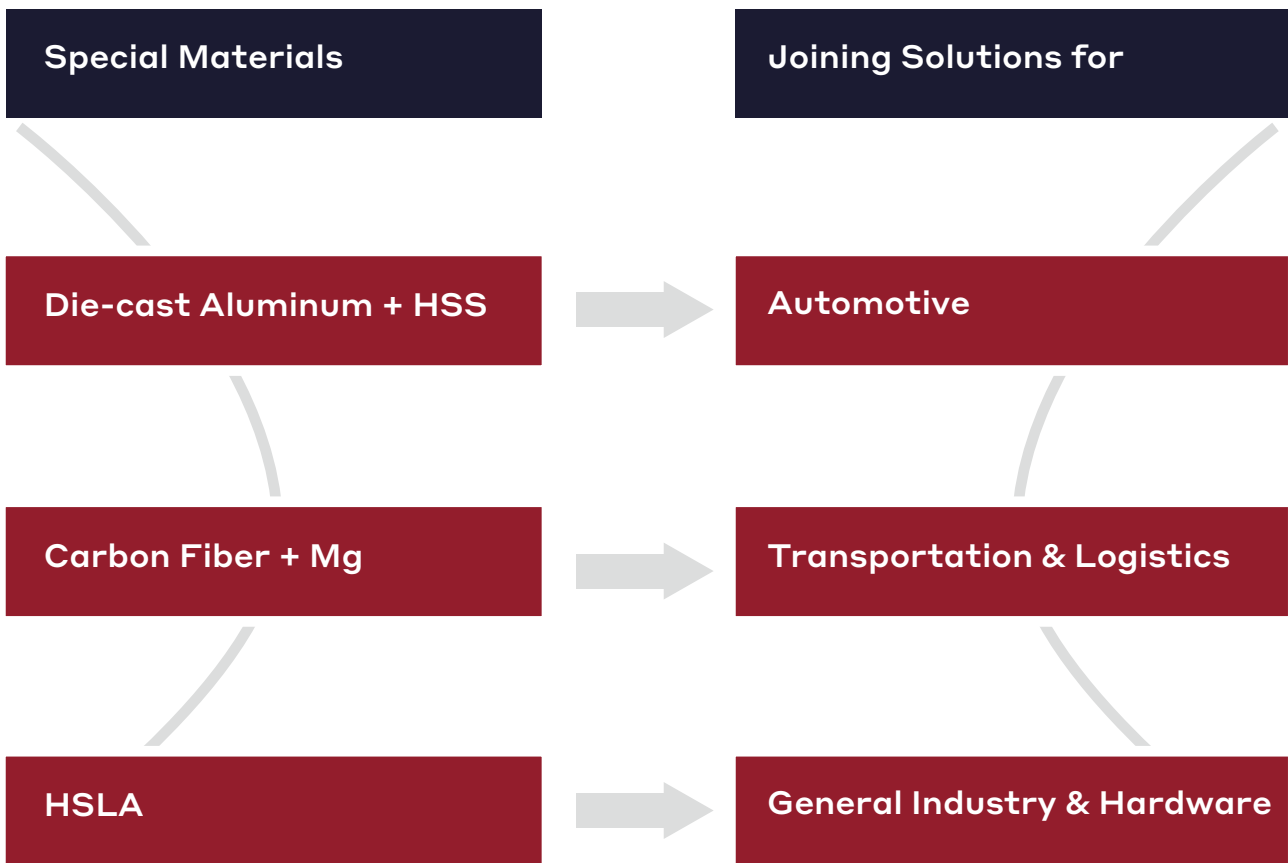

# Applicable Riveting Materials



## Deep drawing steels

with rm up to  
1000 mPa



## High-strength steels

with rm up to  
1600 mPa



## Hot-stamped steels

with rm up to  
1800 mPa

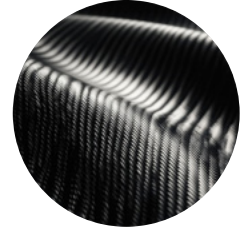

## Non-ferrous metals & non-metallic materials

(copper, mag.,  
and carbon fiber)  
as a middle layer



## Aluminium and alloy

(pressure cast,  
extruded, sheet)



## Multilayer stack-ups

with  
dissimilar materials

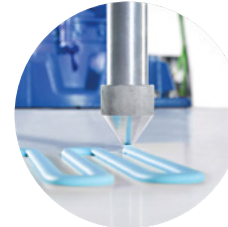

## Adhesive

applied as a  
middle layer



# Sample Combinations

## FSPR®

### The Optimal Riveting Technology for Lightweight Vehicles

#### ▲ Make Material Joining Simple

Enables joining of Al alloys, HSS (High-Strength Steel), and UHSS (Ultra-High-Strength Steel), while being compatible with heterogeneous combinations like CFRP (Carbon Fiber Reinforced Polymer), cast Al and cast Mg, breaking the bottleneck in lightweight material joining.

#### ▲ Make Vehicle-Design Flexible

Supports riveting of 2-4 material layers, suitable for complex multi-layer structures such as body frames and battery packs.

#### ▲ Make Quality Reliable

Adapts to a stacked thickness of 2.6-8.0mm, ensuring stable joining from thin materials to thick materials for axles and girders.

Material	Stack-ups Thickness/ mm	Max. Layer	Max. Shear Strength/ KN	Max. Pull strength/ KN
Al(+Cast Al)	4.2-8.0	3	19	5
Cast Al +HSS	4.35-4.8	3	7	3.6
Al+HSS/UHSS	3.2-5.2	4	9	11
Al+Cast Mg	3.9-6.0	3	10	4
Cast Al+ Galvanized Steel	3.65-5.1	3	7	2.5
Cast Mg(+Steel)	3.7-5.0	2	3	1.6
Carbon Fiber	2.6	2	1	0.3

## Recommended material stack-up

✓ Bottom plate thickness  $\geq 1/5$  of combined plate total thickness.

### Convex side:

High-strength metals (plated steel, hot-formed steel, high-strength steel, etc.)

### Middle layer:

Medium/low-strength metals & non-metals (carbon fiber, medium/low-strength steel, aluminum alloy, etc.)

### Concave side:

Medium/low-strength metals (medium/low-strength steel, aluminum alloy, etc.)

### 1 Two-layer riveting:

- Convex side material allows pull strength  $\leq 1800\text{mPa}$
- Concave side material allows pull strength  $\leq 1000\text{mPa}$

### 2 Multi-layer riveting:

Concave side material pull strength & Middle layer material pull strength  $\leq 250\text{MPa}$

- Positive difference: Concave material harder than middle layer
- Negative difference: Concave material softer than middle layer

Thin plate on punch side + thick plate on concave side = better riveting strength, but thick plate on punch side is allowed.



# FSPR: High joint integrity. Fatigue resistant.

Preferred process for mixed-material bodies, lightweight architectures, and optimized structural designs.

Cross Section

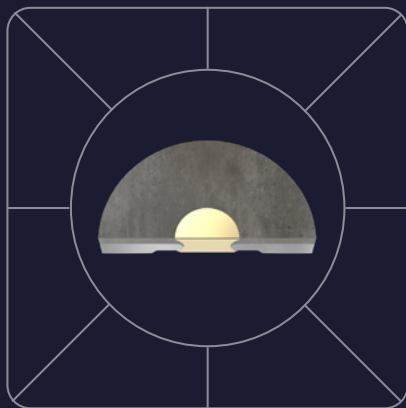
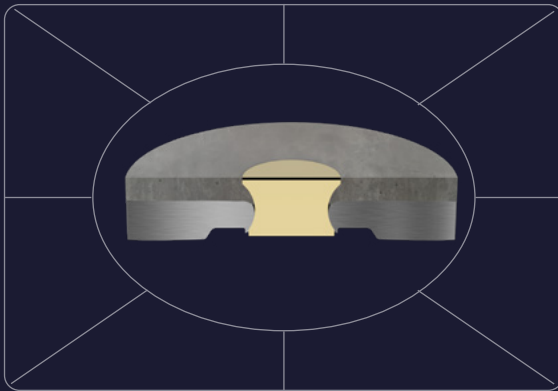

Punch Side

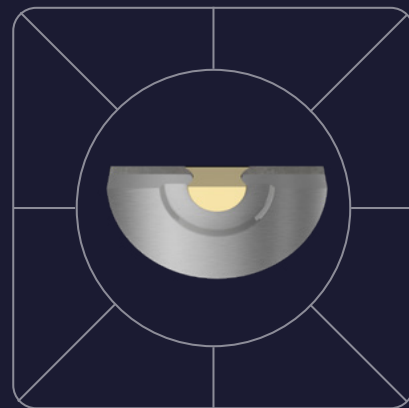

Die Side

# Why use our FSPR System?

## Quality

- Reliable industry-trusted joining method for 40+ years
- Joins up to 7 layers
- Works across steel, aluminum, copper, brass, magnesium,
- HSS and die-cast aluminum

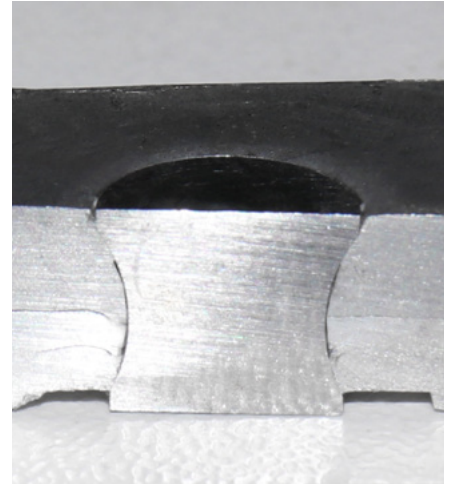

## Efficiency

- No pre-punched or drilled holes required
- Less handling, faster prep
- Fully compatible with automated production lines



## New Design = Cost Savings

- Optimized rivet magazine reduces feed travel and minimizes downtime
- Re-engineered tooling for multiple rivet sizes
- Enhanced quality monitoring for joint integrity



# FSPR Rivet Selection

The FSPR rivet is made from hardened steel or aluminum and available in a range of standard sizes.

The typical rivet shape is shown. For accurate selection and customization of rivets, please consult HERON.

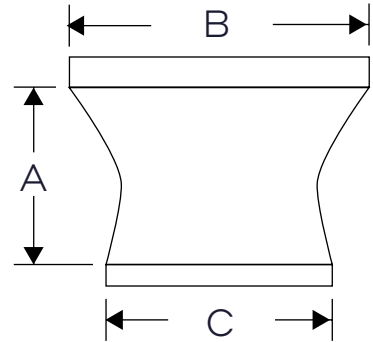

## RIVET SIZES

	01	02	03	04	05	06	07	08	09	10	11	12
A	1.9 mm	2.1 mm	2.5 mm	2.8 mm	3.2 mm	3.5 mm	3.9 mm	4.2 mm	4.6 mm	5 mm	5.1-9.1 mm	5.5-8.1 mm
B	5.3 mm							7.1 mm				7.6 mm
C	4.7 mm							6.3 mm				7.9 mm

## Style of Rivets

HT Rivets are available in a range of twelve standard sizes, across three styles – Headed (H), Double-Headed (DH) and Headed Painted (HP) Series.

The rivet geometry supports reliable performance in multi-layer stacks, while offering options for color customization and enhanced corrosion resistance.



### **H SERIES** **Headed Rivet**

A new rivet that enables consistent joint quality in multiple layers of die-cast materials & high-strength steel

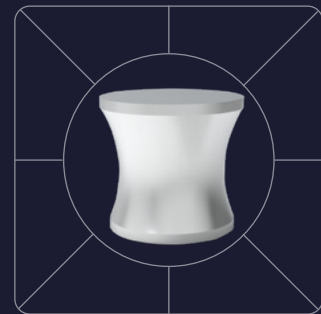

### **DH SERIES** **Double-Headed Rivet**

Designed for ultra-secure joints in applications requiring extra grip or visual balance on both sides of a material



### **HP SERIES** **Headed-Painted Rivet**

Pre-painted rivets offering structural integrity and visual appeal for exterior panels & painted assemblies

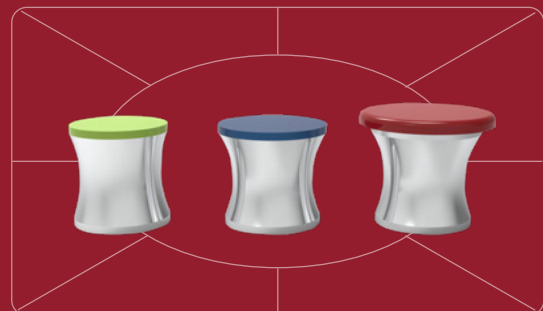

# Robot Riveting Unit

## Main Features

The Actuator housing of the ZM6 servo riveting system follows a lightweight design and includes a strain gauge force transducer with an integrated amplifier circuit board. Press fitting is carried out by a servo motor driving a threaded screw via a belt and gearbox. The encoder for precise positioning is integrated in the drive motor.

ZM6 servo riveting system adopts HRC-670 riveting quality monitor for riveting quality control. Communication between the monitor and the servo controller is via a real-time fieldbus. The monitor interfaces to fieldbus types commonly used in the industrial field, such as PROFIBUS, PROFINET, EtherNet/IP, EtherCAT, and the Ethernet port of the monitor enables the transfer of historical data files in a variety of formats. Data backup is also possible.

### ■ Electric Cylinder Parameter

Rated power	KW	5
Electric cylinder stroke	mm	200/300 (Optional)
Nominal Pulling Force	KN	20
Nominal Pressing Force	KN	80
Maximum velocity	mm/s	300
Repeated positioning accuracy	mm	±0.01
Overall weight (including servo motor)	kg	73
Protection class IP54		IP54
Operating temperature		Temperature: -5 ~45°C; Humidity: ≤90%
Operating humidity		≤75%

### ■ Riveting Unit Parameters

Throat depth	mm	200/300/400/450/500/ customized
Operating Opening	mm	130
Maximum pressure	KN	80
Weight	Kg	198/217/238/276/292
User field installation conditions		
Power supply		380V / 480V
Air source	MPa	≥0.6

- (1) Measurement standards assume same temperature working conditions.
- (2) The specific weight of Riveting unit is subject to the final design.
- (3) If the user site installation conditions are special, please contact us.

## Riveting Applications: Lightweight and Compact Design

The ZM6 Servo Riveting system with integrated internal strain gauge force sensor (80 KN ) is particularly suitable for high precision Riveting processes based on force and displacement monitoring. The weight of the whole machine is significantly optimized and requires little installation space. At the same time, excellent weight-center-of-gravity optimized design can be demonstrated when integrating with robot arms.

- ✓ Lightweight and optimized range for robotic applications.
- ✓ Compact design .
- ✓ Servo motors with single cable technology for the easiest possible mounting process.
- ✓ High speeds with ultra-short beats.
- ✓ Active compensation of the riveting process to ensure precise positioning.

### Applications

The ZM6 servo riveting system is suited for modern, fully automated production riveting lines. Due to its lightweight and compact design, the ZM6 has excellent suitability for assembly applications where the robot arm is used. Examples include clinching, punching and pressing.

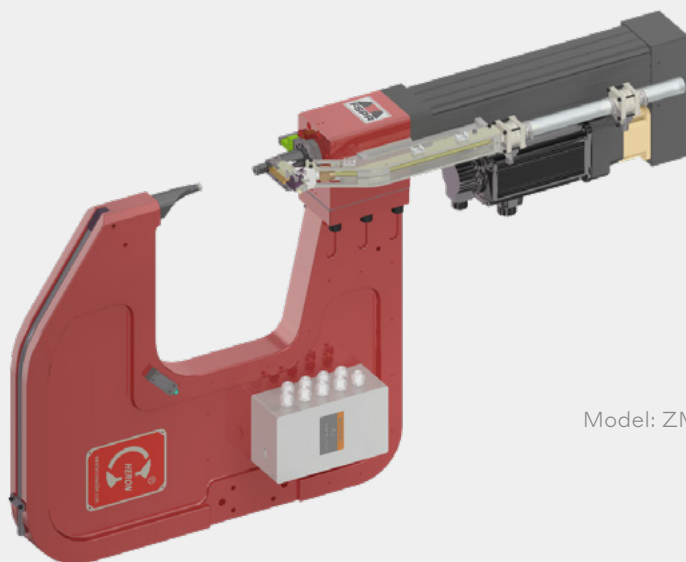

Model: ZM6-080

## Riveting System

Heron's Flush Self-Pierce Riveting (FSPR) Systems range from standard machines to fully automated turn-key operations. We partner with our customers to manage the design, integration and commissioning of assembly systems from concept to production.

In today's market, companies want to improve efficiencies and product quality as well as decrease manufacturing time and labor. Meeting these demands, our customizable multiple-hit automated servo riveting systems make up the majority of riveting equipment sales.

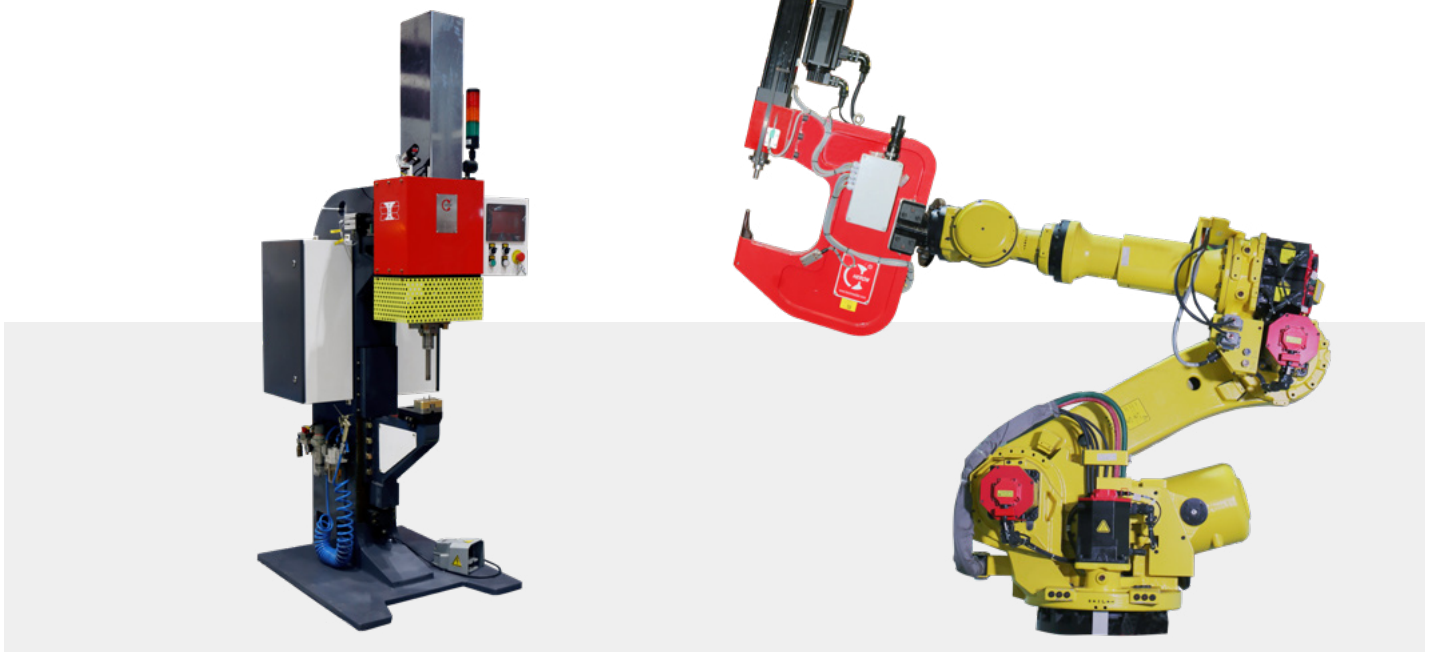

# HT FSPR® System: ZM6 Intelligent Platform

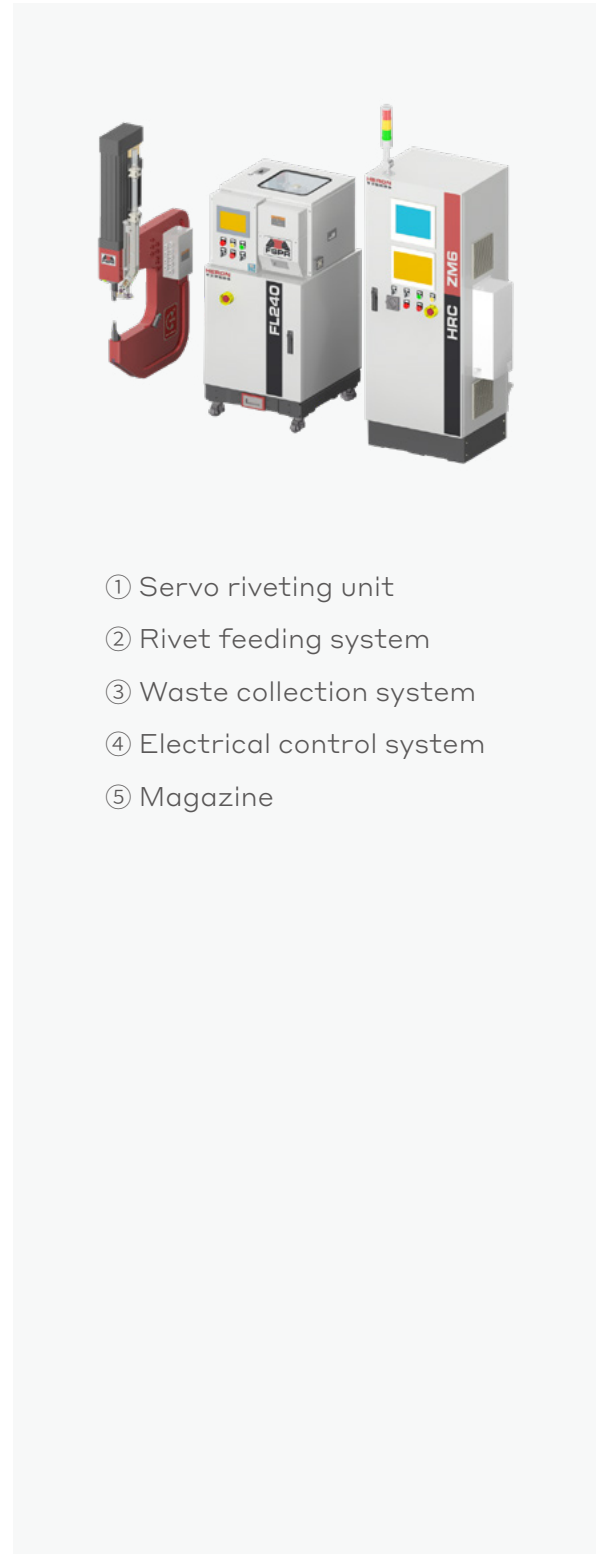
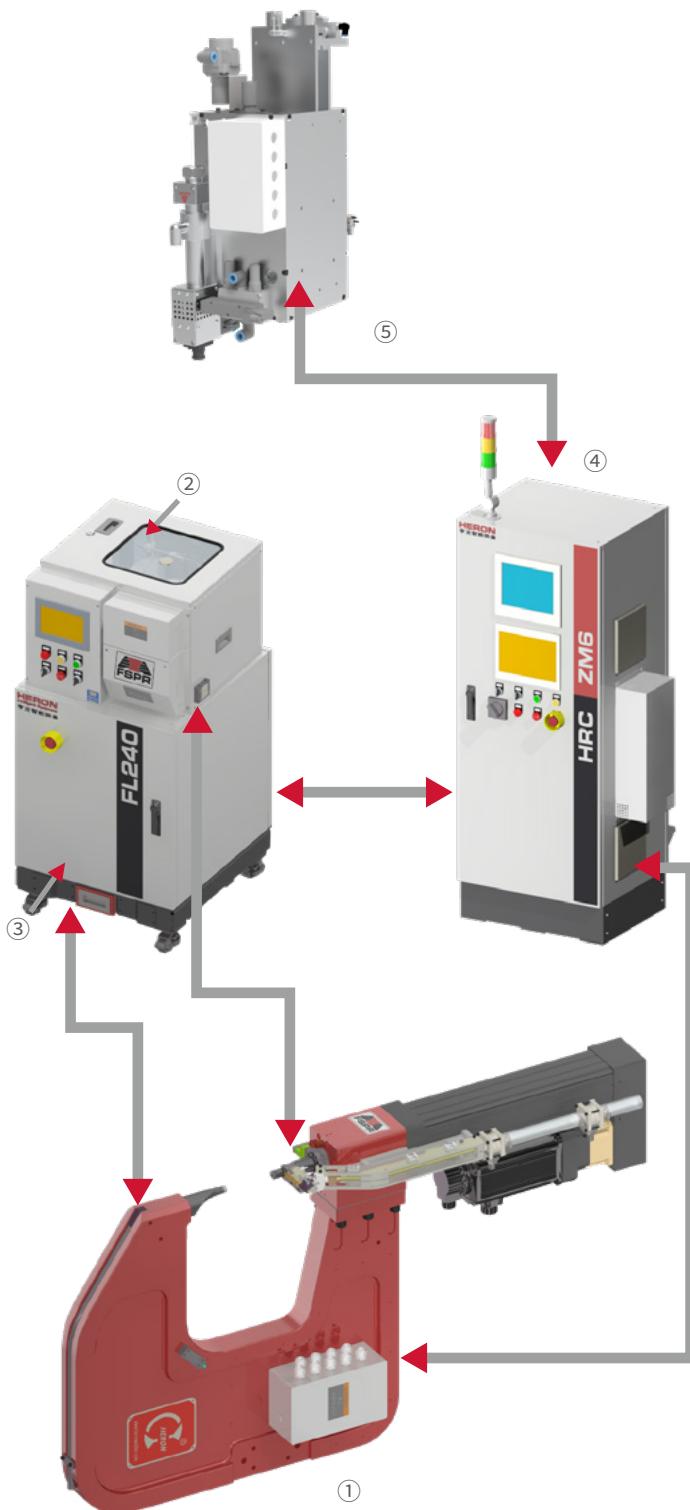

- ① Servo riveting unit
- ② Rivet feeding system
- ③ Waste collection system
- ④ Electrical control system
- ⑤ Magazine

# HT FSPR® System: ZM6 Intelligent Platform

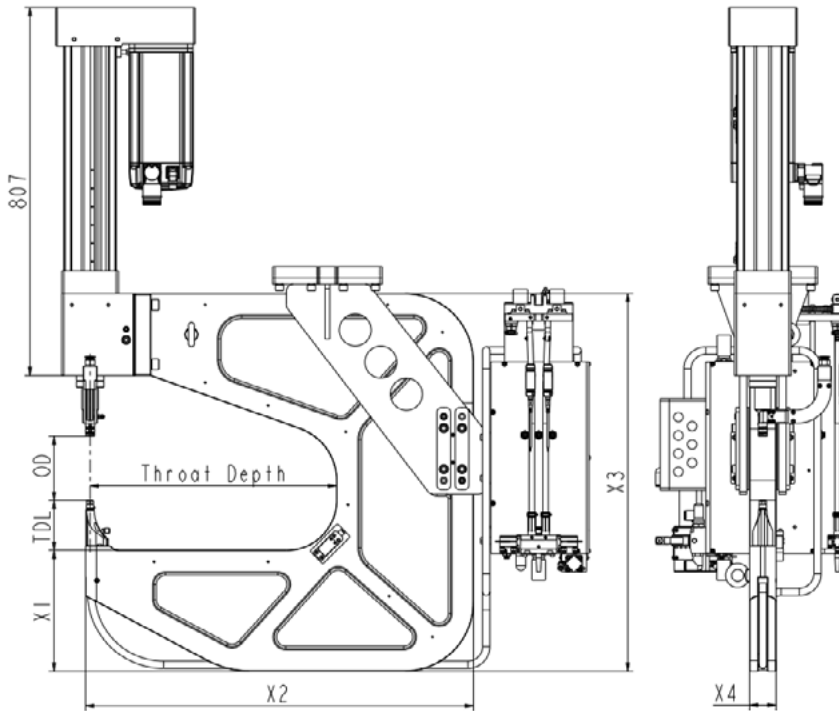

Type	Model No.	Throat Depth (mm)	Weight (kg)	Open Distance (mm)	Total Die Length (mm)	X1 (mm)	X2 (mm)	X3 (mm)	X4 (mm)
C-Frame Options	1	200	198	140	110	200	485	753	50
	2	300	217	140	110	235	585	788	50
	3	400	238	140	110	255	685	808	54
	4	450	276	140	110	260	735	813	56
	5	500	292	140	110	270	810	823	58

1. Basic parameters of standard C-Frame: 200mm Actuator stroke + 150mm open distance.

2. If you need to customize the C-Frame and need more information, please feel free to contact us.

## Rivet Feeder / Waste Collection System

### Rivet Feeder

The system is an automatic vibrating tray type sorting and feeding system. Its function is to vibrate the disordered rivets to be arranged neatly and accurately in accordance with the set direction to the riveting unit, including full material detection, in place detection and no material alarm and other functions.

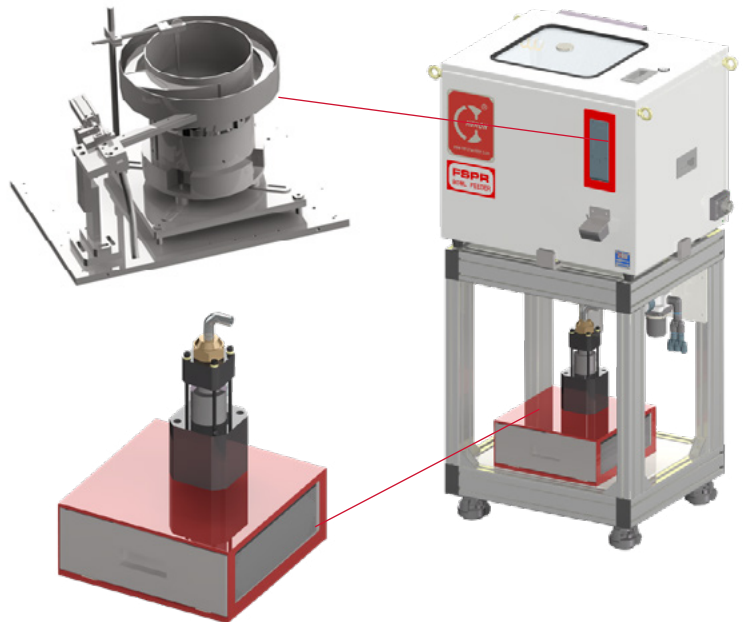

### Waste Collection System

This system is an automated collection system for FSPR punched and cut scrap. It has functions such as counting and alarming.

## Electric Control System

### ZM6-080-XXX-D0 Controller

The control system is used for the overall control of the riveter and the communication with the robot.



# HRC-670 Monitor

HRC-670 monitor can be used for real-time monitoring of riveting, press-fitting, assembly, spring testing and other processes, and form the correlation curve of force, displacement and time to detect and evaluate the production quality or production steps, which can ensure the quality of assembly and achieve defect-free production and assembly parts process. Widely used in the following production tasks:

- FSPR/SPR
- Clinching
- Press fitting
- Spring testing
- Fatigue testing



# FSPR Tooling Selection

## Minimum Space Design Specification

When the size of "E" increases, the size of B should be increased accordingly.

Unless otherwise specified, the values in the table are the minimum values required.

The value of C in the table applies to ordinary mild steel, if riveting low elongation, brittle materials need to appropriately increase the value (\* For example, the die side is about 10% elongation of aluminum, C value is greater than 15mm)

If the size of C increases, the size of D needs to be increased accordingly.

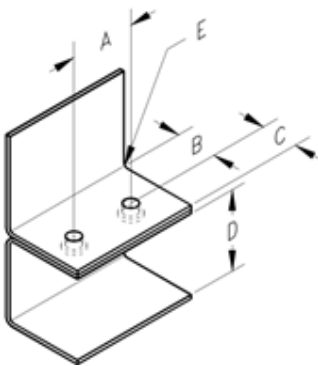
	Tooling		Dim		
	MJ	mm	MSD-1~7	MSD8~11	MSD12~
	A	13	17	20	
	B	7.5	8.8	10.8	
	C	6	8	10	
	D	30	52	65	
	*E	0.8	0.8	0.8	

# Heron: World Class Machines



Add : 63 Xin Yi Road, Guangzhou China, Postal Code : 510990  
TEL : +86 20-87813325 / 87819588 / 87815075



Add : 7750 Zionsville Road, Indianapolis, Indiana USA, Postal Code: 46268  
TEL : +1 317-243-5915

Email: [info@heron-tech.com](mailto:info@heron-tech.com)

24 hours service hotline: **400-088-3325** [www.heron-tech.com](http://www.heron-tech.com)



Youtube



LinkedIn



Wechat

