

**VINYL**  
WINDOWS & PATIO DOORS



**Let life in.**



# SUPERIOR DESIGN AND VERSATILITY MADE EASY

Exceptionally well-built, Durabuilt's vinyl windows are perfect for creating a comfortable and stylish home. Bring home a superior window that fits YOUR style.



## Smooth Sliding

Our Alpha series welcome in the world with a smooth sliding motion and boasts a sturdy, air and watertight design.

## Swing Away

High-performing in every way, our Omega series swing gently open to offer exceptional class, energy savings, and durability.



## TWO EXCITING WINDOWS

# SAME REAL-WORLD BENEFITS

Our Alpha and Omega windows are both built with the same universal monoframe design. This gives you the ability to seamlessly mix and match these high-quality and stylish windows however you want. It also allows for easier selection and consistent installation.



### Common Mullion

Slim profile and more glass

### Sleek Look

Contemporary appearance both outside and inside

### Triple Pane Option

Enhanced energy efficiency and comfort

### Platform Design

- Air and watertight
- Universal Monoframe: 6 1/16" jamb, 1 3/8" exterior nosing — new construction ready
- Also available as continuous Alpha 4 3/8" or Omega 3 1/4" frame for added versatility when adding on interior or exterior trims
- Available in solid White

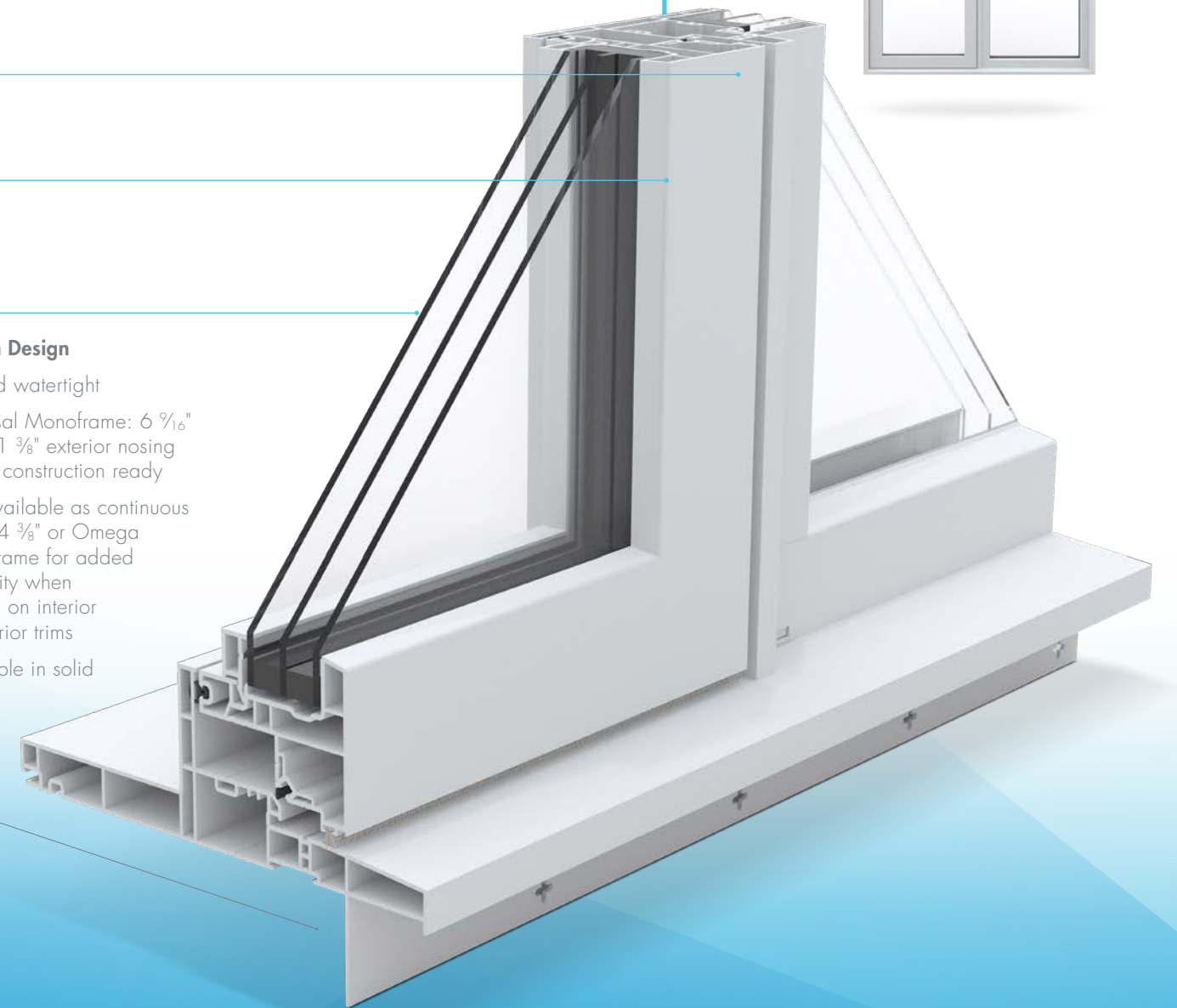
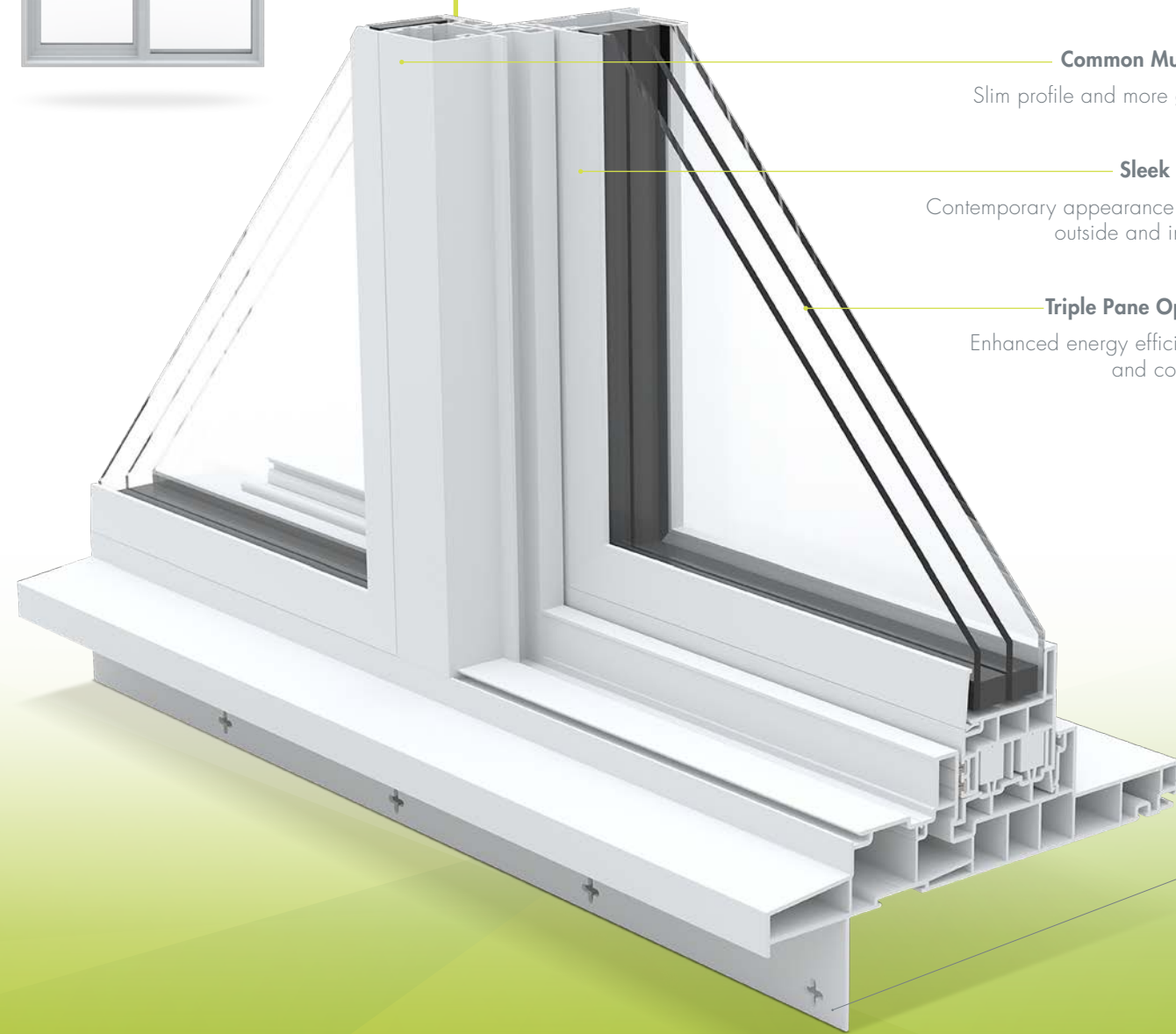



# WINDOWS THAT FIT YOUR VISION



## Let your imagination run wild.

Choose to have your desired venting window stand on its own, or create an exciting combination that meets all of your needs. More natural light? Breathtaking views? With Durabuilt, the combinations are endless.



**Slider**  
Easily glides for direct and efficient ventilation



**Single Hung**  
Slides up and down and stays in desired position



**Direct Set**  
Opens up living space and maximizes natural light



**Sliding Patio Door 2.0**  
Large sliding panel for maximum ventilation and view



**Casement**  
Gently swings open to let fresh air in



**Awning**  
Swings from the bottom out for indirect, subtle ventilation



**Hopper 2.0**  
Opens inward. Used primarily in basements that need to meet egress requirements



**Direct Set**  
Expands natural light and overall view (complementary, non-venting)



**Fixed**  
Achieve a large glass area within a frame when matching sightlines to a casement or awning



**Picture**  
Maximize natural light with a low-profile frame. Available in rectangular, geometric and curved shapes



**Casement/Direct Set**  
Continuous frame combination can be rearranged as you'd like



**Casement/Picture**  
For maximum light and view, and a contemporary look, when mulled to a casement

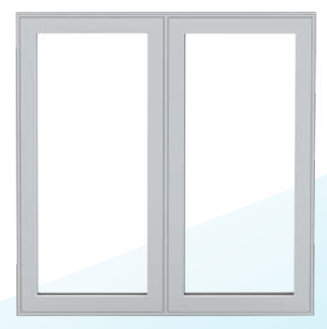

**Casement/Fixed**  
Looking to achieve equal glass sightline? Use a Fixed window in a continuous frame or a mulled window



# ALPHA 2.0 SLIDING PATIO DOOR

The Alpha 2.0 Sliding Patio Door is the robust and versatile solution you need, even in harsh climates.

### Designed With Purpose

Re-engineered and redesigned, the Alpha 2.0 Sliding Patio Door is the new and improved version of the hugely popular Alpha Sliding Patio Door you already know and trust.

### Your Feedback Made it Better

Customers asked for smoother operation and better long-term performance. Our team took that feedback into research and added many key features for Version 2.0



### A Modern Alternative to Traditional Blinds

Enjoy all of the convenience, safety, and ease of cordless blinds without any of the hassle. Our innovative approach places traditional blinds inside the insulated glass for a worry-free, modern experience.

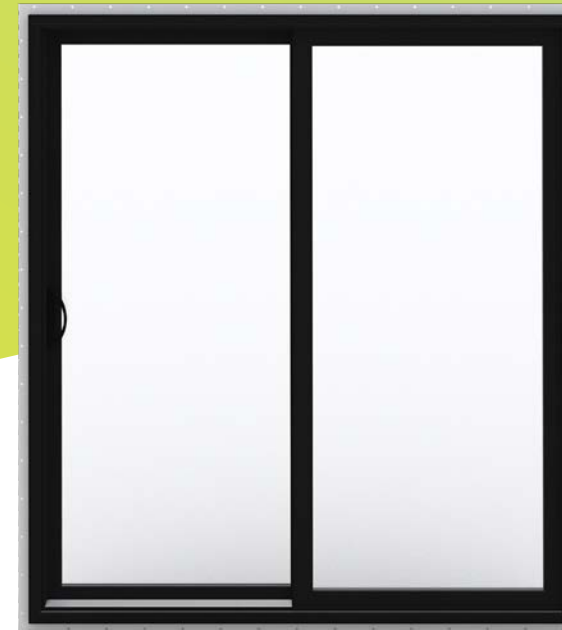

## PERSONALIZED STYLE, STANDARDIZED DURABILITY

Alpha 2.0 Sliding Patio Door features premium Continental® laminate with patented cool colors PLUS technology. Our laminate reflects solar radiation to keep surfaces cooler and reduce heat absorption, even in darker finishes.

The added white reflective backing reduces heat stress in the laminate, minimizing warping and fading for stronger long-term durability and a consistent finish.



### CONTI® COOL COLORS PLUS

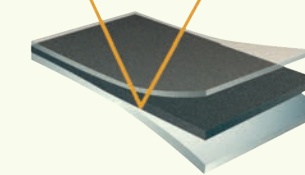

Durable acrylic layer, 100% UV block  
Infrared heat reflective pigmented color  
White base for extra heat reflectivity



9700



9900



9100D

### Patio Door Handles



White



Faux ORB\*



Black



Satin Nickel\*

\*Only available with 9900

### Exterior Laminate Finishes



Jet Black



Sable



Brushed Silver



Iron Ore



Commercial Brown



PVC White (Default)

### Interior Laminate Finishes



Jet Black



Iron Ore



PVC White (Default)

Stylish and well-designed handles are available in various finishes, with optional keyed lock.



Scan the QR code to discover the Alpha 2.0 Sliding Patio Door



## KEY STRENGTHS WE'VE RETAINED

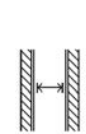

**Vinyl framing:**  
Excellent thermal performance, resistance to warping and minimal maintenance.



**Smooth gliding motion:**  
Easy operation for simple, everyday use.



**Dual- & triple-pane glazing:**  
Reliable energy efficiency, noise reduction and thermal comfort.



**Compatible with Omega and Delta products:**  
Exterior trims available to mix and match for a coordinated, consistent look.



**Integrated blinds:**  
Privacy and convenience.



**Contemporary style and customizable finishes:**  
More design freedom to complement interior and exterior styles.



**Energy efficiency:**  
Stable indoor temperatures with less demand on HVAC.



**Multi-point locking:**  
Trusted protection from forced entry and a tight weather seal.

## MEASUREMENTS & CONFIGURATIONS

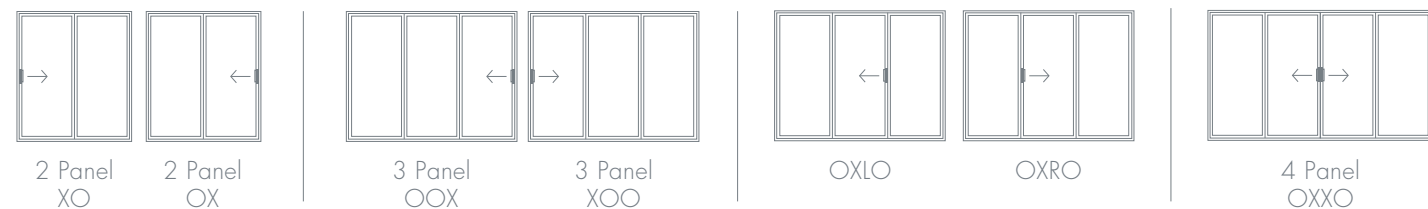

PRODUCT TYPE	MAX WIDTH	MAX HEIGHT
2 Panel Patio Door	8'	8'
3 Panel Patio Door	9'	8'
4 Panel Patio Door	12'	8'
Transom	9'	3'

## GREAT NEW FEATURES

### Easier To Operate

Engineered to reduce strain and extend hardware life.



**Up to 50% less force to open:** Improved track design and wheels for effortless glide, reduced wear on seals, and longer lifetime.



**Strong acetal wheels with quad-roller upgrade option:** Smooth, quiet glide and better support for heavier panels.

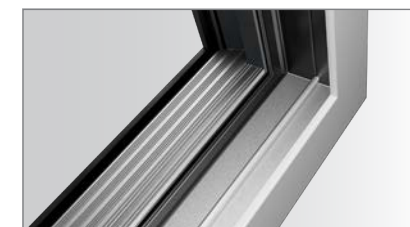

**Thinner threshold with steel reinforcement:** Easier entry and exit with strong support for larger, heavier doors.

### Commercial-Grade Performance

Built to exceed residential standards.

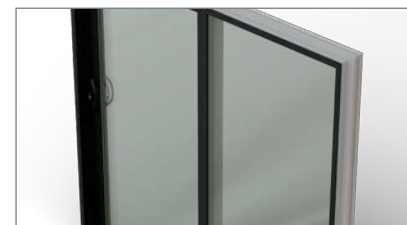

**3x stronger than a standard door:** Rated up to PG60 and designed to withstand winds up to 247 km/h, similar to a Category 4 hurricane.



**Commercial grade water protection:** Tested up to 440 Pa, 2x the industry standard, ensuring reliability in 88 km/h wind-driven rain.

### Premium Design Capabilities

Built for smoother operation and long-term durability.



**German-engineered Roto handles:** Durable hardware with a sleek, modern look and easy operation.



**Modern flat-edge styling, with no crevices:** Contemporary appearance that's easy to clean and maintain.

# COLOUR AND FASHION

Transform your Alpha and Omega windows with our contemporary colour palette. Our robust laminate finish is easy to maintain and will hold its colour beautifully for years.

Let your imagination run wild



## Exterior Laminate Finishes

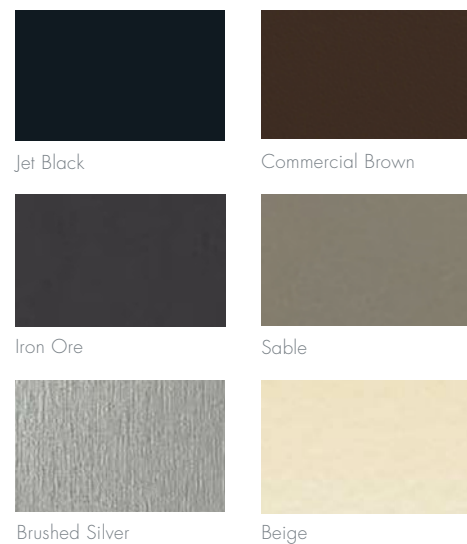

## Unique to Omega

High-performing and unquestionably classy, our Omega windows offer you exciting, exclusive features.

### Interior Laminate Finishes

Two interior finish options that support today's contemporary design trends. You can also introduce a rich woodgrain and stain or paint as you'd like.



### Stylish Smooth Operator

Our top-quality Roto® hardware features a low-profile, tuck away handle and cover, available in White and Beige to match your windows, or in other stylish fashion finishes. Low profile, locking and operating hardware offers ease of use and secure functionality.

### Aluminum Clad

Durable aluminum exterior with clean, crisp lines. Offered in Black, Commercial Brown, Iron Ore and Sable painted finishes.

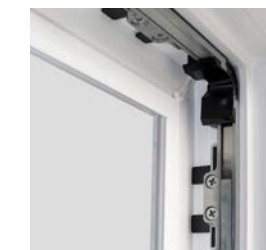

### Tight Sealing Solution

Roto® Corner Drive is an extension to our standard multi-point locking hardware. It's ideally used on taller casement windows to ensure a tight seal.

### Available Fashion Finishes



### 2" Aluminum Reno Brickmould

Replicates a traditional appearance and makes replacement installation simple.



# ACCESSORIES AND OPTIONS

Customize to fit your desired design and any/all construction specs.

## Exterior Trims

New construction choices



**1 1/4" J-trim Brickmould**  
Allows siding to neatly tuck away

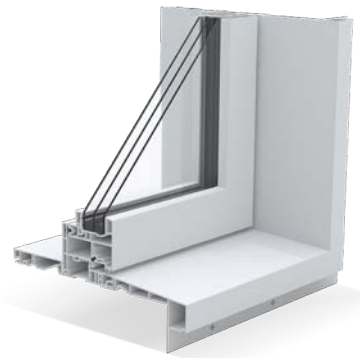

**3 1/4" Exterior Extender**  
Moves the window further into the wall, making it ideal for ICF or other wide-wall assemblies



**Exterior Panning**  
Extends the frame allowing you to install exterior insulation up to the window frame

## Exterior Trims

Renovation solutions



**2" Brickmould w/ Sloped Sill**  
Offers the look and function of a typical wood window. Removable finish strip simplifies installation. Also available in 2" on all four sides



**1 1/2" Brickmould w/ Sloped Sill**  
Offers a slimmer profile. Available in 1 1/2" on all four sides



**Rebate Flange**  
Handy solution that can be used at the window sill only, or on all four sides to cover existing material

## Interior Trims

Fit & Finish



**Jamb Extension**  
Your choice of vinyl, stain grade, or paint grade wood. Available in standard and custom jamb widths up to 12"



**U-Channel Return**  
Easily accepts your choice of 1/2", 5/8" or 3/4" material so you can finish as you'd like

Lifetime Warranty Guaranteed.

## Unique to Alpha 2" Brickmould Monoframe



Designed with an integral 2" brickmould, making it airtight, watertight, and a snap to install. Perfect for replacing old aluminum or plastic siding windows



# LITE IT UP

## Details

### Divided Lites — GBG & SDL

Create unique architecture and infuse personality into your home with the look of divided lites. Options include placing a grille between the glass panes (GBG) or adhering simulated divided lites (SDL) to the interior and exterior of glass. Either way, the end result is nothing short of stunning.



### Simulated Divided Lites

Available widths include 1", 1½", and 2 ⅜" width

Exterior and interior finish will match your window finish choice



### Grilles Between Glass

Available widths include ⅝", ⅜", and 1"

### Colours



White



Beige



Black



Pewter



Commercial Brown

Commercial Brown and Black are available in a split finish white interior in ⅝" and 1" widths

# INSULATED GLASS

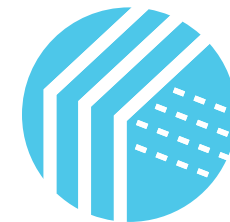

Triple pane

## Glass and Window Performance

What would a Durabuilt window be without its real performance glass? Whether you choose triple pane, dual pane, or low-e solutions like Sun Gain ER or Solar Block U with argon gas, you'll receive superior performance and comfort requirements with the additional benefit of energy savings. Even better, for enhanced thermal efficiencies and reduced condensation, Durabuilt windows feature warm-edge premium spacer bars.

All of our Alpha and Omega windows are tested to NAFS/CSA and Energy Rating standards. Bottom line, our windows meet and exceed today's energy and structural requirements.



Low E



## Clean Less, Live More with EasyClean+

Durabuilt's already high-quality, prairie-tested windows have even better clarity and longevity thanks to EasyClean+ Glass Technology.

Glass may appear smooth, but it's made up of microscopic peaks and valleys where contaminants can get lodged and stuck, compromising the clarity of your windows. EasyClean+ fills in these peaks and valleys and creates a smooth, seamless surface that protects against moisture, dust, scum, and debris, as well as hazing, yellowing, and general aging.

As a result, enjoy crystal-clear high-performing windows for the entirety of their lifetime, guaranteed!



Cut your cleaning time by up to 90%



All you need is water, no more harsh cleaners



Repels moisture and all other contaminants



100% optically-clear windows



Won't yellow, haze, fade, or corrode



Scratch resistant

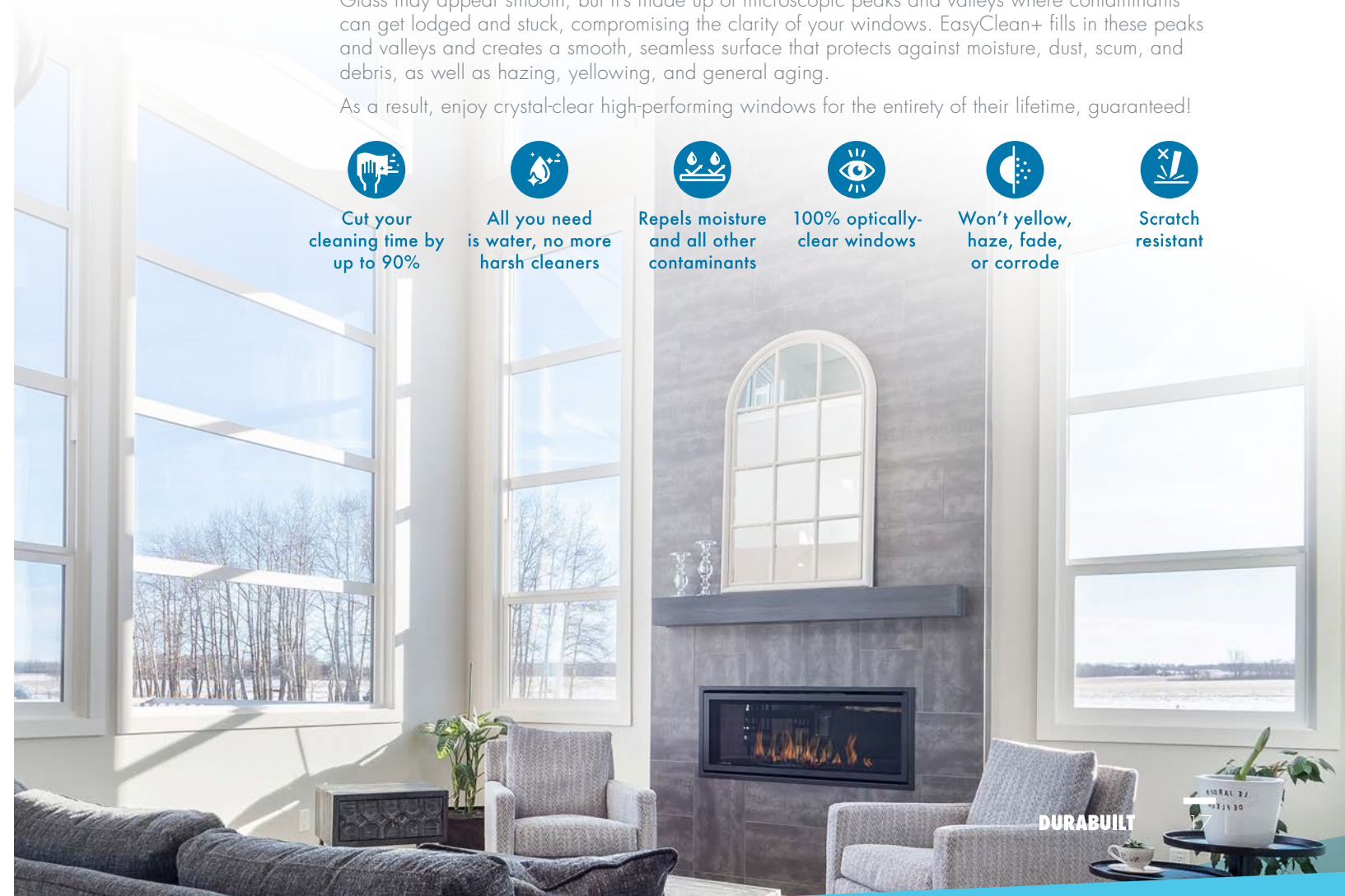

DURABUILT



## We Have You Covered

The entire Durabuilt team is committed to YOU. Why? Because we know that a home is more than a handful of walls and some shingles. It's where memories are made, families grow, and worlds are shaped.

# Let's get started.

