

# USITT.

GRAPHIC 

**recommended**

 PRACTICE

# 1.0 BACKGROUND

This latest version of USITT Graphic Recommended Practice (USITT—GRP) is intended for use on all productions and projects involving live entertainment. The original 1982 and 1992 revised versions, identified as the USITT Scenic Design and Technical Production Graphic Standards, were developed for hand drafters, since CAD was still in its infancy at that time. This document melds those documents with today’s dominant CAD uses to create an “in-progress” Graphic Recommended Practice.

This edition, reidentified as a Recommended Practice, leaves it to the user to decide which practices and specifications to incorporate in their own work. However, good graphic communication remains the same whether done by pencil or computer so in that regard little has changed. Drafting techniques specific to CAD or hand drafting are clearly labeled as one or the other, if the distinction is of any importance.

This document is intended to guide drafting work both within a specific organization and within the entertainment field nationally. Following these techniques will produce information in a clean, efficient, and consistent manner that can be shared with colleagues and partners and serve to guide the instruction of students and young professionals.

This version was created using both the USITT 1992 Graphic Standard and the United States National CAD Standard (USNCS\_Version4) as its baseline. Expectantly, it will be updated as subsequent USNCS releases are published. This and future versions are meant to be platform-neutral, i.e., applicable to both existing and future drafting software applications.

## 1.1 INTENT

- 1.1.1 This document aims to classify design and construction data consistently, to streamline and simplify the exchange of data within design and construction departments, and to demonstrate the appropriate presentation of two-dimensional graphic practices (no 3D-specific practice is addressed at this time). Drafters using this guide should note that any drawing information supplied must be clear, specific, consistent, accurate, comprehensive, and tailored to the needs of the end user, be they drafter or reader.
- 1.1.2 The purpose of the USITT—GRP is to enable efficient transfer of information during both the design and construction phases of a project among the critical parties, including: producer, director, designer, technical director, consultants, department heads, and vendors.
- 1.1.3 Postproduction use of USITT—GRP is intended to facilitate any utilization of archival design and construction documents.

## 1.2 SCOPE

- 1.2.1 USITT—GRP assists in classifying and organizing electronic data within CAD data files, addressing issues such as layer names, line weights, dimensions and notation, symbols, and the graphic organization of design and construction drawing sheets.
- 1.2.2 Implementation of USITT—GRP is intended to facilitate the exchange of data between current and future CAD software and to ensure the future utility of existing CAD data files.

## 1.3 IMPLEMENTATION

1.3.1 Implementation of USITT—GRP, in whole or in part, is voluntary. Each organization should establish its own degree of conformance, noting that agreements between producer and design professional, or between design professional and consultant/contractor, should require a specified level of conformance.

# 2.0 LINES

The clear use of different line forms, thicknesses, and colors helps convey specific meaning. Standardization of line forms and weights is important to establish a logical hierarchy within the drawing, leading the reader instinctively to the most essential information.

## 2.1 LINSTYLES

2.1.1 Each line is made of two variable elements: thickness and type

- **Thickness** (frequently identified as “weight,” i.e., “lineweight”)

*Recommended thicknesses: Thin (.015mm); Medium (0.30mm); Thick (0.60mm) + Extra-Thick (0.70mm)*

*If modifying the above, note that lineweight thicknesses typically use a 4:2:1 ratio to facilitate distinction.*

- **Type** (continuous, short dash, long dash, combination long and short dash, etc.)

Together, these two elements form a “linestyle.” These line types, their approximate proportions, and their associated widths and purposes are to be used wherever possible. Avoid creating and using personal linestyles; if a new symbol is employed, provide clear notation (usually in a legend) to define the additional linestyle’s meaning.

### 2.1.2 LINEWEIGHTS

2.1.2.1 <b>THIN</b>	0.15 mm	0.006 in	sightlines, hatch lines, arrows, dimension and extension lines
<b>MEDIUM</b>	0.30 mm	0.012 in	object lines, notes & dimensions
<b>THICK</b>	0.60 mm	0.020 in	cutting plane lines, title block/strip
<b>EXTRA-THICK</b>	0.70 mm	0.027 in	border









**2.1.2.2 Lineweights (Pencil)** *(This recommendation is a modified ANSI standard)*

Pencil line weights can be varied by pressure and sharpness of lead. Mechanical pencils (left column); Graphite lead holders (right column) use 2mm leads of varying hardness.

	Mechanical pencils	Graphite lead holders
<b>THIN</b>	0.30 mm	2H, 4H
<b>MEDIUM</b>	0.50 mm	HB, B
<b>THICK</b>	0.70 mm	HB, B
<b>EXTRA-THICK</b>	0.90 mm	2B, 3B, 4B

**2.1.3 LINETYPES (Symbol & Thickness)**

**2.1.2.2 Continuous lines**

Object Line (default)	Medium (0.30 mm)	
Set Line	Thin (0.15 mm)	
Leader line	Thin (0.15 mm)	
Section/Hatch line	Thin (0.15 mm)	
Sightline	Thin (0.15 mm)	
Title Block/Strip	Thick (0.60 mm)	
Section Outline	Thick (0.60 mm)	
Border	Extra-thick (0.70 mm)	
Architectural Outline	Extra-thick (0.90 mm)	

**2.1.3.2 Dashed lines**

Hidden	Thin	
Ceiling Line	Thin	
Plaster Line	Thin	

**2.1.3.3 Phantom lines**

Default	Thin	
---------	------	--

**2.1.3.4 Centerline lines**

Default	Thin	
---------	------	--

## 2.1.3 INDUSTRY SPECIFIC LINES

### 2.1.3.5 Break lines

Long	Thin	(0.15 mm)
Short	Thin	(0.15 mm)

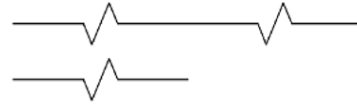

### 2.1.3.6 Section solid

Thick (0.90 mm)



### 2.1.3.7 Cutting plane

Default	Extra-Thick	(0.70 mm)
Alternate	Extra-Thick	(0.90 mm)

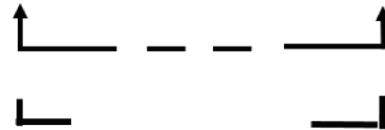

## 3.0 NOTATIONS

Drawings and notation must be complete, accurate, and effectively communicate the project to the drawing user in the simplest, most efficient manner possible. The placement of notes within the drawing block should comply with the drawing block format requirements, see §8.5.

### 3.1 NOTATION FORMAT

Fonts should be upper case, a common font, and proportionate. In most situations use a sans-serif font such as one of the five recommended fonts (see §3.4). Do not use italics, underlining, bold, or other highlighting techniques.

### 3.2 NOTATION VOICE

**3.2.1** CAD systems have made the preparation of notes less burdensome, but also made it easy to create overly lengthy notes, thereby diluting efficient communication. In general, notation should employ leader lines with short notes, reference keynotes, or sheet keynotes. The latter, which replace words with a simple symbol and legend, are recommended over prose. Incorporate suggestions from The Project Resource Manual—CSI Manual of Practice to use “streamlining” (commonly known as “active voice”) and the “imperative mood” as methods to reduce language and clarify specifications.

**3.2.2** Apply the above principles to drawing notes, as illustrated below:

- Avoid “indicative mood”: CONTRACTOR SHALL NOT SCALE DRAWINGS
- Use “streamlined voice”: DO NOT SCALE DRAWINGS

### 3.3 NOTATION EFFICIENCIES

**3.3.1** Match the generic terminology used by manufacturers. The names of materials and products noted on the drawings should be identical to the generic names used to identify these items. Identify objects and materials on the drawings with generic terminology and, if possible, a description adequate to differentiate similar/comparable products.

**3.3.2** Write notes using complete terminology and use only commonly recognized abbreviations, see §3.6.

**3.3.3** References to written specifications and/or other drawings should provide the reader with an exact reference location. In the case of drawing sets, identify the reference by specifying sheet and drawing numbers.

### **3.4 FONTS**

On any drawing or drawing set, choose from only non-serif fonts and use only a single font on any one detail drawing whenever possible. Below are examples of attractive, easy-to-read, and readily available fonts. Differentiate importance or emphasis by adjusting font size, see §3.5.

- CITYBLUEPRINT
- ROMAND
- ARIAL
- CALIBRI
- SANS SERIF

### **3.5 TEXT SIZES (actual size varies by font style and legibility)**

- Notes & Dimensions                      3/32" - 1/8" height (10-13.5 font size)
- Labels    3/16" height (20 font size)
- Titles    1/4" height (26.5 font size)

### **3.6 COMMONLY RECOGNIZED ABBREVIATIONS (sampling only)**

Alternate = ALT	Each = EA	Muslin = MUS
Outside Diameter=OD	Sheet = SHT	Tongue & Groove = T&G
Center Line = CL	Hardware = HDW	Not To Scale = NTS
Plaster Line = PL	Stage Left = SL	Typical = TYP
Diameter = DIA	Inside Diameter = ID	On Center = OC
Plywood = PLY	Stage Right = SR	White Pine = WP
Do Not Cover = DNC	Loose Pin Hinge = LPH	Above Finished Floor = AFF
Reverse & Repeat = R&R	Tight Pin Hinge = TPH	Unless Otherwise Noted = UON

## **4.0 DIMENSIONS**

### **4.1 UNITS OF MEASUREMENT**

- 4.1.1** In the United States, the standard system of measurement for length is the imperial system, i.e., feet and inches. For CAD, set the precision level to 1/16" (or 1/8") unless the project calls for greater precision.
- 4.1.2** The standard system of measurement for angles is the decimal system. Set the precision level to whole numbers, except for instances requiring increased accuracy such as machining, or if shop equipment allows greater accuracy.

## 4.2 UNITS & PLACEMENT

- 4.2.1 Dimensions must be clear, consistent, and easily understood.
- 4.2.2 Orientation of dimensions should follow ANSI recommendations of Unidirectional or Aligned Systems, using only one method throughout a drawing or set of drawings.
- 4.2.3 Imperial dimensions that are less than 1'-0" are given in inches without a foot notation, such as: 6", 9-½", etc. Dimensions greater than 1'-0" appear as a whole number with a single apostrophe followed by a dash, then inches followed by a double apostrophe, e.g., 1'-3", 7'-½", 18'-5¼", etc.
- 4.2.4 Metric dimensions less than one meter are given with a zero, decimal point, and a portion of a meter in numerals, e.g., 0.18cm, 0.52m. Dimensions greater than one meter are given as a whole number, decimal point, and portion of meter, e.g., 1.5cm, and 2.35m.
- 4.2.5 Position dimensions 1/16" above the dimension line or centered within a broken dimension line, allowing a 3/32" gap of white space on each side.

## 4.3 EXTENSION & DIMENSION LINES

- 4.3.1 Extension lines allow 1/16" gap of white space between the object and the tail of the extension line.
- 4.3.2 Dimension lines run between extension lines and should allow for a ½" gap between object and dimension line and for a ¼" to ⅜" space between dimension line, determined by the choice of dimension position.
- 4.3.3 Dimension lines should be punctuated at the ends with an appropriate arrowhead or thick lineweight 45° slashes (Architectural tick). Arrowheads should be about ⅛"-3/16" in length.
- 4.3.4 Dimensions should be the same height as notation, typically ⅛". To avoid squeezing dimensions into spaces that are too small to accommodate fractions, use a leader line with an arrow at the end to indicate an edge or direction.
- 4.3.5 Use a leader line with dot on the end to identify a surface.
- 4.3.6 Any leader line should meet the note at the middle of the note's first or last word with a 1/16" gap between line and notation.

## 4.4 CIRCLES & ARCS

- 4.4.1 A circle is dimensioned by its diameter: an arc by its radius.
- 4.4.2 Diameter dimensions should be preceded or followed by "DIA" or "Ø".
- 4.4.3 Radius dimensions should be preceded or followed by an "R" and be at the end of a leader line with one arrowhead touching the arc.

## 4.4 CIRCLES & ARCS

4.4.4 Angle size should be preceded or followed by a “<”.

4.4.5 All circles, arcs, and holes should be accompanied by a center mark that includes quadrant intersections, see §4.5.4.

## 4.4 COMMON DIMENSION SYMBOL SHORTHAND

4.5.1 Diameter =  $\varnothing$

4.5.2 Radius =  $R$

4.5.3 Angle = 

4.5.4 Circle = 

## 5.0 DRAWING SHEETSIZES

5.1	Paper System	Designation	inches	mm
	<b>ANSI</b>	A	8.5 x 11	216 x 279
		B	11 x 17	279 x 432
		C	17 x 22	432 x 559
		D	22 x 34	559 x 864
		E	34 x 44	864 x 1118
	<b>Architectural</b>	A	9 x 12	229 x 305
		B	12 x 18	305 x 457
		C	18 x 24	457 x 610
		D	24 x 36	610 x 914
		E	36 x 48	914 x 1219
		E1	30 x 42	762 x 1067

## 6.0 SCALE

All CAD drafting (Model Space) is drawn full size (1:1 scale). Printed drawings (Paper Space) are sized to fit on paper sheets, scaled to the purpose (see §6.1) and degree of accuracy required.

6.1 Drawing scales shown below are in imperial units and appropriate to the type of project, allowing for adequate detail and clarity. Examples of typical scales are:

$\frac{1}{4}$ " = 1'-0" Ground Plans and Sections

$\frac{1}{2}$ " = 1'-0" Ground Plans, Sections, Elevations, and Construction (Shop) Drafting

1" = 1'-0" Small object Elevations and Construction (Shop) Drafting, and Details

3" = 1'-0" Very-Small Object Drawings and Details

1" = 1" (1:1) FULL SIZE: for maximum precision

# 7.0 LAYERS / CLASSES

## 7.1 DEFINED LAYER NAME DATA FIELDS

An identification field is used to group all layers from a single department (discipline) together within an organizational data string, e.g., S - EL - DIMS.

- 7.1.1 Discipline Designator (mandatory)
  - the category of subject matter contained on the specified layer — a single-character field
- 7.1.2 Drawing View Layer Name (mandatory)
  - specialized code for layers that are organized primarily by drawing type
- 7.1.3 One or two Minor Groups (optional)
  - What the layer consists of: e.g., walls, platforming, handrail, etc.
  - Drawing included in the layer
- 7.1.4 Each data field could be separated from adjacent fields by a dash (“-”) for clarity. For example, the designation below reads as:
  - S - E L - D I M S = Scenery - Elevation - Dimensions
  - SELWALLS = Scenery Elevations Wall
  - CP1 = Construction Drawings Platforming #01

## 7.1 DEFINED LAYER NAME DATA FIELDS

Discipline Designators		Minor Groups	
A	Architectural Structure	DIMS	Dimensions
U	Audio	LABL	Labels
L	Lighting & Electrics	LEGN	Legends/Symbol Keys
J	Projections	NOTE	Notes
P	Props	REVC	Revision Clouds
S	Scenery	REVS	Revisions
E	Special Effects	SYMB	Reference Symbols
C	Construction Drawings	TABL	Data Tables
		TEXT	Text
		TITL	Drawing & Detail Titles
Dwg. View	Layer Name	TTLB	Border & Title Block
	EL Elevations	DDNN	Discipline Dwg # - 2 digits
	DT Details		
	GP Ground plan		
	SC Section		
	RI Riser Drawing		
	RG Rigging		

### 7.3 LAYER COLORS (CAD)

Individual layers should be assigned different colors for ready recognition on the monitor screen. Within organizations, layer color selection is frequently dictated by the company's implemented plot style.

7.3.1 Layer colors are difficult to mandate due to factors such as organizational preferences, layer systems, and the issue of color-blindness.

7.3.2 Below are several suggestions that enjoy wide consensus:

Color	Layer	Use
White/Black	Default	Blocks, etc.
White/Black	LN	Object Drawing Lines
Red	DIM	Dimensions
Red/Magenta	TXT	Text, Notation
Green	DAT	Reference & Center Lines

## 8.0 DRAFTING SHEET CONTENTS & ORGANIZATION

### 8.1 BORDER

A drawing border is strongly recommended to ensure that the complete drawing is included on the print media. The border should be kept simple and clear, the recommended choice being a continuous extra-thick line. While sheet/border size recommendations are presented below, the border placement should be based on the printer/plotter's printable area (CAD).

8.1.1 A 1/2" border should be maintained from the sheet's edge, except the left border which should be inset 1-1/4" to accommodate the full file name (folder file string) outside of the left border edge (See §8.4-(CAD only)).

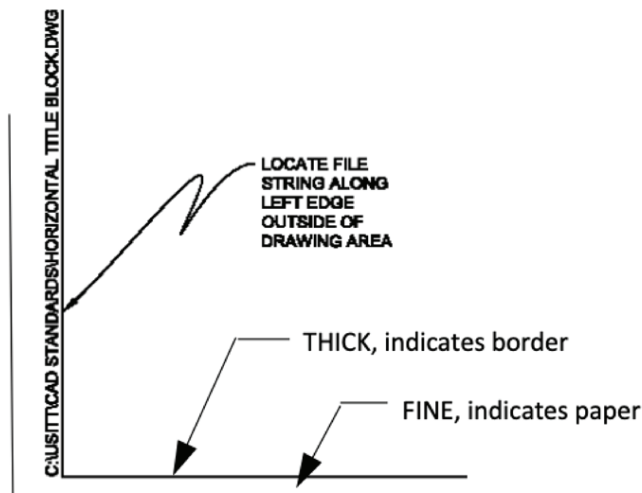

**FIG. 8.1** If drawings are to be bound, the left margin should be 1-1/2" to accommodate binding.

## 8.2 TITLE BLOCK/STRIP & CONTENT

Normally, the Title Block/Strip is anchored to the drawing sheet's bottom right corner and read from either the bottom or right-side edges. The position of the title block should be changed only in exceptional circumstances, e.g., the drawings are to be stored on a hanging rack. The drawing's title and number should remain clearly visible when the drawing is folded. If the left-hand edge of the title block/strip meets the top border line, the area between left and right lines provides space for other information including notes, revisions, etc. Line and text widths and layout within the title block should be chosen for greatest clarity.

**FIG. 8.2.2** Vertical Title Strip Format

Drawings Block and Strips should have the following information:

- Producing Organization Name (and contact information as space allows)
- Show Title
- Plate Title
- Director Name
- Scenic Designer Name
- Technical Director Name
- Drafter Name
- Checker/Approval Name (if not needed, list as N/A)
- Plate Number
- Drawing Date
- Scale
- Filename or Full File String (If not placed along left border edge outside of border) (CAD only)

COMPANY LOGO

COMPANY NAME  
987 ADDRESS ST  
CITY NAME, ST 98109

TEL: (###) ###-####  
FAX: (###) ###-####  
EMAIL@THEATER.ORG

VENUE NAME

SHOW NAME

REVISIONS:	NO.	DATE	DESCRIPTION	PLATE
#	MM/DD/YY	DESCRIPTION OF THE REVISION GOES HERE.		#

DIRECTOR NAME  
SET DESIGNER NAME  
TD NAME  
DRAFTER NAME  
MM/DD/YYYY  
AS NOTED ARCH D  
SHEET TITLE  
##  
OF ##

**FIG. 8.2.1** Horizontal Title Strip Format binding.

COMPANY LOGO

COMPANY NAME  
987 ADDRESS ST  
CITY NAME, ST 98109

TEL: (###) ###-####  
FAX: (###) ###-####  
EMAIL@THEATER.ORG

REVISIONS:  
DATE DESCRIPTION

SHOW NAME

PLATE NAME: PLATE TITLE PLATE #

TECHNICAL DIRECTOR: TD NAME DATE: MM/DD/YYYY

DRAWN BY: DRAFTER NAME SCALE: 1/4"=1'-0"

**FIG. 8.2.3** Corner Title Block Format

NAME OF ORGANIZATION	
SHOW TITLE	
SCENIC UNIT & PLATE TITLE	PL #:
DIRECTOR:	OF
DESIGNER:	
TECH DIRECTOR:	
DRAFTER:	
APPROVED:	SCALE: $\frac{1}{2}''=1'-0''$ DATE: 8/24/09
FILE NAME:	

### 8.3 REVISION TRACKING LEGEND

Locate the revision legend near the title block, (Fig. 8.3), or within the title strip itself when using one of these formats (see Figs. 8.2.1 or 8.2.2).

8.3.1 When using a title block versus strip, list the revision information in reverse order, i.e., most recent changes placed at top of list). To accommodate expected revisions, leave sufficient space, e.g., 1-½” – 2”, above the title block.

8.3.2 Revision legend should include Revision #, Date, Drawing # and sheet #, plus brief description.

**FIG. 8.3** Revision Legend Typical Location on Drawing Sheet

Revisions :		
Date :	Description :	
<b>Company</b>		Production Office Any Street TOWN, A1 2BC Tel: 0123 45678 Fax: 0123 45679 po@company.org
Theatre Royal		
The Greatest Show on Earth		
GroundPlan Act 2, Sc.3		
Scale :	Date :	Drawn By :

### 8.4 ELECTRONIC FILE STRING RECORD KEEPING

To keep a complete file management system, the entire string should be located somewhere on the drawing. The location shown in Fig. 8.1 is non-invasive and easy to locate on each drawing, provided standard sheet practice is observed.

### 8.5 NOTES

- General notes should be placed above or to the left of the title block/strip.
- Local notes are attached to the reference features with leader lines and arrows. Use local notes whenever possible.



**FIG. 8.7.2** Element drafting with detail views

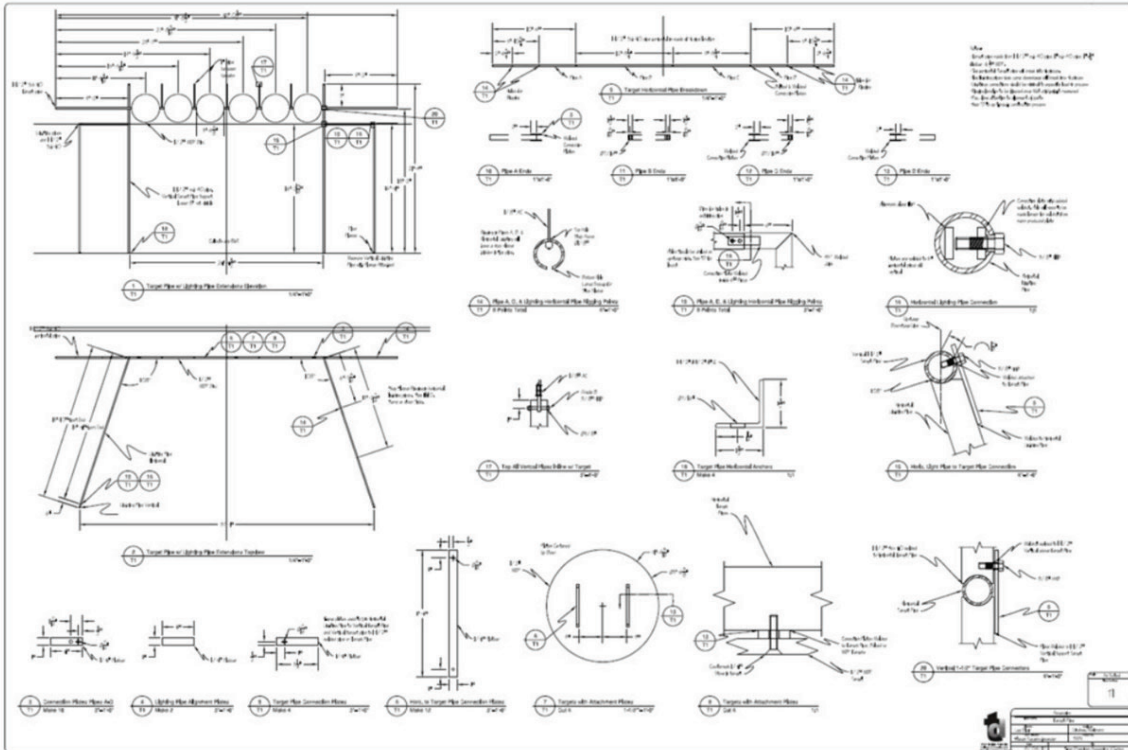

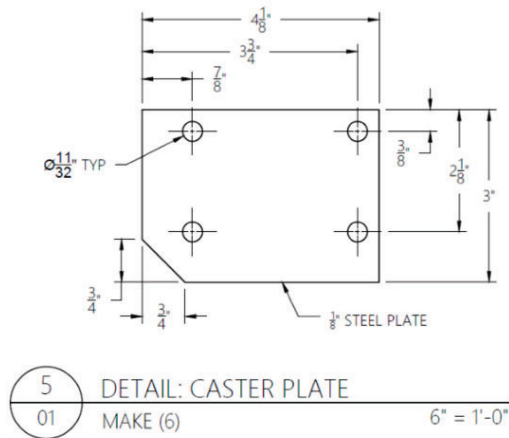
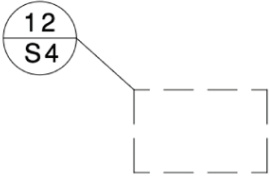
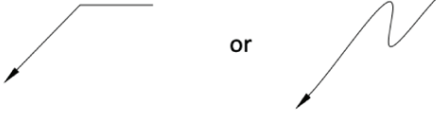
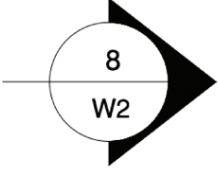
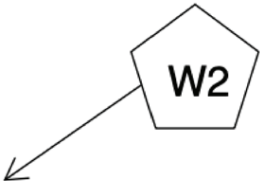

**FIG. 8.7.3** Detail drawing Format







## 9.0 SYMBOLS / BLOCKS / RESOURCES

The use of blocks is encouraged, to promote consistency, and reduce any repetitive drafting needed for inclusion, correction, or alteration. Create blocks on the default layer in full size (scale 1:1) using the default linetype and color. Any block with a potential use beyond the current project should be added to the drafter’s personal symbol/resource library as a stand-alone file. Below are samples of common USITT scenery graphic symbols. USITT also has recommended practice symbols for Lighting and Audio purposes that are offered as stand-alone documents; available from the national office or on the USITT website: [www.usitt.org](http://www.usitt.org)

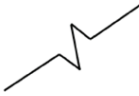
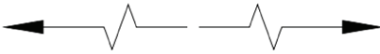

## 9.1 STANDARDIZED BLOCKS/SYMBOLS

Symbol Name	Symbol	Notes
Detail Reference w/ Outline Box		Top portion of circle for drawing #, bottom portion for Plate #. Hidden line box outlines detailed section.
Leader Line		Callouts
Section Reference		Top portion of circle for drawing #, bottom portion for Plate #. These indicate where to find section. Arrow direction indicates view direction
Scenic Unit Reference Icon		Place Letter of Unit in Pentagon
Drawing Label		Top portion of circle for drawing #, bottom portion for Plate #
Revision Cloud		Line weight is consistent with dimensioning

## 9.1 STANDARDIZED BLOCKS/SYMBOLS

Symbol Name	Symbol	Notes
Set Line		Text Height is 1/4" and on top of line
Center Line		Text Height is 1/4" and on top of line
Plaster Line		Text Height is 1/4" and on top of line
Break Line		Place to show an object continues
Break Line Dimensions		Replace existing dimension lines to show a break in dimensioning
Break Cylindrical		

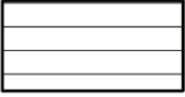
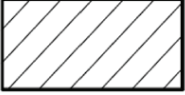
## 9.2 HATCHES

Use	Example	Hatch	Scale
Plywood		LINE	1
Wood		ANSI31	1
Steel		STEEL	1
Composite		AR-SAND	.125

### 9.3 SOFT GOODS / DRAPES & DROPS

- 9.3.1 Drapes or drops that are flat hung and touch the stage deck are depicted by a solid thick line and terminated with a perpendicular thin line at each end. Using CAD, draw the thickness true size.
- 9.3.2 Drapery that is flat hung and flown overhead is depicted by a thin uniformly long dashed line.
- 9.3.3 Drapes or wings that are hung with fullness are depicted as a sine wave with a scaled amplitude of approximately 3" to 6" peak to peak, depending on the degree of fullness.
- 9.3.4 Drapery that is hung with fullness and flown overhead is depicted by a thin uniformly dashed sine wave line of approximately 3" to 6" peak to peak with a vertical thin line at each end.
- 9.3.5 An alternative approach to the flat hung drapery depiction noted in §9.3.1 and §9.3.2 is a low-amplitude sine wave accompanied by a local note "LEGS - FLAT HUNG" or "BORDER - FLAT HUNG."
- 9.3.6 Drops overhead (Painted Borders) should consist of a thin uniformly dashed line and be terminated with a thin line at each end

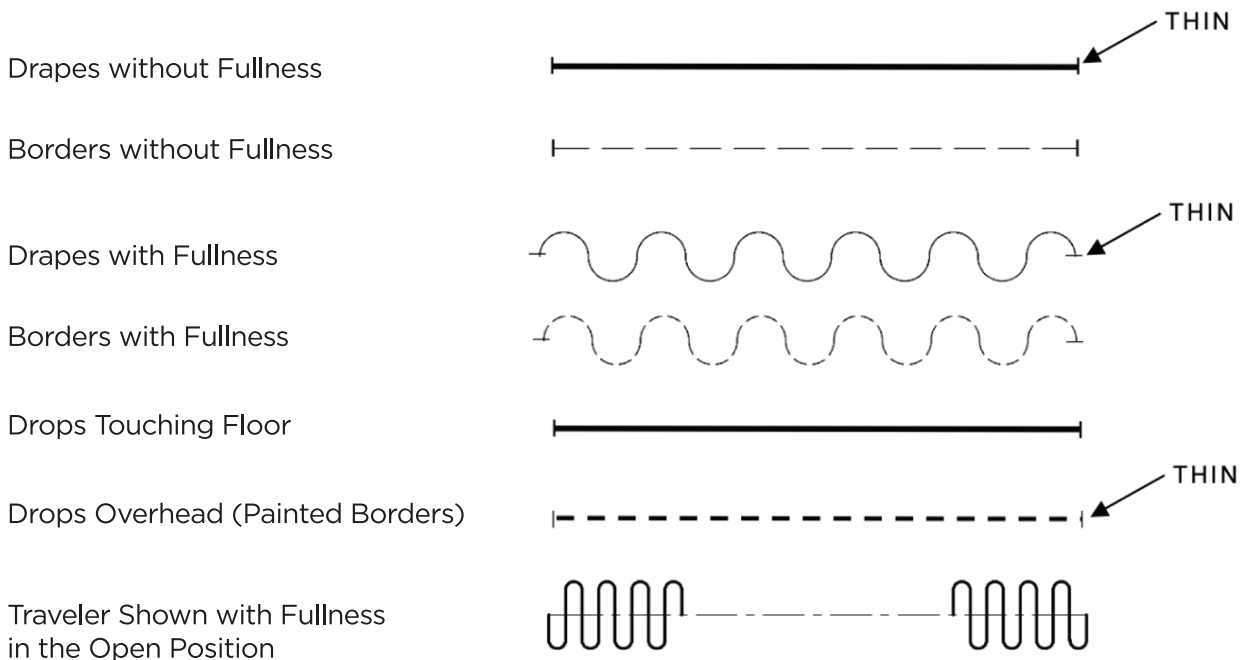

## 10.0 DRAWING AND PLOTTING PRACTICES (CAD)

### 10.1 MODEL SPACE AND PAPER SPACE (SHEET LAYERS)

As a rule of thumb, drafting should be drawn full size in Model Space and plotted in Paper Space. Subsequently, all forms of notation, such as dimensions, notes, detail references, callouts, labels, notes, borders, and title blocks/strips should be generated using the layout function in Paper Space. The scaling of Model Space drawings to fit paper size is done using scaled viewports.

- 9.3.1 Text Height for 1/8" plotted notes created in Model Space seen through Viewports  
 Drapery that is flat hung and flown overhead is depicted by a thin uniformly long dashed line.

Plotted Scale	Text Height in Model Space
1/4"	6"
1/2"	3"
1"	1 1/2"
1 1/2"	1"
3"	1/2"

## 11.0 PLATE NAMING (USE A CLEAR SYSTEM OF ORGANIZATION, IN THE SPIRIT OF WHAT IS SHOWN BELOW)

- All Ground Plans, use **GP**      **GP1** – Act 1 GP      **GP2** – Act 2 GP      **GP3** – Act 3 GP
- All Sections, use **SEC**    **SEC1** – Section Looking SR      **SEC2** – Section Looking SL
- All shop drawings, use:
  - **By category of unit:**    **C1, C2, C3** etc.: (**C** - construction drawing code) or
  - **By type of unit:**    Walls start with **W**, Platforming **P**, Stairs **S**, etc.

## 12.0 FILE MANAGEMENT (CAD)

- 12.1 The full file name should be listed vertically along the left border outside of the drawing area (See § 8.1).
- 12.2 If the full file name is listed on the drawing, the organization should determine the file string order that best meets its own organizational needs.
- 12.3 A suggested file string is depicted below.

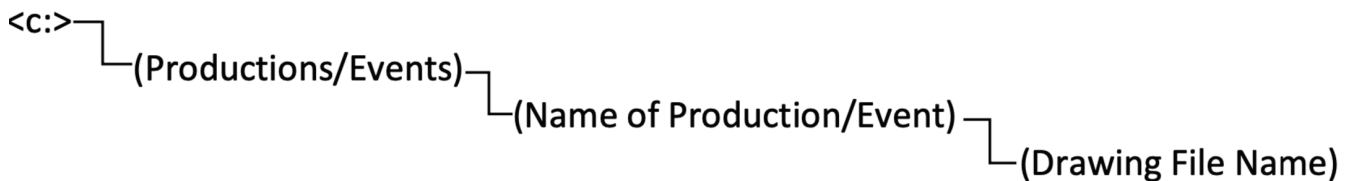

The principal authors of this document, Steven Neuenschwander and Dennis Dorn, would like to thank everyone's efforts in contributing to discussions about drafting and reviewing documentation during the creating of the USITT–GRP.