

SCISSOR LIFT XG1012AC

Comply with AS

Standard configuration

- Withdrawable platform extension with position lock
- Lanyard attach points
- Self-locking half-height swing gate and folding guardrail
- Front-wheel drive
- Travel driven by AC motor
- Full proportion travel and lift control
- 25 % gradeability
- DC maintenance-free battery
- Lubrication-free bearing
- Swing-out component tray
- Brake release for towing
- Emergency stop devices on platform and ground controls
- Anti-slipping metal platform
- Load sensing alarm
- Lowering alarm
- 3-second delay descent
- Multi-axis tilt sensor
- Multi-disc brake
- Scissor maintenance lock
- Auto brake system
- Pothole protection device
- Onboard Diagnostic System
- Electric horn
- Scissor-elevated automatic low speed protection
- Charging protection system
- Removable platform control
- Intelligent charger
- Hourmeter
- Side fork pockets
- Flashing indicator light
- Humanized control system
- Platform control with battery level display
- Manual platform descent valve
- Tilt sensor and audio alarm

Optional configuration

- Platform searchlight
- Platform external power supply
- Air line
- Platform fire extinguisher
- Platform anti-collision device
- Platform foot pedal
- Boom end cover
- PCU protective bracket



Working height
10 meters



Lift capacity
450Kg



Electric
power



XCMG FIRE-FIGHTING SAFETY EQUIPMENT CO.,LTD

No.17 Zhujiang East Road, Hi-Tech Development Zone, Xuzhou, Jiangsu, China
mewp@xcmg.com

XG1012AC



SOLID
TO SUCCEED

Scissor Lift-Electric

Item	Metric
Dimension	
Overall length (without ladder/ outriggers)	2477(2267) mm
Overall width	1170 mm
Overall height (platform folded)	2355 (1805) mm
Platform length	2280 mm
Platform width	1120 mm
Platform extension extension length	900 mm
Guardrail height	1135 mm
Toeboard height	150 mm
Wheelbase	1877 mm
Min. ground clearance (pothole protection deployed/undeployed)	20mm/100mm

Performance	
Max. working height (indoor/ outdoor)	10 m/10 m
Max. platform height (indoor/ outdoor)	8 m/8 m
Min. platform height	1.2 m
Max. platform drive height	8 m
Rated load	450 kg
Load on platform extension	115 kg
Max. platform occupancy (indoor/ outdoor)	2/2
Max. driving speed (stowed)	4 km/h
Max. driving speed (raised)	0.8 km/h
Max. gradeability	25%
Min. turning radius (inside)	0 m
Min. turning radius (outside)	2.3 m
Platform raising time	29-40 s
Platform lowering time	49-60 s
Max. working slope (side to side/ front and rear)	1.5°/3°

Power source	Maintenance-free lead-acid battery
Battery voltage	24 V
Battery capacity (3HR)	200 Ah
Battery charger	24/30 V/A
Traveling motor	0.87/24 kW/V
Lifting motor	3.3/24 kW/V
Hydraulic tank capacity	22 L

Tire	
Tire size	381mm×127 mm
Tire ground pressure	13.3 kg/cm ²
Driving wheels	2
Braking wheels	2
Steering wheels	2

Weight	
Total weight	2680kg

Stowed

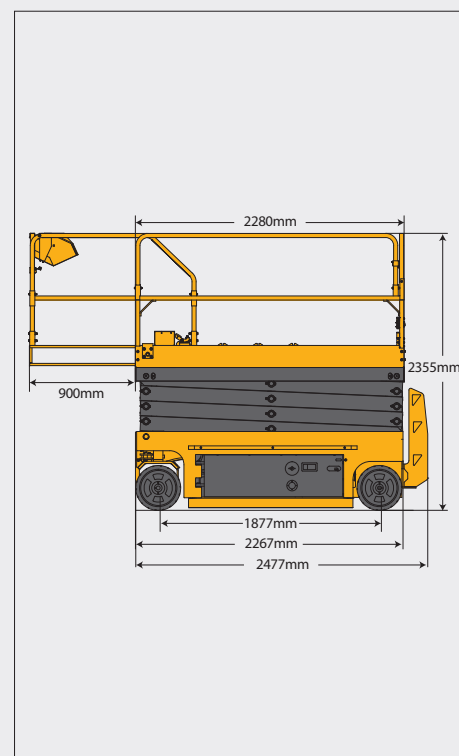

Trans

