



SOLID
TO SUCCEED

AS

ROUGH TERRAIN SCISSOR LIFT

XG1218RT

Comply with AS

Standard configuration

- Foldable guardrail
- Platform self closing gate
- One-way extension platform
- Anti-slipping metal platform
- Scissor maintenance prop
- Pull-out engine tray
- Standard forklift pockets for transport
- Lanyard attach points
- Tie down and lifting points
- 4-wheel drive
- Front-wheel steering
- Motion alarm
- Strobe light
- Electric horn
- Emergency stop button
- Fuel level display
- Full proportion travel and lift control
- Scissor-elevated automatic travel limit protection
- Limit position deceleration and limit protection
- Outrigger leveling system
- Hydraulic oil cooling system
- Tilt protection system
- Auto brake system
- Fault diagnosis system
- Emergency descent system
- Leveling outrigger support detection system
- Engine condition monitoring and start protection system
- Load sensing alarm system
- Axle oscillation system



Working height
12 meters



Lift capacity
455Kg



Diesel
power



Optional configuration

- Scissor-elevated low speed travel
- Non-marking foam-filled tire
- Platform anti-collision
- Platform external power supply

XCMG FIRE-FIGHTING SAFETY EQUIPMENT CO.,LTD

No.17 Zhujiang East Road, Hi-Tech Development Zone, Xuzhou, Jiangsu, China
mewp@xcmg.com

XG1218RT



SOLID
TO SUCCEED

Rough Terrain Scissor Lift-Engine Powered

Item	Metric
Dimension	
Overall length (without ladder/ outriggers)	3835mm(—)
Overall width	1760mm
Overall height (platform folded)	2580(1830)mm
Platform length	2880mm
Platform width	1520mm
Platform extension extension length	1430mm
Guardrail height	1105mm
Toeboard height	150mm
Outrigger span (side to side/ front and rear)	1460mm/3645mm
Wheelbase	2290mm
Min. ground clearance	200mm
Performance	
Max. working height	12m
Max. platform height	10m
Min. platform height	1.43m
Max. platform drive height	1.9m(Standard)/10m(optional)
Rated load	455kg
Load on platform extension	135kg
Max. platform occupancy (indoor/ outdoor)	4/2
Max. driving speed (stowed)	5.0km/h
Max. driving speed (raised)	0km/h(Standard)/0.4km/h(optional)
Max. gradeability	40%
Min. turning radius (inside)	2.3m
Min. turning radius (outside)	4.8m
Platform raising time	38s
Platform lowering time	46s
Max. working slope (side to side/ front and rear)	2°/3°
Outrigger leveling angle (side to side/ front and rear)	/
Power source	
Engine model	Kubota D1105
Engine power/ rpm	18.2kW/(3000r/min)
Max. engine torque	71.5N·m
Hydraulic tank capacity	70L
Fuel tank capacity	48L
Tire	
Tire size	652mm×295mm
Tire ground pressure	12kg/cm ²
Driving wheels	4
Braking wheels	2
Steering wheels	2
Weight	
Total weight	4400kg

Stowed

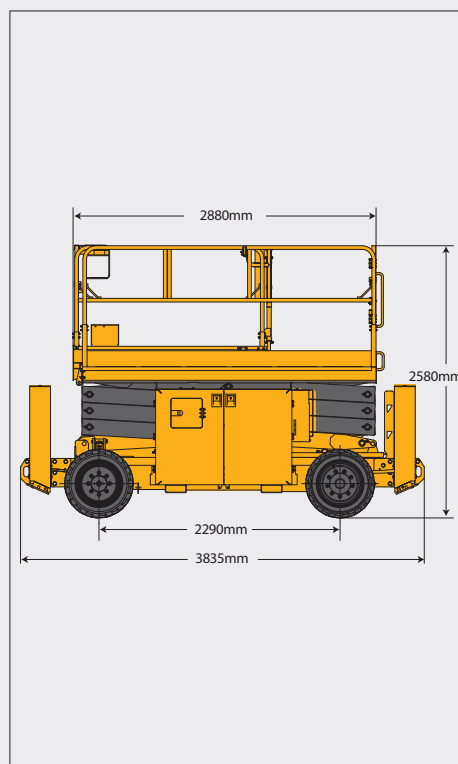

Trans

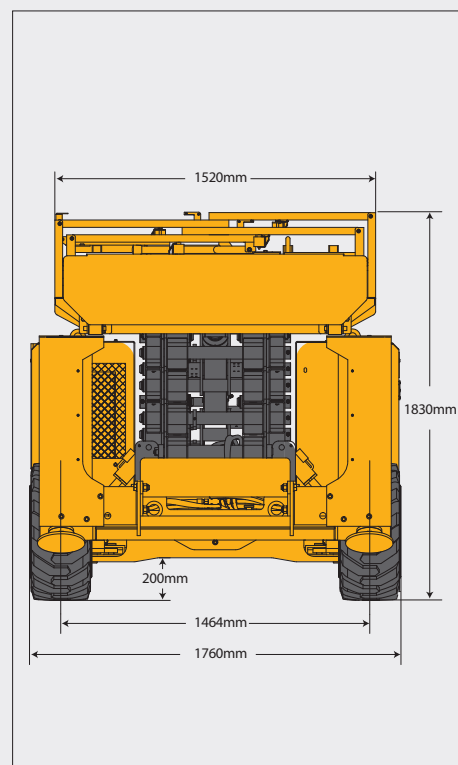

The print does not belong to the contract, nor a part of the commercial contract. We reserve the right to revise the product model, parameters, configuration based on the continuous improvement requirements of the product, without prior notice. Pictures are for reference only, and the specific product shall depend on the real product. The final interpretation rights belong to XCMG.