

XCMG | SOLID
TO SUCCEED

XC9260

WHEEL LOADER

XCMG
SOLID TO SUCCEED



Operating Weight	130000 kg
Engine Rated Power	783 kW
Rated Load	26000 kg
Bucket Capacity	11.5m ³

XC9260 is a self-developed electric drive loader with an operating capacity of up to 26 tons. Designed to focus on reliability, efficiency, intelligence, and easy maintenance, our loader is suitable for various applications, including large open-pit mines, mining truck loading, and short-distance transportation. It is the ideal option for combining with 100 to 130-ton XCMG mining trucks.



PERFORMANCE

Hybrid power and energy recovery, with effective recycling of energy generated by integrated electro-hydraulic braking (EHB) to drive the wheel rim motor enhance energy efficiency and minimize the abrasion of mechanical braking.



SAFETY

Intelligent man-machine interaction system featuring real-time, safe, easy, and fast monitoring and diagnosis of operation as well as the complete safety protection system.



EFFICIENCY

XCMG core technology of “Intelligent electro-hydraulic proportional control system + electrical positive-flow hydraulic system + electrical load-sensing joy-stick steering system” to realize accurate and efficient compound actions during operations including loading, driving, and steering, etc.



RELIABILITY

AC-DC-AC high-voltage electrical-drive system of high efficiency and quick response, featuring special functions of anti-slip, limp home mode, and automatic protection, etc.



PERFORMANCE

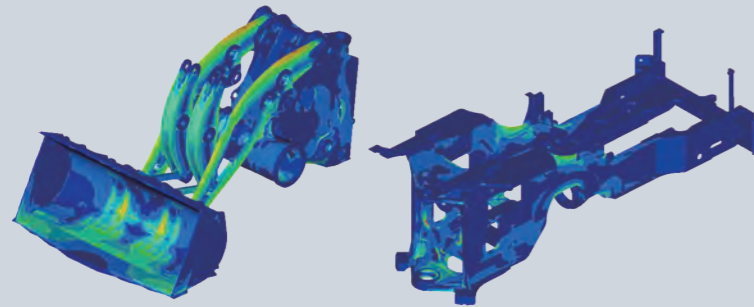

- Structural components by simulation design based on mining conditions, made of low-temperature resistant and high-strength alloy steels, with high-strength casting for critical parts, featuring high loading capacity for torques and impacts under multiple

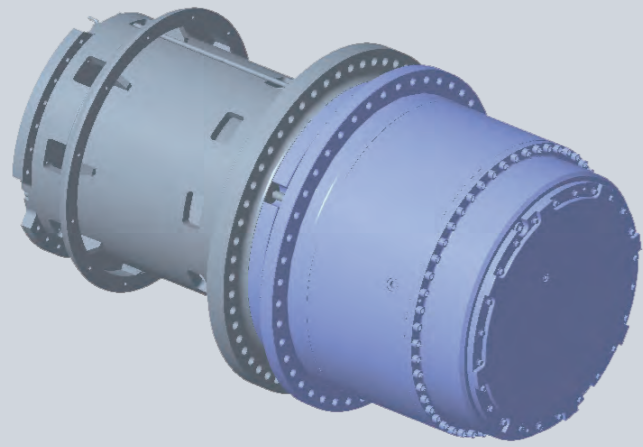

- The hub reducer assembly consisted of multiple-stage planetary wheels featuring a high drive ratio and large torque.
- The three-phase asynchronous motor has the advantages of high reliability, low maintenance rate and high output

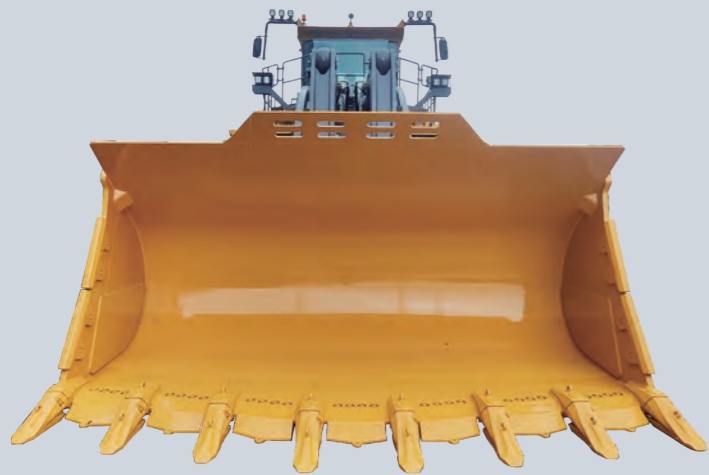

- Utilizing an innovative electric drive transmission system with a highly reliable drive motor eliminates the need for a traditional transmission and drive axle. This design significantly reduces the failure rate



| SAFETY

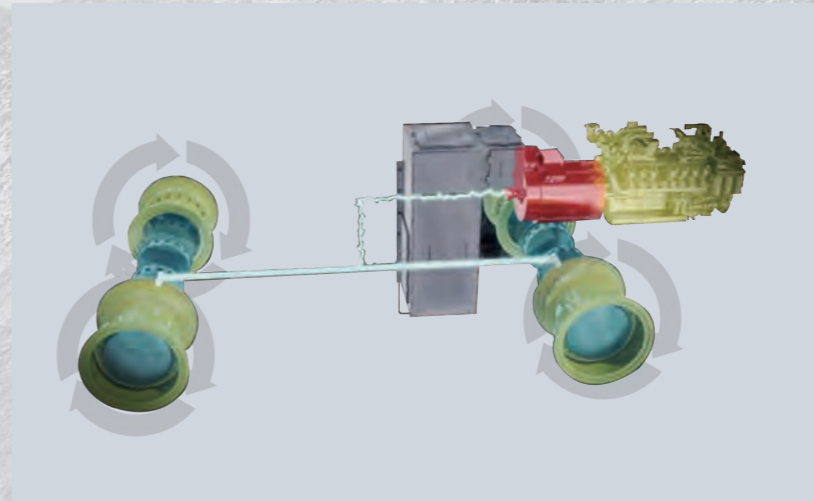

- Hybridization and energy recovery efficiently recover the energy generated by the “integrated electro-hydraulic brake” to power the wheel drive motors, enhancing energy efficiency.

- Perfectly matched engine, generator and wheel drive motor to maximize efficiency and minimize fuel consumption.
- AC-DC-AC electrical drive system offers high efficiency, advanced control technology and fast response, while also providing over 20% fuel conservation compared to other hydraulic-drive loaders.

- The electrohydraulic proportional integrated FNR joystick offers intelligent functions including impact-free operation, automatic positioning, automatic leveling, micro-motion control, and smooth lifting. The load-sensing electronically controlled steering hydraulic system allows for precise machine control, enhancing the operator's comfort.

COMFORT

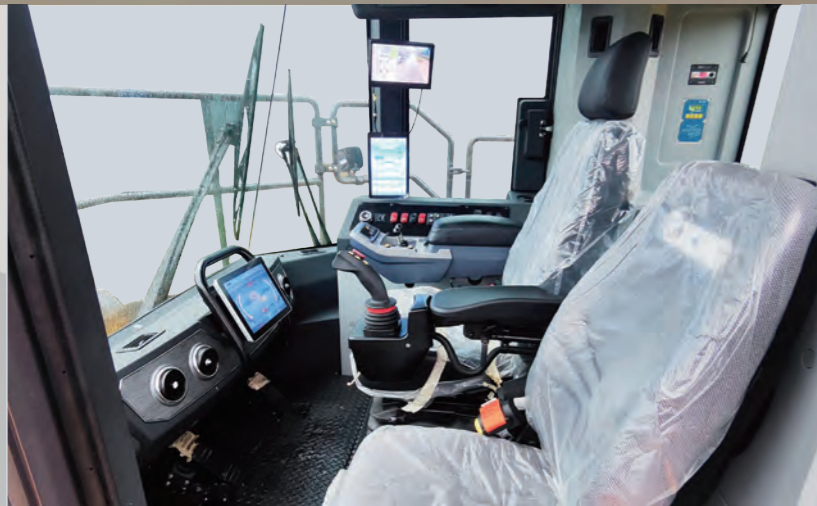

- The XC9 series features a ROPS&FOPS pressurized cab that meets ISO standards.
- Adjustable air-suspension seats with high backrest featuring the streamlined design and shock absorption, configured with dual brake pedals.
- The CAN bus communication technology offers strong resistance to interference. The integrated instrument panel provides precise readings and features audible and visual alarm signals, allowing for real-time monitoring of the machine's operating status.



- Left and right side ladders with emergency access for safety and convenience.
- The ride control ensures the equipment maintains stable operation without external interference.
- The standard emergency steering system activates quickly if the primary system fails, ensuring safe maneuvering of loaders, reducing accident risk and promoting a safe work site.

Priority on backing into operation and braking

L4

Speed and Power limitation

L3

Warning

L2

Reminding

L1

- Twenty-five safety strategies have been developed, categorized into levels L1 to L4, with braking priority set at L4 (highest level). Re-commissioning will be conducted after malfunction to quickly restore power and ensure the electric braking function operates at maximum capacity.



MAINTENANCE



- The machine is configured with multiple platforms and points for maintenance and the hood is designed with various rotary structures for easy maintenance and the least downtime.
- 45° automatic climbing ladder with three-point support for operators makes getting on and off the vehicle safer and more convenient for maintenance and operation.

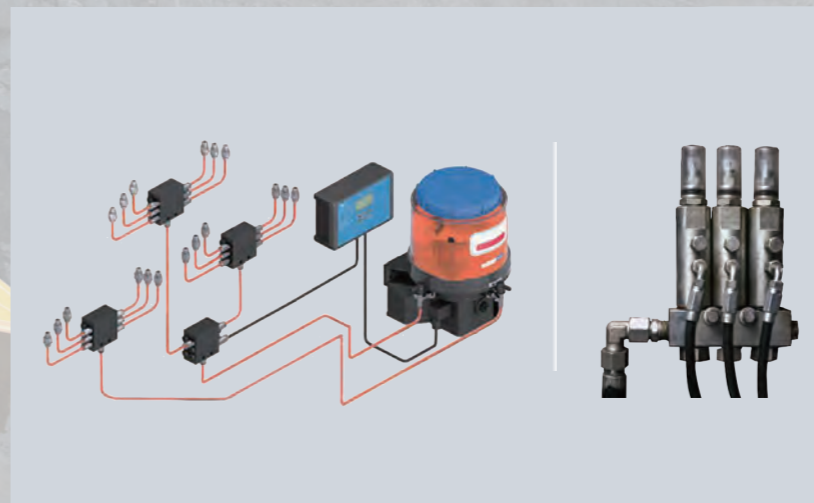

- The centralized lubrication system is to apply greases for articulated points and prevent the failure of the lubrication system due to the blocking of certain lubricating points.
- Integrated pressure test interface of the hydraulic system for easy detection and maintenance.



- Fast filling of fuels, engine oil, and hydraulic oil with high efficiency.
- The centralized sampling of transfer case gear oil, engine oil, and hydraulic oil with easy operation.

MAIN SPECIFICATIONS

Whole Parameters

Model	Parameter
Operating Weight	130000 kg
Rated Load	11.5 m ³
Bucket Capacity	26000 kg
Bucket Breakout Force	≥730 kN
Tipping Load	Straight≥61000 kg
	Fully articulated≥52000 kg

Engine

Manufacturer Model	CUMMINSQST30
Type	Air-to-air intercooler, electronic common rail high-pressure injection
Rated Power	783 kW@2100 RPM
Emission Stage	T2
Displacement	30.5 L

EIC System

Single Rated Output Power	4×220 kW	
Max. Rated Output Torque	4×2334 Nm	
Output Torque	4×4837 Nm	
Travel Motor	Amount	4
	Type	Three-phase asynchronous motor
	Single Rated Output Power	220 kW
Electric Generator	Amount	1
	Type	Brushless excitation generator
	Single Rated Output Power	665 kW

Driveline

Travel Speed	Forward	1st	7.5 km/h
		2nd	12 km/h
		3rd	24 km/h
	Reverse	1st	7.5 km/h
		2nd	12 km/h
		3rd	24 km/h
Speed-Tyre Type	45/65-45		
Wheel Rim Reduction Ratio	95.61		
Braking Distance	8.8 m		
Tyre	45/65-45		
Min. Ground Clearance	486 mm		

Brake

Service Brake	Hydraulically actuated, wet disc brakes actuate on four wheels to ensure great heat dispersion and safe and reliable brake.
Parking Brake	Hydraulically actuated spring-loaded disc brake system on the transmission
Emergency Brake	3 emergency stop switches (1 inside/2 outside) for quick engine shutdown in an emergency.

Hydraulic System

Type	Electronically controlled positive flow system
Pump	Gear pump+ variable-displacement piston pump
Rated Flow	1310 L/min
Control Valve	Electrically controlled bypass valve
System Pressure	30 MPa
Operating Hydraulic Circuit	Lifting circuit for lifting, holding, lowering and staying movable of the boom Tipping circuit for returning, holding and tipping the bucket
Total Circle Time	≤ 17 s

Steering System

Type	Load-sensing, electrically controlled joystick steering
Pump	Load-sensitive pump
Rated Flow	370 L/min
Hydraulic Cylinder	2
System Pressure	24 MPa
Steering Angle	42°

Axle

Drive System	Four-wheel drive
Front Axle	Fixed
Rear Axle	Central oscillation, with 9° angle to each side
Reduction Gear	Planetary final drive in wheel hubs
Differential	Electrical differential

Cab

Cab	ROPS&FOPS Cab; Equipped with heating and cooling air-conditioner, one button start-up, electrically heated rearview mirror; electrically heated air-suspending seat and coach seat.
Heating Power	5.5 kW
Cooling Power	5.5 kW

Sound

Exterior Sound Power Level (Max cooling fan speeds)	111 dB
Sound Pressure Level (ISO 6396:2008)	78 dB
Exterior Sound Power Level (ISO 6395:2008)	106 dB

* The guaranteed sound levels described below may vary depending on factors including operating conditions, cooling fan speeds, engine type, and so on. Hearing protection is required if the operator works in an improperly maintained cab or is exposed to noisy environments with open doors or windows.

Referenced Filling Capacity

*Reference only. Filling volume is based on the actual scale.

Type	Filling capacity
Fuel Tank	2000 L
Engine Oil	114-133 L
Hydraulic Gearbox	22 L
Coolant	400 L
Hydraulic Oil	820 L
Reduction Gear	48 L×4

MAIN SPECIFICATIONS

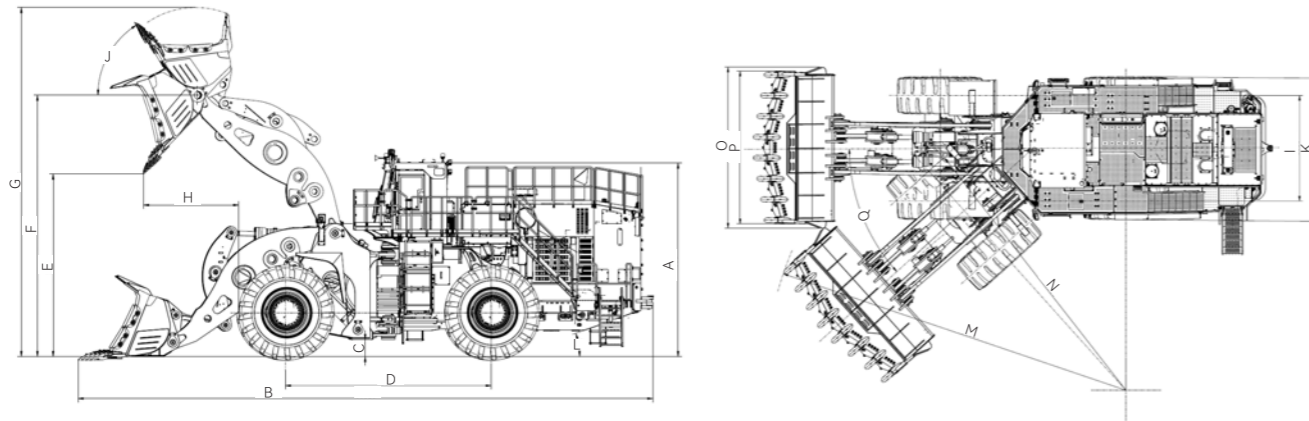

	Dimension and Specification	Parameter
A	Height to top of cab	5537 mm
B	Overall length	16323 mm
C	Ground clearance	486 mm
D	Wheelbase	5900 mm
E	Dumping height	5229 mm
F	Height to hinge pin, fully raised	7485 mm
G	Max. lifting height	9978 mm
H	Dumping reach	2607 mm
I	Wheel track	3350 mm
J	Rollback angle	60°
K	Width over tyres	4498 mm
L	Departure angle	19°
M	Turning radius: over bucket	11354 mm
N	Turning radius: over tyres	9360 mm
O	Bucket width	5107 mm
P	Bucket width	4844 mm
Q	Steering angle	42°

- The technology of XCMG wheel loaders is subject to constant improvement and upgrading. In case the specifications or detailed appearance contained in this brochure differ from actual products, the latter shall prevail.
- XCMG reserves the right of final interpretation for the above. Our products may be modified without prior notice to users.

EQUIPMENT

Powertrain	STD	OPT
Four-wheel independent drive, electrical differential	●	
Electrical brake-hydraulic brake	●	
50° temperature heat dissipation	●	
Enlarged radiator	●	
Independent dissipation with temperature-controlled fan	●	
Heavy/ medium/ light-duty mode	●	
45/65-45 Takayin bias-ply tyre	●	
Michelin meridian tyre 45/65R45		●
Emergency steer	●	
Automatic brake	●	
Fast filling system <small>(fuel/ transmission oil/ hydraulic oil/ engine oil/ lubricating grease)</small>	●	

Electrical system	STD	OPT
Rotating warning light	●	
Man-machine interacted LED display terminal	●	
Video monitoring system (TF card)		●
Electrically heating rearview mirror		●
Battery (low-temperature resistance)	●	
Stair light	●	
24V power interface	●	
Speed display	●	
Sub-starter outlet	●	
Battery preheating		●
Fuel preheating		●
Coolant preheating		●
Hydraulic oil preheating		●
Electrically weigh	●	
Electrically heated engine oil		●
Auto-drive heating		●
Electrical FNR steering joystick	●	
Back warning	●	

Hydraulic system	STD	OPT
Variable hydraulic system	●	
Load-sensing system	●	
Flow amplifier	●	
Manual unloading switch	●	
Fan (hydraulic drive)	●	
Intelligent shoveling <small>(auto-leveling/auto-locating/buffering function/ micro-action)</small>	●	

CAB	STD	OPT
FOPS&ROPS cab	●	
Electric dual control handle	●	
Air-conditioner (high cooling capacity)	●	
Air-suspending and electrically heated seat with high backrest	●	
Rear defroster (air-conditioner)	●	
Two-point retractable safety belt	●	
Rear wiper	●	
Sun visor	●	
Stereo	●	
Coach seat	●	
Dust proof air-conditioner	●	
Pressurized cab	●	
Bluetooth radio	●	
Membrane switches	●	
Joystick steering	●	
Three-point retractable safety belt		●
Windshield laminated glass	●	

Safety	STD	OPT
Extinguisher		
360° panoramic view	●	
Low-temperature resistance high tensile steel plate	●	
GPS malfunction monitor terminal	●	
Battery isolation switch	●	
Start-up isolation switch	●	
3 emergency brake switch	●	
Emergency ladder	●	
Automatic fire extinguishing system	●	

Bucket	STD	OPT
13m³ rock shovel bucket		●
14.5m³ rock shovel bucket		●

Other	STD	OPT
Tyre chains		●
Complete set of oil for low-temperature condition		●
Chassis guard	●	
Rear tyre mud baffle	●	
Light guard	●	
Parking module		●
Centralized sampling	●	
Automatic centralized lubrication	●	

OPTIMUM SERVICES XCMG GUARANTEED



Telematic Information Processing

Remote Diagnosis. GPS terminal system monitors the construction state of the machine and the operating.



Professional Integrated Complete Solutions

XCMG has built a strong reputation based on the quality, reliability and durability of its construction machinery. What's more, XCMG has gradually established a service network to constantly provide its local integrated and highly efficient complete solutions for all customers.



Full Range of Services Ready for you

In order to respond to your needs as fast as possible, XCMG's experts are on their way to your job site from one of our facilities near you. Full range of services are available in order to reduce your total cost of ownership and increase your revenue.



Plateau Construction



Forestry Construction



Animal Husbandry



Road Construction



Stone Mining



Extreme Cold Working Condition



Mine Engineering



Grain Shoveling

INTRODUCTION

Our Mission and Vision: Empower Solid Future.

Founded in 1943, XCMG is a multinational corporation with the most comprehensive range of competitive, influential products in the construction machinery industry. Our mission is to Empower Solid Future by providing complete sets of engineering equipment and solutions for global customers. It is the enterprise with the most complete categories and complete sets in the world's construction machinery industry. As of now, XCMG has retained its No.1 position in China's construction machinery industry for 35 consecutive years and is ranked NO.3 in the global construction machinery industry. Today, we sell products in over 190 countries and regions worldwide. We drive enterprises to smart, sustainable, and efficient solutions through technological innovation and excellent management solutions.

XCMG Earthmoving Machinery Business Division is a core machinery R&D and manufacturing enterprise under XCMG, specializing in the research and development, manufacturing, and sales services of a full range of loaders from 0.4 to 35 tons, including new energy loaders, skid-steer loaders, and backhoe loaders. It is the first enterprise in China and the third globally to possess the production capacity of loaders with a loading capacity exceeding 35 tons. For 35 consecutive years, it has maintained its position as the top loader exporter in China. XCMG Earthmoving Machinery Business Division has always adhered to the core values of "Responsibility, Virtue, and Fortitude." XCMG perseveres through challenges and forges ahead with determination!

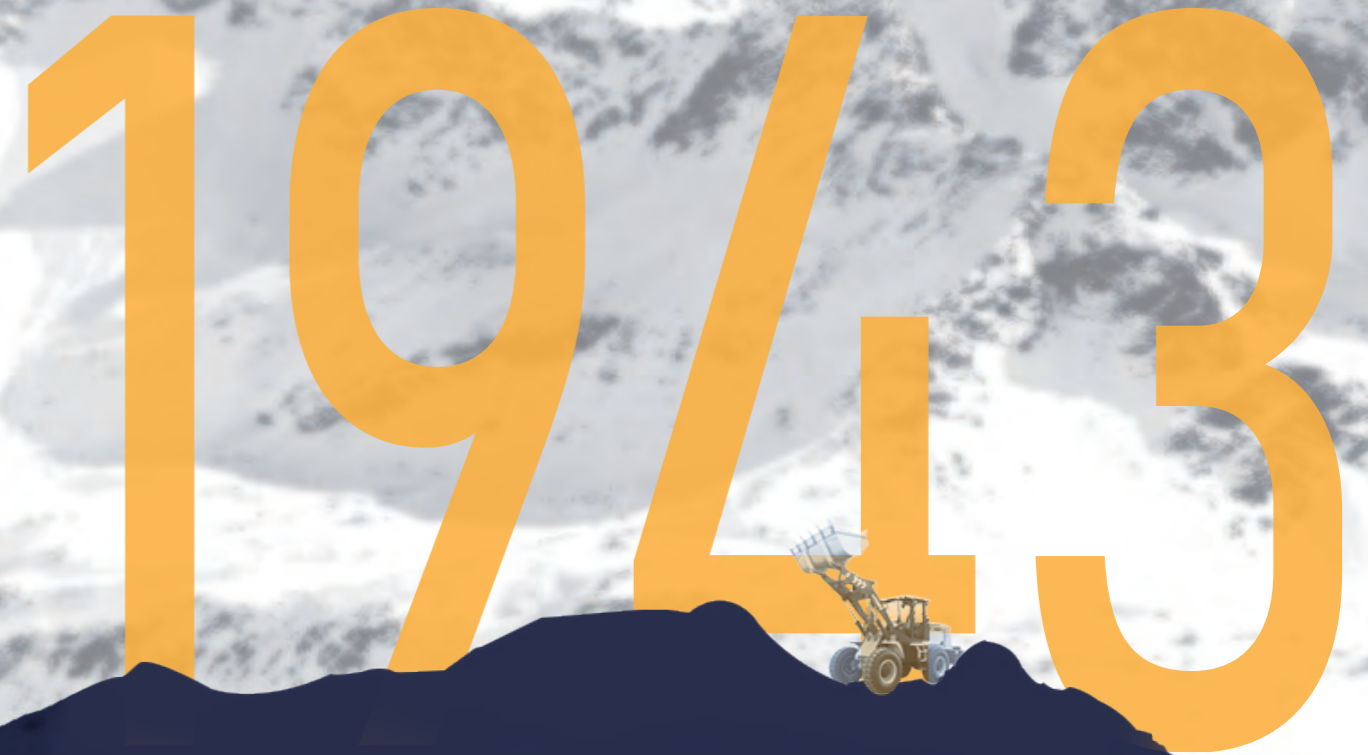

1943

2000+

Overseas Service & Parts Center

330+

Overseas Dealer

40+

Overseas Office

30+

Overseas Company

10+

Overseas Manufacturing
Base & KD Factory

5+

Overseas R & D Center