

COMPACT TRACK LOADER

XC7-TV10





INTRODUCTION OF XCMG

XCMG was initially founded as the Huaxing Iron Factory in 1943 and was established as a group in 1989. Being a trailblazer walking through the hard days in a stern and steady manner, XCMG has taken the lead in the development of Chinese construction machinery industry and become a billion-dollar leading enterprise with global competitiveness and influence. XCMG's performance retained its NO.1 position in China construction machinery industry and has achieved the ranking of NO.3 in the Global construction machinery industry for 3 consecutive years and has been listed in the "World Brand 500" for 4 consecutive years.

XCMG Earthmoving Machinery Division is one of the five major business divisions of XCMG. We are professionally dedicated in the R&D, manufacturing, sale and supporting service of 0.6-35 tons full-series loaders, skid-steer loaders and backhoe loaders. In line with the business philosophy of facing the world, integrating the world and serving the world, XCMG Earthmoving Machinery Division takes the leading position in quality and value, and become the new benchmark in the high-end market of China earthmoving machinery industry.



OVERVIEW

YANMAR ENGINE

The Yanmar engine provide a output 61.3kW. With unmatched performance. The engine is Tier III certified.

CAB

The machine is designed with ROPS/FOPS certified cab. Suspension seat provide greater comfort for the operator, EH Control is standard with ISO/H control mode.

POWER TRAIN

The hydrostatic Transmission provides quick travel Response and aggressive drive. Two speed is standard With hydraulic released parking brakes

Hydraulic System

Equipment with axial-piston hydrostatic pump minimizes Hydraulic loss for better fuel economy by delivering as much as flow as need. High flow and third function valve are standard for work tool attachments.

VERSATILITY

The quick coupler and third function hydraulic are standard, can be easily and quickly switching between a range of attachments. Beside, the coupler is designed as ISO standard compatible with a wide range of attachments.



Comfortable operation surrounding



— All day long comfort

The spacious interior cab designed helps the operator comfortably and productively all the day. The suspension seat provides further comfortable and less fatigue environment. The pressurized cab provides cleaner and quieter working environment.

— Four- season comfort

Air-conditioning is standard equipment on The TV10, the cab is designed with optimized Ducts and vents to maximize airflow. AD filter easily replaced.

— Easy to operate

Joysticks are equipped with ISO/H mode, ISO or H patterns can be easily activated, adapting to



— High Resolution Machine Monitor

The color monitor can display working hour, temperature, fuel level, maintenance information and much other information.



No Compromise On Safety

— ROPS&FOPS Cab

ROPS (Rollover Protective System) and FOPS (Falling Object Protective Structure) are standard equipment to protect operator. The ROPS and FOPS cab is certified, satisfy with ISO standard.



— Rearview camera

The standard rearview camera is available on the TV10 to see the jobsite behind the machine, keep Harms away. The rear camera integrate seamless Into display.



— Interlock System

The front door of cab is the first interlock. Which prevents the boom lifting unless closed. The armrest is the second interlock starting Engine after down, help keep harm's way at Bay.

Maintenance Make Easy



— Ground level access

Rear door and AC cooler core swing out easily, Hydraulic drive cooling system, radiator fixed up on the top provide excellent serviceability. Ground-level access to daily service, the engine fuel and air filters on the right side are easier to change. The engine oil filter and fuel-water separator on the left side are Readily accessible.

— Maintenance easy

The cab swings up more than 80 degrees, designed to access to the machine systems and easy replacement of the hydraulic key components and filter.





— Quick Coupler and attachments

Our quick coupler is designed as ISO Standard which is widely used, the standard quick coupler allows one machine to use a series of attachments, give you business greater versatility. Compact track loader are compatible with buckets, brooms, hydraulic hammers, augers, forks, bale huggers, dozer blades and other attachments.



Technical Specifications

XC7-TV10	
Rated load	≥1100 kg
Tipping load	≥3143 kg
Operating weight	4750±100 kg
Maximum digging force	28.5±2kN
Maximum traction force	28.5±2kN
Maximum lifting capacity	3765 kg
Rated Power	61.3 kW
Emission	Tier III
Rated speed	2500 rpm

Performance

Operation	Electric hydraulic proportional control
Track specifications	400×86BC
Single speed/Dual speed	9±1/14±1km/h
Operating weight	4750±100 kg

Hydraulic system

Flow	80 L/min
Hydraulic flow rate (combined flow state)	120 L/min
Hydraulic pressure	230±10 bar
Cycle time	≤14 s

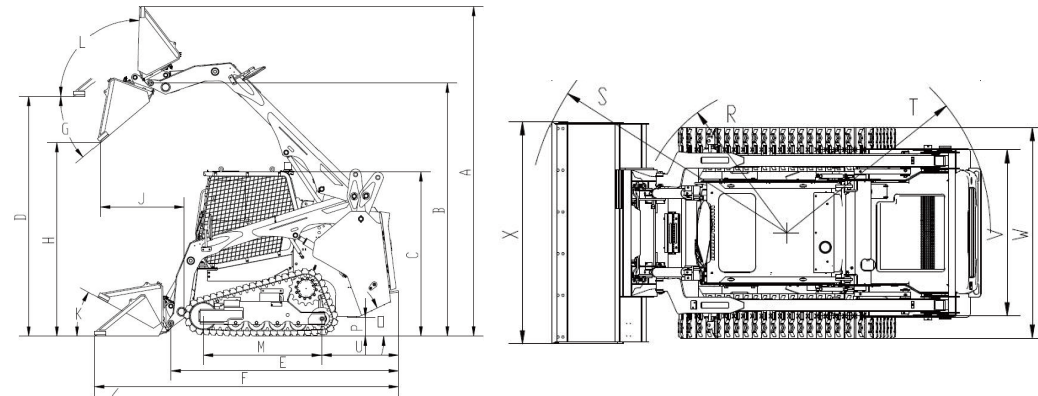

A	Max operation height	4188mm
B	Hinge pin height	3214mm
C	Top height of the cab	2088mm
D	Bucket bottom max height	3047mm
E	Length without bucket	2880mm
F	Length with bucket	3851mm
G	Maximum bucket dump angle	40°
H	Dumping height (Max dump angle)	2461mm
J	Dumping reach (Max dump angle)	1059mm
K	Rollback angle at ground	29.1°
L	Bucket rollback angle Max height	91.5°
M	Track grounding length	1498mm
O	Departure angle	25.5°
P	Ground clearance	215mm
R	Front Turning radius(no bucket)	1348mm
S	Front turning radius(with bucket)	2336mm
T	Rear turning radius	1829mm
U	Rear length	927mm
V	Wheel tread	1496mm
W	Width over tracks	1896mm
X	Max Width(bucket)	2000mm
	Bucket capacity (stack height)	0.6m ³
	Bucket capacity	0.47m ³
	Fuel Tank	105L
	Hydraulic tank	50L

Optimum Services , XCMG Guaranteed



XCMG approved attachments



Genuine parts



Financial solutions



Maintenance contract



Full Range of Services Ready for You

In order to respond to your needs as fast as possible, XCMG experts can be dispatched to your job site from a facility near you. A full range of services are available to reduce your total cost of ownership and increase your revenue.

XCMG Global Spare Parts System



Professional Integrated Complete Solutions

XCMG group has built a strong reputation based on the quality, reliability and durability of its construction machinery. XCMG has established a world wide service and parts network to provide support to every customer regardless of location.



Mobile cranes



Excavators



Aerial work platforms



Wheel loaders



Road machinery



 **XCMG**

