

COMPACT TRACK LOADER

XC7-TV12





INTRODUCTION OF XCMG

Founded in 1943, XCMG is a multinational corporation with the most comprehensive range of competitive, influential products in the construction machinery industry. Our business covers eight key areas: construction machinery, heavy trucks, mining machinery, sanitation machinery, machinery components, construction, finance, and the ICT industry.

XCMG has established a global R&D network with a total of six centers in China, the US, Germany, Brazil and India, with China national technology center at its core. In addition to a number of manufacturing bases in China, the US, Germany, the Netherlands, Poland, Austria, Brazil, India, and Uzbekistan, we possess two complete machine brands (XCMG, Schwing), and several component brands including FT, AMCA. It is the strength of this global R&D network and manufacturing operations that has made XCMG the industry leading global construction equipment manufacturer that it is today.



OVERVIEW

YANMAR ENGINE

The Yanmar engine provide a output
61.3kW With unmatched
performance.

CAB

The machine is designed with ROPS/FOPS certified cab.
Suspension seat provide greater comfort for the operator,
EH Control is standard with ISO/H control mode.

POWER TRAIN

The hydrostatic Transmission provides quick travel
Response and aggressive drive. Two speed is standard
With hydraulic released parking brakes

Hydraulic System

Equipment with axial-piston hydrostatic pump minimizes
Hydraulic loss for better fuel economy by delivering as
much as flow as need. High flow and third function valve
are standard for work tool attachments.

VERSATILITY

The quick coupler and third function
hydraulic are standard, can be easily
and quickly switching between a range
of attachments. Beside, the coupler is
designed as ISO standard compatible
with a wide range of attachments.



Comfortable operation surrounding



— All day long comfort

The spacious interior cab designed helps the operator comfortably and productively all the day. The suspension seat provides further comfortable and less fatigue environment. The pressurized cab provides cleaner and quieter working environment.

— Four- season comfort

Air-conditioning is standard equipment on The TV12, the cab is designed with optimized Ducts and vents to maximize airflow. AD filter easily replaced.

— Easy to operate

Joysticks are equipped with ISO/H mode, ISO or H patterns can be easily activated, adapting to



— High Resolution Machine Monitor

The color monitor can display working hour, temperature, fuel level, maintenance information and much other information.



No Compromise On Safety

— ROPS&FOPS Cab

ROPS (Rollover Protective System) and FOPS (Falling Object Protective Structure) are standard equipment to protect operator. The ROPS and FOPS cab is certified, satisfy with ISO standard.



— Rearview camera

The standard rearview camera is available on the TV12 to see the jobsite behind the machine, keep Harms away. The rear camera integrate seamless Into display.



— Interlock System

The front door of cab is the first interlock. Which prevents the boom lifting unless closed. The armrest is the second interlock starting Engine after down, help keep harm's way at Bay.

Maintenance Make Easy



— Ground level access

Rear door and AC cooler core swing out easily, Hydraulic drive cooling system, radiator fixed up on the top provide excellent serviceability. Ground-level access to daily service, the engine fuel and air filters on the right side are easier to change. The engine oil filter and fuel-water separator on the left side are Readily accessible.

— Maintenance easy

The cab swings up more than 80 degrees, designed to access to the machine systems and easy replacement of the hydraulic key components and filter.





— Quick Coupler and attachments

Our quick coupler is designed as ISO Standard which is widely used, the standard quick coupler allows one machine to use a series of attachments, give you business greater versatility. Compact track loader are compatible with buckets, brooms, hydraulic hammers, augers, forks, bale huggers, dozer blades and other attachments.





Technical Specifications

ENGINE

Yanmar China III emissions certified	
Model	4TNV98T-ZCNTYBC
Type	Water-cooled, 4-cycle
Aspiration	Turbocharged & air-to-air intercooled
Number of cylinders	4
Displacement	3.319L
Gross power	61.3kW 2500r/min
Peak torque	269~293 N·m/1625±25 r/min
Fuel system	Direct injection
Air cleaner	dry type with double elements

COOLING

Fan drive	Hydraulically driven
-----------	----------------------

POWER TRAIN

The hydrostatic Transmission provides quick travel response and aggressive driven.		
Travel speed	Forward	Reverse
1st	8 km/h (5mile/h)	8 km/h (5mile/h)
2nd	14 km/h (8.75mile/h)	14 km/h (8.75mile/h)

HYDRAULIC SYSTEM

System type	Variable driving and working hydraulic system,EH Joystick
Pump Flow, Standard	57 ml/r
Traveling pressure	35MPa
Raise time	≤5.5 s
Dump time	≤2 s
Lower time(empty)	≤3.5 s
Total cycle time	≤11 s

ELECTRICAL

Voltage	12 V
Battery capacity	95AH
Alternator rating	12V/80A

REFILL CAPACITY

Cooling system	40 L	10.57 gal
Fuel tank	105 L	27.74 gal
Engine oil	9.4 L	2.48 gal
Hydraulic tank	40 L	10.57 gal
Hydraulic system total	53 L	14.0 gal
Chain box, each side	/	/

PERFORMANCE

Operating weight	5150kg±50	
Rated operating capacity	≥1360kg	≥2992lb
Boom breakout force	≥28KN	≥6300lbf
Bucket breakout force	≥33KN	≥7425lbf

NOISE LEVEL

Inside cab	≤81dB
Outside cab	≤103dB

Technical Specifications

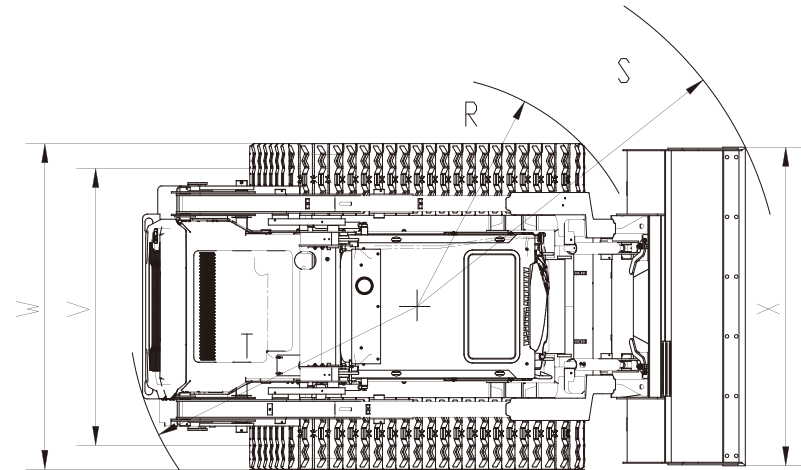
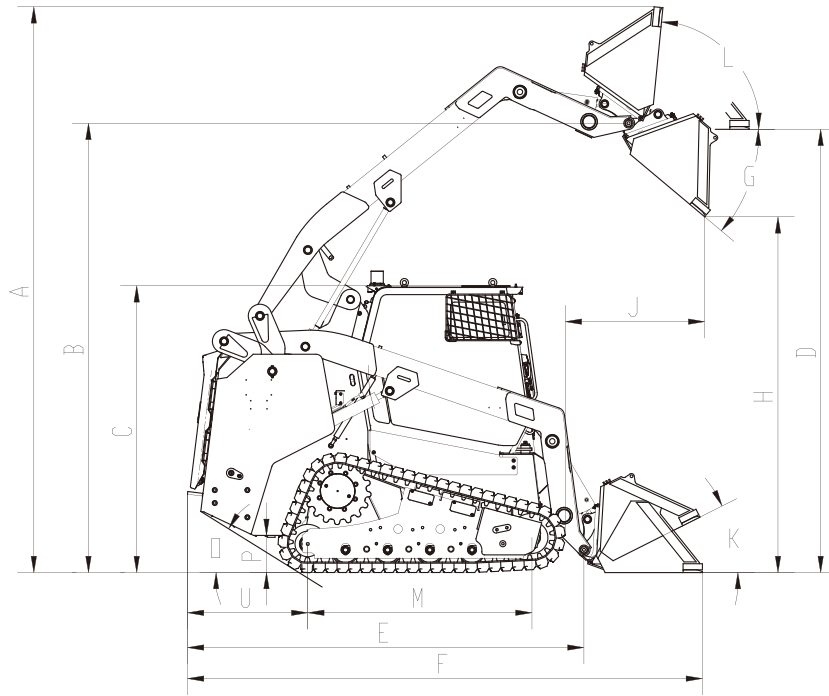

DIMENSIONS

A Maximum overall height	4160mm
B Height to hinge pin at maximum lift	3300 mm
C Height to top of cab	2100 mm
D Clearance bucket bottom to ground	3136 mm
E Length without bucket	2915 mm
F Length with bucket	3786 mm
G Dump angle (full lift height)	40°
H Dump height at maximum lift and dump	2615 mm
K Bucket rollback at ground level	26°
L Full rotation angle of bucket at the highest point	84°
J Reach at maximum lift and dump	1025 mm

M Wheelbase	1640 mm
O Angle of departure	31°
P Ground clearance	216 mm
R Front turning radius without bucket	1468 mm
S Front turning radius with bucket	2293 mm
T Rear turning radius	1806 mm
U Bumper overhang behind Rear Axle	885 mm
V Tread	1595 mm
W Width without bucket	2045 mm
X Width bucket	2130mm

STANDARD EQUIPMENT

ENGINE

Yanmar, CHINA III emissions, 4 cylinder 4 stroke

Electronic injection system

COOLING

Hydraulically driven

POWERTRAIN

Two speed travel

Hydrostatic transmission

Closed-center hydraulic

Hydraulic released parking brakes

HYDRAULIC

Axial-piston hydrostatic pump

EH control

H/ISO mode joysticks

Third function valve standard

Standard hydraulic flow 95L/min

Maximum hydraulic flow 142.5L/min

OPTIONAL EQUIPMENT

Ride control

Additional counterweight

ELECTRIC

Four LED lights

Battery

Backup alarm

Electric horn

Rotating beacon

Front windshield wiper

TRACK

450-86-56

LINKAGE& ATTACHMENT

Vertical lift linkage

Quick coupler standard

ISO standard interface

BUCKET

0.6m³(0.78yd³)

CAB

ROPS/FOPS cab

Adjust seat with suspension

Armrest and control interlock

Air conditioning

Rearview mirror

Fire extinguisher

Retractable seat belt

Rearview camera

OTHER

Hour meter

Voltage

Coolant temperature

Hydraulic oil level sight gauge

Coolant level sight gauge

Engine oil temperature

Engine oil pressure

Hydraulic oil temperature

Optimum Services , XCMG Guaranteed



XCMG approved attachments



Genuine parts



Financial solutions



Maintenance contract



Full Range of Services Ready for You

In order to respond to your needs as fast as possible, XCMG experts can be dispatched to your job site from a facility near you. A full range of services are available to reduce your total cost of ownership and increase your revenue.

Professional Integrated Complete Solutions

XCMG group has built a strong reputation based on the quality, reliability and durability of its construction machinery. XCMG has established a world wide service and parts network to provide support to every customer regardless of location.

XCMG Global Spare Parts System



Mobile cranes



Excavators



Aerial work platforms



Wheel loaders



Road machinery



 **XCMG**

