



# XE27U

CRAWLER EXCAVATOR



SOLID TO SUCCEED



Operating weight 2780kg

Bucket capacity 0.06m<sup>3</sup>

Rated power 18.2kW

## XCMG European Sales and Services GmbH

Europark Fichtenhain B4, 47807 Krefeld, Germany

Email : info@xcmg-ess.de

Ref. U/OA/AC/27/English/2025-04/01

Materials and specifications are subject to change. All rights reserved without prior notice.

Featured machines in photos may include additional equipment. See your local dealers for more details.



WWW.XCMGGLOBAL.COM  
XCMG OFFICIAL WEBSITE



# SOLID TO SUCCEED

**Applications :** Municipal construction, landscaping, farmland water conservancy.

**Features :** High power engine with strong power; equipped with heating and cooling air conditioning, comfortable operations; with quick coupler and two auxiliary pipelines, adjustable pressure and flow rate, suitable for various attachments such as tilting buckets and thumb.

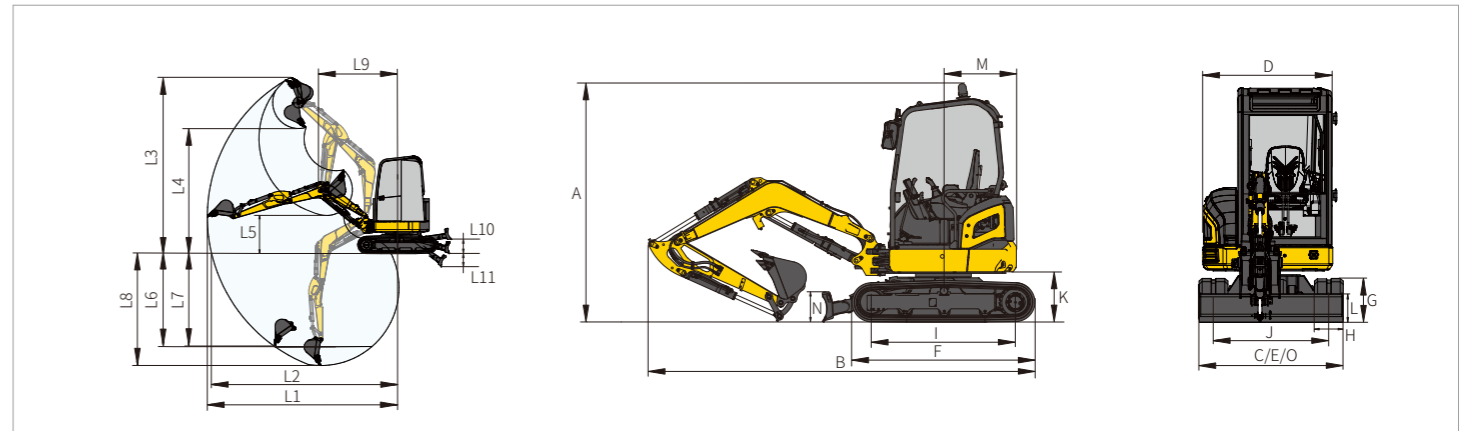

Never attempt to lift or hold any load in excess of the rated lifting capacity at the specified lifting radius and height. The lifting point is located on the lifting eye of the arm (Bucket weight is not included), any additional attachment such as bucket should be deducted from the lifting weight. When determining the net lifting weight allowed for the machine, the weight of the slings and any auxiliary lifting devices must be deducted from the rated lifting capacity. Lifting capacity is based on the machine standing on firm and level ground. The operator should consider working conditions such as soft or uneven ground. Before operating the machine, the operator should familiarize himself with the safety procedures in the relevant manual.

		kg										Dozer Blade up	
		In travel direction					Against travel direction					Right angle to travel direction	
LD	Y	1.0m		2.0m		3.0m		4.0m		MAX		m	
		X		X		X		X		X			
1.3m	Z2					*435	360			402	290	3.37	
	Z1			791	525	430	298	294	207	282	198	4.10	
	Z3	990	990	*596	527	425	294			350	244	3.47	

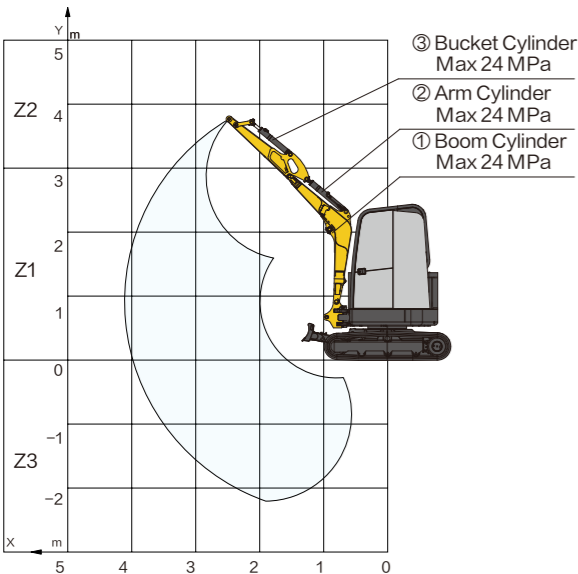

Note 1 The lifting capacities in the table refer to the case where no external thrust intervention is included.  
 Note 2 Lifting capacities marked with an asterisk (\*) in the table are limited by hydraulic capacity and should not exceed 75% of the minimum tipping load or 87% of the hydraulic capacity.  
 Note 3 The least stable position is on the side of the excavator.  
 Note 4 The lifting capacity table applies only to machines originally built and normally assembled by the manufacturer.  
 Note 5 The machine is rated for an Operating mass of 2780 kg ( 6129 lb ), which includes 0.3 m ( 0.98 ft ) rubber tracks, a 2.09 m ( 6.86 ft ) boom, a 1.3 m ( 4.27 ft ) arm, a 300 kg ( 661.3 lb ) counterweight, all working fluids, and a 75 kg ( 165 lb ) operator, exclusive of the bucket.  
 Note 6 Lifting capacity shall be in accordance with ISO 10567:2007.  
 Note 7 For all configurations of track specifications, the lifting capacity is kept within ±5%.

Item contents	Unit	Parameters
<b>Working range</b>		
L1	Maximum reach	mm 4750
L2	Maximum reach at GRP	mm 4640
L3	Maximum digging height	mm 4390
L4	Maximum unloading height	mm 3210
L5	Minimum unloading height	mm 955
L6	8 ft. level floor digging depth	mm 2312
L7	Maximum vertical digging depth	mm 2310
L8	Maximum digging depth	mm 2800
L9	Minimum swing radius	mm 1980
L10	Maximum lifting height of dozer blade	mm 310
L11	Max. cutting depth of dozer blade	mm 330
	Boom deflection angle (left)	- 72°
	Boom deflection angle (right)	- 55°

Item contents	Unit	Parameters
<b>Dimensions</b>		
A	Overall height	mm 2620
B	Overall length	mm 4225
C	Overall width	mm 1500
D	Upper structure width	mm 1350
E	Chassis width	mm 1500
F	Track length	mm 1980
G	Track height	mm 455
H	Standard track shoe width	mm 300
I	Track wheelbase	mm 1560
J	Track gauge	mm 1200
K	Counterweight ground clearance	mm 528
L	Minimum ground clearance	mm 290
M	Tail Swing Radius	mm 790
N	Dozer blade height	mm 300
O	Dozer blade width	mm 1500

Item contents	Unit	Parameters
Operating weight	kg	2780
<b>Engine</b>		
Engine brand/model	-	Kubota/D1305
Rated power/rpm	kW/rpm	18.2/2400
4-stroke	-	√
Water-cooled	-	√
Stroke	mm	88
Cylinder bore	mm	78
Number of cylinders	-	3
Maximum torque/rpm	Nm/rpm	81.3/1600
Displacement	L	1.261

Item contents	Unit	Parameters
<b>Hydraulic system</b>		
Main pump	-	One variable pump
Maximum flow rate of main system	L/min	82.8
Main system pressure	MPa	24.3
Pilot system pressure	MPa	3.5
Travel system pressure	MPa	24.3
Swing system pressure	MPa	21

Item contents	Unit	Parameters
<b>Oil capacity</b>		
Fuel tank capacity	L	38
Hydraulic oil tank capacity	L	22

Item contents	Unit	Parameters
<b>Main performance</b>		
Travel speed ( high/low )	km/h	4.0/2.1
Swing speed	r/min	10
Maximum swing torque	kN-m	3.5
Gradeability	-	30° ( 58% )
Ground specific pressure	kPa	26.4
Bucket digging force (ISO)	kN	23
Arm digging force (ISO)	kN	14
Maximum traction force	kN	29.7

Item contents	Unit	Parameters
<b>Track</b>		
Standard track shoe width	mm	300
Number of track roller (per side)	-	3
Number of track carrier roller (per side)	-	1

Item contents	Unit	Parameters
<b>Standard</b>		
Length of boom	mm	2090
Length of arm	mm	1300
Bucket capacity	m <sup>3</sup>	0.06 ( Earthmoving bucket )

Item contents	Unit	Parameters
<b>Cab standard</b>		
ISO 10262: 1998 ( OPG )	-	√
ISO 12117: 1997 ( TOPS )	-	√
ISO 3471: 2008 ( ROPS )	-	√

Item contents	Unit	Parameters
<b>Optional</b>		
Length of boom	mm	-
Length of arm	mm	-
Bucket capacity	m <sup>3</sup>	0.026 ( Earthmoving bucket ) 0.13 ( Ditch cleaning bucket )