





XDE200

Haul Truck

-  **186**
Rated payload
t
-  **1491/1900**
Rated engine power/RPM
kW/rpm
-  **111**
Body capacity (Heaped 2:1)
m³



SOLID TO SUCCEED



Add: No. 169, Heping Avenue, Xuzhou City, Jiangsu Province, China
Zip code : 221001 Hotline : 400-110-9999
Version number: DYBENE200-A25



XCMG OFFICIAL WEBSITE



XCMG SERVICE ACCOUNT

XCMG XCMG
SOLID TO SUCCEED

01

EFFICIENT
HAULING

High-Performance Engine

- Equipped with an original imported high-performance diesel engine, available in two powertrain options: Cummins and MTU. The Cummins QSK50 engine maintains full power at an altitude of 2,548 meters, while the MTU 12V4000 engine delivers full power up to 5,500 meters. Both engines comply with China Non-Road Stage III and U.S. EPA Tier 2 emission standards, ensuring reliable performance and powerful output.
- Generates clean, low-noise, and efficient power.
- Features reliable performance, advanced technology, easy fault diagnosis, and convenient maintenance.

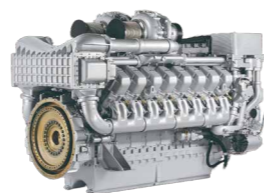
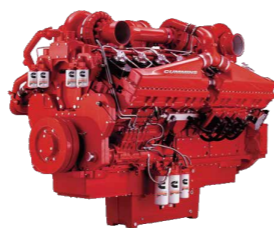

AC Electric Drive System

- The XCMG 200AC electric drive system is independently designed, developed, and integrated by XCMG. This intelligent system integrates the generator, converter cabinet, traction motor, and braking resistor, offering high power density, compact size, lightweight design, high efficiency, low energy loss, and long service life.
- Compared to mechanical drive systems, electric drive systems have a simpler structure, lower oil and fluid maintenance requirements, reduced maintenance time, and lower overall maintenance costs.
- The main generator is a three-phase brushless excitation AC generator, ensuring long service life and minimal maintenance.
- The traction motor is a three-phase squirrel-cage AC variable frequency induction motor, known for its proven technology, high reliability, and long lifespan.
- The system includes status monitoring for the converter, generator, and traction motor, along with overheat protection, further extending its service life and reducing operational costs.

Electric Retarder Control System

The XDE200 dynamic retarder system provides a maximum braking power of 2,520 kW and a continuous braking power of 1,800 kW, ensuring safe braking for fully loaded continuous downhill operations. This enhances vehicle safety and operational efficiency.

Onboard Weighing System

The onboard weighing system monitors and analyzes vehicle load data, helping to optimize payload, maximize productivity, and reduce the machine's lifecycle cost.

The system tracks and records the following key production parameters:

- Effective payload
- Total number of hauls
- Total transported weight
- Payload percentage distribution statistics
- Empty and loaded time & distance



02

HIGH
RELIABILITY & DURABILITY

Reinforced Frame Design

The XDE200 frame is designed using advanced computer-aided design (CAD), finite element analysis (FEA), and validated through full-condition dynamic testing, ensuring high load-bearing structural strength and reliability. The frame adopts a box-section design and is made from high-strength alloy steel plates, offering excellent fatigue resistance, low-temperature impact toughness, and weldability. In key high-stress areas, the frame uses 17 cast steel parts and 2 forged parts, with an expected service life of over 90,000 hours.

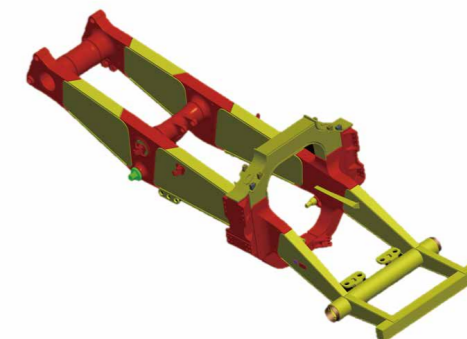

Reliable Hydraulic System

The hydraulic system is designed to be simple and reliable, controlling steering, braking, and lifting functions while minimizing the number of components. It adopts a modular design approach, with the hydraulic pump and lifting valve assembly integrated on the same bracket for easy and quick maintenance and replacement. The multi-stage hydraulic oil filter design offers high filtration precision, large dirt-holding capacity, and long maintenance intervals.

Two-Stage
NGW Planetary Gearbox

The XDE200 electric wheel gearbox uses a power-split two-stage NGW planetary gearbox. The high-speed stage sun gear receives the input, and the high-speed stage planet carrier transmits the power to the low-speed stage sun gear. The torque is finally output through the dual planetary gear set. The NGW gearbox features a compact structure, small size, high transmission ratio, large output torque, smooth operation, low noise, high efficiency, safe performance, and long service life, with a gear design life of $\geq 60,000$ hours.



UNLIMITED INNOVATION

03

ENHANCED
COMFORT & SAFETY

Ergonomically Designed Cab

The design of the cab provides a comfortable and safe working environment to meet the modern demands of mining. The cab features a ROPS and FOPS design, meeting the ISO 3471 and ISO 3449 standards. The ergonomically designed interior layout includes a rational arrangement of components, offering spacious interior space and an integrated touch display screen. The HVAC system meets the requirements of most mining area applications. The cab is equipped with double-layer laminated glass, double-seal door structure, and a pressurization system to control the airtightness and noise level from multiple angles and perspectives.

User-Friendly Display Interface

The XDE200 is equipped with a dashboard that includes a CAN bus LCD combination instrument, display screen, and functional switches, allowing the operator to easily monitor vehicle status parameters and fault information during operation. The combination instrument integrates the display of engine, hydraulic system, driving system, and weighing system status and fault information, as well as equipment information and the ability to configure functional settings and permissions.



驾驶员耳旁噪声73dB(A)

Comfortable and Durable
Suspension System

The suspension system employs four hydraulic cylinders with a variable oil-to-gas (specifically oil-to-nitrogen) ratio, which can mitigate the impacts caused by transportation roads and loading operations. This provides a smooth and comfortable riding experience for the driver while extending the lifespan of the chassis. The front suspension utilizes an independent suspension with variable stiffness, featuring left-right symmetry to ensure reliable wheel alignment and stable, comfortable driving. The rear suspension adopts a longitudinal triangular swing arm suspension, allowing the rear axle housing to swing and effectively absorbing the bending and torsional stresses generated by rough road surfaces.

Reliable and Safe
Braking Control

A proven and reliable braking system ensures safe and efficient vehicle operation, allowing the operator to focus on transport and production tasks. The XDE200 is equipped with high-performance dry disc hydraulic brakes on both the front and rear wheels, featuring service braking, loading braking, parking braking, and emergency braking functions. Combined with the electric retarder system, this enables hybrid braking control, ensuring excellent braking performance at various operating speeds. The braking system is also equipped with a brake accumulator and complies with the ISO 3450 standard.

Multi-Directional Adjustable Seat

Driver comfort is a key factor for safe and efficient production, and the XDE200 is equipped with a luxurious air-suspended seat that effectively absorbs vehicle vibrations and reduces driver fatigue. The seat is multi-directionally adjustable and works in conjunction with the telescoping/tilting steering column to meet the ergonomic needs of different drivers, enhancing comfort. The seat includes armrests, seat belts, and a headrest for added comfort and safety.

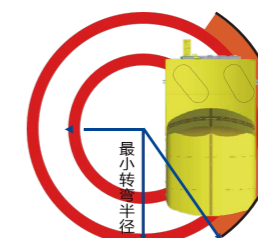

Agile Steering Performance

The XDE200 utilizes an integrated steering mechanism with a double-acting hydraulic steering cylinder for power steering, along with a steering accumulator for emergency steering control, which complies with the ISO 5010 standard. The vehicle's turning radius is 13.5 meters, providing high maneuverability and ensuring safe and efficient operation on winding roads in mining environments.

04 EASY MAINTENANCE

Convenient Maintenance Access

The XDE200 is designed with ease of maintenance in mind, allowing for fast and convenient servicing. Maintenance ladders are installed on both sides of the front longitudinal beams, providing easy access for engine inspection and maintenance. The front bumper is equipped with an engine emergency stop switch and a ladder light switch. Additionally, quick fuel refueling ports are located on both sides of the mid-frame, enabling ground-level operation for maintenance personnel.

Centralized Refilling System

Centralized refilling system consists of receiver, dust cap, flange, and dust breather, including the filling and drain facilities for engine oil, hydraulic oil, fuel, grease, and coolant. The centralized refilling device is located on the right side of the front frame longitudinal beam, positioned close to the ground for easy operation.

Modular Design for Easy Assembly and Disassembly

The XDE200 features a modular design, making it easy to disassemble, assemble, transport, and maintain. Notably, the frame and rear axle utilize mountable joint bearings, allowing for quick disassembly and assembly, reducing downtime for repairs, and enhancing vehicle availability.



FUNCTION

Auto Centralized Lubrication System

The XDE200 is equipped with a fully automatic centralized lubrication system, ensuring optimal lubrication for 19 key articulation points. This system reduces maintenance time, improves maintenance quality, and lowers workload intensity. Additionally, it features pressure detection, alarms, and programmable lubrication intervals.



LCD Display

- The cab instrument display is designed for installation, maintenance, and troubleshooting.
- Basic troubleshooting can be performed without accessing the control cabinet.





Promise to You

XCMG MINING MACHINERY'S
COMMITMENT TO YOU

CUSTOMIZED SERVICES TO ACHIEVE A FULL-CYCLE, ALL-AROUND EXCLUSIVE SERVICE FOR CLIENTS—MANAGER—DELIVERY—PROJECT OPERATION & MAINTENANCE—SERVICE—BUSINESS.

XCMG forms a management team centered around client managers, solution managers, and delivery managers, working efficiently and collaboratively with deep client interaction to provide full-cycle, comprehensive services for customers.

XDE200

Double-axle rigid mining truck

Technical Parameters

Engine

Model ①	Cummins QSK50
Emission standard	GB20891-2014 China Stage III / U.S. EPA Tier 2
Fuel	Diesel
Number of cylinders	16
Stroke	4-Stroke
Total power*	1491kW(2000HP)@1900rpm
Flywheel net power**	1385kW(1850HP)@1900rpm
Weight (wet)	6373kg
Model ②	MTU12V4000C23R
Emission standard	GB20891-2014 China Stage III / U.S. EPA Tier 2
Fuel	Diesel
Number of cylinders	12
Stroke	4-Stroke
Total power*	1510kW(2025HP)@1900rpm
Flywheel net power**	1390kW(1865HP)@1900rpm
Weight (wet)	7700kg

*The total power refers to the output power of the engine installed on this machine. The engine speed is controlled, and the fuel settings are approved by the engine manufacturer. Accessory losses include the water pump, fuel pump, and oil pump.

** The flywheel net power is the rated power of the engine flywheel minus the average accessory losses. Accessories include the fan and charging AC generator. Complies with SAE J1349 standard.

Electric drive system

AC-DC-AC electric drive	
AC generator	XCMG-A1400
Cooling fan	XCMG-F350
Electrical control cabinet	XCMG-D200AC
AC electric wheel*	XCMG-M630
Gear ratio	34.57:1
Max. speed	56km/h

Tires and rims

Tubeless, radial tires, standard tires*	37.00R57
Flange-mounted, five-piece rims	27.00/6.0
Rim rated cold inflation pressure:	
758 kPa (110 psi), typical tire (6) total weight	18180kg

* Tires should meet tkph/tmph, tread, compound, inflation pressure, ply rating, or equivalent requirements.

Cab

ROPS/FOPS cab meeting ISO 3471/ISO 3449 (Level II) rollover protection and falling object protection standards. Spacious interior with a wide field of view. Equipped with various display instruments, alarms, lighting, control switches, radio, and more. The driver's seat is an adjustable air suspension seat with a high backrest, and a co-driver's seat is also provided. It features an onboard computer, power windows, tilt and telescopic steering wheel, electric windshield wipers and washers, tinted glass, and air conditioning with heating and cooling functions. The vehicle operation data and fault alarms are displayed using an LCD screen in combination with controllable instruments.

Suspension

Variable oil/nitrogen suspension cylinders with integrated rebound control	
Maximum front suspension stroke	330mm
Maximum rear suspension stroke	276mm
Maximum rear axle lateral oscillation angle	±5°

Frame

The frame consists of a pair of longitudinal beams and five crossbeams, forming a closed structure. Both the longitudinal and crossbeams have a box-section design, eliminating stress concentrations that cause bending and cracking. The frame is made of high-quality, low-alloy, high-strength steel, with cast components used in high-stress areas to enhance strength. All critical welds undergo 100% ultrasonic testing.

Drive axle installation	Connected by pins, spherical bearings, and bushings
Lateral positioning of the drive axle	Connected by lateral stabilizer rods

Dump body

The dump body is constructed with a high-strength floor and side panels, with strength greater than 1000 MPa, ensuring a robust structure. High-hardness wear-resistant liners extend the service life of the dump body. The body floor has a single-slope design, ensuring clean dumping. The dump body is equipped with safety rope anchors. A heated body is available as an optional configuration.

Floor	20 mm (Thickness)
Front panel	12 mm (Thickness)
Side panel	10 mm (Thickness)
Canopy panel	6 mm (Thickness)
Struck	77m ³
Heaped 2:1 (SAE)	111m ³
Standard XCMG dump body weight	27000kg

Braking system

The braking system complies with ISO 3450-2011 requirements.	
Service brake: fully hydraulic drive	
Front brake	Brake disc diameter: 1060 mm, 3 Calipers/Disc
Front brake pressure	15mPa
Rear brake	Brake disc diameter: 635 mm, 2 Discs/Wheel, 1 Caliper/Disc
Rear brake pressure	10mPa
Auxiliary braking system	Automatically engages when hydraulic system pressure falls below threshold (pressure supplied by accumulator)
Loading brake	Switch-activated implementation on rear wheel service brakes
Parking brake	Spring-applied, hydraulic-released
Electric retarder	Max. power: 2520kW

Cooling system

Cushioned tube-and-belt structure radiator, integrated top-mounted expansion tank, standard pressure cap 14 PSI with manual vent valve.

Radiator front surface area	4.88 m ²
-----------------------------	---------------------

Hydraulic system

Variable plunger pump provides steering oil supply. Load-sensing flow-amplifying power steering system provides low steering wheel torque, fast steering response, high precision and smooth steering. The accumulator supplies emergency steering hydraulic pressure.

Steering	
Turning diameter (SAE)	27m

Suction filter:	250 μm
Return filter:	12 μm

Hoist and steering high-pressure filter: 12 μm

Brake component cabinet Located on the deck behind the cab for easy inspection.

Lifting Two 3-stage double-acting external cylinders with built-in cushion valve.

Lifting time

-Lifting (load)	22s
-Lowering (high idle)	13s
-Lowering (low idle)	15s

Pump Dual-pump direct drive

Series gear pump
-Lifting pump Flow rate: 772L/min@1900rpm
Max. operating pressure: 20 MPa

Variable plunger pump
-Steering pump Flow rate: 275L/min@1900rpm
Max. operating pressure: 24 MPa

System overflow pressure

-Lifting system	20mPa
-Steering system	28mPa

Quick-connect interface available for powering a disabled truck and system fault diagnostics.

Electrical system

Six 975 CCA, 12V maintenance-free batteries, series/parallel connection, mounted on the bumper with an isolation switch.

Alternator	24V/175A
Lighting equipment	24V
Starter motor	2↑/24V

Service refill capacities

Cooling system	600L
Crankcase	220L
Hydraulic system	800L
Front wheel (each)	30L
Electric wheel (each)	100L
Fuel tank	3200L

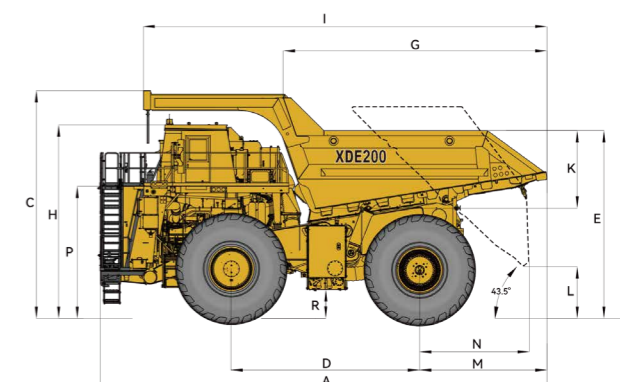

C:7050	H:6010	P:4100	I:12525
G:8180	R:900	D:5850	A:13860
N:3630	M:3945	K:2410	L:1605
E:5830	Z:13200		

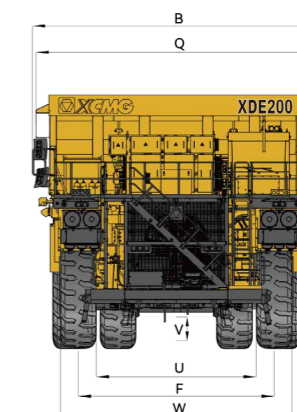

B:8350	Q:8100	V:710
U:4621	F:5640	W:6670

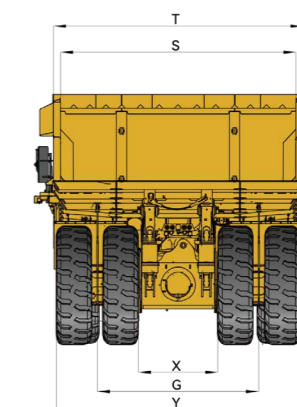

T:7300	S:6900	X:2234
G:4720	Y:7115	

**Standard dump body capacity: 77m³ (Struck); 111m³ (Heaped 2:1 (SAE))

*Tire 37.00R57

Performance curve

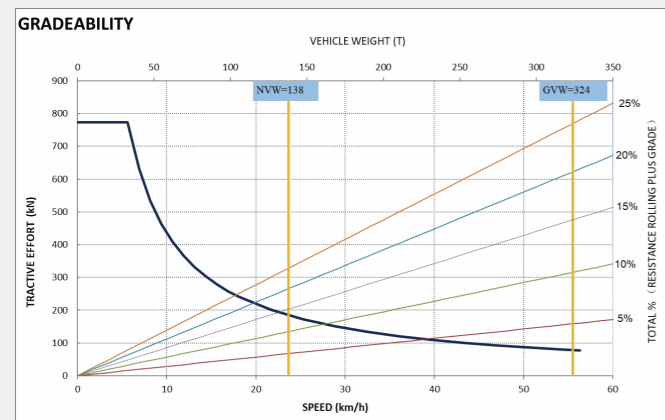

- 7% EG grade – average speed: 19.2 km/h
- 10% EG grade – average speed: 13.5 km/h
- 12% EG grade – average speed: 11.2 km/h

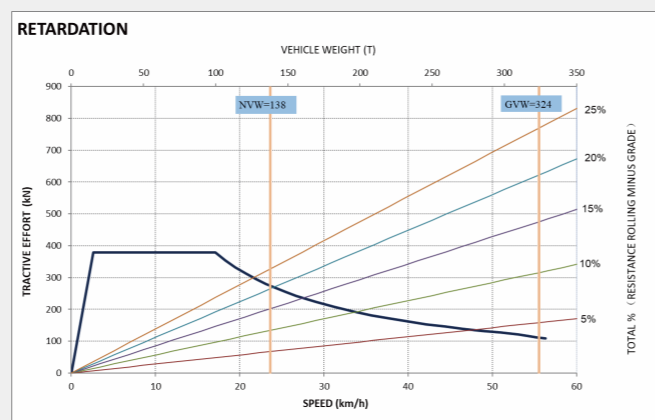

- Max. allowable speed on a 5% grade: 37km/h
- Max. allowable speed on a 7% grade: 26km/h
- Max. allowable speed on a 10% grade: 18km/h

NVW

Front axle distribution (50%)	69000 kg	152119 lbs
Rear axle distribution (50%)	69000 kg	152119 lbs
NVW	138000 kg	304238 lbs

GVW

Front axle distribution (33%)	106920 kg	235718 lbs
Rear axle distribution (67%)	217080 kg	478579 lbs
Gross vehicle weight	324000 kg	714297 lbs

Payload

Effective payload	186000 kg	410059 lbs
-------------------	-----------	------------

* Rated payload includes all optional accessories.

Equipment operation and notes

XCMG mining truck loading specifications

Loading specifications specify loading guide and limits of XCMG mining truck

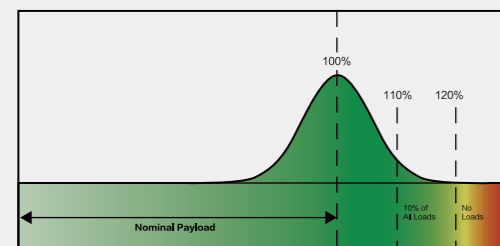

- The Gross Vehicle Weight (GVW) includes chassis, body, tires, attachments, lubricants, fuel, operator, effective payload, and any accumulated excess material.
- The average monthly payload must not exceed the rated payload of the truck.
- 90% of all loads must be below 110% of the rated payload of the truck.
- 10% of all loads must be between 110% and 120% of the rated payload of the truck.
- No single payload may exceed 120% of the rated payload of the truck.

Notes:

1. The graphics and information in this brochure reflect the technical specifications and configuration standards of certain models at the time of publication. The information and data are based on standard usage condition tests. The above data and information are for reference only. Please refer to the actual vehicle.
2. This brochure is for reference only and is not legally binding. For detailed information, please contact your local XCMG Mining Machinery dealer.
3. No part of this brochure may be reproduced without the authorization of Xuzhou XCMG Mining Machinery Co., Ltd.

Xuzhou XCMG Mining Machinery Co., Ltd. reserves the right to interpret and modify this brochure.

Standard configuration

- Self-cleaning air filter
- Alternator (24V/140A)
- Automatic lubrication system, liquid level indicator
- Back-up alarm
- Battery-6 pieces 975CCA
- Battery charging/jump-start connector
- Cargo compartment position limiting device
- Cargo compartment safety rope
- Front brake: Dry disc brake
- Rear brake: Dry disc brake
- Electric control cabinet
- Electric retarder cruise system
- Electric start
- Quick filling fuel system (on fuel tank and at hydraulic oil tank side)
- Hydraulic high-pressure filter
- Mirror:
 - Left side: flat mirror with heating function
 - Right side: convex mirror with heating function
- Mudguard
- Muffler - mounted on the deck
- Power supply, 24V, 12V dc
- Quick coupling (for lifting and diagnosis)
- Radiator liquid level indicator
- Detachable power assembly (engine, alternator)
- Electric retarder
- Fan clutch

Operating environment and control

- Full hydraulic service brake, automatically applied type
- Power switch
- Brake and traction interlock
- 24V circuit breaker
- Boarding ladder
- Dynamic deceleration
- Engine emergency stop button - ground
- Lifting and towing interlocking device
- Horn (electric - front)
- Integral ROPS/FOPS (standard) driver's cab
- Parking brake with warning lamp and speed application protection
- Power steering system with automatic auxiliary steering
- Deck handrail
- Transmission shaft shield
- Radiator fan cover
- Seat belt: standard three-point type
- Anti-skid passage
- Engine access platform, left/right

Lighting device

- Backup light - LED is rear mounted (2)
- Backup light - left and right - LED is deck mounted (2)
- Brake and deceleration lamp LED mounted on top of driver's cab
- Turn/marker lamp LED (8)
- Dynamic deceleration lamp, rear (2) LED
- Engine compartment inspection lamp (4) LED
- Axle inspection lamp (LED)
- Fog lamp (2) LED
- Head lamp (8) LED
- Ladder lamp and platform lamp LED
- Brake lamp, rear (2) LED

Standard luxurious driver's cab

- Ac drive interface display screen
- Air conditioner R-134A
- AMFM radio, equipped with USB and MP3
- Turbocharger plugged alarm
- Roof light
- Multi-purpose driver's display panel
 - Light status
 - Engine hour, oil pressure, coolant temperature, oil temperature and fuel level

Standard luxurious driver's cab

- Multi-purpose driver's display panel
 - Mileage, speed and duty load
 - Ambient temperature and time
 - System voltage
 - Engine red light alarm and yellow light alarm
 - Low system voltage
 - Low engine coolant level
 - Gear position indicator
 - Excitation indicator
 - Parking brake indicator, service braking indicator, electric braking indicator, loading brake indicator
- Delayed engine shutdown
- Floor mat (two-floor baffle)
- Fuel gauge of the driver's cab
- Low fuel level indicator lamp and buzzer
- Instrument (with backlight)
- Front headlamp switch
- Heater and defroster (heavy duty)
- Radiator switch
- High beam light selector and indicator
- Horn (steering wheel center)
- Weighing system display
- Driver's seat, adjustable, with air suspension, waist support and armrest panel lighting (adjustable)
- Co-driver's seat
- Power window
- Positive pressure driver's cab
- Electric retarder brake pedal
- Hydraulic brake pedal
- Sun visor (adjustable)
- Telescoping/tilting adjustable steering column
- Voltmeter (voltage output)
- Windshield glass (colored safety glass)
- windshield wiper (double) and washer (electric drive)

Optional devices

- Note: Optional devices may change working weight.
- 1000L/min Quick filling fuel system (on fuel tank and at hydraulic oil tank side)
 - Amber signal lamp
 - Power switch lockset
 - Antifreeze solution: below -40C
 - Cargo compartment I standard design
 - Cargo compartment heating
 - Cargo compartment component, OEM bulk shipment
 - Anti-wear plate of cargo compartment
 - Stone deflector/stone chain
 - Hydraulic ladder
 - Hydraulic oil tank ladder
 - Fuel tank ladder
 - Low-temperature suspension system I - front and rear
 - Electric heater (engine coolant, engine oil, hydraulic oil and fuel)
 - Liquid fuel heater (engine coolant)
 - Fire extinguisher
 - Full-automatic centralized fire extinguishing
 - Centralized filling - right (coolant, engine oil, hydraulic oil and grease)
 - Mudguard I - fuel tank and hydraulic oil tank
 - Seven-piece type quick-mounting wheel rim
 - XCMG- 360° panoramic image system
 - Weighing display I - right side and left side
 - Suspension inflation kit
 - Tool box
 - Tires
 - Driver's behavior monitoring system
 - Anti-collision warning system
 - Blind zone monitoring system
 - Tire temperature monitoring system
 - Tire pressure monitoring system
 - They are compulsory to a cargo compartment provided by XCMG; cargo compartments designed by XCMG and manufactured locally are recommended. Not applicable to a third party.