



XDE260

HAUL TRUCK

220t
Rated Load

1864kW
Engine Rated Power

148m³
Body SAE Heaped 2:1



XUZHOU CONSTRUCTION MACHINERY GROUP IMP. & EXP. CO., LTD

Address: No.1, Tuolanshan Road,
Xuzhou Economic Developing Zone, jiangsu, China 221004
Tel: + 86(0)516 8773 9572
E-Mail: xcmglobal@xcmg.com



@XCMGGROUP | Q



WeChat



Website

Under our policy of continuous product development and improvement, we reserve the right to change specifications and design without prior notice. Featured machines in photos may include additional equipment. Consult your XCMG dealer for available options and attachments.

For more complete information on XCMG products, dealer services and industry solutions, visit us on the web at www.xcmglobal.com

XCMG, Solid To Succeed and www.xcmglobal.com, as well as corporate and product identity used herein are trademarks of XCMG and may not be used without permission.

Ref.No.XCMG2605 English

DYBENE260-A26

01

HIGH PRODUCTIVITY

High-Performance Engine

- It features original imported high-performance diesel engines with options of MTU or Cummins power assemblies. The MTU16V4000 engine sustains full power up to 5500 meters altitude, while the Cummins engine QSK60 maintains power at altitudes up to 1829 meters. It adheres to China's national off-road stage III and U.S. EPA Tier 2 emission standards, with reliable and powerful performance.
- It produces clean, quiet, and efficient power.
- Engine performance is reliable with advanced technology, convenient for diagnostic troubleshooting, and easy to maintain.



Wabtec Electric Drive System

- It utilizes the imported Wabtec electric drive system for safe and reliable operation, with a low failure rate and low maintenance costs. This ensures constant power control and stepless speed adjustment, as well as strong traction capability, to maintain maximum production efficiency.
 - Compared to mechanical drive systems, the electric drive system has a simpler structure, uses less fluid for maintenance, requires less time for repair, and has lower maintenance costs.
 - The main generator employs a three-phase AC synchronous generator with a long service life and convenient maintenance.
 - The traction motors use three-phase squirrel cage AC variable frequency induction motors, with mature technology, reliable and durable, and a long lifespan.
- * Optional XCMG 260 electric drive system available**

Electric Retarder Control System

The XDE260 electric retarder system provides a maximum braking power of 3900HP (2910kW), with continuous braking power at 3700HP (2761kW), meeting the braking requirements of fully loaded continuous downhill travel, thus enhancing operation safety and production efficiency.

Weighing System

- The on-board weighing system is designed for payload data detection and analysis, aiming to optimize the payload and maximize productivity, while reducing the machine's life cycle costs. The on-board weighing system tracks and records the following key manufacturing parameters:
- Payload
 - Total number of hauls
 - Total weight transported
 - Percentage distribution of payload
 - Times and distances of unload and full load



02

HIGH RELIABILITY



Long-Life Frame Design

The XDE260 frame employs advanced computer-aided design and finite element analysis methods, validated through comprehensive dynamic testing under all operating conditions. This ensures the frame's high structural strength and reliability for heavy-duty applications. Featuring a box-section design and manufactured from high-strength, premium alloy steel plates, the frame delivers excellent fatigue resistance, low-temperature impact toughness, and weldability. To further enhance reliability, cast and forged components are utilized in critical high-stress areas.

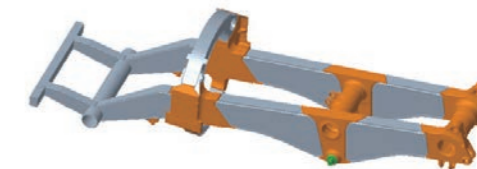

Simple and Reliable Hydraulic System

The hydraulic system is elegantly simple and dependable, utilizing fewer components to control steering, braking, and lifting functions. A modular design approach allows the hydraulic pump and lift valve components to be mounted on the same support for quick repairs and replacements. Multiple stages of hydraulic oil filters ensure high filtration precision, large contamination capacity, and extended maintenance intervals.



Robust and Reliable Body Design

Manufactured from high-strength, low-alloy wear-resistant steel plates, the XDE260's body features optimized structures at the hoist cylinder tipping seat and frame hinge support areas for enhancing localized strength and improving fatigue resistance. Utilizing CAE software, the complete structure of the body undergoes simulation analysis for optimization, ensuring its strength and rigidity, and enhancing reliability and durability.

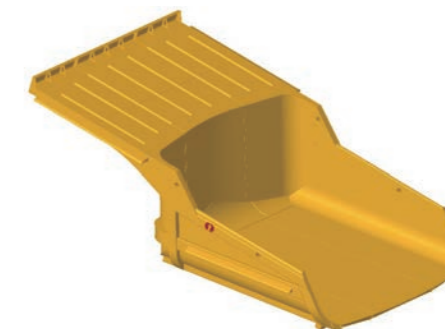

UNLIMITED INNOVATION

03

COMFORTABLE AND SAFE

Ergonomically Designed Cab

The cab design provides a comfortable and secure operating environment to meet modern mining requirements. It is constructed with ROPS and FOPS structures that conform to ISO 3471 and 3449 standards. The ergonomically interior decoration, component layout, extra large interior space, and integrated touch display screen, all focus on ergonomics. The cab features a climate control system catering to most mining areas. Double layered laminated windows, dual-sealed doors, pressure system for cab, and multi-directional and multi-angle control for air-tightness and noise reduction.

User-Friendly Display Screen

The XDE260 features a practical and easily readable dashboard, equipped with a CAN-bus LCD instrument cluster, display screen, and functional switches for the driver to monitor truck's status parameters and fault information in the process of driving. The instrument cluster consolidates the engine, hydraulic system, drive system, and weighing system status information, including fault display and equipment information settings.



Comfortable and Durable Suspension System

The suspension system uses four gas-oil ratio variable nitrogen/oil cylinders to reduce the impact from the transportation road and load, so that the frame service life could be extended. The front suspension has a variable stiffness independent design, and the left and right are symmetrical, ensure wheel alignment and stable, realizing excellent riding comfort. The rear suspension is the longitudinal triangular independent suspension of the swing arm type, which allows the swing of the rear axle housing, and effectively absorb the bending and torsional stresses caused by the harsh road.



Multi-Directional Adjustable Seat

The driver's operating comfort is the key to safe and efficient production, and the XDE260 is equipped with luxurious air-suspended seats that absorb vibrations and reduce fatigue. The seat is adjustable in multiple directions. It is used in conjunction with a retractable/tiltable steering column to accommodate different driving postures for improving comfort. Seat armrests, safety belts, and cushions are included as accessories.

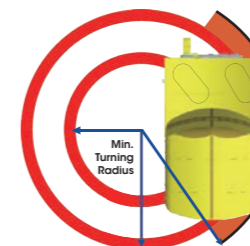

Reliable and Safe Braking Control

Mature and reliable braking system ensures safe and efficient operation of truck, boosting driver confidence and enabling them to focus on production and transportation tasks. The XDE260 is equipped with superior-performance hydraulic disk brakes on both the front and rear wheels, providing functions for service braking, loading braking, parking braking, and auxiliary braking. Combined with the electric braking function of the electric drivetrain to realize hybrid braking control of the truck, the truck has excellent braking performance at all operating speeds. The braking system includes an accumulator and its parameters are superior to the ISO3450 indicator.

Agile and Flexible Steering Performance

The XDE260 utilizes an integrated steering mechanism powered by dual-action hydraulic steering cylinders, with an accumulator for emergency steering control that complies with ISO 5010. A turning radius of 14.2 meters, high mobility ensures the high safety of the vehicle in the mine harsh road.

04 EASY MAINTENANCE

Convenient Maintenance Access

The design of the XDE260 takes maintainability into account, allowing for quick and easy servicing. Maintenance ladders are provided on both sides of the front longitudinal beams to offer convenient access for engine inspection and maintenance. The front of the vehicle bumper is equipped with an engine emergency stop switch, a ladder light switch, and fuel quick-fill ports on both sides of the center of the frame, making it easy for maintenance personnel to operate on the ground.

Concentrated Oil-Filling System

The centralized filling system consists of receivers, dust caps, flanges, and dust respirator, including filling and discharging oil, hydraulic fluid, fuel, grease, and coolant. The centralized filling device is located on the right side of the front frame's longitudinal beam, close to the ground, making it easy to operate.

Modular design For Easy Assembly and Disassembly

XDE260 whole truck adopts modular design, which is easy to disassemble, install, transport and maintain. In particular, the frame and rear axle adopt an imounted joint bearing seat, which simplifies assembly and disassembly, reduces downtime for maintenance, and enhances truck's availability.



Full-Automatic Centralized Lubrication System

XDE260 is equipped with full-automatic centralized lubrication system, which fully lubricates 19 articulation points of the key moving parts of the vehicle, saves vehicle maintenance time, improves the quality of vehicle maintenance work, and reduces the intensity of vehicle maintenance work. The automatic lubrication system has pressure detection, alarm and lubrication interval programmable control.



LCD Screen

- The cab's instrument display is used for installation, maintenance, and troubleshooting.
- The main page of the display shows important driving information such as vehicle speed, engine speed, engine water temperature, etc., which makes it easy for the driver to check the status of the whole vehicle.
- Basic troubleshooting no longer requires access to the control cabinet.





Promise To You

XCMG MINING MACHINERY'S COMMITMENT TO YOU

CUSTOMIZED SERVICES TO ACHIEVE A FULL-CYCLE, ALL-AROUND EXCLUSIVE SERVICE FOR CLIENTS—MANAGER—DELIVERY—PROJECT OPERATION & MAINTENANCE—SERVICE—BUSINESS.

XCMG forms a management team centered around client managers, solution managers, and delivery managers, working efficiently and collaboratively with deep client interaction to provide full-cycle, comprehensive services for customers.

XDE260

DOUBLE-AXLE RIGID MINING TRUCK

TECHNICAL PARAMETERS

Engine

Model ①	Cummins QSK60
Emission standard	GB20891-2014国三/U.S. EPA Tier2
Fuel	Diesel fuel
Number of cylinders	16
Stroke	4-stroke
Gross power*	1864kW(2500HP)@1900rpm
Net flywheel power**	1754kW(2350HP)@1900rpm
Weight (dry)	8470kg
Model ②	MTU16V4000C23R
Emission standard	GB20891-2014国三/U.S. EPA Tier2
Fuel	Diesel fuel
Number of cylinders	16
Stroke	4-stroke
Gross power*	1865kW(2500HP)@1800rpm
Net flywheel power**	1754kW(2350HP)@1800rpm
Weight (dry)	8300kg

*Gross Power is the output of the engine as installed in this machine, at governed rpm and with engine manufacturer's approved fuel setting. Accessory losses included are water pump, fuel pump and oil pump.

**Net Flywheel net power is the rated power at the engine flywheel minus the average accessory losses. Accessories include the fan and the alternator, which comply with SAE J1349 standard.

Electric Drive System

AC electric drive system	Wabtec Drive System
Drive mode	AC-DC-AC
Alternator	5GTA41
AC electric wheel	5GEB25
Wheel gear reduction ratio	31.875:1
Speed (max.)	64km/h
*Optional	XCMG 260AC Drive System

Tires and Rims

Tubeless, radial tires, standard tires*	50/80R57
Flange mounted, five-piece rims	32.00/6.0
Rim rated cold inflation pressure: 758 kPa (110 psi) Typical tire (6) total weight	23184kg
*Tires should meet application requirements for their TKPH/T-MPH tread, compound, inflation pressure, plyrating, or equivalent etc.	

Cab

The ROPS/FOPS cab, which aligns with ISO 3471/ISO 3449 (Level II) standards for anti-rollover/anti-falling object protection, offers a spacious space and a wide vision, with all kinds of display instruments, alarms, lighting devices, control switches, radio and relevant devices completely provided, including an adjustable air-suspending damping high-backrest driver seat, a front passenger's seat, a vehicle computer, electric windows, a tilting and telescoping steering wheel, electric windshield wipers, colored glass and an air-conditioning system with both heating and cooling options. The vehicle running data and fault alarm contents are displayed by means of a touch LCD display plus controllable instruments.

Suspension

Variable oil/nitrogen suspension cylinder with integrated rebound control	
Max. stroke of front suspension	330mm
Max. stroke of rear suspension	292mm
Max. lateral swing angle of rear axle	±10.3°

Frame

The frame is made up of a pair of longitudinal beams and five cross beams, which together form an enclosed structure. Both the longitudinal and cross beams adopt a box-section structure to help eliminate concentrations of bending and cracking stress. The frame is constructed of high-quality, low-alloy, and high-strength steel, with castings used in high-stress areas to increase the frame strength. All critical welds are 100% inspected using ultrasonic testing.

Installation of drive axle	Connected by pin shaft, knuckle bearing and bushing
Lateral positioning of drive axle	Connected by a lateral stability tie rod

Dump Body

High-strength body bottom plates and side plates are used, providing a robust structure and long service life. The bottom plate features a single-slope design for clean unloading and is equipped with safety rope supports, body cushioning pads, and stone discharge devices.

Bottom plate	Thickness 18mm
Front plate	Thickness 12mm
Side plate	Thickness 10mm
Cap plate	Thickness Front 5mm, Rear 8mm
Flat loading	108m ³
SAE 2:1	148m ³
Standard body weight	29920kg

*Customizable according to customer requirements

Braking System

The braking system complies with the ISO3450-2011 standard	
Front brake	Brake disc diameter: 1160mm, 4 calipers/disc
Front brake pressure	19MPa
Rear brake	Brake disc diameter: 635 mm, 2 disks/wheel, 1 caliper/disc
Rear brake pressure	13MPa
Auxiliary braking system	When hydraulic system pressure is below a set value, the system is automatically engaged (pressure supplied by accumulator)
Loading brake	Switch activated, with service brakes applied to rear wheels
Parking brake	Spring applied, hydraulic released
Electric retarder	Max. 2910 kW

Cooling System

Buffer tube structure radiator, integrated overhead expansion tank.	
Radiator frontal area:	6.47m ²

Hydraulic System

Variable plunger pump provides steering fluid, with load-sensing, flow amplifying power steering system; steering wheel requires low effort to manipulate, with quick response, high precision, and smooth operation. The accumulator provides emergency steering fluid source.

Steering	Oil suction filter 250μm
Turning diameter (SAE)	28.4m
Filter	Oil return filter 10μm
	Lifting and steering high-pressure filter 10μm

Brake components cabinet Located on the deck behind the cab for easy diagnostics

Lifting Two 3-stage, double-acting external cylinders with built-in cushion valves

Lifting time	
- Lifting (load)	28s
- Lowering (high idle speed)	18s
- Lowering (low idle speed)	25s

Pump Double-pump direct drive
Gear pump in series connection
- Lifting pump Flow 819L/min@1900rpm
Max. working pressure: 18MPa

Variable plunger pump
- Steering pump Flow 275L/min@1900rpm
Max. working pressure: 24.5MPa

System relief pressure	
- Lifting system	18MPa
- Steering system	27.5MPa

Quick interface helps offer power to the faulty truck and for system diagnosis

Electrical System

6 maintenance-free 975CCA, 12V batteries arranged in series/parallel, mounted on the bumper with a disconnect switch

Alternator	24V/250A
Lighting equipment	24V
Starter motor	2Units/24V

Oil Filling Capacity

Cooling system	CUM 750L/MTU 800L
Crankcase*	CUM 260L/MTU 280L
Hydraulic system	960L
Front wheel (each)	40L
Motorized wheel (each)	38L
Fuel tank	4500L

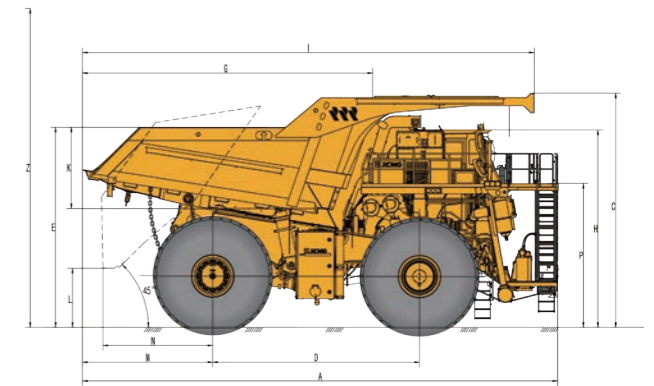

C:7205	H:6074	P:4310	I:13874
G:8838	R:870	D:6350	A:14595
N:3360	M:4000	K:2527	L:1839
E:6158	Z:14454		

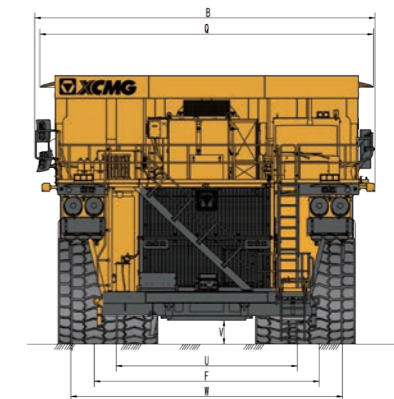

B:9104	Q:8923	V:640
U:4764	F:6020	W:7194

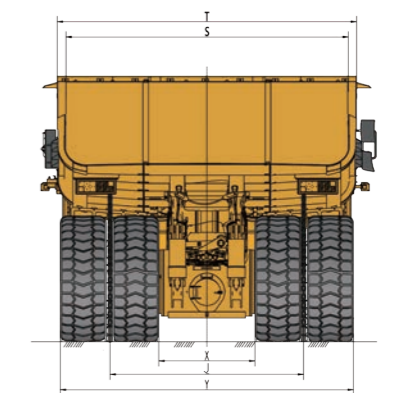

T:8130	S:7650	X:2611
J:5244	Y:7961	

*Standard body, flat loading: 108m³
SAE Heaped 2:1 148m³
*Tire 50/80R57

Performance Curve

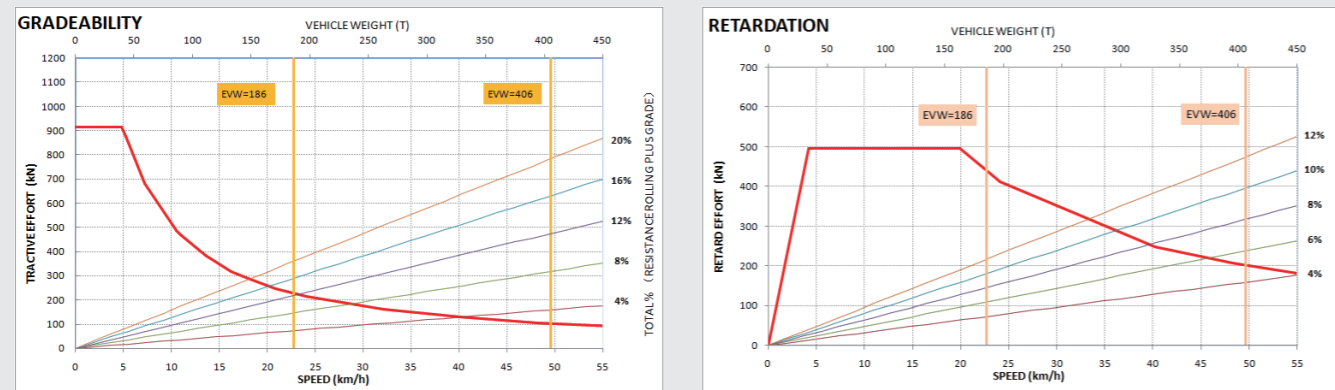

Empty Vehicle Weight (EVW)

Front axle distribution (51%)	94863 kg	209137 lbs
Rear axle distribution (49%)	91139 kg	200927 lbs
Total EVW	186002 kg	410067 lbs

Load Capacity

Payload	220000 kg	485017 lbs
---------	-----------	------------

* The rated effective payload includes all optional accessories.

Gross Vehicle Weight (GVW)

Front axle distribution (33%)	133984 kg	295384 lbs
Rear axle distribution (67%)	272023 kg	599708 lbs
Nominal GVW	406007 kg	895092 lbs

USE OF EQUIPMENT AND PRECAUTIONS

XCMG Mining Truck Loading Specifications

The loading specifications define the loading guidelines and restrictions for XCMG mining trucks:

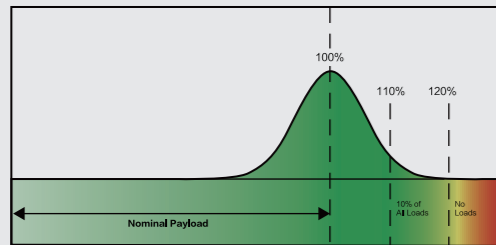

- The Gross Vehicle Weight (GVW) includes the chassis, body, tires, accessories, lubricating oil, fuel, operator, payload, and any additional material accumulation.
- The Empty Vehicle Weight (EVW) includes the standard chassis, standard body, tires, accessories, lubricating oil, fuel, and operator.
- Nominal payload=GVW-EVW
- The average of all payloads during a 30-day operation period must not exceed the rated payload.
- The actual payload must be less than or equal to 110% of the rated payload, and the proportion must be no less than 90%.
- 110% rated payload ≤ actual payload ≤ 120% rated payload, with the proportion not exceeding 10%.
- Any single load must not exceed 120% of the target payload of the truck.

Notes:

1. The graphics and information in this brochure reflect the technical features and configuration standards of certain models at the time. The existing information and data are based on standard usage testing. The above data and information are for reference only; please refer to the actual product.
2. This brochure is for reference only and does not constitute a contract. For detailed information, please contact your local XCMG Mining Machinery distributor.
3. The contents of this brochure may not be reproduced without authorization from Xuzhou XCMG Mining Machinery Co., Ltd. Xuzhou XCMG Mining Machinery Co., Ltd. reserves the right to interpret and modify this brochure.

Standard Configuration

Self-cleaning air filter
 Alternator (24V/250A)
 Automatic lubrication system, liquid level indicator
 Backup alarm
 Battery – 6 pcs., 975CCA
 Battery charging/jump-start connector
 Body position limiting device
 Body safety rope
 Front brake: dry disk brake
 Rear brake: dry disk brake
 Electric control cabinet
 Electric retarder cruise system
 Electric start
 Hydraulic high-pressure filter
 Mirror:
 -Left: flat mirror, with heating
 -Right: convex mirror, with heating
 Mudguard
 Muffler - mounted on the deck
 Power supply, 24V and 12V DC
 Quick coupling (for lifting and diagnosis)
 Radiator liquid level indicator
 Detachable power assembly (engine, alternator)
 Electric retarder
 Fan clutch

Operating Environment and Control

Full hydraulic service brake, with automatic engage function
 Power switch
 Brake and traction interlock
 24V circuit breaker
 Boarding ladder
 Dynamic deceleration
 Lift and towing interlock system
 Horn (electric-front)
 Integral ROPS/FOPS (Benchmark II) driver's cab
 Parking brake with warning lamp and speed application protection
 Power steering system with automatic auxiliary steering
 Deck handrail
 Transmission shaft shield
 Radiator fan cover
 Seat belt: standard three-point type Anti-skid passage
 Engine access platform, left/right

Lighting Equipment

Backup light - 2 LED units mounted at the rear
 Backup light - 2 LED units mounted on the left and right sides of the deck
 Brake and deceleration lamp LED mounted on top of cab
 Turn/marker lamp (8)(LED)
 Dynamic deceleration lamp, rear (2)(LED)
 Engine compartment inspection lamp (4)(LED)
 Axle inspection lamp (LED)
 Fog lamp (2)(LED)
 Headlamp (8)(LED)
 Ladder lamp and platform lamp (LED)
 Brake lamp, rear (2)(LED)

Standard Luxury Cab

Ac drive interface display screen
 Air conditioner R-134A
 AMFM radio, equipped with USB and MP3
 Pressurizer
 Roof light
 Multi-purpose driver's display panel
 -Light status
 -Engine hours, oil pressure, water temperature, engine oil temperature, fuel level

Standard Luxury Cab

Multi-purpose driver's display panel
 - Mileage, speed and duty load
 - Ambient temperature and time
 - System voltage
 - Engine red light and yellow light alarm
 - Low system voltage
 - Low engine coolant level
 - Gear position indicator
 - Excitation indicator
 - Parking brake indicator, service braking indicator, electric braking
 Floor mat (double baffle)
 Fuel gauge of the cab
 Low fuel level indicator lamp and buzzer
 Instrument (with backlight)
 Headlamp switch
 Heater and defroster (heavy duty)
 Radiator switch
 High beam light selector and indicator
 Horn (steering wheel center)
 Weighing system display
 Driver's seat, adjustable, with air suspension, waist support and armrest
 panel lighting (adjustable)
 Co-driver's seat
 Power window
 Positive pressure cab
 Electric retarder brake pedal
 Hydraulic brake pedal
 Sun visor (adjustable)
 Telescoping/tilting adjustable steering column
 Voltmeter (battery output)
 Windshield glass (tinted safety glass)
 Windshield wiper (double) and washer (electric)

Optional Equipment

Note: Optional devices may change working weight.

Amber Beacon Lights
 Premium Lights
 Bumper Mounted Headlights
 Heated body
 Body liners
 Rock Ejectors
 800 L/min zero-pressure fast fuel filling system
 Service center - RH
 Cryogenic suspension system: front and rear
 Hot start fuel oil (220V 500W)
 Hot start engine coolant (220V 9000W)
 Hot start engine coolant (Fuel Oil)
 Hot start hydraulic oil (220V 2*2000W)
 7 piece fast change rim*2
 Tire temperature and pressure monitoring system
 XCMG-360° panoramic video system
 Weighing Display - right and left side
 Advanced Ground CircuitChecking System(AGCCS)
 High Power Braking Resistors
 Oversized Beacon Light
 Payload Management System
 Automatic shut-off anti-overflow grease filling system
 Cab air pressure / CO₂ monitoring system
 Premium Operator Seat
 Non-slip nose plates
 Wheel chocks
 Automatic fire suppression system

Attention:

1. The use of bodies supplied by XCMG is mandatory. Bodies designed by XCMG and manufactured locally are recommended. It is not recommended to use bodies provided by third party organizations.
2. Tire temperature and pressure function is used in conjunction with tires.