



XDR100S SPRINKLER TRUCK



徐工徐工 助您成功
SOLID TO SUCCEED



单位地址：江苏省徐州市经济技术开发区驮蓝山路26号
邮编：221001 客服电话：400-110-9999
Add: No. 26, Tuolanshan Road, Economic and Technological Development Zone,
Xuzhou City, Jiangsu Province
Zip code: 221001 Hotline: 400-110-9999
版本号：DYBENR100S-A25



徐工官网
XCMG OFFICIAL WEBSITE



徐工服务号
XCMG SERVICE ACCOUNT

徐工徐工 助您成功
SOLID TO SUCCEED

XDR100S SPRINKLER TRUCK TECHNICAL SPECIFICATION

Model		Unit	XDR100S	
Overall Dimensions	Overall length	mm	10400	
	Overall width	mm	7200	
	Overall height	mm	6000	
	wheelbase	mm	4580	
	Centerline front tire width	mm	3780	
	Centerline rear dual tire width	mm	3420	
Weight Parameters	Gross machine weight	kg	160500	
	Nominal payload	kg	86000	
	Empty machine weight	kg	74500	
Weight Distributions	Empty	Front axle	kg	36505(49%)
		Rear axle	kg	37995(51%)
	Loaded	Front axle	kg	52965(33%)
		Rear axle	kg	107535(67%)
Power Parameters	Engine model	/	Cummins QST30	
	Rated engine power	kW/r/min	783/2100	
	Max. engine torque	Nm/r/min	4629/1300	
	Drivetrain	/	4 × 2	
	Tires	/	27.00R49	
Travel Parameters	Max. travel speed	km/h	48	
	Min. turning diameter	m	24	
	Max. gradeability	%	30	
	Min. ground clearance	mm	780	
Working Parameters	Filling height	mm	5900	
	Spraying width	m	15-30	
	Spraying distance	km	10-15	
	Max. range of water cannon	m	60	
Service Refill Capacities	Fuel tank	L	1050	
	Hydraulic oil tank	L	730	
	Cooling system	L	350	
	Engine oil	L	134	
	Gear oil	L	PTO: 4 Front axle (single side) :17 Rear axle (single side) :50 Rear axle (Final drive) :70	
	Transmission oil	L	100	
Water Tank Capacities	Rated capacity	m ³	90	
	Actual effective capacity	m ³	86	
Optional Equipment	Tire temperature and pressure monitoring system	/	○	
	Water tank heating	/	○	

OVERALL DIMENSIONS / WORKING RANGES

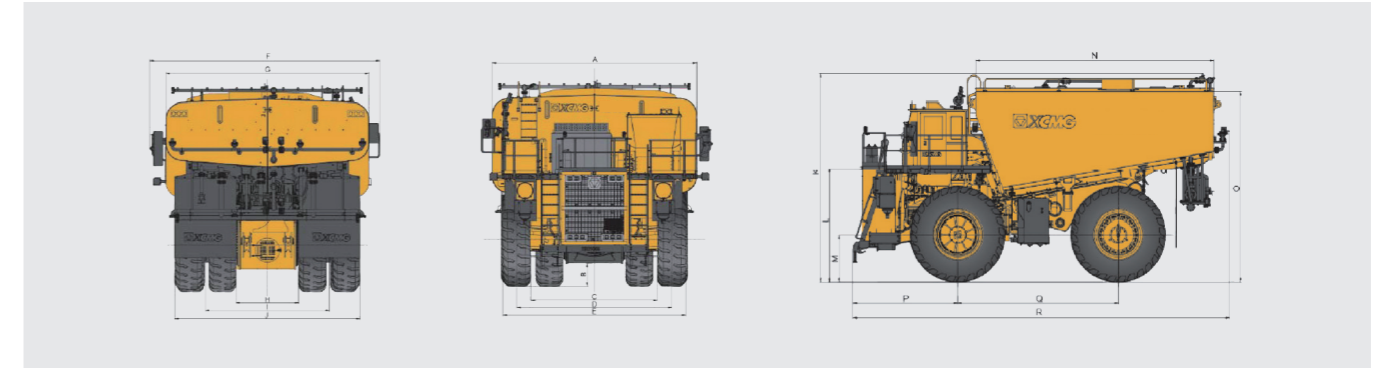

Reliable Efficiency, High Cost Performance

With a 90m³ watertank, a sprinkling width of 15–30 meters, and a sprinkling range of 10–15km, the truck also features a water cannon with a 60-meter reach. It can achieve full road coverage in a single operation, reducing the number of vehicles needed.

Flexible Operations With Multiple Options

Equipped with high-quality hydraulic components, water pumps, and an advanced spraying control system, the truck supports various operation modes such as full sprinkling, high-level sprinkling, low-level spraying, gravity flow, misting, high-pressure water cannon spraying, and road flushing.

