



XE950DA MINING EXCAVATOR

- 5.4-7.0**
Bucket Capacity
m³
- 95000**
Operating Weight
kg
- 570.5**
Rated Power
kW/rpm



SOLID TO SUCCEED

Add: No. 26, Tuolanshan Road, Economic and Technological Development Zone,
Xuzhou City, Jiangsu Province
Zip code: 221001 Hotline: 400-110-9999
Version: EYBEN950DA Plus-A25



XCMG OFFICIAL WEBSITE



XCMG SERVICE ACCOUNT

SOLID TO SUCCEED

PRODUCT INTRODUCTION

XE950DA

Based on the classic XE950DA, a more powerful engine has been installed, and the working equipment has been reinforced and the hydraulic system has been rematched and optimized.

With 23 major categories and over 400 models of mining equipment, XCMG Group has been committed to forming diversified technical routes such as pure electric, hybrid and hydrogen energy, covering full construction processes including drilling, excavation, loading, transportation, crushing, leveling, pushing and sprinkling, with series of drilling rigs, mining excavators, loaders, haul trucks, crushing and screening equipment, bulldozers, graders, water trucks and other auxiliary equipment. With this diversity and high quality, our products and quality meet the construction demands of various operations such as coal, metal, building materials, water conservancy and ports.



Reinforced working device

The arm and boom are reinforced at key points. Service life increased by 20%



Low fuel consumption

Fuel consumption reduced by 7%
Equipment adapted to various ambient temperature ranging from 50°C to -30°C



Strong power

Perkins 2806C Twin-Turbo Engine for Mining Applications Powerful performance No aftertreatment system required No urea (DEF) addition needed

01 Engine

Low fuel consumption
and low emissions



① Engine

Equipped with a Perkins 2806C twin-turbo engine designed specifically for mining applications, the excavator's engine offers fast response, powerful performance, and high reliability, with a 7% reduction in base fuel consumption compared to the previous generation.

Advanced mining engine manufacturing capabilities and timetested engine design technology ensure reliable and longer service life.

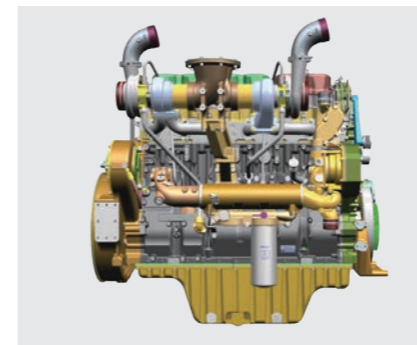

② Cooling system

The excavator applies a customized radiator with all cooling cores designed in parallel. Fully independent dual cooling systems ensure efficient cooling capacity and lower cooling power consumption.



③ Efficient-flow main valve

The excavator adopts a reputable electro-hydraulic main valve, which improves work efficiency with its excellent performance and high reliability.



④ Bucket capacity

Standard 7.0 m³ reinforced bucket with double arc design for optimized bucket shape, reducing digging resistance by 9% and ensuring smoother operation.



⑤ Boom And Arm

By increasing the thickness of key parts and optimizing the structural design, the service life has been further increased by 20% and verified through rigorous impact testing.

02

Coordinated control Practical And Durable

Hydraulic system

- ① The optimized pump valve and engine combine perfectly, bringing higher operational efficiency and lower fuel consumption.

Optimized pipeline layout

- ② Equipped with the optimized adjustment of the hydraulic system pipeline and longer hose lifespan.

Slewing Platform

- ③ Adopts 95 ton-class turntable, with higher strength and significantly improved load capacity; Fully utilizes robotic automated welding, ensuring good weld seam fusion and more stable welding quality.

Working Device

- ④ The boom and arm undergo anti-fatigue simulation design for structural optimization, resulting in significantly enhanced strength.



03

Safe And Reliable

① Safety driver's cab

The driver's cab uses stamping forming technology, providing strong resistance to impact, bending and torsion with FOPS certification, enhancing safety by 35% compared to standard driver's cabs.



② Security auxiliary devices

Equipped with rearview cameras, alarm lights, top protective nets, emergency stop switches, maintenance lighting, etc., construction safety is ensured.

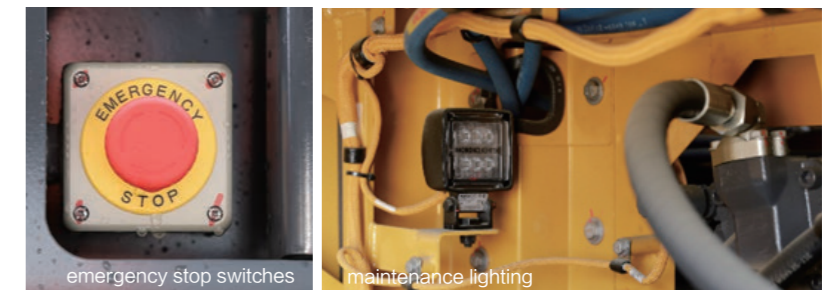

emergency stop switches

maintenance lighting

③ Anti-slip passage

The left, right and middle walkways of the superstructure adopt anti-slip design, preventing accumulation of rain and snow, facilitating mud cleaning and ensuring safer walking.



04 Comfortable Operation

① Seats

The seats are meticulously designed according to ergonomics, with the cushions and backrests providing perfect support, combined with the air suspension function, making long driving sessions less tiring. The seats feature a heating function to keep the cushions warm in cold weather, combined with automatic air conditioning to ensure comfort throughout the year.



② Touch-sensitive instrument panel

By adopting touch-sensitive instrument panel, the screen is larger and the operation is more convenient. Coupled with the buttons and knobs on the armrest box, the operation becomes more flexible.



Convenient Maintenance 05

① Maintenance lighting

Lighting is installed in the power cabin and main pump cabin, making it easier to inspect equipment at night.



② Convenient maintenance

Hydraulics and engine filter elements are centralized on both sides of the middle channel of the superstructure, within easy reach, making maintenance more convenient.



③ Automatic lubrication system

According to user requirements, an automatic lubrication system can be optionally installed, allowing the main pins of the working device to be automatically lubricated, reducing downtime for manual grease refilling and loading.



④ Interconnected access

The left, right, and center access points are interconnected, making maintenance and servicing more convenient.



XE950DA

Hydraulic excavators are suitable for various working conditions

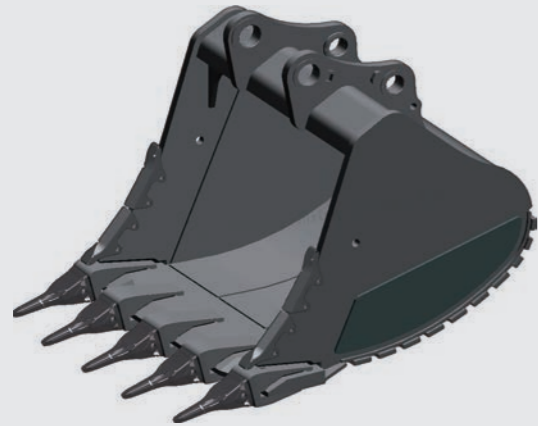

Bucket type	Bucket capacity m ³	Fill rate %	Weight per backhoe kg	Applicable material density kg/m ³
				boom: 7.25m arm: 2.92m
Light-duty excavation	7.0	100	5700	1500
Heavy-duty excavation	6.2	90	5500	1800
	5.4	90	6600	2100

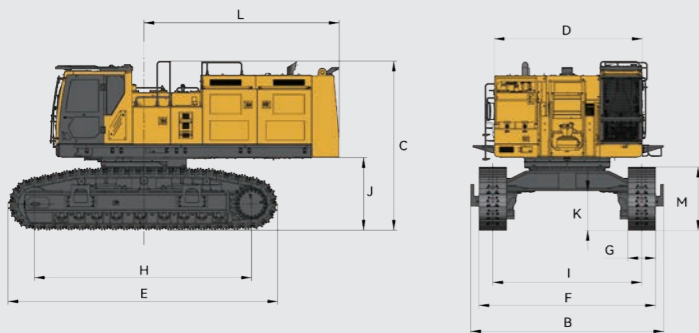

Technical specifications

Model	UOM	Parameters
Outline dimensions		
A Overall length	mm	14050
B Overall width	mm	4550
C Overall height	mm	5150
D Turntable width	mm	3490
E Track length	mm	6360
F Total width of chassis	mm	4160
G Track width	mm	650
H Track wheel base	mm	5120
I Track gauge	mm	3510
J Counterweight ground clearance	mm	1660
K Minimum ground clearance	mm	870
L Minimum tail swing radius	mm	4700
M Track height	mm	1487
Optional device		
Device bucket	m ³	5.4 (Earthmoving bucket) 6.2 (rock bucket)
Capacity		Engine cooling start

Technical updates and changes will not be notified separately.

Body Layout

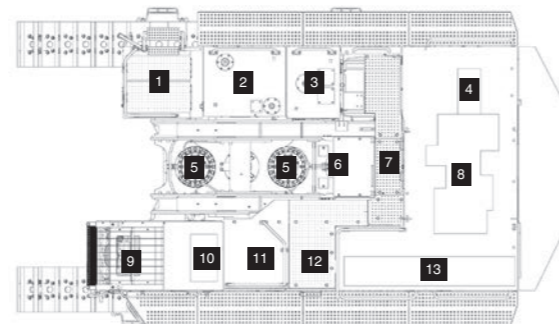

- 1 Toolbox (Storage location for random tools)
- 2 Fuel tank
- 3 Hydraulic oil tank
- 4 Main pump, cooling pump (utilizing dual independent cooling pumps for precise control and improved energy saving)
- 5 Slewing system (using a large displacement motor for high slewing torque)
- 6 Main valve (using customized main valve with low pressure loss and high efficiency)
- 7 Middle channel (with easy maintenance, filter element located on both sides, within reach)
- 8 Engine (equipped with Cummins QSM15 engine, low fuel consumption and high reliability)
- 9 Cab driver's cab (positive pressure cab with low noise)
- 10 Air Conditioner (heating and cooling air conditioner)
- 11 Electrical cabinet (equipped with 4 large-capacity batteries, strong start ability at low temperature)
- 12 Air filter (radial seal large-capacity air filter with long maintenance cycle)
- 13 Radiator (using parallel radiators suitable for 50°C high temperature environments)

XE950DA

Schematic diagram of loading ratio for mining hydraulic excavators paired with mining dump trucks

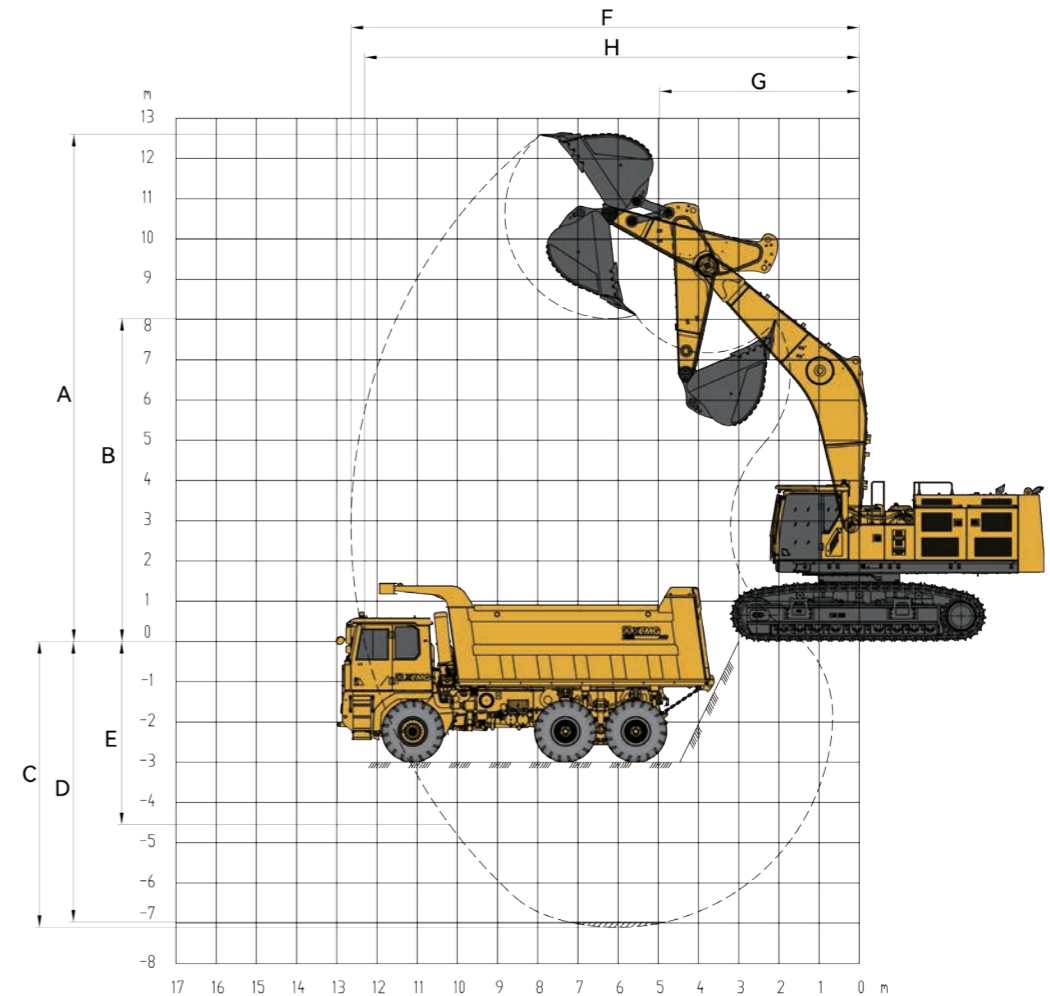

Working areas

Model	UOM	Parameters
Working Range		
A Maximum digging height	mm	12600
B Maximum dump clearance	mm	8025
C Maximum digging depth	mm	7160
D Depth of excavation at 8-foot horizontal plane	mm	7025
E Maximum vertical digging depth	mm	4600
F Maximum digging radius	mm	12645
G Minimum swing radius	mm	4970
H Maximum digging radius on horizontal surface	mm	12315

XE950DA

HYDRAULIC EXCAVATOR OPERATION LIFTING CAPABILITY TABLE

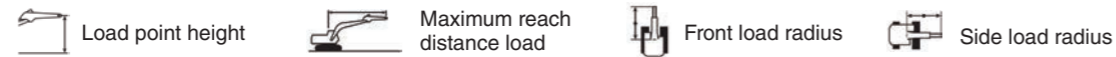

		Boom — 7.25m Arm — 2.92m				Bucket — none Track shoe — 650mm						
		4.5m		6.0m		7.5m		9.0m		m		
10.5m	kg									*19950	*19950	6.38
9.0m	kg					*22200	*22200			*18250	*18250	7.87
7.5m	kg					*24000	*24000			*17450	*17450	8.87
6.0m	kg	*39250	*39250	*30050	*30050	*25250	24500	*22400	18450	*17400	16800	9.52
4.5m	kg			*33400	32550	*26850	23500	*23000	17900	*17800	15450	9.90
3.0m	kg			*35900	30800	*28200	22500	*23550	17400	*19000	14850	10.03
1.5m	kg			*36500	29700	*28750	21750	*23600	16950	*20550	14800	9.94
地面	kg	*27900	*27900	*35150	29300	*28050	21350	*22700	16750	*20550	15350	9.61
-1.5m	kg	*38700	*38700	*32050	29300	*25800	21300	*19900	16800	*19850	16750	9.02
-3.0m	kg	*31650	*31650	*26750	*26750	*21100	*21100			*18300	*18300	8.10
-4.5m	kg			*17600	*17600					*16500	*16500	6.30

ATTENTION

- 1.* Indicates the load is limited by hydraulic lift capacity rather than tipping load.
2. The weight of the lifting chain and some auxiliary lifting equipment should be deducted from the rated load to calculate the net lifting load. Lift capacity should be determined based on the excavator being on a solid and level ground surface. Users should take into account working conditions such as soft or uneven terrain.
3. Before operating the machine, the operator should be thoroughly familiar with the User Manual and Safety Operation Manual provided by the manufacturer.
4. The above loads comply with ISO 10567:2007 Earth-moving machinery-Hydraulic excavators-Lift capacity. The displayed working capacity does not exceed 75% of the tipping load or 87% of the hydraulic lift capacity.
5. The above-mentioned net lifting load has ±5% error margin.
6. Operational capacity applies only to machines that are originally manufactured by the manufacturer and are assembled by the manufacturer in accordance with normal procedures.

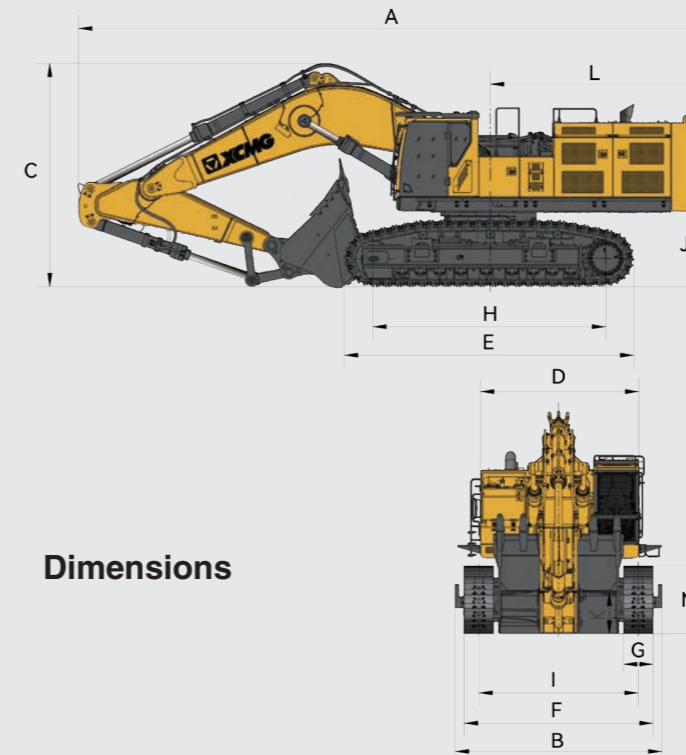

Dimensions

Working Areas

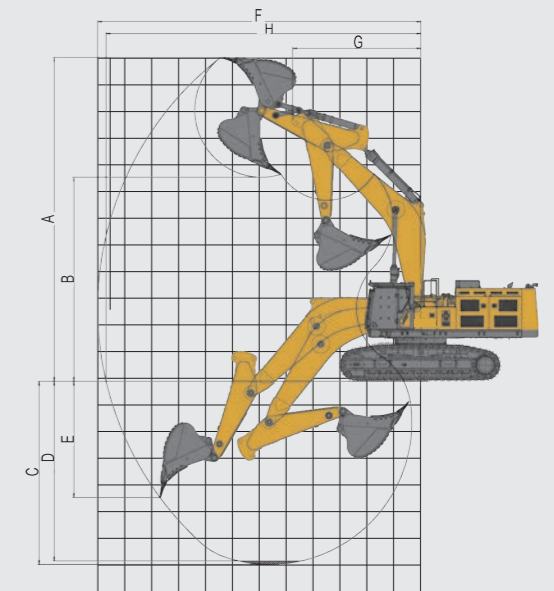

Technical specifications

Model	UOM	Parameters
Operating weight	Kg	95000
Bucket capacity	m³	5.4-7.0
Boom length	mm	7250
Arm length	mm	2925
Engine		
Engine model	/	2806C
Direct injection	/	√
4 Stroke	/	√
Water cooling	/	√
Turbocharging	/	√
Air-to-air intercooler	/	√
Number of cylinders	/	6
Engine output	kw/rpm	570.5/2100
Maximum torque/rotation speed	N·m	3496/1400
Displacement	L	18.1
Main performance		
Travel speed	km/h	4.4/2.8
Slewing speed	r/min	6.5
Grade ability	°	35
Ground pressure	kPa	139
Bucket digging force	kN	490
Arm digging force	kN	425
Max. traction	kN	585
Hydraulic system		
Main pump	Hydraulic system	2 plunger pumps
Main pump rated flow	L/min	2x504
Main safety valve pressure	MPa	37.3
Travel system pressure	MPa	35
Slewing system pressure	MPa	32
Pilot system pressure	MPa	3.9
Oil capacity		
Fuel tank capacity	L	1200
Volume of hydraulic oil tank	L	540
Engine oil capacity	L	65
Coolant volume	L	58

XE950DA

Hydraulic Excavator

Technical specifications

Equipment	XE950DA Hydraulic Excavator		
Working device			
Boom 7.25m	√		
Arm 2.925m	√		
7.0m ³ reinforced bucket	√		
5.4m ³ rockbucket		○	
6.2m ³ rockbucket		○	
Rock boom		○	
Driver's cab			
Pressurized driver's cab	√		
High resolution (600x1,024) color LCD touchscreen display showing warnings and others	√		
Fully adjustable air suspension seat	√		
Adjustable seat armrest	√		
Seat belt (51mm [2"] width)	√		
Bidirectional air conditioner with defroster (automatic type) (pressurized function)	√		
Control levers	√		
Driving control pedal equipped with detachable manual joystick	√		
Washable mat	√		
Air conditioning system	√		
High and low speed shifting	√		
24V DC power interface	√		
12V DC power interface	√		
Sun screen	√		
Top sunroof	√		
Windshield wiper	√		
Cup holder/Document bag	√		
Radio receiver (including USB, AUX ports)	√		
Fire extinguisher		○	
Safety and protective devices			
Fuel tank lock	√		
Rearview mirror kit	√		
Signal/Alarm horn	√		
Engine emergency stop switch accessible from ground level	√		
Engine emergency stop switch in driver's cab	√		
Driver's cab door lock and cabin locks	√		
Isolation panel between the engine and oil pump chamber	√		
Emergency exit at the rear window	√		
Boom and arm holding valve	√		
Overheat alarm	√		
Safety handrail and pedal	√		
Beacon light	√		
Anti-slip plate/Anti-slip sticker	√		
Hydraulic safety locking rod	√		
Emergency escape hammer	√		
Rearview surveillance camera	√		
Falling object protective structure (FOPS)	√		
Front lower guard net of driver's cab	√		
360° full-view image system		○	
Front upper guard net of driver's cab		○	
automatic fire extinguishing system		○	
Driver behavior monitoring system		○	
Maintenance and service			
Lubrication centralized filling system for boom and arm	√		
Reversible cooling fan	√		
Electric lubrication system		○	
Engine			
Oil-water separator with water level indicator sensor	√		
Automatic control of engine speed	√		
Radial seal air filter	√		
50°C High-temperature cooling unit	√		
Start ability at low temperature -20°C	√		
Two selectable modes: Power mode, standard mode	√		
Fuel breather valve	√		
Air differential pressure sensor	√		
Automatic idle	√		
Maximum usage B40 grade biodiesel	√		

√: Standard

○: Optional

XE950DA

Hydraulic Excavator

Technical specifications

Equipment	XE950DA Hydraulic Excavator		
Engine			
Start ability at ultra-low temperature -30°C		○	
Quick fuel filling system		○	
Quick engine oil filling system		○	
Hydraulic system			
Electric control main valve	√		
Boom/Arm fow regeneration	√		
Reverse swing damping	√		
Automatic swing parking brake	√		
Straight hydraulic circuit	√		
Boom priority valve	√		
Swing logic valve	√		
ISO/JIS operation mode switching	√		
Swing anti-sway valve	√		
Spare valve disc	√		
Instrument pressure monitoring	√		
Hydraulic circuit: breaker hammer		○	
Quickhydraulic oil filling system		○	
Chassis system and shield			
Undercarriage tow ring	√		
Protection device kit: chassis bottom cover plate, travel motor cover plate	√		
650 mm (24") Double-rib trackshoe	√		
Extended variable trackgauge chassis	√		
Full-length trackguard	√		
Grease lubrication and tensioning device	√		
750 mm (28") Double-rib trackshoe		○	
900 mm (31") Double-rib trackshoe		○	
Electrical system			
Maintenance-free batter (4 x950 CCA)	√		
Batter circuit breaker	√		
Travel alarm	√		
LED worklights of booms on both sides	√		
LED worklight mounted on the right side of the storage box	√		
Interior lighting of driver's cab	√		
Front LED worklight installed on the roof of driver's cab	√		
Rear LED worklight installed on the roof of driver's cab	√		
LED maintenance light of pump chamber	√		
LED maintenance light of power cabin	√		
Control technology			
XEICS intelligent control system	√		
Bluetooth system	√		
Diagnostic recorder	√		
Data linksocket	√		
Engine diagnostic testing equipment		○	
Remote driving		○	

Notes:

- The graphics and information in this brochure reflect the technical features and standard configurations of certain models at the time, with existing information and data derived from standard usage tests. The above data and information are for reference only; please refer to the actual product.
- This brochure is for reference only and does not have contractual validity. For detailed information, please contact your local dealers of XCMG Mining Machinery.
- Without authorization from Xuzhou XCMG Mining Machinery Co., Ltd., the content of this brochure may not be reproduced. Xuzhou XCMG

Mining Machinery Co., Ltd. reserves the right of interpretation and the right of modification for this brochure.