



Accelerometer

AXE-STD-LR-2, version 5.0



INSTALLATION & OPERATION MANUAL

Safety, Compliance and Warranty Information

Rev.3

Move S.p.A.

VAT / P.IVA: 09887990969

REGISTERED OFFICE

Piazza Cavour, 7, 20121 Milan - Italy

MOVE SOLUTIONS CUSTOMER ASSISTANCE SERVICE

Visit the website at www.movesolutions.it for contact information relating to office addresses and phone numbers.



Accelerometer

INSTALLATION & OPERATION MANUAL

This document applies to:

AXE-STD-LR-2, version 5.0

© 2026 Move S.p.A. All rights reserved.

Manual drafted in Italy

2 April, 2026

Revision 3

NOTICE OF PUBLICATION

The information contained in this manual may be subject to change without notification. For further instructions, more detailed information, product specifications and to download up-to-date manuals, visit our website at www.movesolutions.it

Index

1. Regulatory and safety information	6
WEEE Compliance	8
FCC Compliance	8
ISED Compliance	9
Symbols and provisions used in the documentation	10
2. General description	11
2.1 Output data	11
3. Technical data	13
3.1 Battery life estimation	17
4. What's in the box	18
5. Before installation	21
5.1 Axis configuration	21
5.2 Why change the longitudinal axis?	25
5.3 Schematics for each possible Accelerometer orientation	26
5.4 Optimizing radio performance	33
6. Installation	35
6.1 Standard mounting plate	35
6.2 L-shaped mounting plate	37
7. MyMove platform	40
8. Working principle	41

9. Maintenance	43
10. Overall dimensions	44
Annex A. Troubleshooting	50

Regulatory and safety information

For the correct and safe operation of the product, it is recommended to read and follow the instructions in this manual.

The device is designed and intended exclusively for the monitoring of dynamic parameters, including vibrations, accelerations, and structural movements, within civil, industrial, and environmental engineering applications. The device is intended to be installed on structures such as buildings, infrastructure, geotechnical works, or machinery, in order to collect data for structural health assessment, predictive maintenance, and evaluation of operating conditions.

The product is supplied exclusively on a business-to-business (B2B) basis and is not intended for sale or use by private consumers. Installation, configuration, operation, and maintenance of the device must be carried out solely by qualified and trained personnel with appropriate technical expertise.

The product must be used in accordance with Move Solutions' technical specifications, within the declared environmental and operational conditions, and in combination with compatible communication systems (e.g. LoRaWAN networks). Any use other than that described above shall be considered non-compliant with the intended use of the device.

Great attention should be paid to the following warnings. Move Solutions shall not be held responsible for inconveniences, damage or malfunctions due to lack of compliance to the prescriptions and suggested use in this manual.

- The declared IP rating is guaranteed only when the product is correctly assembled, with the lid properly screwed in place, the antenna installed, and the Move Link connector protected either by a properly connected external cable or by the supplied protective cap when no cable is present.
- Before use, make sure that the product conforms to the description in this manual and that no damage is present.
- Do not use batteries other than those specified by Move Solutions without express approval from a Move Solutions representative.
- Before any operation on the product, disconnect the batteries.
- The product is not intended for use in applications where safety is extremely critical, such as medical-related applications or life-security systems.
- On top of the prescriptions in this manual, the user should operate in compliance with

local standards for security and health, and according to the best engineering practices for a safe installation.

- The product must be kept clear of children, animals, and any unauthorized personnel.
- Do not disassemble the product except when explicitly instructed in this manual, as this could cause malfunctions and damage the product.
- Do not attempt to repair or modify the product.
- If the product releases smoke or heat during operation, immediately disconnect the batteries.
- Do not expose the product to high temperatures outside the specified range or heat sources.
- Do not expose the product to liquids of any kind and do not operate on it with wet hands. The product can only be exposed to water when the conditions to guarantee the IP rating are satisfied.
- Do not operate on the product in extreme weather conditions that may damage the device or the user, such as thunderstorms or snowstorms.
- Do not disperse the product or part of it in the environment.
- Correct functioning of the product in environments with high radio activity is not guaranteed.
- The product is compliant to all regulations concerning the fair use of ISM radio bands. However, given the free nature of these bands, occasional conflict with nearby devices operating on the same bands cannot be fully prevented.
- Measurements provided by the device are intended for informational purposes only. Move Solutions shall not be liable for any structural assessment, safety certification, or engineering decisions made by the user based on the data collected.
- The user acknowledges that wireless communication (e.g. LoRaWAN) is subject to environmental interference and network availability. Move Solutions does not guarantee 100% data delivery and is not responsible for any data loss or transmission delays.

NOTE

In case of deterioration or loss of this manual, a compliant copy may be requested by the customer from the manufacturer. For increased security, we suggest that you keep a copy of this manual in a place where it cannot be damaged or lost.

WEEE Compliance

This product contains electronic components and batteries that must be disposed of separately from common household waste, according to local regulations. To ensure correct disposal of the product at the end of its lifecycle, please contact your local authority. Failure to comply with these regulations could lead to penalties.



This product is registered in the Italian WEEE Register under number IT25110000017837, in accordance with Directive 2012/19/EU on Waste Electrical and Electronic Equipment (WEEE).

FCC Compliance

This device complies with part 15 of the FCC Rules. Operation is subject to the following two conditions: (1) This device may not cause harmful interference, and (2) this device must accept any interference received, including interference that may cause undesired operation.

FCC Caution: Changes or modifications not expressly approved by the party responsible for compliance could void the user's authority to operate the equipment.

NOTE

This equipment has been tested and found to comply with the limits for a Class B digital device, pursuant to part 15 of the FCC Rules. These limits are designed to provide reasonable protection against harmful interference in a residential installation. This equipment generates, uses and can radiate radio frequency energy and, if not installed and used in accordance with the instructions, may cause harmful interference to radio communications. However, there is no guarantee that interference will not occur in a particular installation. If this equipment does cause harmful interference to radio or television reception, which can be determined by turning the equipment off and on, the user is encouraged to try to correct the interference by one or more of the following measures:

- Reorient or relocate the receiving antenna.
- Increase the separation between the equipment and receiver.
- Connect the equipment into an outlet on a circuit different from that to which the receiver is connected.
- Consult the dealer or an experienced radio/TV technician for help.

Contains FCC ID: 2A3LJ-MAMWLE

ICES-ISED Compliance

This device complies with Innovation, Science and Economic Development Canada's (ISED) licence-exempt RSS standard(s). Operation is subject to the following two conditions:

- (1) this device may not cause interference, and
- (2) this device must accept any interference, including interference that may cause undesired operation of the device.

Le présent appareil est conforme aux CNR d'Innovation, Sciences et Développement économique Canada applicables aux appareils radio exempts de licence. L'exploitation est autorisée aux deux conditions suivantes:

- (1) l'appareil ne doit pas produire de brouillage, et
- (2) l'utilisateur de l'appareil doit accepter tout brouillage radioélectrique subi, même si le brouillage est susceptible d'en compromettre le fonctionnement.

This equipment complies with Innovation, Science and Economic Development Canada radiation exposure limits set forth for an uncontrolled environment.

Cet équipement est conforme à l'exposition aux rayonnements Innovation, Sciences et Développement économique Canada limites établies pour un environnement non contrôlé.

This Class B digital apparatus complies with Canadian ICES-003.

Cet appareil numérique de la classe B est conforme à la norme NMB-003 du Canada.

CAN ICES-003(B)/NMB-003(B)

Contains IC: 28058-MAMWLE

Contient IC: 28058-MAMWLE

Symbols and provisions used in the documentation

The following symbols and conventions are used throughout Move Solutions products documentation. Please follow all warnings and instructions marked on the product.



WARNING

WARNING indicates a potentially hazardous situation which, if not avoided, can result in minor or moderate injury.



Fire Danger icons warn of the possibility of fire.



Electrical Danger icons warn of the risk of electric shock.



IMPORTANT

IMPORTANT indicates a potentially hazardous situation which, if not avoided, can result in property damage or loss of product functionality.



Prohibition icons indicate actions that must not be performed.

NOTE

NOTE specifies the operating environment, installation conditions, or special conditions of use.

Bold

Highlights an important point or keywords for understanding the context.

Underlined

Denotes a reference to another part of the documentation or to an element within MyMove platform.

General description

2

The Accelerometer measures acceleration data expressed in “g” unit on the three orthogonal axes at the selected sample rate, and it can be synchronized with other Accelerometers for Modal Analysis.

Part of the Move Solutions sensor family, it integrates seamlessly with the MyMove platform.



2.1 Output data

The sensor provides information about vibrational activity of the structure in which it is installed, by measuring the dynamic acceleration on the three axes. To do so acceleration data is high pass filtered to remove the continuous component due to gravity.

The input acceleration data is sampled over time and saved into the internal data buffer, whose depth is selectable by the user. The data collected is used to provide the RMS and peak values for the event. Moreover, for Standard trigger and Programmed modes, the sensor also provides the full waveform.

The sensor also records the temperature at measurement time.

The Accelerometer is part of the Move Solutions range of LoRaWAN products for monitoring purposes; as such, it needs a LoRaWAN Gateway in its range (such as the Move Solutions Gateway Pro) to connect to the MyMove platform. When the sensor is connected to the platform, the settings and data can be personalized to fit the user's needs.

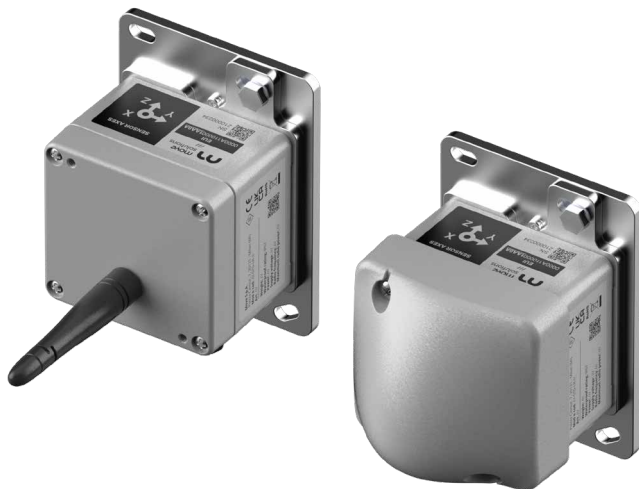
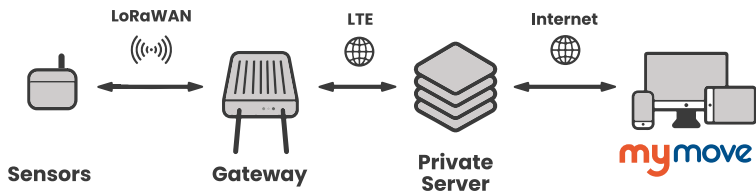

Technical data

Measurement performances						
Sensing technology	MEMS accelerometer (3 axes)					
Noise density	22.5 $\mu\text{g}/\sqrt{\text{Hz}}$					
Sampling frequency and Bandwidth ¹	Sampling frequency	Low Bandwidth limit		High bandwidth limit		
	40 Hz	0.15 Hz		15.625 Hz		
	80 Hz	0.3 Hz		31.25 Hz		
	160 Hz	0.15 Hz		62.5 Hz		
	320 Hz	0.3 Hz		125 Hz		
	640 Hz	0.15 Hz		250 Hz		
Full scale range and resolution	Full scale range		Resolution			
	± 128 mg		3.90625 μg			
	± 256 mg		7.8125 μg			
	± 512 mg		15.625 μg			
	± 1.024 g		31.25 μg			
	± 2.048 g		62.5 μg			
	± 4.096 g		125 μg			
	± 8.192 g		250 μg			
Data buffer depth ² Total / pre-trigger ³	Number of samples	Duration v/s Sampling Frequency				
		40 Hz	80Hz	160 Hz	320 Hz	640 Hz
	128 (11)	3.2/0.26 s	1.6/0.14 s	0.8/0.07 s	0.4/0.03 s	0.2/0.02 s
	256 (21)	6.4/0.51 s	3.2/0.26 s	1.6/0.13 s	0.8/0.07 s	0.4/0.03 s
	512 (41)	12.8/1.03 s	6.4/0.51 s	3.2/0.26 s	1.6/0.13 s	0.8/0.07 s
	1024 (82)	25.6/2.05 s	12.8/1.03 s	6.4/0.51 s	3.2/0.26 s	1.6 / 0.13 s
	2048 (164)	51.2/4.1 s	25.6/2.05 s	12.8/1.03 s	6.4/0.51 s	3.2/0.26 s
	4096 (328)	102.4/8.2 s	51.2/4.1 s	25.6/2.05 s	12.8/1.03 s	6.4/0.51 s
	8192 (656)	204.8/16.4 s	102.4/8.2 s	51.2/4.1 s	25.6/2.05 s	12.8/1.03 s
16384 (1311)	409.6/32.8 s	204.8/16.4 s	102.4/8.2 s	51.2/4.1 s	25.6/2.05 s	

Measurement performances	
Operating modes	Programmed acquisition
	Fast Trigger acquisition
	Standard Trigger acquisition
	Programmed acquisition + Fast Trigger ⁴
Cadence for programmed acquisitions	30 minutes
	1 hour
	2 hours
	3 hours
	4 hours
	6 hours
	8 hours
	12 hours
Timestamp accuracy ⁵	± 1 s
Synchronization accuracy between sensors in Programmed mode	≤ 500 μs
Temperature resolution	0.05 °C
Temperature accuracy	0.2 °C
Internal storage memory ⁶ (circular)	Up to 60000 events including waveform
	Up to 250000 events not including waveform

¹ Down sampled from a main sampling frequency of 4 kHz

² In case of Fast Trigger and Standard Trigger acquisitions includes both pre-trigger and post-trigger buffers.

³ Pre-trigger only applies to Fast Trigger and Standard Trigger modes.

⁴ If more modes are enabled at the same time, their performance may be reduced. To achieve the best performances for each mode, please avoid using combined mode.

⁵ Under good LoRaWAN radio coverage.

⁶ The actual memory capacity may vary depending on sensor configuration and input signal characteristics.

Waveform data transmission duration ^{1,2,3}	
128 samples	10 s
256 samples	15 s
512 samples	25 s
1024 samples	45 s
2048 samples	1 m 20 s
4096 samples	2 m 30 s
8192 samples	5 m
16384 samples	10 m

¹ The estimation refers to a sensor in a typical working environment with good quality radio connection between the sensor and the Gateway. It also refers to an input signal (acceleration) whose value does not exceed 25% of full scale.

² The estimation is valid for all sampling frequencies (40 Hz, 80 Hz, etc.).

³ The transmission duration is considered starting from the event start until the last packet is sent to the MyMove platform.

General data	
Wireless connection technology	Sub-GHz LoRaWAN protocol ¹ (Gateway required)
Wireless coverage ²	1 km line of sight from the nearest Gateway
Connections	Move Solutions 8-pole connector. For compatible accessories visit Move Solutions' website or contact support.
IP rating ³	IP67
Power supply	1x 19Ah 3.6V replaceable lithium battery (D-type LiSOCl ₂ with JST EHR-2 connector, suggested EVE ER34615 EHR2)
Operating temperature range	From -40 °C to +85 °C
Dimensions ⁴	97.5 x 80.5 x 66 mm

General data	
Weight ⁴	0.5 kg
Package weight	0.8 kg
Case material	GD-ALSi12 alloy
Installation options	Wall, floor, or ceiling mount. Two-points attachment using screw anchors (Ø6mm max). One set included in the package.
Software version	v5

¹ The sensor's LoRaWAN connection operates on a best-effort basis, which means that while most data packets are delivered, there is a slight possibility of occasional packet loss.

² Wireless coverage may vary based on the actual deployment scenario.

³ The declared IP rating is guaranteed only when the product is correctly assembled, with the lid properly screwed in place, the antenna installed, and the Move Link connector protected either by a properly connected external cable or by the supplied protective cap when no cable is present.

⁴ Refers to the sensor unit itself. External accessories, such as mounting plate, short antenna and protective dome for the antenna are not considered since they are optional and/or can be replaced with alternative parts to fit specific applications.

3.1 Battery life estimation

Configuration ^{1,2}	Internal battery only	with Battery Pack (combined) ³
Programmed acquisition with 30 minutes period Data buffer depth: 4096, Sampling Frequency: 80 Hz	1 year	3 years and 3 months
Programmed acquisition with 1 hour period Data buffer depth: 4096, Sampling Frequency: 80 Hz	2 years	5 years and 9 months
Programmed acquisition with 6 hours period Data buffer depth: 4096, Sampling Frequency: 80 Hz	8 years	13 years and 5 months
Standard Trigger acquisitions ⁴ (including waveform), 5 events/hour Data buffer depth: 1024, Sampling Frequency: 80 Hz	1 year	3 years and 3 months
Fast Trigger acquisitions ⁴ (without waveform), 5 events/hour Data buffer depth: 1024, Sampling Frequency: 80 Hz	4 years	9 years and 3 months

¹ Configuration parameters that are not specified are to be considered in their default configuration.

² The estimation refers to a sensor in a typical working environment with average quality of the radio connection between the sensor and the Gateway. Actual battery life may be worse in case the product is used under extreme conditions, such as prolonged working in high or low temperatures, bad quality of radio connection between the sensor and the Gateway, etc.

³ Battery Pack sold separately.

⁴ The consumption of trigger acquisitions depends on the actual input signal of the sensor and its configuration, so it may differ from the stated.

What's in the box

The Accelerometer is shipped in a cardboard box. On the side of the box, a label is affixed with the **EUI** and **Serial Number** of the product. The EUI uniquely identifies the sensor on the **MyMove** platform and must be retained for configuration and registration purposes. The package contains the following items:

- Accelerometer
- External antenna (supplied as a separate component, depending on the ordered configuration)
- Move Solutions flyer with a QR code linking to the most up-to-date documentation

Mounting anchors are also supplied.

Carefully inspect the contents of the shipment upon receipt and verify that all components are present and in good condition.

**WARNING**

DO NOT use the Accelerometer if any of the components looks broken or tampered with.

MOUNTING PLATES AND PROTECTIVE DOME

Depending on the ordered configuration, the Accelerometer may be supplied with either a standard mounting plate or an L-shaped mounting plate and with or without a protective dome. Installation procedures and illustrations may vary slightly according to the installed mounting plate. When the protective dome is not installed, the sensor is supplied with a separate external standard antenna.

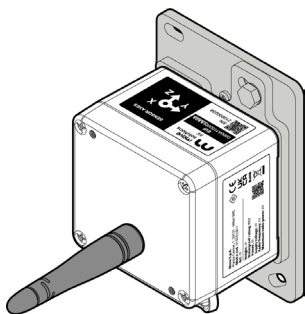

Configuration 1 - Standard mounting plate, with standard antenna.

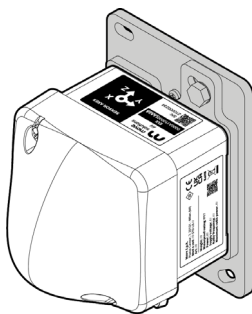

Configuration 2 - Standard mounting plate, with short antenna and protective dome.

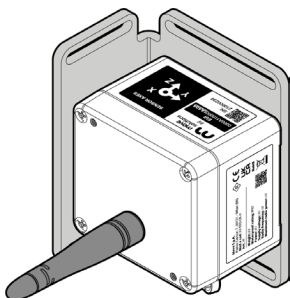

Configuration 3 - L-shaped mounting plate, with standard antenna.

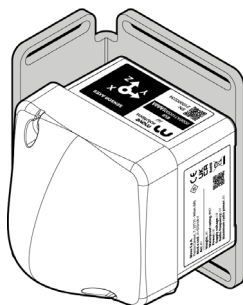

Configuration 4 - L-shaped mounting plate, with short antenna and protective dome.

Two labels bearing the same information as the one on the packaging are affixed on the side of the Accelerometer. From the outside you'll see:

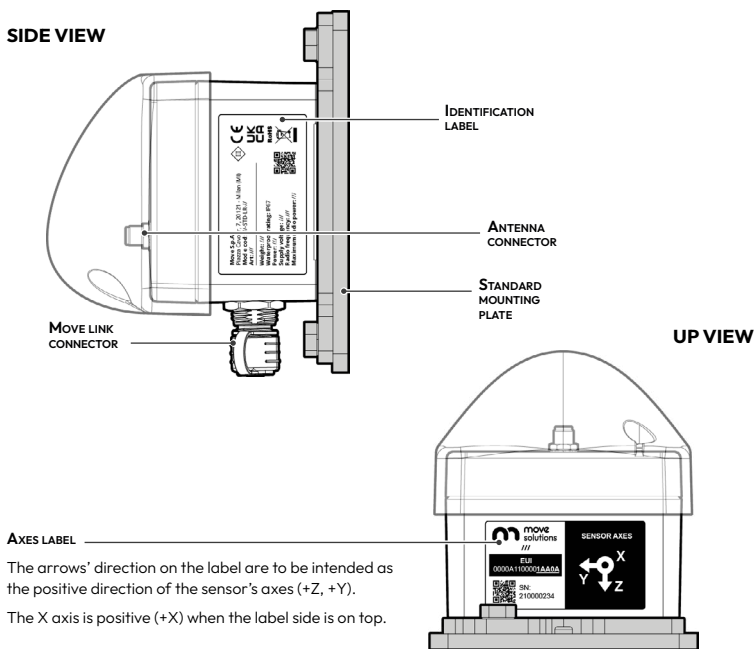

IMPORTANT

- **DO NOT** unbox or expose the Accelerometer in dusty and/or humid environments. The declared IP rating is guaranteed only when the product is correctly assembled, with the lid properly screwed in place, the antenna installed, and the Move Link connector protected either by a properly connected external cable or by the supplied protective cap when no cable is present.
- **DO NOT** loosen or tighten the screws of the Accelerometer as this could alter the product's IP rating.

Before installation

5.1 Axis configuration

By default, the sensor's LONGITUDINAL axis (L) is set to be +Y and the TRANSVERSAL axis (T) is +Z, with the VERTICAL axis (V) being +X.

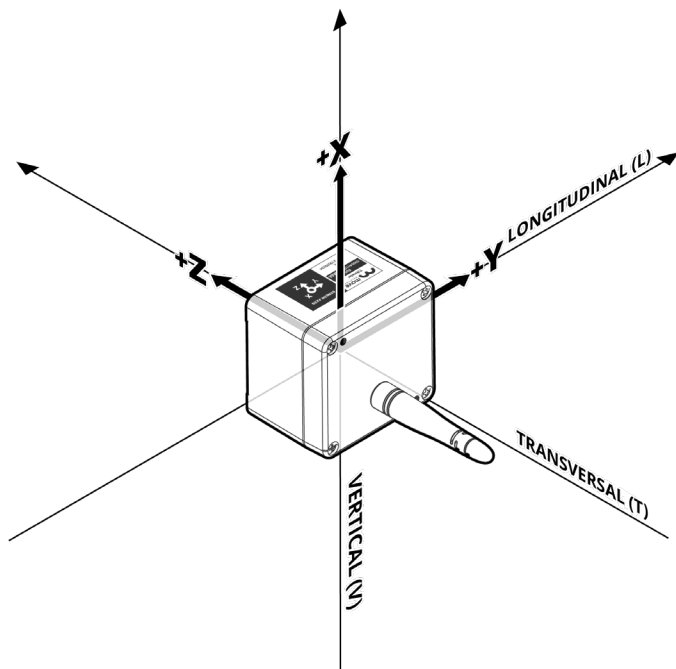

The association between the (X, Y, Z) and (L, T, V) axis systems can be configured on the MyMove platform, allowing the user to define a unified axis representation in which both reference systems are mapped onto the same structural axes.

VERTICAL AXIS CONFIGURATION

It's important to be aware, during installation, which one of the three axes of the sensor (out of X, Y and Z) is VERTICAL and in which direction (point up or pointing down). The proper configuration of this parameter is crucial for the sensor's correct functioning.

By default, the sensor is set to have **+X as VERTICAL (V)** (X axis, pointing up). Installing the sensor in that position is preferable, in order to avoid a configuration step (setting a different VERTICAL axis on MyMove platform).

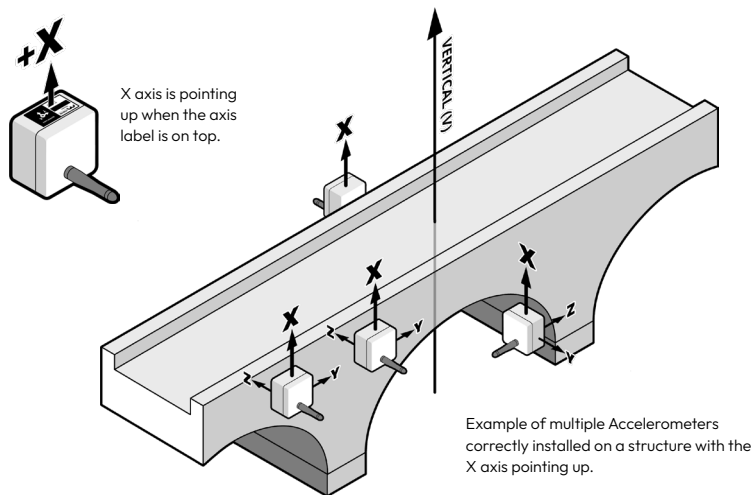

IMPORTANT

In case it was not possible to install the sensor with the X axis pointing up, the user will have the possibility to configure, from MyMove platform, the axis of the sensor associated with VERTICAL.

LONGITUDINAL AXIS CONFIGURATION (OPTIONAL)

Once the VERTICAL axis is properly configured, changing the axis associated to LONGITUDINAL is not a required configuration step.

This step is needed in two occasions:

- **VERTICAL axis is different from default (+X)**
- **To ensure consistent axis alignment across sensors on the same structure**

Check the chapter [5.2 Why changing the longitudinal axis?](#) for more details.

NOTE

When associating the axis of the sensor to LONGITUDINAL and TRANSVERSAL, for every axis the two options + and - are available (example: +Y and -Y).

If +Y is set as LONGITUDINAL it means that the positive (+) direction of Y is associated with LONGITUDINAL. If -Y is set as LONGITUDINAL it means that the negative (-) direction of Y axis is associated with LONGITUDINAL.

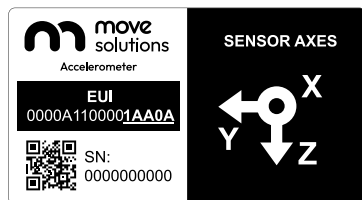
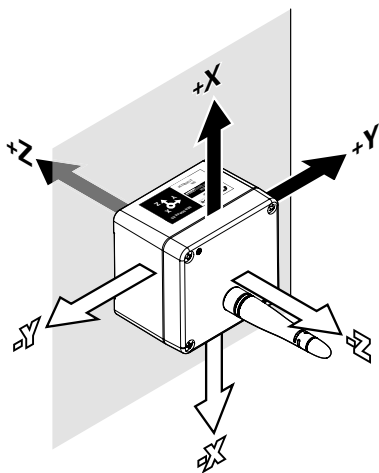

Refer to the axes label on the top side of the Accelerometer to identify the axes positions and directions. The arrows direction indicate the positive side of its axis (+X, +Y, +Z).

Consequently the directions opposite to the arrows can be identified as the negative side of the axes (-X, -Y, -Z).

Default configuration

By default, the axes configuration is **FIG.1**:

- LONGITUDINAL (L) associated with +Y
- TRANSVERSAL (T) associated with +Z

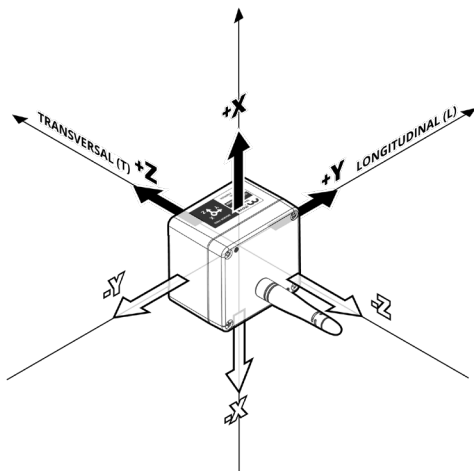

FIG.1
DEFAULT CONFIGURATION

Structure axis	L	T	V
Sensor axis	+Y	+Z	+X

Alternative configuration

Modifying the LONGITUDINAL and TRANSVERSAL axes configuration means associating different axes to them. An example of an alternative configuration would be **FIG.2**:

- LONGITUDINAL (L) associated with +Z
- TRANSVERSAL (T) associated with -Y

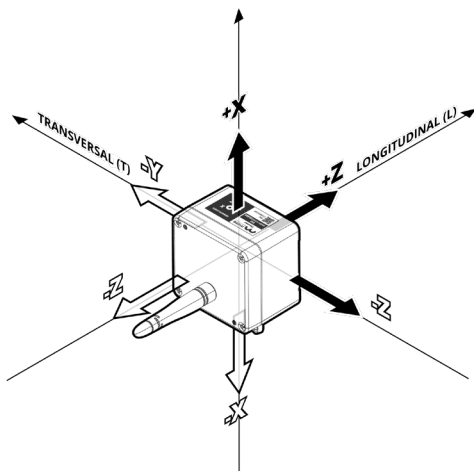

FIG.2
ALTERNATIVE CONFIGURATION

Structure axis	L	T	V
Sensor axis	+Z	-Y	+X

5.2 Why change the longitudinal axis?

The two situations that make it necessary to modify that parameter are:

1. **VERTICAL axis is different from default (+X):** in this scenario it's necessary to identify new LONGITUDINAL and TRANSVERSAL axes.
2. **Axis alignment across a structure:** if multiple sensors are installed on the same structure with different axis orientations, it may be necessary to adjust the axes associated with LONGITUDINAL and TRANSVERSAL on some sensors. In this way, the LONGITUDINAL and TRANSVERSAL axes of each sensor are aligned and consistently represent those of the entire structure.

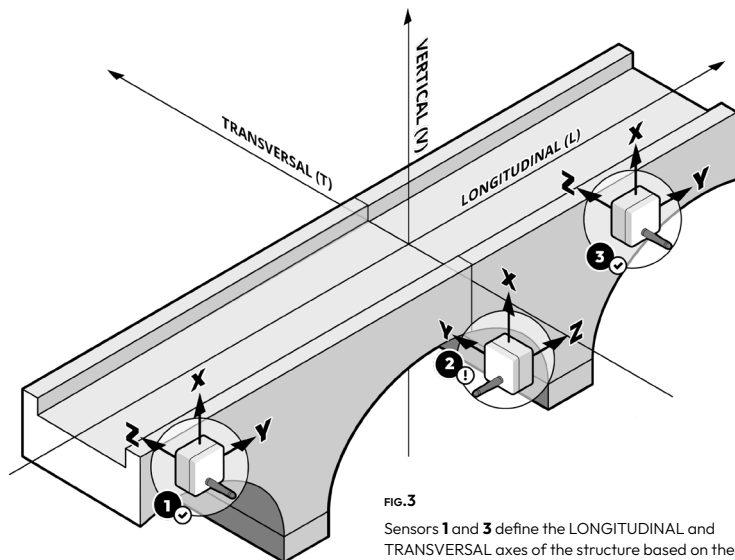

FIG.3

Sensors 1 and 3 define the LONGITUDINAL and TRANSVERSAL axes of the structure based on their position. Sensor 2 is installed with a different orientation compared to Sensors 1 and 3. You can adjust the axes assignment of Sensor 2 on MyMove platform, to align with the other sensors.

5.3 Schematics for each possible Accelerometer orientation

As already mentioned, you can change the orientation of the sensor axes from the **MyMove** platform. To do this, follow the steps below:

1. In **MyMove** once you're on a project dashboard, use the lateral menu to navigate to Settings > Devices.
2. Locate and select the device you want to configure, then click **Edit settings**. A side panel titled Device settings will appear.
3. In the side panel, click **Operation**.
4. Under the Operation section, open the **Advanced Settings** accordion.

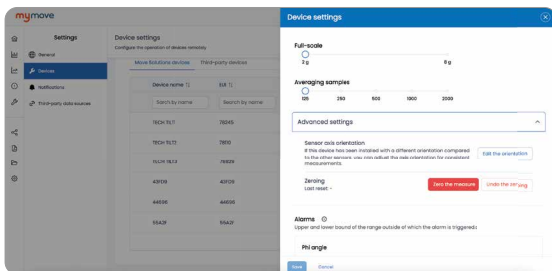

5. From here, you can access the Sensor axis orientation editor to adjust the sensor axes.

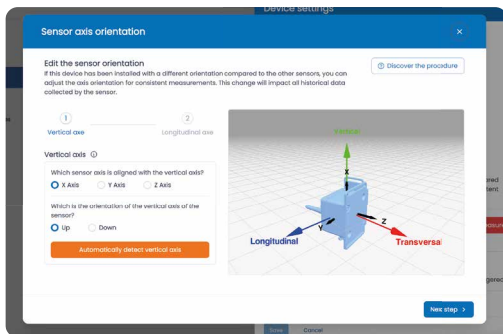

A. X axis pointing upwards (+X as VERTICAL)

The figure alongside illustrates the Accelerometer in its standard reference orientation. In the subsequent examples, the axis reorientation procedure is demonstrated with respect to a reference Accelerometer.

Keep in mind that there is no universal standard for assigning the LONGITUDINAL or TRANSVERSAL axis of the structure. A practical recommendation is to adopt as the reference orientation the position in which the majority of your Accelerometers are installed.

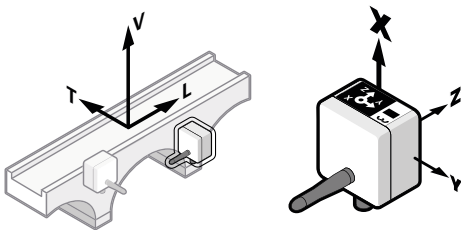
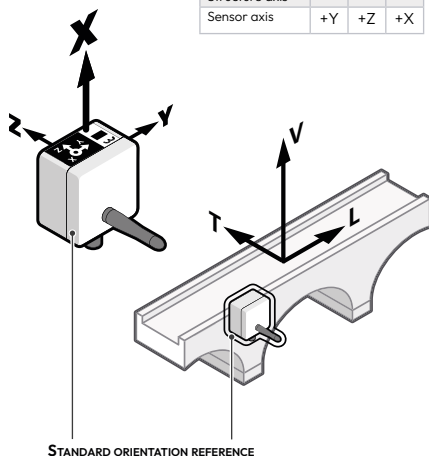

A.2

Structure axis	L	T	V
Sensor axis	+Z	-Y	+X

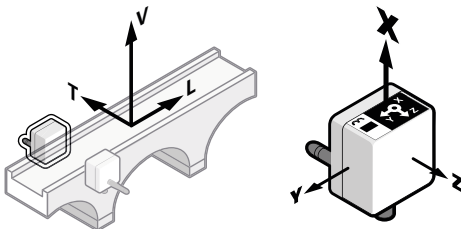

A.3

Structure axis	L	T	V
Sensor axis	-Y	-Z	+X

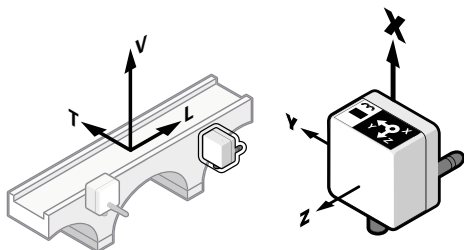

A.4.

Structure axis	L	T	V
Sensor axis	-Z	+Y	+X

B. X axis pointing downwards (-X as VERTICAL)



IMPORTANT

For optimal performance, **DO NOT** install the Accelerometer with the axis label facing downward and the connector pointing upward. The option to change the axis configuration in **MyMove** in the B.1, B.2, B.3 and B.4 orientations should be considered only as a failsafe measure, to be used exclusively when it is not possible to adjust the device orientation at the installation site.

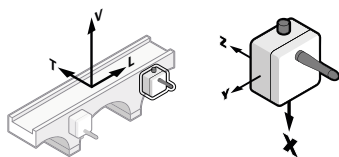

B.1

Structure axis	L	T	V
Sensor axis	-Y	+Z	-X

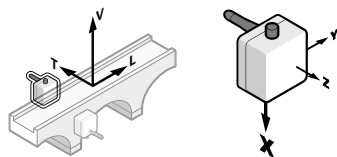

B.3

Structure axis	L	T	V
Sensor axis	+Y	-Z	-X

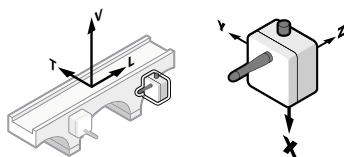

B.2

Structure axis	L	T	V
Sensor axis	+Z	+Y	-X

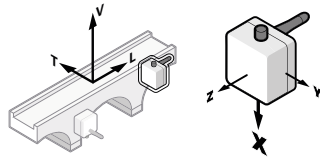

B.4

Structure axis	L	T	V
Sensor axis	-Z	-Y	-X

C. Y axis pointing upwards (+Y as VERTICAL)

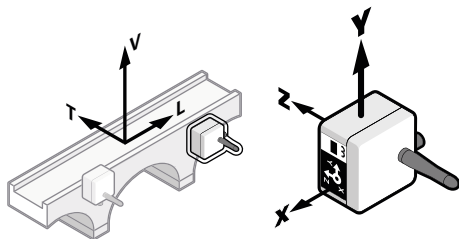

C.1

Structure axis	L	T	V
Sensor axis	-X	+Z	+Y

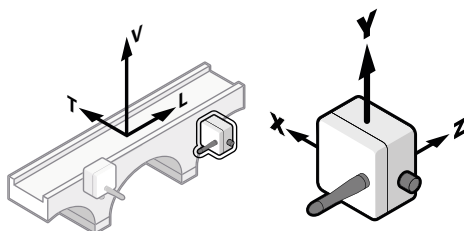

C.2

Structure axis	L	T	V
Sensor axis	+Z	+X	+Y

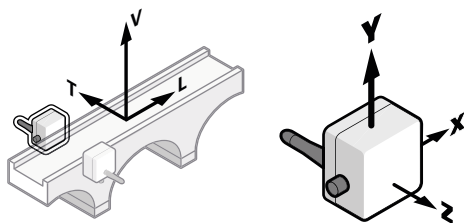

C.3

Structure axis	L	T	V
Sensor axis	+X	-Z	+Y

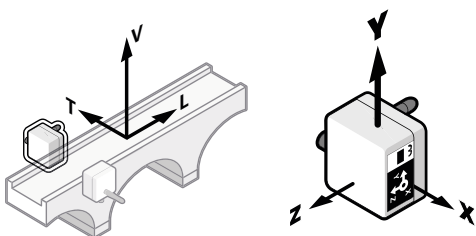

C.4

Structure axis	L	T	V
Sensor axis	-Z	-X	+Y

D. Y axis pointing downwards (-Y as VERTICAL)

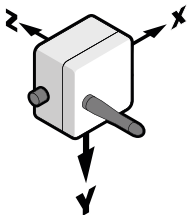
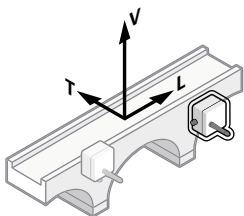

D.1

Structure axis	L	T	V
Sensor axis	+X	+Z	-Y

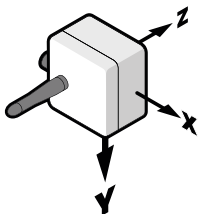
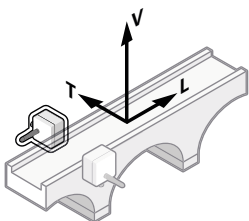

D.2

Structure axis	L	T	V
Sensor axis	+Z	-X	-Y

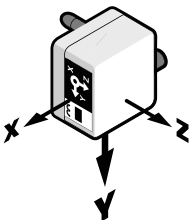
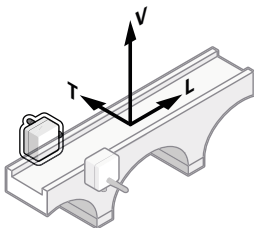

D.3

Structure axis	L	T	V
Sensor axis	-X	-Z	-Y

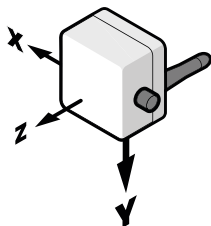
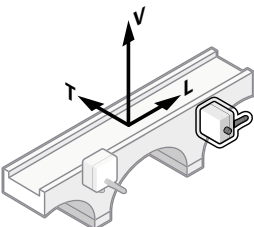

D.4

Structure axis	L	T	V
Sensor axis	-Z	+X	-Y

E. Z axis pointing upwards (+Z as VERTICAL)

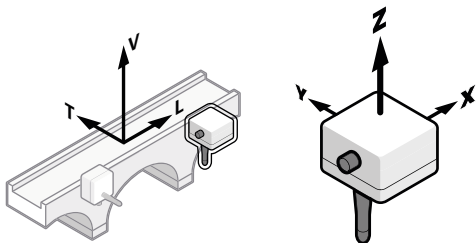

E.1

Structure axis	L	T	V
Sensor axis	+X	+Y	+Z

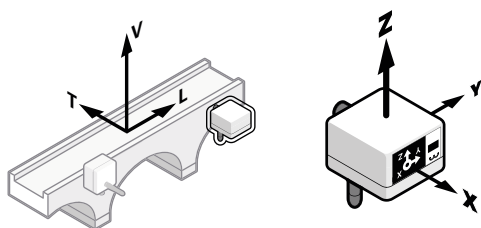

E.2

Structure axis	L	T	V
Sensor axis	+Y	-X	+Z

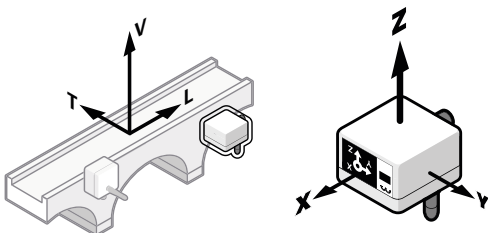

E.3

Structure axis	L	T	V
Sensor axis	-X	-Y	+Z

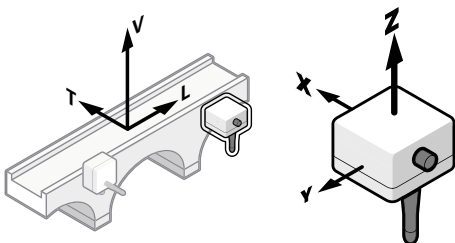

E.4

Structure axis	L	T	V
Sensor axis	-Y	+X	+Z

F. Z axis pointing downwards (-Z as VERTICAL)

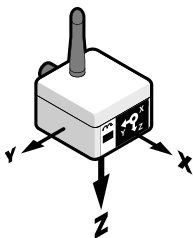
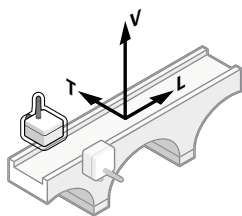

F.1

Structure axis	L	T	V
Sensor axis	-Y	-X	-Z

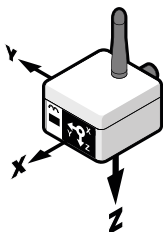
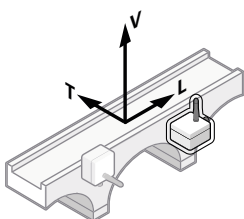

F.2

Structure axis	L	T	V
Sensor axis	-X	+Y	-Z

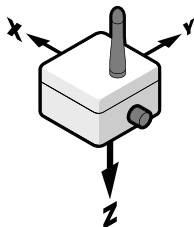
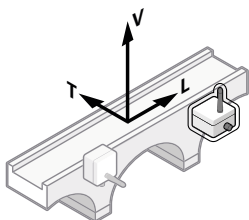

F.3

Structure axis	L	T	V
Sensor axis	+Y	+X	-Z

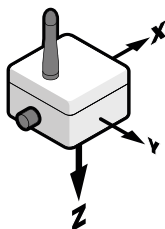
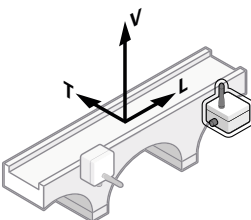

F.4

Structure axis	L	T	V
Sensor axis	+X	-Y	-Z

5.4 Optimizing radio performance

When installing the Accelerometer, it is important to follow some basic prescriptions to ensure the correct operation of the product.

Avoid, if possible, to locate the Gateway vertically above or under the Accelerometer. If this cannot be avoided, it is best to keep the two antennas perpendicular to one another. Keep the Accelerometer and the Gateway in line of sight as much as possible, as obstacles along the path of the signal could have a negative impact on the radio link.

Additional information on optimal positioning can be found on the Gateway manual.

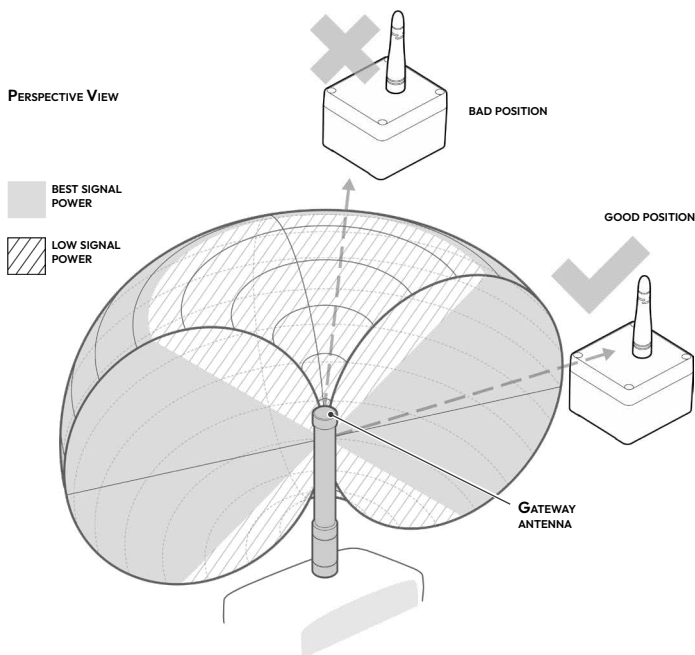

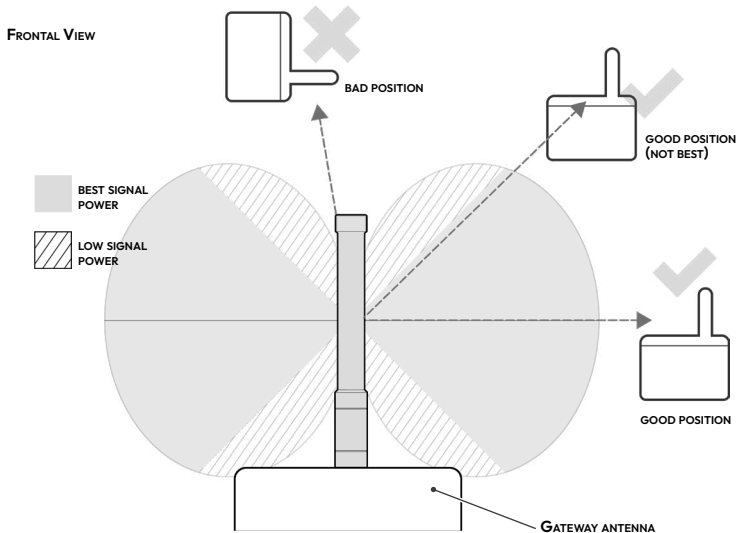

Try to keep the antenna as far as possible from metallic materials that could alter its radiative performance. Similarly, keep the antenna as far as possible of high voltage power cables, radio and tv antennas and any other source of unwanted electromagnetic disturbance.

Use the mounting hardware supplied with the Accelerometer to fix it to the wall, floor, or ceiling.



WARNING

Remember to install the Accelerometer away from busy areas where it could be damaged by or cause damage to animals or people.

For example, don't install the Accelerometer on the floor unless it's in a completely secluded area.

Installation



IMPORTANT

Installation must be performed by qualified personnel.

The mounting hardware provided and the instructions in this manual are for guidance only.

The choice of installation materials and the proper execution of the installation are the sole responsibility of the installer. Move Solutions is not responsible for any damages of any kind, including personal injury, resulting from the installation of the device.

Check that you have the right tools for the operation.

- A drill of suitable size
- An electric screwdriver of suitable size
- A level

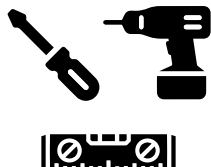

6.1 Standard mounting plate

The following procedure describes the standard wall-mount installation using anchors, with the sensor X-axis oriented upwards.

Alternative installation methods, such as adhesive mounting, are possible using appropriate tools and techniques specific to the selected mounting solution. These methods are not described in this manual.

If the sensor needs to be installed in a different orientation to match other sensors or system requirements, refer to Section [5.1 Axis Configuration](#).



IMPORTANT

Make sure the surface where the Accelerometer is going to be installed does not have asperities and protrusions. Close, stable and tight contact of the device with the surface is crucial to detecting accurate data.

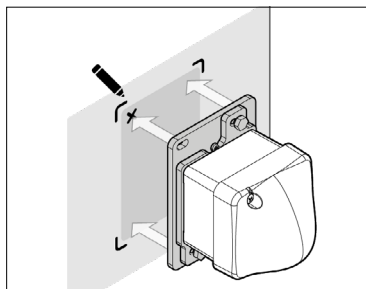

1. Using the installation plate as reference, mark the chosen spot.

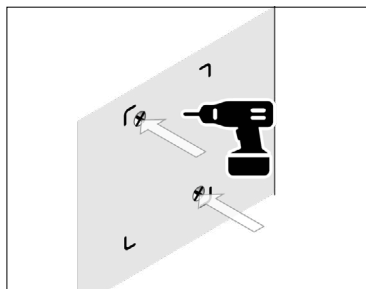

2. Drill two holes for the anchors in the mounting surface.

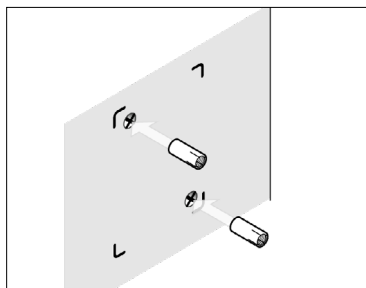

3. Insert the two anchors in the holes.

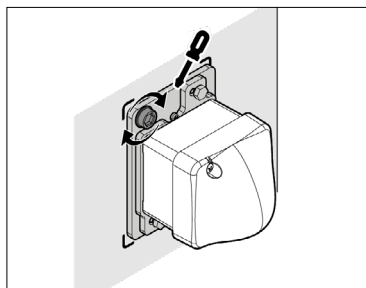

4. Place the Accelerometer on the structure and loosely tighten the two screws.

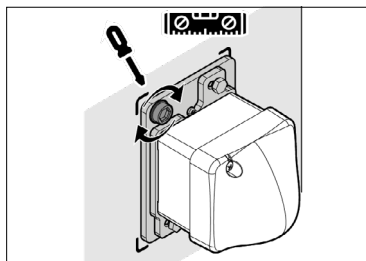

5. Using a level, make sure that the sensor is as horizontal as possible. The plate allows for slight corrections in inclination. Tighten the screws to lock in place.

If the Gateway is already running, you can start checking your data on **MyMove** platform within a few minutes. Otherwise, a maximum time of 30 minutes after the installation of the Gateway is required before the sensor can be viewed on the platform.

ADJUSTMENT VIA FIXED SCREWS

The two fixed screws allow for fine adjustment of the sensor's orientation after installation.

Loosen the screws to rotate the unit in either direction to correct its alignment or level it as needed.

Once the desired position is achieved, **fully tighten both screws** to secure the sensor firmly in place.

Ensure the screws are properly tightened to maintain stability and prevent unintended movement.

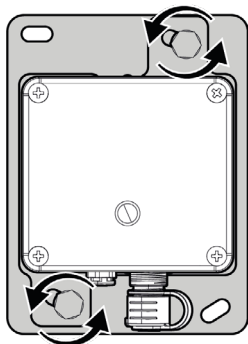

6.2 L-shaped mounting plate

The following procedure describes the standard wall-mount installation using anchors, with the sensor X-axis oriented upwards. The L-shaped mounting plate allows for additional mounting orientations depending on installation requirements.

Alternative installation methods, such as adhesive mounting, are possible using appropriate tools and techniques specific to the selected mounting solution. These methods are not described in this manual.

If the sensor needs to be installed in a different orientation to match other sensors or system requirements, refer to Section [5.1 Axis Configuration](#).



IMPORTANT

Make sure the surface where the Accelerometer is going to be installed does not have asperities and protrusions. Close, stable and tight contact of the device with the surface is crucial to detecting accurate data.

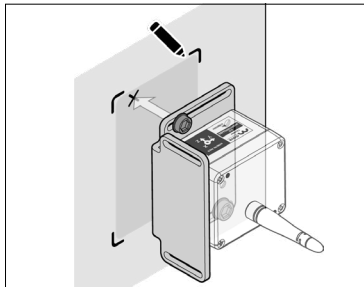

1. Using the installation plate as reference, mark the chosen spot.

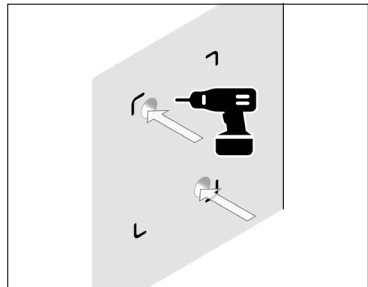

2. Drill two holes for the anchors in the mounting surface.

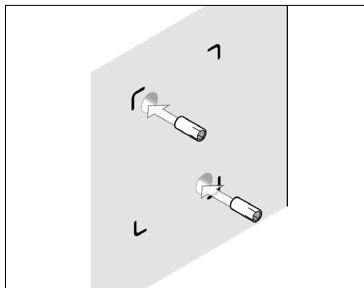

3. Insert the two anchors in the holes.

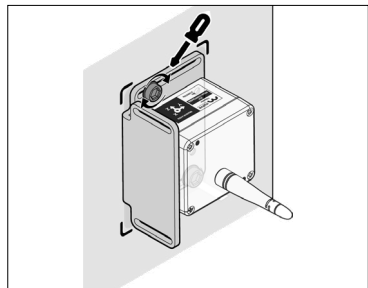

4. Place the Accelerometer on the structure and loosely tighten the two screws.

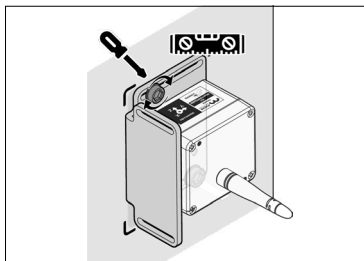

5. Using a level, make sure that the sensor is as horizontal as possible. The plate allows for slight corrections in inclination. Tighten the screws to lock in place.

If the Gateway is already running, you can start checking your data on **MyMove** platform within a few minutes. Otherwise, a maximum time of 30 minutes after the installation of the Gateway is required before the sensor can be viewed on the platform.

ANCHORS POSITIONING

Pay close attention to the positioning of the anchors on the plate: given the location of the serial connector, the ideal placement of the anchors is at the ends of the plate's holes and not in the middle.

For this reason, It is recommended that the anchors are positioned **opposite to each other** to ensure greater stability of the sensor, as shown in the figure.

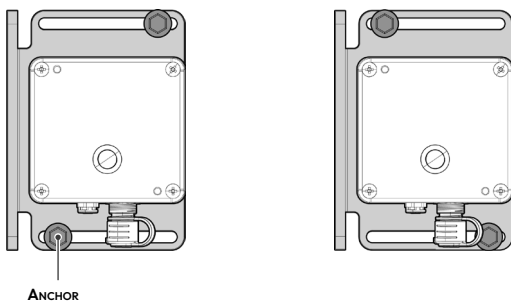

MyMove platform

7

GENERAL SETTINGS

To access MyMove, connect to the URL that you have been supplied with by Move Solutions and log in with your credentials.

Through the MyMove you'll be able to:

- check the data of the last 24 hours and the current state of all your devices
- explore all the data that has been gathered by your sensors since day one
- set alarms and email notifications for each sensor
- manage settings for each sensor
- ...and more!

NOTES

- MyMove is frequently updated with new features, fixes, and reviews. Refer to its documentation for more detailed information.
 - Settings that alter the Accelerometer behavior (settings that don't concern email alarms and sensor naming) can require up to 1 hour to be synchronized with the sensor.
-



Working principle

8

The accelerometer sensor supports three working modes, plus a combined one.

1. STANDARD TRIGGER

Threshold triggered, with waveform.

The sensor continuously acquires acceleration data and compares it with the selected Activation threshold. Once the threshold is exceeded, it acquires the event and sends both overall statistical (RMS and peak) and full waveform data to the MyMove platform.

NOTE

After the threshold is surpassed, the data buffer is filled with the configured number of samples. The first 8% of the data buffer depth is used to acquire pre-trigger samples (i.e. samples immediately before the trigger time), while the remaining part is for post-trigger samples.

This mode is suitable to detect asynchronous events where it is required to provide both overall statistical (RMS and peak) and full waveform data, which can be used for further processing, such as server-side FFT.

The waveform data transmission time (see related table for more details) introduces latency for the event availability on the MyMove platform.

2. FAST TRIGGER

Threshold triggered, without waveform, low latency.

The sensor continuously acquires acceleration data and compares it with the selected Activation threshold. Once the threshold is exceeded, it acquires the event and sends the overall statistical data (RMS and peak) to the MyMove platform.

NOTE

after the threshold is surpassed, the data buffer is filled with the configured number of samples. The first 8% of the data buffer depth is used to acquire pre-trigger samples (i.e. samples immediately before the trigger time), while the remaining part is for post-trigger samples.

This mode is suitable to detect asynchronous events where it is required to provide only overall statistical (RMS and peak). The waveform data is not acquired. This mode allows negligible latency in the data transmission to the MyMove platform.

3. PROGRAMMED

With synchronization among different sensors, for modal analysis.

The sensor starts sampling at fixed times throughout the day, depending on the cadence set for the sensor. Both overall statistical (RMS and peak) and full waveform data are sent to the MyMove platform.

Programmed acquisitions are performed with the selected cadence starting from the UTC midnight time.

In this mode, sensors that are part of the same application and share the same settings (cadence, sampling frequency, number of samples, etc.) will perform synchronized acquisitions with less than 500 μ s synchronization error between different sensors.

The waveform data transmission time (see related table for more details) introduces latency for the event availability on the MyMove platform.

4. PROGRAMMED + FAST TRIGGER

Combined mode, with priority for Programmed.

The sensor performs both Programmed and Fast Trigger acquisitions. Both modes work the same as described above, but in time-sharing with priority for the Programmed mode:

- When the sensor is acquiring data for a Programmed event, the Fast trigger mode is disabled.
- As soon as the sensor has done acquiring samples for a Programmed event, the Fast Trigger mode is re-enabled even if the Programmed event data transmission to the MyMove platform is not yet complete.

When this combined mode is selected the two modes are sharing the same radio connection bandwidth, so their respective performances are reduced compared to single-mode use cases. This means that transmission of waveform data requires more time, and the number of collected Fast Trigger events is reduced.



IMPORTANT

Opening the Accelerometer and breaking the seal voids the warranty. Only change the battery independently when the warranty has already expired. For issues on devices still covered by warranty, always consult Move Solutions before deciding to open the product.

Depending on the sensor's working settings and its environmental conditions, a battery change may be necessary every few months to every few years. In this event, only use the prescribed batteries.

For information on how to provision said batteries, please contact a Move Solutions representative. If the prescribed batteries are unavailable, or provisioning is not possible, consult a Move Solutions representative to find a viable alternative.



IMPORTANT

Move Solutions is not responsible for malfunctions and damage caused by batteries supplied by other companies and/or utilization of batteries different from the specified part number.

To change the battery:

1. Arrange the necessary tools to work safely where the Accelerometer is installed.
2. Make sure to work with dry hands and in a dry environment. It's advised not to change the batteries in humid, rainy, foggy, or snowy weather.
3. Open the lid. This voids the product's warranty (if still valid).
4. Disconnect the battery.
5. Insert the new battery.
6. Connect the new battery.
7. Properly close the lid tightening the screws. To tighten the screws, proceed in cross sequence and first tighten the screws gently, then tighten all screws to a torque of 1.7 Nm, still in cross sequence.

Overall dimensions

10

Please note that the drawings provided in this manual are not drawn to scale.

The purpose of these illustrations is to assist you in understanding the various components and their relative positions. Therefore, it is essential to rely on the numerical measurements provided alongside the drawings for accurate dimensions.

Standard mounting plate + standard antenna

The following measurements are expressed in millimeters (mm).

Side view

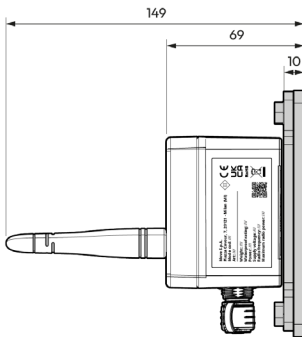

Front view

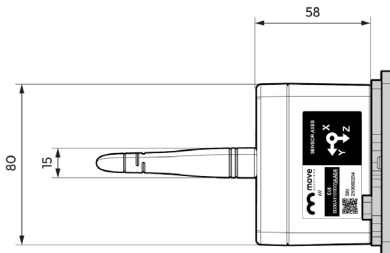
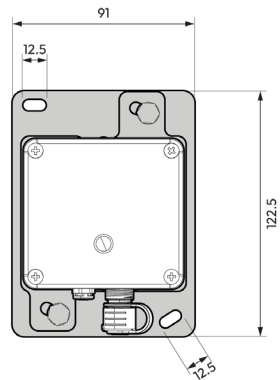

Top view

Standard mounting plate + short antenna

The following measurements are expressed in millimeters (mm).

Side view

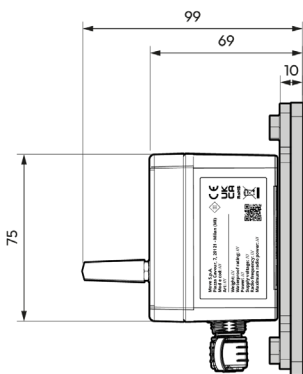

Front view

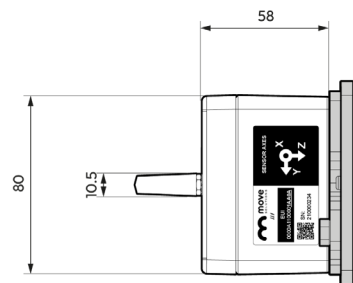
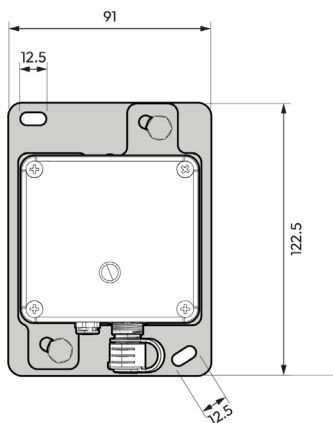

Top view

Standard mounting plate + short antenna + protective dome

The following measurements are expressed in millimeters (mm).

Side view

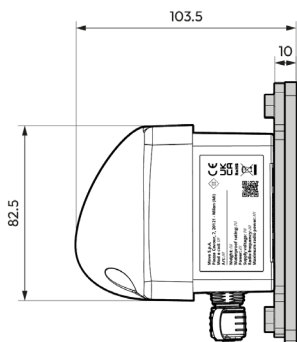

Front view

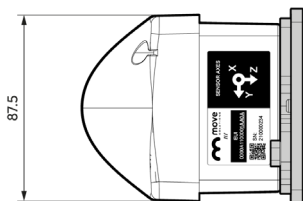
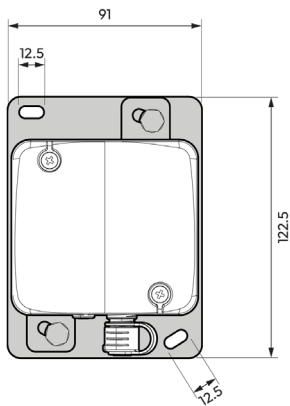

Top view

L-shaped mounting plate + standard antenna

The following measurements are expressed in millimeters (mm).

Side view

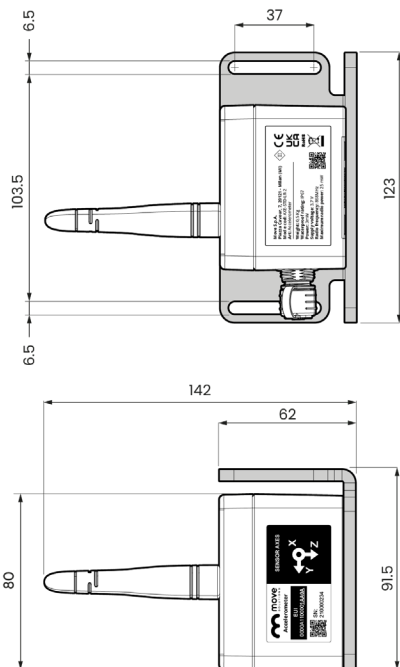

Front view

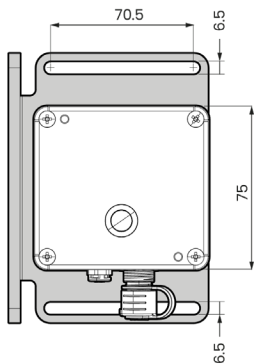

Top view

L-shaped mounting plate + short antenna + protective dome

The following measurements are expressed in millimeters (mm).

Side view

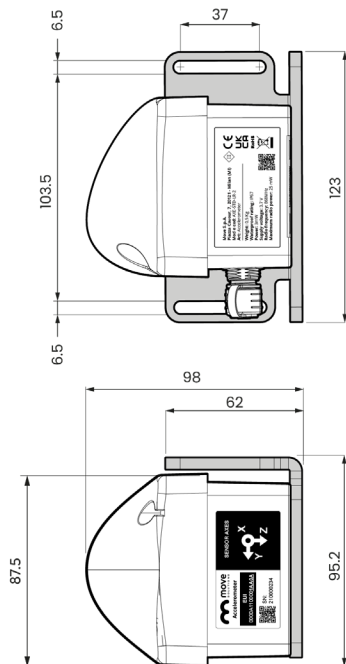

Front view

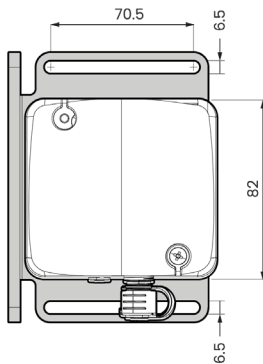

Top view

Annex A

Troubleshooting

Here we seek to give a few pointers to the most common misfunctions and suggested counter-measures.



WARNING

Remember to always disconnect the batteries before physically operating on the Accelerometer.

1. THE ACCELEROMETER IS OFFLINE

Check that a Gateway is installed nearby, and that it is online. If the Gateway is offline, refer to its manual or to the customer service to solve the problem. If the Gateway has no issues, the problem can be ascribed to the sensor itself, so follow these steps:

- Wait a few hours: the Accelerometer might be functioning correctly, but the data may not arrive due to high traffic on the radio channel. This might be the case in installations with a high density of LoRaWAN devices, or when the radio environment abruptly changed. The device automatically adapts its radio parameters to the environment, but in some cases up to one day might be required to reach stability.
- Examine the surroundings of the Accelerometer and check that no disturbance is present. Disturbances might come from industrial appliances, machinery, or metal objects in general. If the device has stopped working after regularly working for a while, investigate on environmental conditions that might have appeared (drastic changes in atmospheric conditions, such as fog or snow, or new obstacles that might have been installed). Changes in the device's environment could cause the device to go offline for several hours, for example if a large metal object is placed close to the sensor, behaving as a radio shield.
- Dismount the Accelerometer and move it in a location closer to the Gateway and wait up to one day. If the Accelerometer goes back online, it probably means that the radio path between it and the Gateway is suboptimal, and action needs to be taken.

If all these tests fail, refer to the customer support for assistance.

2. THE ACCELEROMETER IS ONLINE, BUT NO DATA IS SHOWING ON MYMOVE PLATFORM

The Accelerometer might be configured in Threshold triggering mode, but the measured data never reach the threshold. Check that the Accelerometer's mechanical coupling to the structure is correct. If the mechanical coupling is correct, then the measured data might actually be unable to reach the selected threshold: in this case, you can set a lower threshold to collect more data points. In case the instrument is using programmed acquisition based on a defined cadence, you can increase the cadence to collect more data points for the same time interval.

3. UNEXPECTED BEHAVIOR AFTER CHANGING THE SETTINGS

Changes made in the platform's setup menu might require up to 1 hour to be synchronized to the sensor. Moreover, if the setup is changed on more than one sensor, there might be a difference on when different sensors receive the new setting. For the best results, please allow some time for the system to stabilize after changing any settings.

Document revisions

N°	DATE	NOTES
Rev. 1	31 July 2025	Initial release
Rev. 2	23 February 2026	Text corrections and formatting updates
Rev. 3	2 April 2026	Complete template and style update

MOVE SOLUTIONS CUSTOMER ASSISTANCE SERVICE

Visit the website at www.movesolutions.it for contact information relating to office addresses and telephone numbers.

LICENSE AND COPYRIGHT

© 2026 Move S.p.A. All rights reserved.

PUBLICATION

Manual drafted in Italy

2 April, 2026

Revision 3

