

AXE-STD-LR-2, version 5.0











Accelerometer

The Accelerometer measures acceleration data expressed in “g” unit on the three orthogonal axes at the selected sample rate, and it can be synchronized with other Accelerometers for Modal Analysis.

Part of the Move Solutions sensor family, it integrates seamlessly with the MyMove platform.



KEY FEATURES

-  For indoor and outdoor operation
-  Long battery life, extendable with Battery Pack
-  Wireless LoRaWAN connection
-  Fully remote configuration and management
-  Quick, flexible, and easy installation
-  Measures acceleration (waveform and/or statistics) and temperature
-  Programmed data acquisition with high-accuracy synchronization between different sensors for Modal Analysis
-  Trigger-based data acquisition with selectable threshold
-  Data logging in the internal memory
-  Data management and processing through the MyMove platform

Its wireless design ensures quick and easy installation, significantly reducing time and costs.

The sensor is optimized for a very long operating life, which

can be further extended by adjusting the sensor configuration. To operate the sensor requires a Move Solutions Gateway installed nearby.

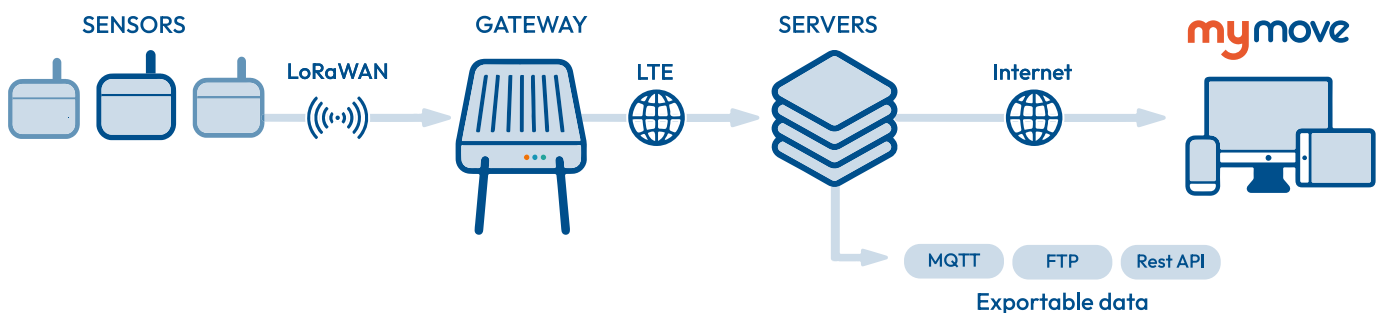

Output data

The sensor provides information about vibrational activity of the structure in which it is installed, by measuring the dynamic acceleration on the three axes. To do so acceleration data is high pass filtered to remove the continuous component due to gravity.

The input acceleration data is sampled over time and saved into the internal data buffer, whose depth is selectable by the user. The data collected is used to provide the RMS and peak values for the event. Moreover, for Standard trigger and Programmed modes, the sensor also provides the full waveform.

The sensor also records the temperature at measurement time.

Working principle

The Accelerometer sensor supports three working modes, plus a combined one.

1 STANDARD TRIGGER

Threshold triggered, with waveform.

The sensor continuously acquires acceleration data and compares it with the selected Activation threshold. Once the threshold is exceeded, it acquires the event and sends both overall statistical (RMS and peak) and full waveform data to the MyMove platform.

NOTE

After the threshold is surpassed, the data buffer is filled with the configured number of samples. The first 8% of the data buffer depth is used to acquire pre-trigger samples (i.e. samples immediately before the trigger time), while the remaining part is for post-trigger samples.

This mode is suitable to detect asynchronous events where it is required to provide both overall statistical (RMS and peak) and full waveform data, which can be used for further processing, such as server-side FFT.

The waveform data transmission time (see related table for more details) introduces latency for the event availability on the MyMove platform.

2 FAST TRIGGER

Threshold triggered, without waveform, low latency.

The sensor continuously acquires acceleration data and compares it with the selected Activation threshold. Once the threshold is exceeded, it acquires the event and sends the overall statistical data (RMS and peak) to the MyMove platform.

NOTE

After the threshold is surpassed, the data buffer is filled with the configured number of samples. The first 8% of the data buffer depth is used to acquire pre-trigger samples (i.e. samples immediately before the trigger time), while the remaining part is for post-trigger samples.

This mode is suitable to detect asynchronous events where it is required to provide only overall statistical (RMS and peak). The waveform data is not acquired. This mode allows negligible latency in the data transmission to the MyMove platform.

3 PROGRAMMED

with synchronization among different sensors, for modal analysis.

The sensor starts sampling at fixed times throughout the day, depending on the cadence set for the sensor. Both overall statistical (RMS and peak) and full waveform data are sent to the MyMove platform.

Programmed acquisitions are performed with the selected cadence starting from the UTC midnight time.

In this mode, sensors that are part of the same application and share the same settings (cadence, sampling frequency, number of samples, etc.) will perform synchronized acquisitions with less than 500 μ s synchronization error between different sensors.

The waveform data transmission time (see related table for more details) introduces latency for the event availability on the MyMove platform.

4 PROGRAMMED + FAST TRIGGER

combined mode, with priority for Programmed.

The sensor performs both Programmed and Fast Trigger acquisitions. Both modes work the same as described above, but in time-sharing with priority for the Programmed mode:

- When the sensor is acquiring data for a Programmed event, the Fast trigger mode is disabled.
- As soon as the sensor has done acquiring samples for a Programmed event, the Fast Trigger mode is re-enabled even if the Programmed event data transmission to the MyMove platform is not yet complete.

When this combined mode is selected the two modes are sharing the same radio connection bandwidth, so their respective performances are reduced compared to single-mode use cases. This means that transmission of waveform data requires more time, and the number of collected Fast Trigger events is reduced.

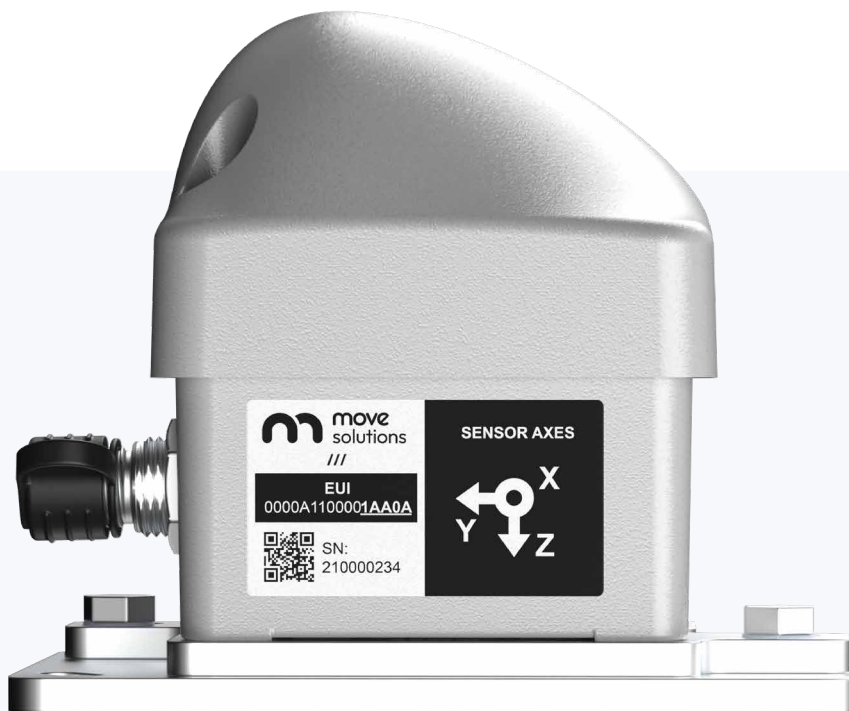

Technical specifications

MEASUREMENT PERFORMANCES

Sensing technology	MEMS accelerometer (3 axes)					
Noise density	22.5 $\mu\text{g}/\sqrt{\text{Hz}}$					
Sampling frequency and Bandwidth ¹	Sampling frequency	Low Bandwidth limit		High bandwidth limit		
	40 Hz	0.15 Hz		15.625 Hz		
	80 Hz	0.3 Hz		31.25 Hz		
	160 Hz	0.15 Hz		62.5 Hz		
	320 Hz	0.3 Hz		125 Hz		
	640 Hz	0.15 Hz		250 Hz		
Full scale range and resolution	Full scale range	Resolution				
	± 128 mg	3.90625 μg				
	± 256 mg	7.8125 μg				
	± 512 mg	15.625 μg				
	± 1.024 g	31.25 μg				
	± 2.048 g	62.5 μg				
	± 4.096 g	125 μg				
Data buffer depth ² Total / pre-trigger ³	Number of samples	Duration v/s Sampling Frequency				
		40 Hz	80Hz	160 Hz	320 Hz	640 Hz
	128 (11)	3.2/0.26 s	1.6/0.14 s	0.8/0.07 s	0.4/0.03 s	0.2/0.02 s
	256 (21)	6.4/0.51 s	3.2/0.26 s	1.6/0.13 s	0.8/0.07 s	0.4/0.03 s
	512 (41)	12.8/1.03 s	6.4/0.51 s	3.2/0.26 s	1.6/0.13 s	0.8/0.07 s
	1024 (82)	25.6/2.05 s	12.8/1.03 s	6.4/0.51 s	3.2/0.26 s	1.6 / 0.13 s
	2048 (164)	51.2/4.1 s	25.6/2.05 s	12.8/1.03 s	6.4/0.51 s	3.2/0.26 s
	4096 (328)	102.4/8.2 s	51.2/4.1 s	25.6/2.05 s	12.8/1.03 s	6.4/0.51 s
	8192 (656)	204.8/16.4 s	102.4/8.2 s	51.2/4.1 s	25.6/2.05 s	12.8/1.03 s
16384 (1311)	409.6/32.8 s	204.8/16.4 s	102.4/8.2 s	51.2/4.1 s	25.6/2.05 s	

¹ Down sampled from a main sampling frequency of 4 kHz.

² In case of Fast Trigger and Standard Trigger acquisitions includes both pre-trigger and post-trigger buffers.

³ Pre-trigger only applies to Fast Trigger and Standard Trigger modes.

MEASUREMENT PERFORMANCES

Operating modes	Programmed acquisition	
	Fast Trigger acquisition	
	Standard Trigger acquisition	
	Programmed acquisition + Fast Trigger ¹	
Cadence for programmed acquisitions	30 minutes	
	1 hour	
	2 hours	
	3 hours	
	4 hours	
	6 hours	
	8 hours	
	12 hours	
Timestamp accuracy ²	± 1 s	
Synchronization accuracy between sensors in Programmed mode		≤ 500 μs
Temperature resolution		0.05 °C
Temperature accuracy		0.2 °C
Internal storage memory ³ (circular)		Up to 60,000 events including waveform
		Up to 250,000 events not including waveform

¹ If more modes are enabled at the same time, their performance may be reduced. To achieve the best performances for each mode, please avoid using combined mode.

² Under good LoRaWAN radio coverage.

³ The actual memory capacity may vary depending on sensor configuration and input signal characteristics.

WAVEFORM DATA TRANSMISSION DURATION^{4,5,6}

128 samples	256 samples	512 samples	1024 samples	2048 samples	4096 samples	8192 samples	16384 samples
10 s	15 s	25 s	45 s	1 m 20 s	2 m 30 s	5 m	10 m

⁴ The estimation refers to a sensor in a typical working environment with good quality radio connection between the sensor and the Gateway. It also refers to an input signal (acceleration) whose value does not exceed 25% of full scale.

⁵ The estimation is valid for all sampling frequencies (40 Hz, 80 Hz, etc.).

⁶ The transmission duration is considered starting from the event start until the last packet is sent to the MyMove platform.

GENERAL DATA

Wireless connection technology	Sub-GHz LoRaWAN protocol ¹ (Gateway required)
Wireless coverage ²	1 km line of sight from the nearest Gateway
Connections	Move Solutions 8-pole connector. For compatible accessories visit Move Solutions' website or contact support.
IP rating ³	IP67
Power supply	1x 19Ah 3.6V replaceable lithium battery (D-type LiSOCl ₂ with JST EHR-2 connector, suggested EVE ER34615 EHR2)
Operating temperature range	From -40 °C to +85 °C
Dimensions ⁴	97.5 x 80.5 x 66 mm
Weight ⁴	0.5 kg
Package weight	0.8 kg
Case material	GD-ALSi12 alloy
Installation options	Wall, floor, or ceiling mount. Two-points attachment using screw anchors (Ø6mm max). One set included in the package.
Software version	v5

¹ The sensor's LoRaWAN connection operates on a best-effort basis, which means that while most data packets are delivered, there is a slight possibility of occasional packet loss.

² Wireless coverage may vary based on the actual deployment scenario.

³ The declared IP rating is guaranteed only when the product is correctly assembled, with the lid properly screwed in place, the antenna installed, and the Move Link connector protected either by a properly connected external cable or by the supplied protective cap when no cable is present.

⁴ Refers to the sensor unit itself. External accessories, such as mounting plate, antenna and protection cover for the antenna are not considered since they are optional and/or can be replaced with alternative parts to fit specific applications.

BATTERY LIFE

Configuration ^{1,2}	Internal battery	Battery Pack (combined) ³
Programmed acquisition with 30 minutes period Data buffer depth: 4096, Sampling Frequency: 80 Hz	1 year	3 years and 3 months
Programmed acquisition with 1 hour period Data buffer depth: 4096, Sampling Frequency: 80 Hz	2 years	5 years and 9 months
Programmed acquisition with 6 hours period Data buffer depth: 4096, Sampling Frequency: 80 Hz	8 years	13 years and 5 months
Standard Trigger acquisitions ⁴ (including waveform), 5 events/hour Data buffer depth: 1024, Sampling Frequency: 80 Hz	1 year	3 years and 3 months
Fast Trigger acquisitions ⁴ (without waveform), 5 events/hour Data buffer depth: 1024, Sampling Frequency: 80 Hz	4 years	9 years and 3 months

¹ Configuration parameters that are not specified are to be considered in their default configuration.

² The estimation refers to a sensor in a typical working environment with average quality of the radio connection between the sensor and the Gateway. Actual battery life may be worse in case the product is used under extreme conditions, such as prolonged working in high or low temperatures, bad quality of radio connection between the sensor and the Gateway, etc.

³ Battery Pack sold separately.

⁴ The consumption of trigger acquisitions depends on the actual input signal of the sensor and its configuration, so it may differ from the stated.

ORDERING INFORMATION

SENSOR	PART NUMBER
Accelerometer sensor, standard <i>Includes: sensor unit, standard antenna, standard mounting plate</i>	AXE-STD-LR-2
ACCESSORIES	PART NUMBER
Short antenna + protective dome	ANT-DME-MB-0
Short antenna	ANT_SHORT
Battery Pack	SBE-STD-CB-1
Data download cable	SCM-STD-CU-1
L-shaped mounting plate	ATM-INOXL-FP

Mechanical drawings

STANDARD MOUNTING PLATE + STANDARD ANTENNA

All dimensions are in millimeters

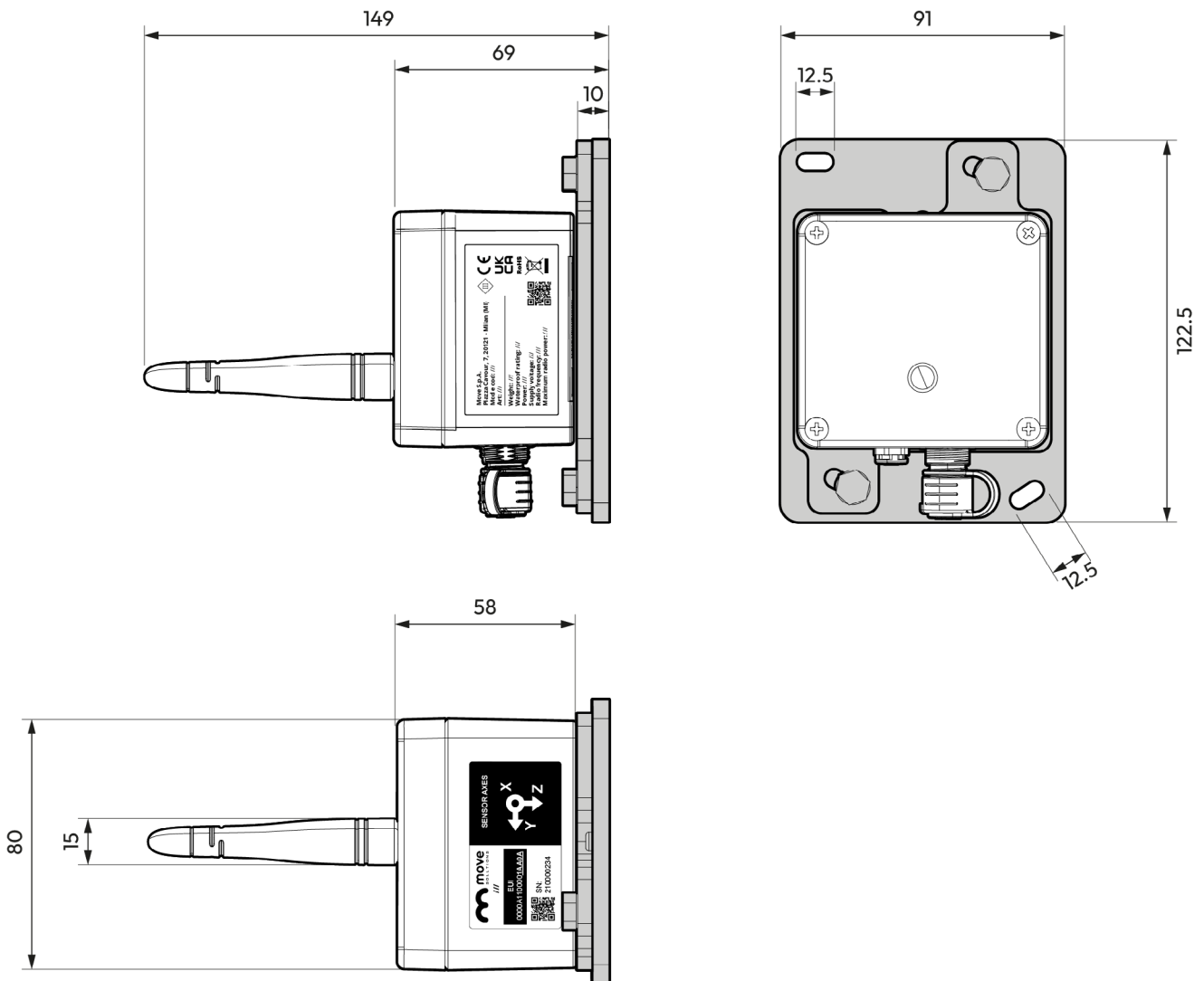

STANDARD MOUNTING PLATE + SHORT ANTENNA

All dimensions are in millimeters

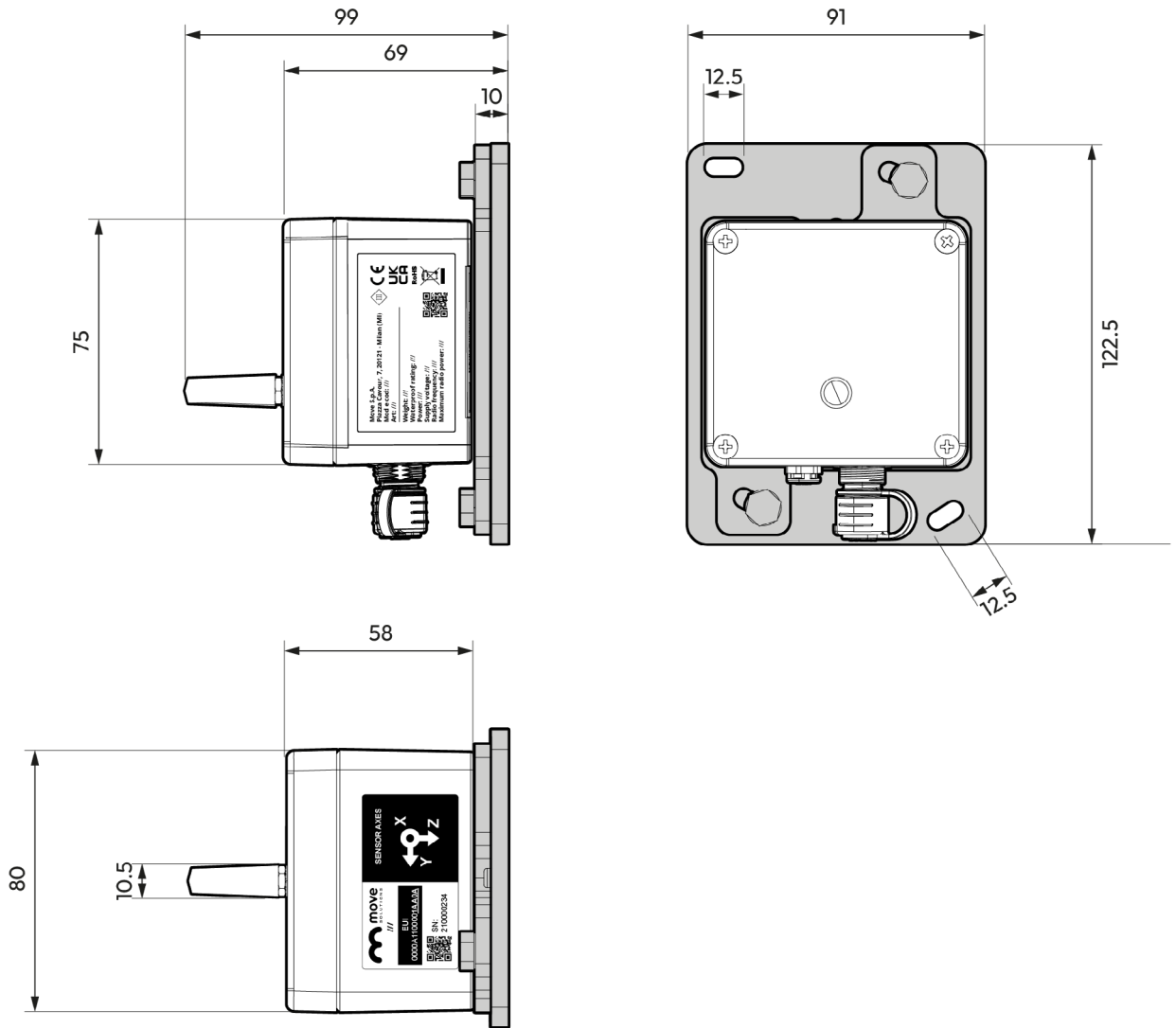

STANDARD MOUNTING PLATE + SHORT ANTENNA + PROTECTIVE DOME

All dimensions are in millimeters

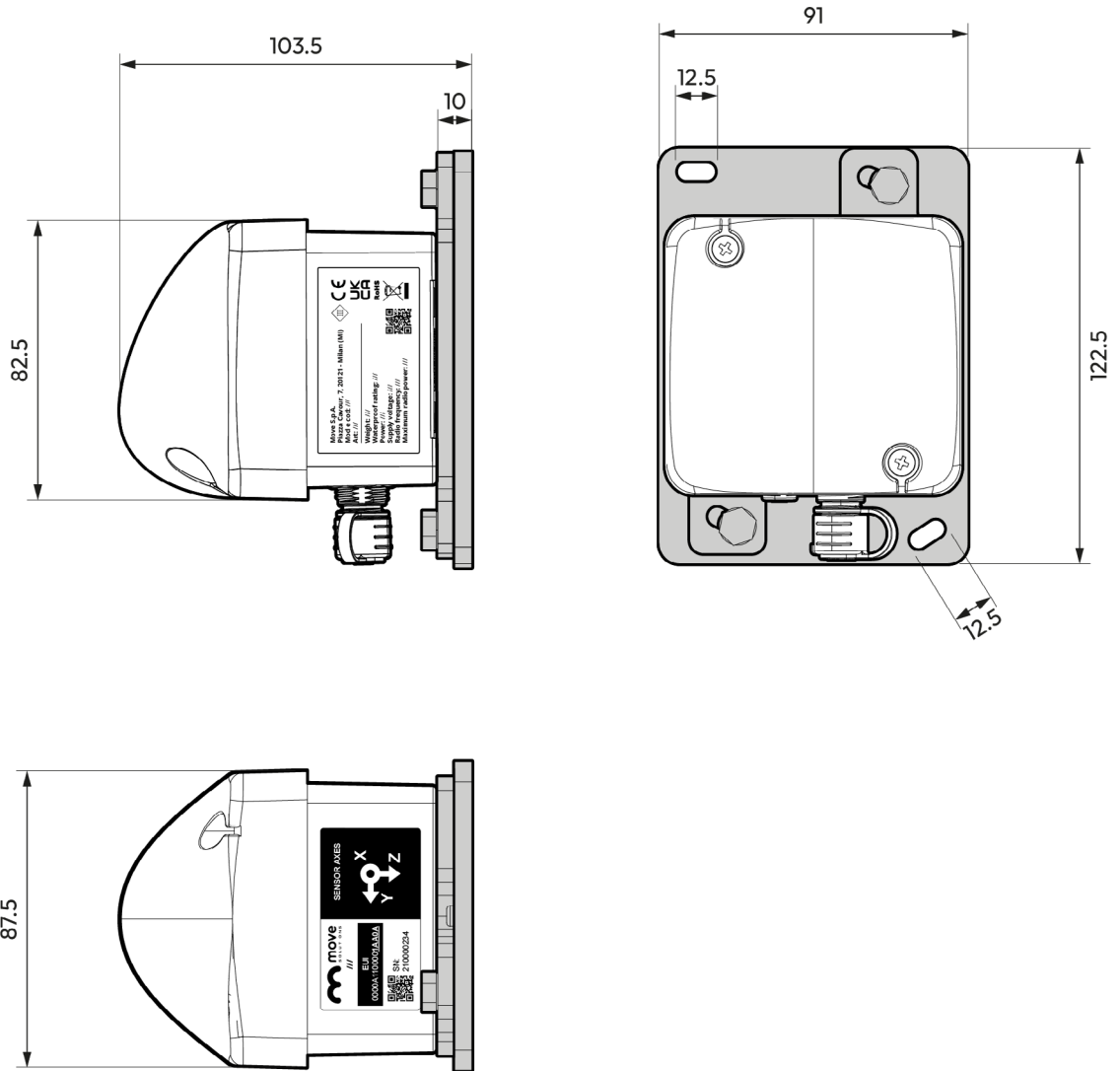

L-SHAPED MOUNTING PLATE + SHORT ANTENNA

All dimensions are in millimeters

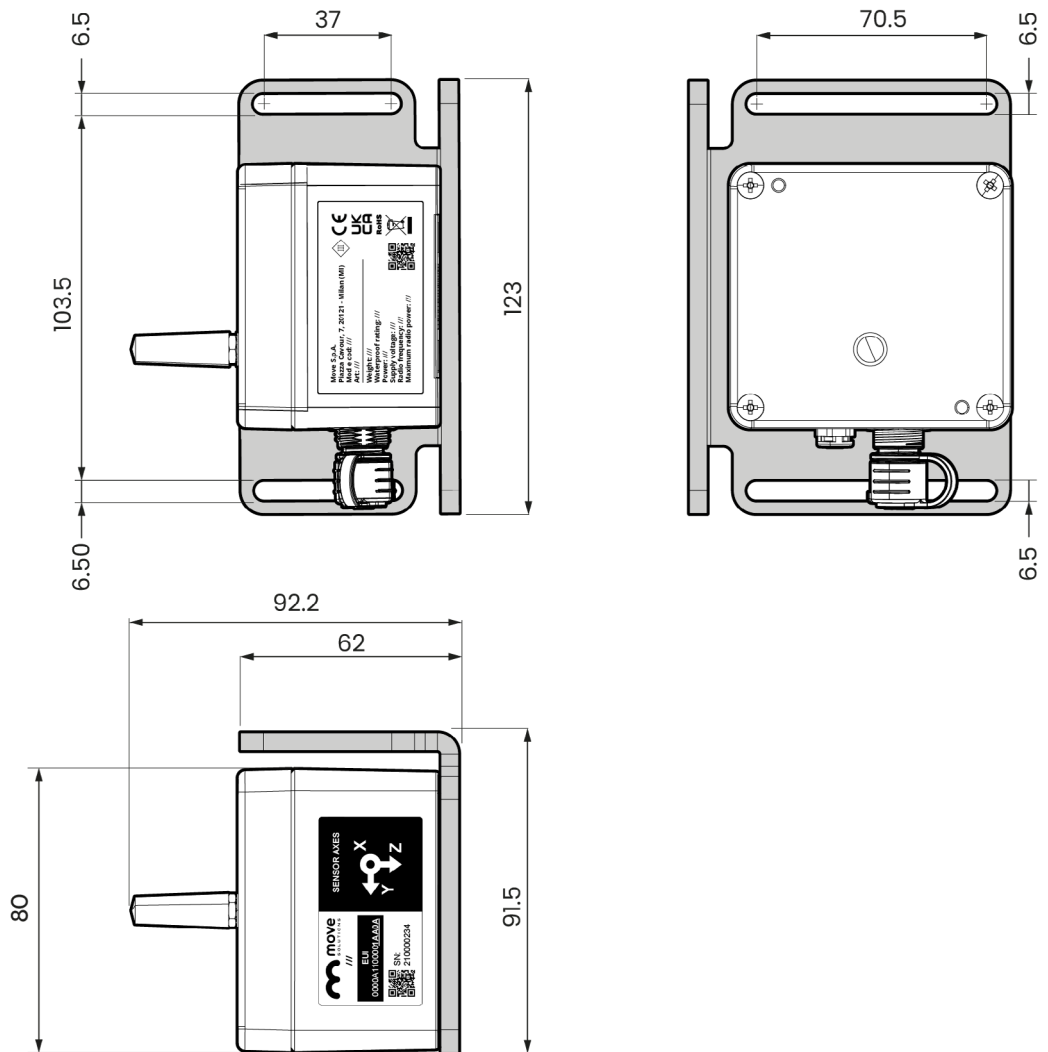

L-SHAPED MOUNTING PLATE + SHORT ANTENNA + PROTECTIVE DOME

All dimensions are in millimeters

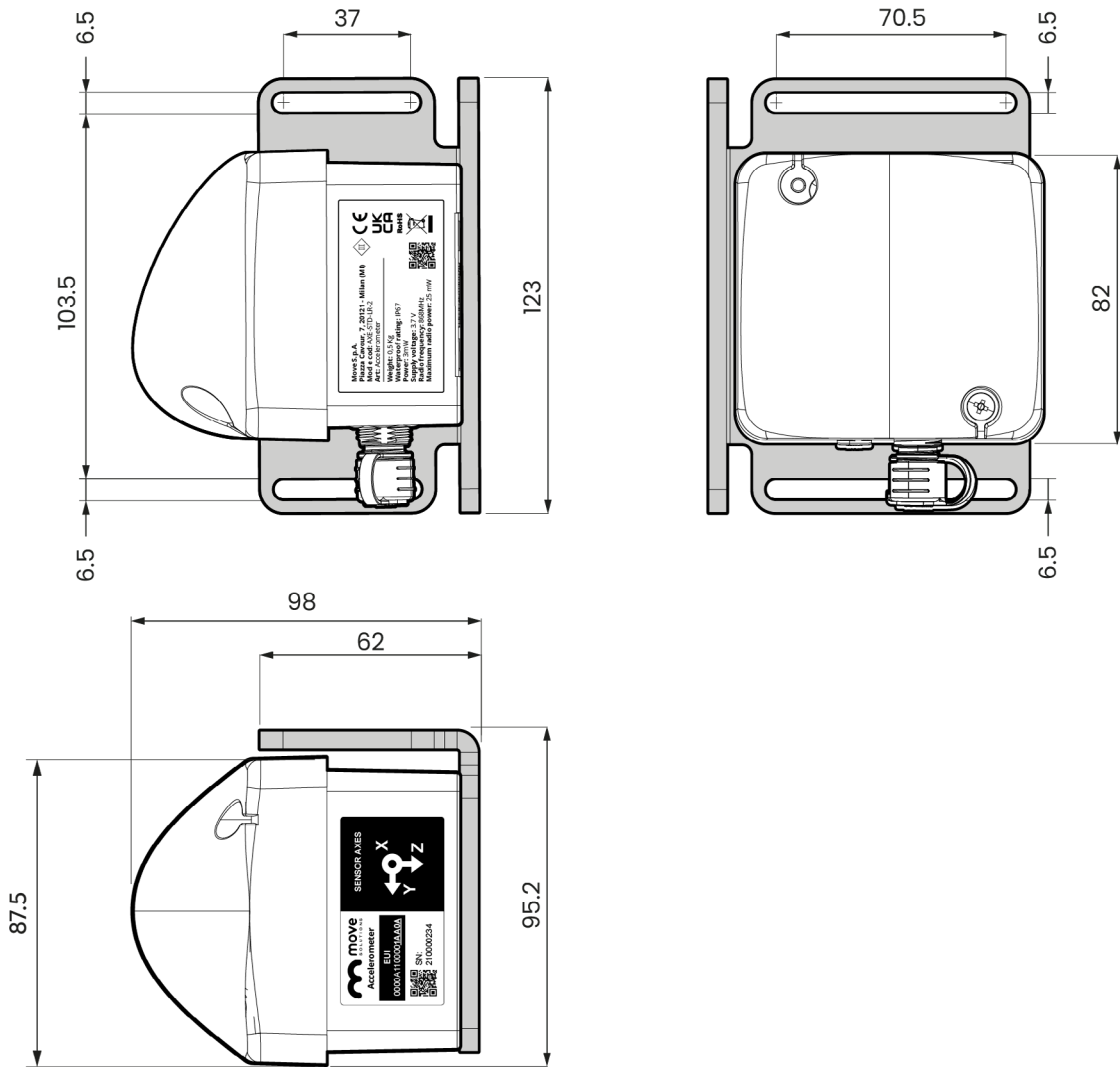

For complete information regarding proper use of the device, safety precautions, installation, operation, and maintenance requirements, users must refer to the official product manual.

DOCUMENT REVISIONS

N°	DATE	NOTES
REV 1	5 November 2025	Initial release
REV 2	30 March 2026	Complete template and style update

Notice of publication

The information contained in this document may be subject to change without notification. For more detailed information, product specifications and to download up-to-date documents, visit our website at www.movesolutions.it.