

Clinical Tools

A DIY catalogue for the creative

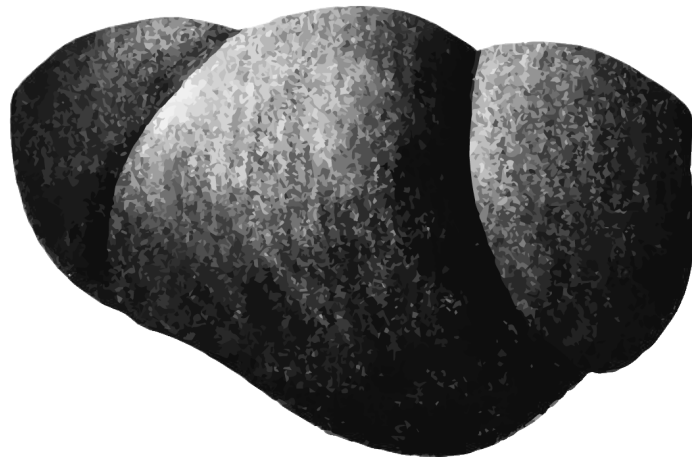

01

INTRODUCTION A DIY CATALOGUE FOR THE CREATIVE

02

02

SKILLS DIYS TO HELP YOU PRACTICE

02

Eye Models	02
The Papaya - Coconut Model	02
The Placenta Model	03
Suturing on Fruit	04
Suture Pad Station	06
Simulator for Flexor Tendon Repairs	08
Simulated Membranes	10
Vaginal Examination with Oranges and Socks	11
Ultrasound Phantom for Simulation Training in Abscess Identification and Aspiration	12
3D Printed Thoracic Epidural Model	14

03

ANATOMY DIYS TO HELP YOU SEE

02

Painted Wounds	02
Knitted Uterus	02
Female Reproductive System Model	03
Second Skin Fidelity Model	04
Eye Model	06
Clay Heart Model	08
Tooth Model	10
Digestive System Model	11

Lungs Model	12
Cranial Nerve Model	14
Knee Model	16

04

ESSAYS A NEW WAY OF TEACHING IN MEDICAL EDUCATION

02

Advantages of making DIYs	20
Differences between the Mannequins and the DIY models	21
Challenges of Making in Medical Education	22
Need for a Network of Medical DIYers	23
Medical Education and (Post) Colonialism	25
Inclusivity of Bodies	26

05

OUTRO THOUGHTS AND REFLECTIONS

02

Conclusion	20
Insights from an Illustration Student	21
Contributors and Acknowledgments	22
Interesting Resources	23
Cut-outs	24

INTRODUCTION

A DIY

CATALOGUE FOR

THE CREATIVE

[Introduction]

Instead of encouraging the purchasing of new technologies for medical training, this catalogue tries to set an example of finding and sharing creative tools that already exist in medical education. Furthermore, it shows how to make use of local resources, meaning that the tools are not only practical and educational but also inexpensive and sustainable.

In education, as in most domains of society, there is a relentless obsession with “the new”. Across educational programs, there is a focus on technological innovation such as virtual reality, augmented reality and digital learning tools, all influenced by the boom in EdTech, which was accelerated by the COVID-19 pandemic. In the social sciences and humanities, however, there is a growing shift away from the pursuit of innovation towards a study of practices of repair and maintenance (Vinsel & Russell, 2020). This involves looking after existing materials as well as making-do with what is already on hand. Many different fields use ready-made materials in teaching, whether it be making models in architecture or mathematics, or crafting instruments for scientific experimentation. This catalogue focuses on educational tools and the potential for DIY (do-it-yourself) for universities and other settings.

In the skills training part of most health professions educational (HPE) settings, examples of DIY practices can be found, such as homemade body parts for practising stitching, or models for learning anatomy, but they have rarely been studied, nor shared outside of the local context.

To help address this problem and fill the gap, this catalogue brings together examples from education of healthcare professionals, rethinking the current focus on digital innovation and high fidelity, something which we believe that many different disciplines could benefit from. This catalogue explicitly highlights existing practices, techniques and examples of handmade, DIYs, and repurposed teaching tools that have been made by educators in Maastricht (the Netherlands), and around the world including in Kenya, Vietnam, South Africa, Hungary, South Korea, Sierra Leone, the United Kingdom and the United States. One of the goals of this catalogue is to learn more about these practices and explore ways that DIYs might be better shared.

Our previous research has already shown that DIY learning tools have numerous advantages. First, they allow for more locally relevant teaching materials, as by making models themselves, educators can make sure to reproduce the specific diseases that students are likely to find in their communities. In the same vein, this approach also allows for better diversity of models, stretching beyond the current dominance of the white and often male body in learning materials. Second, making DIY materials also addresses issues of sustainability, which are seldom discussed in the context

of skills education. Currently, the majority of research on this issue addresses how doctors can educate patients or be involved in climate crisis efforts (e.g. Katzman et al., 2023) but neglects their own learning environments. DIY involves cutting down on the use of plastics, which became abundant in the use of skills training models after World War II. Instead, it can favour either vegan, organic or repurposed materials.

This catalogue is based on an extensive review of publications and online databases of medical DIYs, interviews with medical educators and makers, and asking medical students to make two of the DIYs presented and write reviews.

The first section of the catalogue showcases 9 DIY models to help students practice their medical skills (from different fields) while the second section showcases 12 DIY anatomical models. The catalogue includes short essays about the advantages and challenges of making in medical education, differences between models, a rethinking and reflecting on the postcolonial dynamics present in medical education and the absence of representation of all bodies in high-fidelity mannequins.

- *Anna Harris, Emmaline Brouwer, Marijke Kruitbof, Giuliana Brancaleone and Nyah Costa*

FURTHER READING AND REFERENCES

Katzman, J. G., Balbus, J., Herring, D., Bole, A., Butke, D., & Schramm, P. (2023). Clinician education on climate change and health: virtual learning community models. The Lancet Planetary Health, 7(6), e444-e446.

Vinsel, L., & Russell, A. L. (2020). The innovation delusion: How our obsession with the new has disrupted the work that matters most. Crown Currency

SKILLS — DIYS TO HELP YOU PRACTICE



[Sensory Skills]

This first section will help you practice and strengthen the skills needed as a medical practitioner: how to listen, how to see, how to feel. Whether you are a teacher, learner, or just a curious soul, these objects will make you think outside of the box. Make these DIYS and practice your sensory skills at home, or in the classroom, without any limits on practicing hours.

EYE MODELS

Field: Ophthalmology

The commercial eye model was around 400 euros. When you purchase it, it comes with a complete set with many different eye retina diseases in a small slide format. When you put one of those slides behind the eye, you use an ophthalmoscope to look into it, and you see the whole retina the way you see it in a book. But the reality is that the eye is round, and so you need a fine hand and eye coordination skill when looking into the eye to see all of its different parts. The commercial model did not push students to develop

that skill. An alternative DIY model we made in Indonesia was with ping pong balls that were painted in the back, which allowed students to practice looking at the retina to find the blood vessels, arteries leading to the optic disc and the different quadrants of the eye. In reality, to find any signs of diabetes or hypertension, you need to follow the arteries around. So, with the commercial model, the students just had to look straight in and saw the whole picture at once, but with the DIY model, students could practice how to manoeuvre their head and hands with the ophthalmoscope to go

through all the different parts of the eye that they needed to check. So, the commercial model seemed to be teaching what students needed to learn according to the textbook, but when they have to examine a real patient, they will have no clue of what they will be actually looking for." Marijke Kruithof, on the 19th of March 2025.

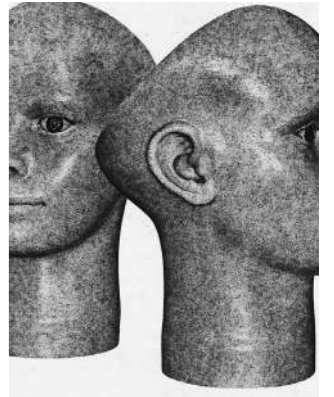

[Commercial Eye Model]

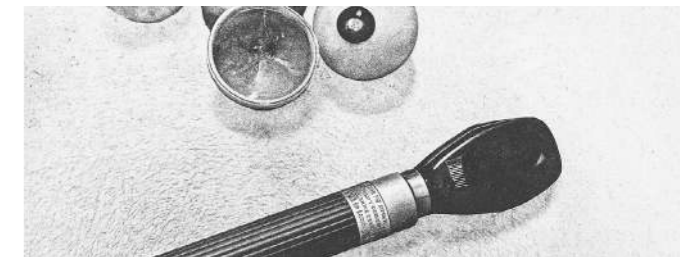

[DIY Model with ping pong balls]

These pictures show a much cruder, but equally effective model that was developed by Dr. Dason Evans, an ophthalmologist in the United Kingdom.

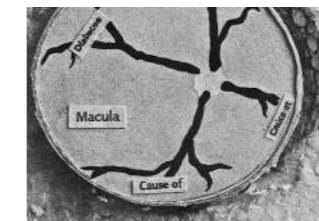

[Eye Models]

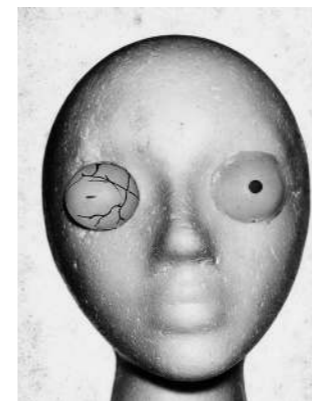

■ Photographs by Dr. Dason Evans, shared by Marijke Kruithof.



"Similarly, there is an ear model on which you can see all the different eardrums with different diseases, all at once. Again, when doing an examination with an otoscope in somebody's ear, you have to be very gentle in manoeuvring around for it not to be painful for the patient. In this case, the commercial models are not ideal, and letting the students practice with each other is more effective and cheaper overall." Marijke Kruithof, on the 19th of March 2025.

"You do need the very simple do-it-yourself models that any teacher can make, with simple materials and clear instructions. And if you have a good guideline for the teacher on how to produce a certain model, that is helpful."

MARIJKE KRUIHOF
on the 19th of March 2025.

THE PAPAYA - COCONUT MODEL

Field: *Obstetrics*

“After my GP training and my tropical medicine training, I worked in Sri Lanka and Ecuador for ten years. And that’s actually where I first started thinking about the use of DIYs in medicine, because when I had been working in The Netherlands I was used to all the nice models that we had in the skills lab, and there we didn’t have access to the same models. So I started thinking about how we could do things

in a different way. My very first model was actually a way to practice doing pregnancy exams in midwifery training: I used a papaya and a coconut from the market, which I wrapped in a piece of fabric, and positioned on one of the midwives’ bellies with her dress over it. With the coconut, we could simulate a three month pregnancy, and with the papaya, it represented a five month pregnancy. The combination of both the coconut and the papaya can simulate a normal head or a breech position of the baby.”

MARIJKE KRUIHOF
on the 19th of March 2025.

The 3rd picture displaying the combination of the coconut and the papaya demonstrates a breech position:



[The Papaya Coconut Model]



THE PLACENTA MODEL

Field: *Obstetrics*

“The second next model I made was a representation of the placenta, used to show the midwives what they needed to check when the placenta came out after delivery. It also helped them understand that the placenta is attached to the uterus wall in one way, but then when it gets pulled out it flips on itself, so it is covered by the membranes which were around the child. The midwives needed to learn how to open up the membranes to see if the placenta was complete. One of the most common causes of maternal death is either bleeding due to parts of the placenta left behind, or being torn off, or if parts of the placenta stay behind and get infected. So practicing this verification skill is crucial in midwifery

training. This model was made with materials I found locally: some flannel fabric, a few plastic bags, and red and blue sewing thread. At the School of Midwifery Masuba, Makeni, in Sierra Leone, the students have also played with textures on the placenta model, missing elements, or the addition of the umbilical cord. That puts the students in different situations and allows them to visualize the placenta in different ways”.

MARIJKE KRUIHOF
on the 19th of March 2025.

Marijke Kruithof’s own placenta model:

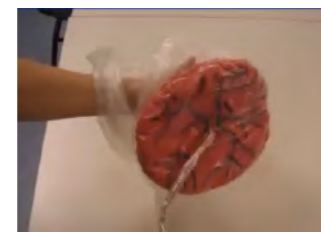

that the students produced during a workshop with Marijke Kruithof, in January 2012, at the School of Midwifery Masuba, Makeni, in Sierra Leone.



[Placenta Model]

■ Photographs by Marijke Kruithof.

When Marijke Kruithof returned to the School of Midwifery Masuba, Makeni, in Sierra Leone, Cecilia Lansana

and herself embroidered half of a placenta model with small knots of white threads. This made the placenta model look and feel like a placenta with microcalcifications.



■ Photographs by Marijke Kruithof.

After that, the students became really creative in making their own placenta models with all kinds of abnormalities. These models were the results presented to Marijke Kruithof in December 2012 (at the School of Midwifery Masuba, Makeni, in Sierra Leone).

COMMUNICATION SKILLS THROUGH ROLE PLAY

Field: *Medicine*

Some skills, like communication, cannot be effectively practiced using mannequins (or DIY’s). “There are skills like communication skills... we use simulated patients,” Elizabeth Luchacha says. In these cases, students take turns playing the patient and healthcare provider roles.

This allows them to practice communicating properly in different medical scenarios without expensive equipment. For example, during exercises like hip checking or other physical assessments, they simulate the process using each other (and their bodies). “We don’t buy things, we just use ourselves,” Elizabeth explains, pointing out that many items in the skills lab are expensive, so they often rely on peer simulation to reduce costs. She also mentions

that while mannequins help practice certain procedures, such as resuscitation (PLS) on infants, adolescents, or older adults, they do not fully replace human interaction. By practising with each other, students not only improve their communication but also learn to adapt their approach depending on the patient’s age and condition”

ELIZABETH LAUCHACHA
on the 13th of March 2025.



SUTURING ON FRUIT

Field: *Surgery*

Banana peel is actually very similar to the human skin in texture, and so it is a great (and cheaper) way to practice simple suturing techniques. Grape is also a great fruit to simulate thinner and more fragile skin that is more delicate in certain areas of the body (like the face).

Pro-tip from students 1: Don’t wait too long to suture the banana or the peel will ripen and become brown!

Pro-tip from students 2: As the grape skin tears and rips easily, take your time and go slowly.

MATERIALS NEEDED:

- 1 banana and/or a few grapes
- Scalpel (or any sharp knife)
- Dissection scissors (or nail scissors)
- Surgical needle (or sewing

- needle)
- Surgical thread (or sewing thread)

Costs: under 2 EUR
Time: 10 minutes

INSTRUCTIONS

- For the banana peel
 - Use your scalpel (or knife) to slice the banana peel to simulate a deep cut.
 - Use the surgical needle and surgical thread (or equivalent materials) to sew the skin back together.
 - Demonstrate your best suturing skills!

- For the grapes:
 - Use your surgical scissors and make an incision into the skin of the grape (without piercing the soft flesh beneath it, be soft!).
 - Carefully sew it back together with the surgical needle and thread. This allows you to practice delicate stitching.
 -

THESE INSTRUCTIONS HAVE BEEN WRITTEN BASED ON THE FOLLOWING ACADEMIC ARTICLES:

“How to practice surgery skills on fruit” (July 2, 2022). <https://www.wikibow.com/Practice-Surgery-Skills-on-Fruit>

Liu, Y., Cui, N. H., Ge, W. S., Xie, S., An, N., He, X. Y., ... & Wang, D. C. (2023). The application of an intraoral banana peel suturing model in surgical training of dental students. *Journal of Dental Education*, 87(9), 1315-1320.

Wong, K., Bhama, P. K., Mazimpaka, J. D. A., Dusabimana, R., Lee, L. N., & Shaye, D. A. (2018). Banana fruit: an “appealing” alternative for practicing suture techniques in resource-limited settings. *American journal of otolaryngology*, 39(5), 582-584.

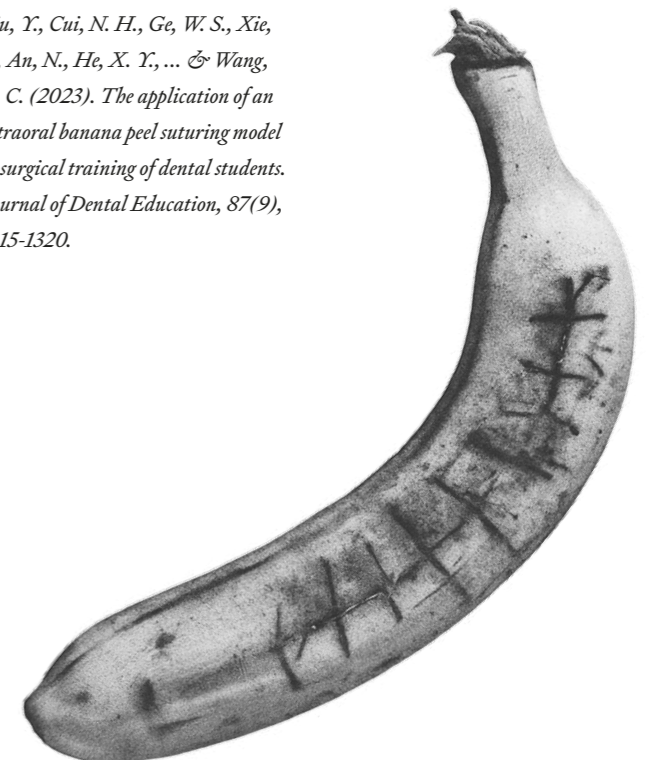

WHAT DO THE STUDENTS THINK OF THIS MODEL?



“I have had surgical classes but never sutured a fruit. I must say, the banana peel was quite similar to the feeling of suturing on fake skin models, but if you took too long the banana turned brown. This model is very relevant, as you can practice your suturing skills well with accessible materials (if you have suturing materials at home).”

“With this model. I learned how simple it is to practice medicine at home. I had not performed a surgical suture before, but this DIY was very accessible. It would have been helpful to practice it on a variety of fruit so that I can further practice patient diversity.”

Photograph and text by Lara Heindrichs, medical student at Maastricht University, (the Netherlands).

Photograph and text by a medical student at Maastricht University, (the Netherlands).

INSIGHTS FROM ELIZABETH LUCHACHA, TRAINED NURSE AND SKILLSLAB MANAGER AT THE NORTH COAST MEDICAL TRAINING COLLEGE IN KILIFI, KENYA:

Elizabeth appreciated the idea of using bananas as a DIY practice model. Recognizing that students often struggled to grasp suturing techniques through demonstration

alone, Luchacha created something more hands-on, based on the materials that were available to her in Kenya: To make it happen, she spoke with a colleague who managed supplies and asked if they could repurpose some available materials. After testing the idea and seeing it worked, she ordered the materials and started building the models.

“I found that most of the students when you teach them about suturing and you just show them, they don’t get it well, so they need more practice. I’m happy that you have told me to use bananas for practicing suturing. In my case I implemented something like that but I used wood and a canvas with thick sponges, and I made small boxes on which students can practice their suturing skills.”

ELIZABETH LUCHACHA on the 13th of March 2025.

SUTURE PAD STATION

Field: Surgery

LEARNING GOAL:

It was designed to mimic the layers and flexibility of the human body and practice suturing on it.

MATERIALS NEEDED:

- 2x Swiffer mop head paper
- or 2x sheets of cotton ball (batting)
- 2 × 3-inch ace bandage
- Tile/metal plate or brick
- Foam brick
- Felt (2x one bigger than the other)

Costs: ca. 5 EUR

Time: 1 day



INSTRUCTIONS:

- Step 1: Build the ‘dermis’ layer. Take the felt and fold it around the batting (cotton ball) and then attach it and sew it to the ace bandage and you do that twice. You now have two padded strips, which represent the two sides of the skin.
- Step 2: Create the Incision Simulation. Then put the two piece on top of each other, coloured sides (meaning the felt-side) together and sew the two sides of the ace together, a little bit over the

felt as well, but leaving enough space open in the middle. When you open this up later, it creates a flap simulating an incision in the skin.

- Step 3: Attach to Felt Backing Lay the felt sheet flat on your work surface and place the sewn-together skin flaps in the center of the felt. Fold one side of the batting/ace combination over, and sew along the edge onto the felt. Repeat for the other side. Now fold the outer edge of the ace bandages over again and sew down for clean finish.

- Step 4: Add the Foam and Weight Place the foam brick underneath the felt (on the bottom back). Add the brick or tile under the foam and hand-sew it over the

foam brick and brick/tile. Using a brick adds weight and stability.

THESE INSTRUCTIONS HAVE BEEN WRITTEN BASED ON THE FOLLOWING YOUTUBE VIDEO:

“Suturing Practice Station: What Goes into Making One” by First Assisting Techniques and Tricks: <https://youtu.be/isLG4V3D1FY?si=zP2N-wua-2E8OyA1e>

INSIGHTS FROM MARIJKE KRUIHOF, SENIOR MEDICAL EDUCATOR AT MAASTRICHT UNIVERSITY:

“When thinking about DIYs, it is also very important to think about the availability of materials that can be found locally. For example, we wanted to make a model to reproduce the feeling of the

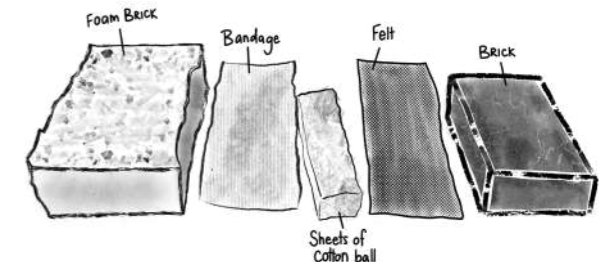

Illustrations by Giuliana Brancaleone

skin and make pads to practice suturing skills. Traditionally, commercial suturing models were made of thin leather, which can be expensive and not animal friendly. The model we made used the type of cloth that we use in the Netherlands to dry the windows after washing them. The commercial models are usually made with two or three times thicker materials than the actual skin, which means that students get a completely different feeling from reality when suturing with a needle. During a visit in Saudi Arabia,

we went to the local markets, and we went to feel the different types of sponges and cloths that they had to reproduce this model. The ones we found were all different from the ones in the Netherlands, and so we had to think further about other materials that were available in Saudi Arabia.”

Marijke Kruitbof, on the 19th of March 2025.

SIMULATOR FOR FLEXOR TENDON REPAIRS

Field: Surgery

THIS OBJECT WAS USED AT THE SKILLS LAB OF MAASTRICHT UNIVERSITY, THE NETHERLANDS.

- LEARNING GOAL:**
- Repair of tendon
 - Suturing of tendon

MATERIALS NEEDED:

- Glue sticks
- (Plastic) Ruler
- Marker
- Needle
- Thread

Cost: ca. 5 EUR
Time: 2-5 minutes

INSTRUCTIONS:

- Step 1: Tape two glue sticks about 0.5–1 cm apart on a plastic 30-cm ruler.
- Step 2: Sutures are intended to be placed in the substance of the glue sticks, which represents the tendon. To create a visual representation of the suture entry and exit sites, draw dots on the glue sticks with a permanent marker. This functions as

a guide for you to pass the suture material through.

- Step 3: With a needle and thread, practice suturing through the dots.

THESE INSTRUCTIONS HAVE BEEN WRITTEN BASED ON THE FOLLOWING ACADEMIC ARTICLES:

Burbamah, W., & AlShawaf, S. M. (2022). A Low-cost DIY Simulator for Flexor Tendon Repairs. *Plastic and Reconstructive Surgery—Global Open*, 10(12), e4726. https://journals.lww.com/prsgo/Fulltext/2022/12000/A_Low_

cost_DIY_Simulator_for_Flexor_Tendon_Repairs.22.aspx

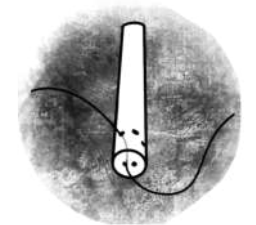

Illustration by Giuliana Brancaleone

SIMULATED MEMBRANES

Field: *Obstetrics*

THIS OBJECT WAS USED AT THE SKILLS LAB OF MAASTRICHT UNIVERSITY, THE NETHERLANDS.

MATERIALS NEEDED:

- 2 plastic gloves (or any small plastic bag available)
- Water
- The knitted uterus (see corresponding entry) (or any object in flexible material with a hole in which a small 'head' can pass through, e.g., the collar of a t-shirt)
- Baby doll (or any object to simulate the round head, e.g., a playing ball, a coconut)

Cost: ca. 1 EUR

Time: 2 minutes

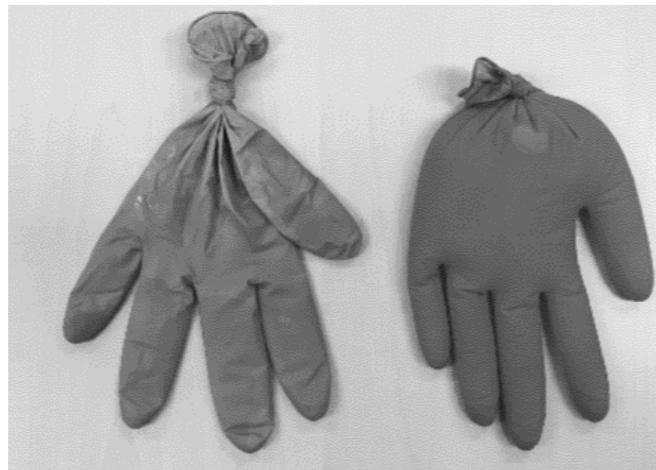

■ Photograph by Anna Harris.

INSTRUCTIONS:

- Fill one glove with a lot of water, and the other one with a little bit of water.
- Tie the gloves individually at the wrist level.
- Insert the baby doll in the knitted uterus (this simulates

the technique used to deliver a baby). See Knitted Uterus entry.

- Pull the doll's head out of the cuff of the knitted uterus (this demonstrates how the cervix widens at birth).

- Insert the glove filled with a lot of water over the doll's head and within the knitting

(this represents the feeling of when the membrane has not yet ruptured).

- Remove the first glove, and position the second one (with a little bit of water) in the same way (this represents the feeling of a membrane that has ruptured but is still intact over the cervix).

THESE INSTRUCTIONS HAVE BEEN WRITTEN BASED ON THE FOLLOWING ACADEMIC ARTICLES:

Harris, A., Rethans, J.J. *Expressive instructions: ethnographic insights into the creativity and improvisation entailed in teaching physical skills to medical students. Perspect Med Educ* 7, 232–238 (2018). <https://doi.org/10.1007/s40037-018-0446-5>

VAGINAL EXAMINATION WITH ORANGES AND SOCKS

Field: *Obstetrics*

THIS OBJECT WAS USED AT THE SKILLS LAB OF MAASTRICHT UNIVERSITY, THE NETHERLANDS.

Use oranges and socks to assess cervical dilation when practicing vaginal examination. By carving a round off the orange peel and positioning the orange in the neck of a sock, and inserting your fingers through the 'vaginal vault' (i.e., the neck of the sock), you can simulate a vaginal examination by guessing

with your fingers the cervical dilation on the oranges.

MATERIALS NEEDED:

- 3 oranges
- 3 socks
- Ruler
- Compass (or a string to draw a circle)
- Permanent marker
- Scalpel (or a knife)
- Tape

Cost: ca. 2 EUR

Time: 20 minutes

INSTRUCTIONS:

- Create the cervical diameter on the 3 orange peels:
 - Name the 3 oranges A, B and C respectively.
 - Tape the marker to the

compass.

- Use the centimeter ruler to set the compass to 2 cm (Orange A), and then 3cm (Orange B), and 4cm (Orange C).
- Press the compass needle point into the oranges at the center of the desired cervix.
- Trace the complete circles on the surface of the 3 oranges.
- Cut around the outline on the 3 oranges (avoid cutting the flesh of the fruit).

- Position the cervical model in the vaginal vault
 - Insert the oranges in the socks with the simulated cervix pointing up toward

the neck of the sock.

- Roll the neck of the sock to simulate the vaginal vault (leave 7-10 cm of tube from the end of the socks to the oranges)
- Simulate a vaginal exam by guessing the cervical dilation of the oranges
 - Insert two fingers in the neck of the sock.
 - Guess the orange diameter, of the cervical dilation with your fingers.

THESE INSTRUCTIONS HAVE BEEN WRITTEN BASED ON THE FOLLOWING ACADEMIC ARTICLES:

Shea, K. L., & Rovera, E. J. (2015). *Vaginal Examination Simulation Using Citrus Fruit to Simulate*

Cervical Dilation and Effacement. Cureus, 7(9), e314. <https://doi.org/10.7759/cureus.314>

WHAT DO MEDICAL STUDENTS THINK OF THIS MODEL?

"This DIY helped me to learn how to assess the cervical diameter with the help of oranges. I have never performed a vaginal

examination on a real patient but we have been practicing it on models. Doing it on the oranges was quite comparable and similar to the models we had in class. It was very easy to make this DIY, as I had all the materials at home, so it is a great exercise! The only

downside was that as I made the model myself, I knew the diameters already and so I was biased in my measurements. Whereas with the models at the SkillsLab, that is not the case."



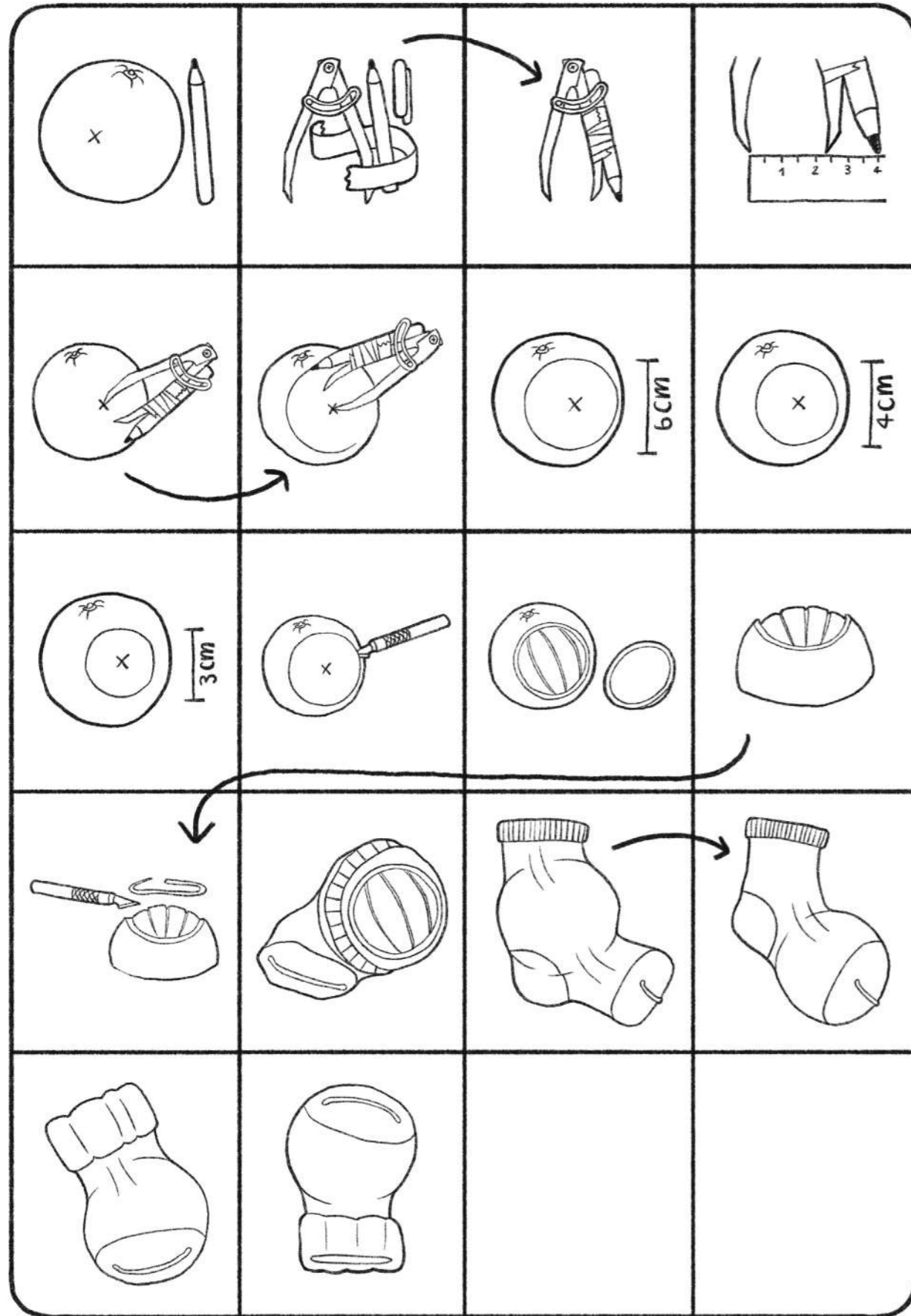

ULTRASOUND PHANTOM FOR SIMULATION TRAINING IN ABSCESS IDENTIFICATION AND ASPIRATION

Field: Dermatology

THIS OBJECT WAS USED IN THE UNITED STATES.

LEARNING GOAL:

To identify abscesses and practice using the ultrasound.

This phantom model aims to reproduce abscess-like structures in soft tissues with materials that are low-cost, easily accessible and locally available. It is designed to provide an opportunity for students to practice their eye-hand coordination in needle tracking and aspiration. Research has shown that when learners can safely practice recognizing pathology and performing procedures with point-of-care ultrasound (POCUS), their confidence and clinical performance improve. Therefore, having an affordable and replicable simulation model is essential for effectively training healthcare professionals in identifying and aspirating abscesses.

Text by Nyab Costa, based on the academic article: Wilson, J., Ng, L., Browne, V., & Lewis, R. E. (2017). *An Easy-to-Make, Low-Cost Ultrasound Phantom for Simulation Training in Abscess Identification and Aspiration*. *Journal of Ultrasound in Medicine*, 36 (6), 1241-1244. <https://doi.org/10.7863/ultra.16.04077>

MATERIALS NEEDED:

- 3 Tissue phantom gelatine
- Cherry-flavoured, sugar free Jell-O
- Sugar-free psyllium hydrophilic mucilloid fiber (sugar-free Metamucil)
- 12-inch balloons (4-5)
- 5-cc syringes Tapioca
- Opaque container
- Olive oil
- Gorilla Glue
- Ultrasound machine

Cost: ca. 10 EUR
Time: 7-10 hours



Illustration by Giuliana Brancaleone

INSTRUCTIONS:

- Step 1: The balloons were filled with tapioca or vanilla pudding using a 5 cc syringe. 2 or 3 ccs of olive oil was added to each balloon to decrease viscosity and increase ease of aspiration. Once the balloons were filled, all of the remaining air was removed from the balloons before tying them off. The balloons were then secured to the bottom of a large opaque red bin using Gorilla Glue (Gorilla Glue Co, Cincinnati, OH) or rubber cement.
- Step 2: After the balloons dried, we Low-Cost Ultrasound Phantom for Simulation Training in Abscess Identification and Aspiration 2 used the methods with cherry-flavored sugar-free Jell-O and sugarfree psyllium hydrophilic mucilloid fiber (sugar-free Metamucil [The Procter & Gamble Co, Cincinnati, OH]) to create simulated soft tissue that completely surrounds the secured balloons. Using this method, we used 6 ounces of sugar-free cherry flavored Jell-O and 3 tablespoons of sugar-free Metamucil.

- Step 3: Care must be taken to whisk vigorously when the ingredients are combined with the boiling water to limit precipitation.
- Step 4: The phantom was chilled in the refrigerator for 4 to 6 hours before use.
- Step 5: Once completed, the trainees were able to scan the phantom, track needle tips, and aspirate the balloon contents multiple times.
- Step 6: The phantom was kept in its container and refrigerated when not in use. If refrigerated, it can be kept in good condition for several weeks.

THESE INSTRUCTIONS HAVE BEEN WRITTEN BASED ON THE FOLLOWING ACADEMIC ARTICLE:

Wilson, J., Ng, L., Browne, V., & Lewis, R. E. (2017). *An Easy-to-Make, Low-Cost Ultrasound Phantom for Simulation Training in Abscess Identification and Aspiration*. *Journal of Ultrasound in Medicine*, 36 (6), 1241-1244. <https://doi.org/10.7863/ultra.16.04077>

3D PRINTED THORACIC EPIDURAL MODEL AND ASPIRATION

Field: Anesthesiology

THIS OBJECT WAS USED AT THE UNIVERSITY OF WASHINGTON, UNITED STATES.

LEARNING GOAL:

- Learning the placement of the epidural needle, with better visualization of the location of the needle tip with redirection at the skin. The transparent gelatine enhances visualization of the spine.
- Practicing an epidural procedure and getting a sense of the relevant tissues.

Epidurals are the most difficult procedure for beginning anesthesiology residents to learn. “Experts surveyed have found that one of the most challenging steps for novices when learning epidural placement is visualization of the location of the needle tip with redirection at the skin” and developing a feel for the relevant tissues (Han et al., 2020, p. 8). Commercial models are too

expensive and not easily available so apprentices appreciated this model as it helped them to learn this skill.

■ This text has quoted and has been adapted from: Han, M., Portnova, A. A., Lester, M., & Johnson, M. (2020). A do-it-yourself 3D-printed thoracic spine model for anesthesia resident simulation. *PloS one*, 15(3), e0228665. <https://doi.org/10.1371/journal.pone.0228665>

MATERIALS NEEDED:

- Polylactic acid (3D printer) for the thoracic vertebrae
- Thermoplastic polyurethane (3D printer) for the vertebral discs
- Epoxy
- Silicone moulding material for ligamentum flavum (Oomoo)
- Bubble tea straw
- Duct tape
- Ballistic gel for the cylinder of soft tissue around the spine
- Plastic container
- Refrigerator
- Wooden stand
- Screw and screwdriver

Cost: ca. 35 EUR (only for materials, this price excludes the potential costs associated with using a 3D printer and

purchasing necessary assembling tools).

Time: Ca. 40 hours (33 hours 40 minutes for the 3D printing and molding; 4 hours 50 minutes for the hands-on assembly time)

INSTRUCTIONS:

- Step 1: 3D print the vertebral discs in thermoplastic polyurethane.
- Step 2: Assemble together the discs and vertebrae with epoxy.
- Step 3: Fabricate the ligamentum flavum with a silicon moulding material (Oomoo): 3D-print a negative mould for the ligamentum flavum with PLA, then pour the Oomoo in the mould and remove after 6 hours.
- Step 4: Secure the ligamentum to a bubble tea straw and secure with duct tape, slide vertically into the vertebral canal.
- Step 5: Use a ballistic gel to create a cylinder of soft tissue around the spine that simulates the density and viscosity of human muscle tissues: 3D Printed Thoracic Epidural Model 2 submerge the spine

model in a plastic container filled with ballistic gel in liquid form and let solidify in refrigerator

- Step 6: Secure the model to a wooden stand with a large screw to be place through the lower vertebra. The model consists of 5 thoracic vertebrae and discs, the ligamentum flavum, and surrounding soft tissue. It is designed to be reusable: the ligamentum flavum and the soft tissue can be replaced between uses to ensure a fresh path for the needle.

THESE INSTRUCTIONS HAVE BEEN WRITTEN BASED ON THE FOLLOWING ACADEMIC ARTICLES:

Han, M., Portnova, A. A., Lester, M., & Johnson, M. (2020). A do-it-yourself 3D-printed thoracic spine model for anesthesia resident simulation. *PloS one*, 15(3), e0228665. <https://doi.org/10.1371/journal.pone.0228665>
 Bortman J, Baribeau Y, Jegathanan J, et al Improving Clinical Proficiency Using a 3 Dimensionally Printed and Patient-Specific Thoracic Spine Model as a Haptic Task Trainer Regional Anesthesia & Pain Medicine 2018;43:819-824.

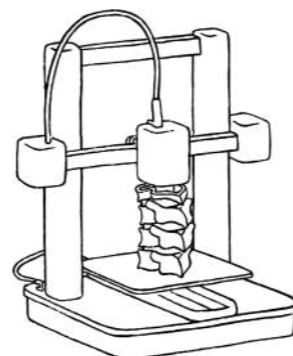
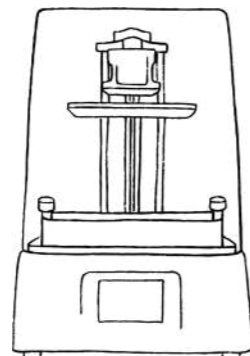
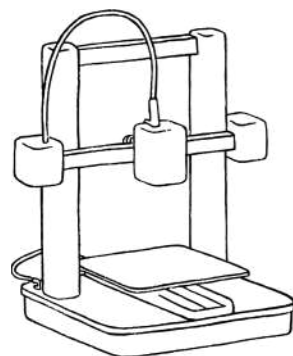

■ Illustrations by Emma Aitken

DETECTING ASCITES WITH A BALLOON

Field: Medicine

THIS OBJECT WAS USED AT THE SKILLS LAB OF MAASTRICHT UNIVERSITY, THE NETHERLANDS.

This DIY model can be used when training second year medical students to perform abdominal examinations, and detect signs of underlying pathologies, like ascites. Ascitis involves the presence of ascitic fluids, which is a condition that occurs when fluids accumulate in spaces of the patient’s abdomen, where there should not be any fluid. To check for ascites and the presence of ascitic fluids, the patient’s abdomen has to be examined, and the doctor has to check for “shifting dullness”. In a tutorial setting,

“the student (performing being doctor) percusses (taps) the abdomen and listens to the sound: dull sounds signify an underlying solid structure or fluid, whereas the gas-filled bowels produce hollow, drum-like tympanic sounds. Ascitic fluid sinks with gravity, while the gas-filled loops of the bowel rise. Changing the patient’s position will therefore cause free-flowing fluid to reposition as well, causing dullness to be heard where it previously was not: shifting dullness” (den Harder & Harris, 2022, p. 1). However, as ascitis is an underlying condition, checking for ascitic fluids, or shifting dullness, in a tutorial cannot be performed on healthy students. Therefore, the DIY balloon model provides a more representative example of the sounds heard when ascitic fluids are

present inside the patient’s abdomen. This DIY is also more helpful than textbook drawings for two reasons: on the one hand, the balloon is slightly transparent, and so the water inside is somewhat visible; on the other hand, the balloon can be moved around and the water in the abdomen, which allows to visualize the changes in positions of the fluids, unlike a 2D textbook drawing could.

MATERIALS NEEDED:

- 1 inflatable balloon (birthday-type balloon) (alternatively, you could also use a small plastic bag filled with air)
- Water

Cost: ca. 50 cents
 Time: 1 minute

■ Photographs by Anna Harris.



INSTRUCTIONS:

- Fill the balloon partially with water.
- Secure the balloon with a simple knot
- Practice the examination of shifting dullness and making percussion sounds to hear the presence of fluids in the balloon.

THIS ENTRY HAS PARAPHRASED THE WORK OF:

den Harder, C., & Harris, A. (2022). *Lessons from a Balloon*. In J. Nott & A. Harris (Eds). *Making Sense of Medicine*. London.



LAPAROSCOPIC HOME TRAINER BOX

Field: Surgery

THIS OBJECT WAS USED AT THE UNIVERSITY OF PECS, MEDICAL SCHOOL IN HUNGARY.

Practice your laparoscopy skills at home with this model, and strengthen your hand-eye coordination skills. This model allows students to practice these skills outside of the classroom and was created during a COVID-19 lockdown context.

- Small booklet (that fits in the box)
- Scissors (or cutter)
- Phone with a webcam app that has a flash (ex: DroidCam, IP WebCam, EpocCam); (this can also work with only a physical WebCam and a bicycle light)
- Laptop/ tablet

This model allows for great flexibility and material adaptability anywhere in the world, and promotes the reuse of objects present in the

MATERIALS NEEDED:

- Shoebox (any large box to reproduce a pelvitrainer box)
- Set of small objects:
 - Small toys/ figurines
 - Coin
 - Beans (dry)
 - (or any small object that would allow you to practice the same skills: small fruits, beads,... the smaller and smoother the object, the harder the exercise).
- Wooden spoons (any usable stick to reproduce laparoscopic tools that is rigid, at least 20 cm long and has a diameter of not more than 2cm)
- Sheet of paper

home/office in a sustainable way. The main limitation of the model is the requirement for a laptop/tablet to have a visual image of the inside of the box and practice hand-eye coordination skills.

Cost: The objects used in this model can be found around the home/office, the only costly materials are the laptop and the phone.

Time: 5 minutes for the assembly time, and then as long as needed for the skills training



LAPAROSCOPY (medical procedure, field: surgery)

Refers to a procedure that permits visual examination of the abdominal cavity and organs with an optical instrument called a laparoscope, which is inserted through a small incision made in the abdominal wall, and moved around the abdomen for examination.

(from Greek laparo, meaning “flank”, and skopein, meaning “to examine”).

DICTIONARY DEFINITION
Britannica (2025)

INSTRUCTIONS:

- Install the WebCam app on your phone, and connect it to your computer (or connect the physical WebCam to your computer).
- Cut a hole the size of your phone (or WebCam) on the shorter side of the box, and slide in your phone (or WebCam) inside the box.
- Cut 2 holes on the lid of the box to pass your laparoscopic tools (wooden spoons) inside the box. These holes should be 3-5 cm from the sides of the box, and 10cm from each other.
- Create a set of laparoscopic environments to practice your laparoscopic skills. To do so, use the webcam of the phone connected to your laptop to see what you do inside the box, and direct yourself following the webcam video.

This allows you to practice your hand-eye coordination, and triangulation skills.

- Create any of the following laparoscopic environments:

- A hole-wall: use a sheet of paper and cut 4-6 holes the size of a coin (a little bit larger than the diameter of your laparoscopic instrument (wooden spoon)), number the holes and insert the sheet inside the box by bending it to have an oblique orientation. The goal of this hole-wall is to dig your laparoscopic tools in each of the holes following their order, without touching the wall (sheet of paper).

- Coin and toys: place the coin in the center of the box, and the small toys and dried beans around inside the box, then close it. With your laparoscopic tools, try to grab

the small toys and beans and place them on top of the coin. The smaller and smoother the objects (like the dried beans), the harder the exercise.

- Booklet: place the booklet inside the box and practice turning over the pages with your laparoscopic tools.

THESE IMAGES HAVE BEEN TAKEN AND INSTRUCTIONS HAVE BEEN WRITTEN BASED ON THE FOLLOWING ACADEMIC ARTICLE

(USED UNDER CREATIVE COMMONS CC-BY LICENSE):

Schlégl, Á.T.; Pintér, Z.B.; Kovács, A.; Kópjár, E.; Varga, P.; Kardos, D.; Berner-Jubos, K.; Maróti, P.; Füzési, Z. *Distance Education for Basic Surgical Skills Using Homemade Tools—DIY Methods for Emergency Situations. Sustainability* 2022, 14, 8639. <https://doi.org/10.3390/su14148639>

Video: DIY tools for laparoscopy, visual representation by the authors: <https://www.mdpi.com/article/10.3390/su14148639/s1>

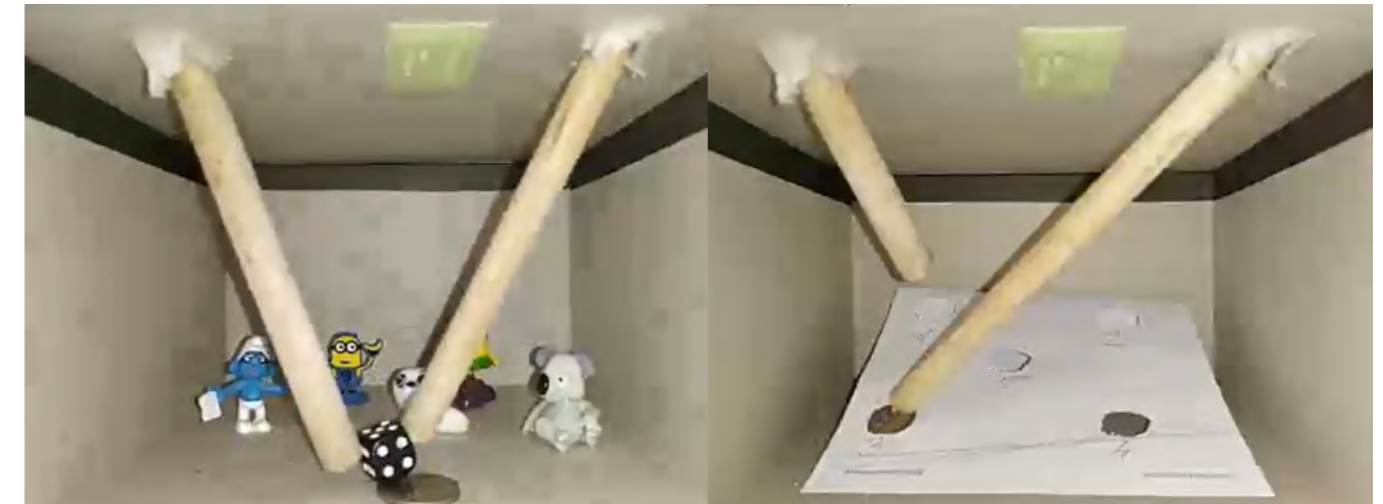
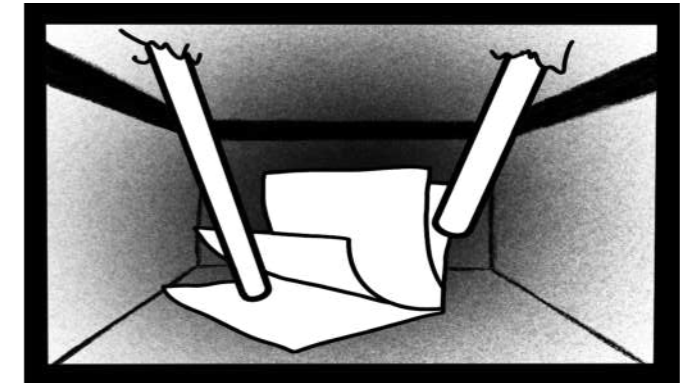

ANATOMY DIYS TO HELP YOU SEE

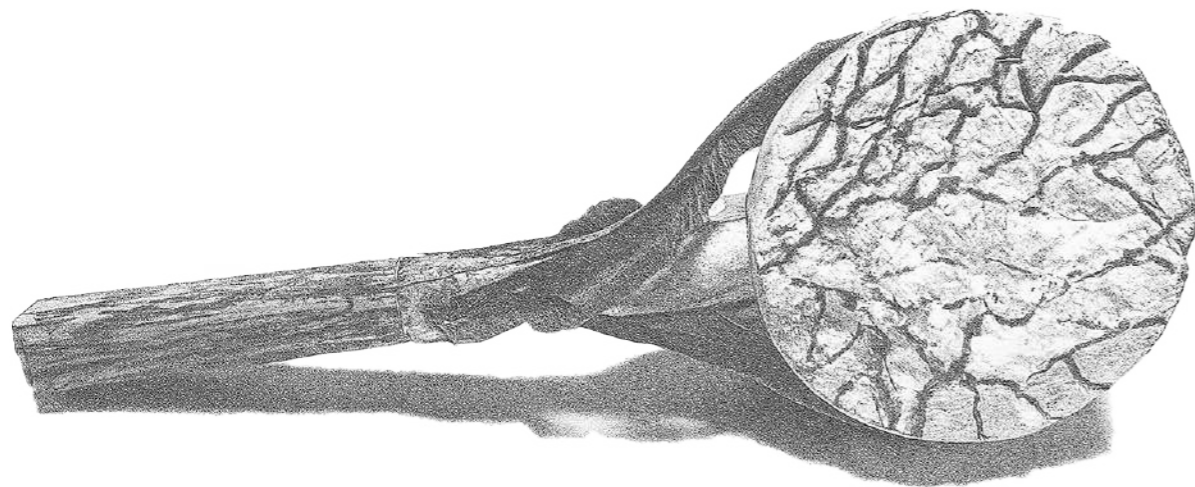

[Observational Skills]

The second section of the catalogue has DIYS that will help you see, visualise, and understand the anatomy of our bodies' organs and their various functions. Make these DIYS to either create new humanlike anatomical models, or to reproduce the underlying movements and mechanisms behind our organs. Again, think outside of the box, and let new materials teach you about your body in surprising ways.

PAINTED WOUNDS

Field: Surgery

Another method was introduced by Luchacha, which involves creating different types of simulated wounds to help students learn how to identify and treat them. She explained that they use makeup, and other cosmetics people usually apply to their faces, to create realistic-looking wounds. For each type

of wound, the appropriate dressing will be discussed and explained, meaning the material and method used to cover and protect the various wounds. For instance, what to do with an infected wound, or how to treat a necrotic or fresh wound. Luchacha explained that the wounds look very real, even though they are made from simple materials, like oils and even flour, used for cooking chapati. They

designed several wound types: one bleeding wound, a highly infected wound, a swollen wound, and another that looked like a fresh cut. She encourages the students to also help create the wounds, and then use them to practice the different wound conditions. By doing it hands-on, like using tweezers and other tools, they learn more effectively. Luchacha explained that with these models, "it is easy for

them to learn and it will stick in their brain." The experience sticks with the students because they are actively involved, not just observing already-made models.

■ Elizabeth Luchacha, from an online interview conducted by Giuliana Brancaleone and Nyab Costa on the 13th of March 2025

KNITTED UTERUS

Field: Obstetrics

LEARNING GOAL:

- Shows the movements and dilations of the uterus, vagina and cervix during a baby delivery
- Demonstrates how labour contractions work

The knitted uterus model is a visual teaching tool that can be used by midwives, childbirth educators and others to explain how a baby is delivered. The uterus is made from yarn and shaped to mimic its real-life structure, including a cervix. Additionally, if available you can use a doll to demonstrate the dilated cervix.

To demonstrate labour contractions, gently pull from the top of the uterus, simulating how the uterine muscles tighten from the top down during a contraction. During the progress of these "contractions", you can show how they help push the baby downward. The

cervix is knitted as a circular opening at the bottom of the model. It can be gradually opened wider to represent cervical dilation, from closed to fully dilated, showing how the baby is birthed.

■ This text has been written by Giuliana Brancaleone and Nyab Costa (based on the YouTube videos listed below).

MATERIALS NEEDED:

- Double knitting wool/yarn – 3 oz
- 4 Knitting needles pointed at both ends size 8
- Small quantity shirring elastic
- Round balloons
- 1 plastic ball 3½" diameter (three and a half inches)

Cost: ca. 4 EUR

Time needed: 5-10 hours

INSTRUCTIONS:

- Step 1: Cast on 48 stitches 16 on each of 3 needles. Join.
- Step 2: Knit 2, Purl 2, until cuff measures two and a half

inches. Continue in plain knitting.

■ Step 3:

Increase

- 1st ROUND Increase 1 stitch in every 6th stitch (56 stitches). Knit 7 rows plain knitting.
- 8th ROUND Increase 1 stitch every 7th stitch (64 stitches).
- 15th ROUND Increase 1 stitch every 8th stitch (72 stitches).
- 22nd ROUND Increase 1 stitch every 9th stitch (80 stitches).
- 29th ROUND Increase 1 stitch every 10th stitch (88 stitches).
- 36th ROUND Increase 1 stitch every 11th stitch (96 stitches).
- 43rd ROUND Increase 1 stitch every 12th stitch (104 stitches).

■ Step 4:

Continue to knit on these 104 stitches for another 25 rounds.

■ Step 5:

Decrease

- 1st ROUND *knit 11 slip 1 knit 1, pass slip stitch over. Repeat from * to end of row.
- 2nd ROUND *knit 10 slip 1 knit 1, pass slip stitch over. Repeat from * to end of row.
- 3rd ROUND *knit 9 slip 1 knit 1, pass slip stitch over. Repeat from * to end of row.
- 4th ROUND *knit 8 slip 1 knit 1, pass slip stitch over. Repeat from * to end of row.
- 5th ROUND *knit 7 slip 1 knit 1, pass slip stitch over. Repeat from * to end of row.
- 6th ROUND *knit 6 slip 1 knit 1, pass slip stitch over. Repeat from * to end of row.
- 7th ROUND *knit 5 slip 1 knit 1, pass slip stitch over. Repeat from * to end of row.
- 8th ROUND *knit 4 slip 1 knit 1, pass slip stitch over. Repeat from * to end of row.
- 9th ROUND *knit 3 slip 1 knit 1, pass

slip stitch over. Repeat from * to end of row.

- 10th ROUND
- *knit 2 slip 1 knit 1, pass slip stitch over. Repeat from * to end of row.
- 11th ROUND
- *knit 1 slip 1 knit 1, pass slip stitch over. Repeat from * to end of row.
- 12th ROUND
- *Slip 1 Knit 1. Repeat to end of stitches.

■ Step 6:
Cut the wool. Draw the end through the remaining eight stitches and finish off. Thread a few strands of shirring elastic around the top and bottom of the cuff.

THESE INSTRUCTIONS WERE COPIED FROM THIS FOLLOWING WEBSITE:

“Pattern for knitted uterus” by Wise Woman Way of Birth
<https://wisewomanwayofbirth.com/pattern-for-knitted-uterus/>

FOR FURTHER INSIGHT READ FOLLOWING ARTICLE:

Harris, A. (2021). *On the fabric of the human body in seven text-iles: The multimodality of learning anatomy*, *Multimodality & Society* 1 (1): 8-19.
<https://journals.sagepub.com/doi/full/10.1177/2634979521992325>

THESE FOLLOWING YOUTUBE VIDEOS DEMONSTRATE HOW TO USE THE KNITTED UTERUS:

Knitted Uterus demonstration by Crafty Lucy: <https://www.youtube.com/watch?v=ISiNggHRLDM>

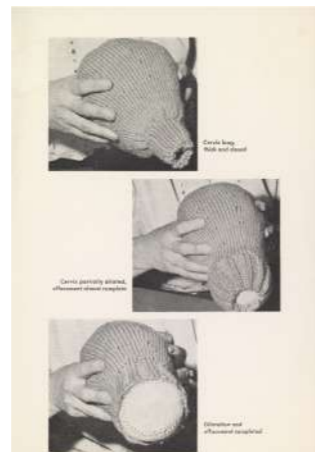

■ Photographs by Anna Harris.

WHEN FEMINISM ENTERED THE MEDICAL CLASSROOM

During the second half of the twentieth century, the second wave of the feminist movement advocated for gender equality, also in healthcare and medical education (Shai et al., 2021). The ideas supported by the feminist movement during that period included pushing for more research and education on the female body and biological system, thereby redirecting the medical male gaze to more gender equal practices and improving specialized medical treatments for women. Through these ideas, DIY objects like the knitted uterus entered the medical classroom. Compared to the high-fidelity obstetric models, this DIY offers the

possibility to visualize and feel the process of giving birth, in a more organic and fluid way, and can be transported to be used anywhere, especially outside medical faculties (Nott & Harris, 2020).

■ Nyab Costa

FURTHER READING AND REFERENCES:

Nott, J., & Harris, A. (2020). *Sticky models: History as friction in obstetric education*. *Medicine Anthropology Theory*, 7(1). <https://doi.org/10.17157/mat.7.1.738#>

Shai, A., Koffler, S., & Hashiloni-Dolev, Y. (2021). *Feminism, gender medicine and beyond: a feminist analysis of “gender medicine”*. *International Journal for Equity in Health*, 20(1). <https://doi.org/10.1186/s12939-021-01511-5>

INSIGHTS FROM THE LITERATURE:

John Nott and Anna Harris (2020) wrote on the knitted uterus, its history and use in the modern medical classroom. Their article illustrates how gender is a clear factor in the discussion of medicine, particularly as it relates to femininity in the traditionally male-dominated area of medicine. The knitted uterus appears to have its conceptual roots in mid-twentieth century “women’s health” movements, which were sparked by women’s requests for greater medical information about their own bodies and by broader cultural and medical shifts that have been attributed to second-wave feminism (Harris and Nott, 2020). This further

shows the medical exclusion of the female body in medicine. According to Harris and Nott, there was discussion on the fact that male surgeons would ostensibly not profit from such a basic explanation of female anatomy. Therefore, the exclusion was not only practices that were connotated with femininity, but the female body as a whole. They show in the essay that incorporating practices into the discourse of medical teaching requires more than just establishing their relevance; it also requires a deconstruction of the hegemonic norms in the medical practices, which are fundamentally masculine. It follows that the (re) introduction of DIY creating tools operates on several levels and that additional

deconstruction of knowledge and power production is required to put the tools into practice. According to Harris and Nott, representations of female anatomy have historically represented the dominant male perspective in medical practice. Harris and Nott conclude that challenging histories of misogyny and imperialism are still present in modern medicine and are reinforced by the continuous use of educational simulators in medical schools. They contend further that we can only start to alter the problematic past by paying attention to the material, cyclical replication of it. This further supports the claim that the emergence of DIY tools necessitates a reevaluation of the way in which knowledge is produced in medicine.

One important thing to keep in mind is that culture and conventions also shape the discourse in medicine. Power and the creation of knowledge go hand in hand.

■ Giuliana Brancaleone

FURTHER READING AND REFERENCES:

Nott, J., & Harris, A. (2020). *Sticky models: History as friction in obstetric education*. *Medicine*

Anthropology Theory, 7(1). <https://doi.org/10.17157/mat.7.1.738>

DIRECT QUOTES:

“When it comes to teaching novices the techniques, anatomy, and sheer physics of delivering a baby, teachers face a common conundrum. When it is either too difficult, dangerous, or inappropriate to be involved in actual deliveries, how can educators simulate the slipperiness and mess; the internal movements of the baby that are not visible to the eye; the way a woman’s body changes during labour, with her pain and pushing; or the awkwardness of handling instruments?” (pp. 44-45)

■ Nott, J., & Harris, A. (2020). *Sticky models: History as friction in obstetric education*. *Medicine Anthropology Theory*, 7(1). <https://doi.org/10.17157/mat.7.1.738>

“In the medical school in Maastricht, the ‘Skillslab’ is a standalone building with room enough to be divided up by specialty. Each room is filled with intriguing models and simulations, like toy cupboards for grown-ups wanting to be real doctors. In the obstetrics room there are shelves of labelled leather legless trunks, with hollow

spaces and zippered vaginas for cloth babies to squeeze through. The secretaries at the Skillslab care for the models with leather conditioner and hand stitch repairs using leftover surgical twine. There is a large plastic doll lightly coated in years-old glycerine, sticky from many attempted births; and also a plastic placenta, more lifelike to handle than a cloth one, and easier for moving through the models. But for the authors, as for many of the staff, a favourite is the knitted uterus. Lying unceremoniously in a drawer in the little room, this is a well-worn and well-loved object. About as long as a forearm, it is knitted in coarse red wool, using a mixture of ribbed and lace stitching.

The lesson with the knitted uterus goes as follows: a baby doll is inserted into the bulk of the uterus, its head slightly protruding. The teacher then shows how the cervix (i.e., the ribbed cuff) dilates as the head comes through, so that it not only gets wider, but also stretches thin. This helps to show the students something that they cannot see since it is happening inside the body. It is also a way of showing the different positions the baby’s

head may take as it descends. While a teacher might talk about the big fontanelles and the small fontanelles (the soft gaps between a baby’s cranial bones) as well as their various positions, this model allows students to see and touch what they should expect to feel. Compared to using diagrams in textbooks to teach these processes, the teachers find using this model to be much more dynamic and simple. The lesson then becomes more complicated. The teacher takes two blue latex gloves, filling one with a lot of water, and one with less [this is the Simulated Membranes DIY, p. 9]. She then places the full glove over the baby doll’s head, tucking the fingers of the glove into the cuff. A student is asked to feel the bulging glove over the head – this is what intact membranes feel like, they are told. Then the teacher inserts the other glove. Again, a student feels the rubbery bulge – this is what it feels like if the membranes have ruptured higher up, elsewhere in the uterus, but are still intact over the cervix.” (pp. 48-49)

■ Nott, J., & Harris, A. (2020). *Sticky models: History as friction in obstetric education*. *Medicine Anthropology Theory*, 7(1). <https://doi.org/10.17157/mat.7.1.738>

FEMALE REPRODUCTIVE SYSTEM MODEL

Field: *Obstetrics*

LEARNING GOAL:

To teach about the anatomy of the reproductive system

This model helps as a visualizer, allowing students to physically see and touch the different components of the female reproductive system. By building this model, students can gain a deeper understanding of the anatomy

and spatial relationships between these organs. Creating this model out of Thermocol (Styrofoam) or similar material, is an excellent hands-on learning tool for medical students.

MATERIALS NEEDED:

- Thermocol/ Styrofoam Sheet (1 inch thick)
 - Thermocol is lightweight, easy to shape, and can be carved or molded into the detailed structures.

- White Glue
 - Cutting Blades
 - Tissue
 - Colours (Poster or Acrylic Paint)
 - Water
 - Brushes
- Cost: 10 EUR
Time: 1-2 hours

INSTRUCTIONS:

- Step 1: Lay out a 1 inch (2.5 cm) thick styrofoam sheet.
- Step 2: Draw the outline of the female reproductive system.

- Step 3: Cut out the outlined shape of the styrofoam sheet.
- Step 4: Draw in the details of the female reproductive system, and indicate the areas that need to be carved.
- Step 5: Start carving the female reproductive system into its correct shape.
- Step 6: Take a new piece of styrofoam and draw the shape of the ovaries (x2)
- Step 7: Cut out the ovaries, carve

them into shape and attach them to the main structure.

- Step 8: Colour in the model to reflect the various areas of the female reproductive system.

THESE INSTRUCTIONS HAVE BEEN WRITTEN BASED ON THE FOLLOWING YOUTUBE VIDEO:

“Making Female Reproductive System Model” by BioMedical Art
<https://youtu.be/2cDUoOjdg8M?si=rTo04voOWyV5roG6>

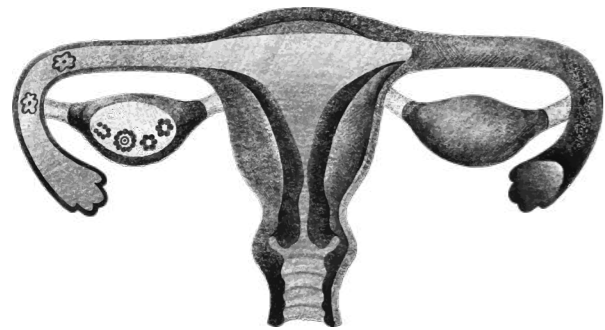

■ Illustration by Emma Aitken.

SECOND SKIN FIDELITY MODEL

Field: Anatomy, Dermatology

THIS OBJECT WAS USED AT THE UNIVERSITY OF PRETORIA, SOUTH AFRICA.

INSIGHTS FROM A PHD STUDENT IN ANTHROPOLOGY BASED IN SOUTH AFRICA:

“The Skin Fidelity Model is a DIY object made from easily accessible materials to visualize different types of skin and conditions. In short, you create a mold in clay and then you gradually add layers of more flexible materials (e.g., silicone), adding pigments for skin types and texture for skin conditions. Most students learn from textbooks, so they don’t actually have a physical representation of

what the actual condition can look like or how it actually feels to the touch. By using these models, the students can at least have an idea of how it would actually look like on a person. It would also be a good idea to consider having the students make those skin models themselves, as the process of creating the model can help them learn about the different layers of the skin and various skin conditions.”

■ *PhD student, on the 20th of March 2025.*

■ *Image is from the Creating Skin Fidelity Models project document.*

MATERIALS NEEDED:

- Non-drying modelling clay (different colors if possible)
- Silicone rubber
- Polyol (material)
- Isocyanat (catalyst)

- Casting plaster
- Release agent
- Pigments (colors for the mixtures)
- Framed cardboard
- Cardboard box or sheets to fit in perfectly the framed cardboard
- Plastic wrapping film
- Any point object (brush, pen, fork)
- Glue gun
- Water

Cost: 30-50€
Time: a few hours



INSTRUCTIONS:

- Step 1: Create a 3D replication of the skin with the condition of interest using non-drying modelling clay
 - Smooth a layer of clay on framed cardboard/wood
 - Onto the clay model, lightly outline the areas or lesions by adding mode clay (as indicated on the image). Different colors of clay can be used to outline the different conditions visible on the skin.
- Step 2: Add texture to the clay model so that it resembles skin (like skin pores and lines)
 - Cover the clay model with plastic wrapping film, use a blunt pointy object to pinpoint and draw lines on the film, to recreate pores and skin lines.

- Step 3: Remove the plastic film around the clay
- Step 4: Create a mould to border the clay model
 - Glue the clay model on a cardboard surface, and use cardboard sheets to create a border around the model to prevent any leakages when layering in the mould mixtures. Glue them with the glue gun.
- Step 5: Create a silicone mould:
 - Mix 300-400 g of silicone rubber with catalyst (10% of silicone) and then add pigments to

- give the silicone mould color.
 - Layer the silicone rubber mixtures on the bordered clay model.
 - Let it dry.
- Step 6: Create a resin mould using polyol (material) and Isocyanat (catalyst)
 - Mix 100 g of each agent with a 1:1 ratio.
 - Layer the resin mixture onto the silicon mould on the bordered clay model.
 - Let it dry.
- Step 7: Create a plaster mould
 - Mix casting plaster with

- water until you have a white watery liquid.
 - Spray a release agent on resin mould to easily separate the moulds when the plaster has set.
 - Layer mixture on the bordered clay model, thus this time on the resin mould.
 - Let it dry.
- Step 8: Add texture and color to the moulds
 - Using the plaster mould: add colours layer by layer (first wait for the underlying layer to dry before adding the next layer).

- Using the silicone rubber (Ecoflex 00-20 A and B) to add texture to resemble model of interest: Mix Part A and B with a 1:1 ratio and then add pigments for colours.

THESE INSTRUCTIONS HAVE BEEN WRITTEN BASED ON THE FOLLOWING PROJECT DOCUMENT, WHICH HAS BEEN SHARED WITH US BY THE AUTHOR DURING AN INTERVIEW:

Prof. E.N. L'Abbe and Thandolwethu Mbonani, Creating Skin Fidelity Models, University of Pretoria, South Africa.



EYE MODEL

Field: *Ophthalmology*

LEARNING GOAL:

Craft a 3D model of the human eye with easily available materials to understand its anatomy.

MATERIALS NEEDED:

- a small foam ball for the eyeball (or any sphere in which you can pick the wooden stick)
- a foam square (for the base)
- a foam sheet to make the eye muscle (or any resistant paper)
- a wooden stick (or a straw, toothpick)
- a goggle eye (to make the cornea)

- toilet paper roll (to make the optic nerve)

- paints (or markers to avoid drying times; colors: red, black and blue/brown (for the iris))
- glue

Cost: *under 10 EUR*
Time: *under 1 hour*

INSTRUCTIONS:

- Use the foam ball to make the eyeball
- Color the iris in your color of preference, and the pupil in black
- Use the goggle eye to make the cornea: cut the clear

plastic part off and glue it to the iris on the foam ball

- To represent the ciliary artery: color half of the foam ball with red color (like on the images)

- To make the optic nerve: use the toilet paper roll, cut it in half and roll the sheet of cardboard, then attach it to the foam ball (the eyeball)

- To make the eye muscle: use the white foam sheet (or resistant paper), cut 4 strips, and color with red, glue them to the eyeball

- Make a stand for display: use the square foam and the

wooden stick, pick the stick into the eyeball and pick the whole eye into the square foam

THESE INSTRUCTIONS WERE PARAPHRASED FROM THE FOLLOWING ENTRY:

Nicekazi on Instructables (How to Make 3D Human Eye Model: Easy Way - Instructables)

- *Instruction guide by Emma Aitken*

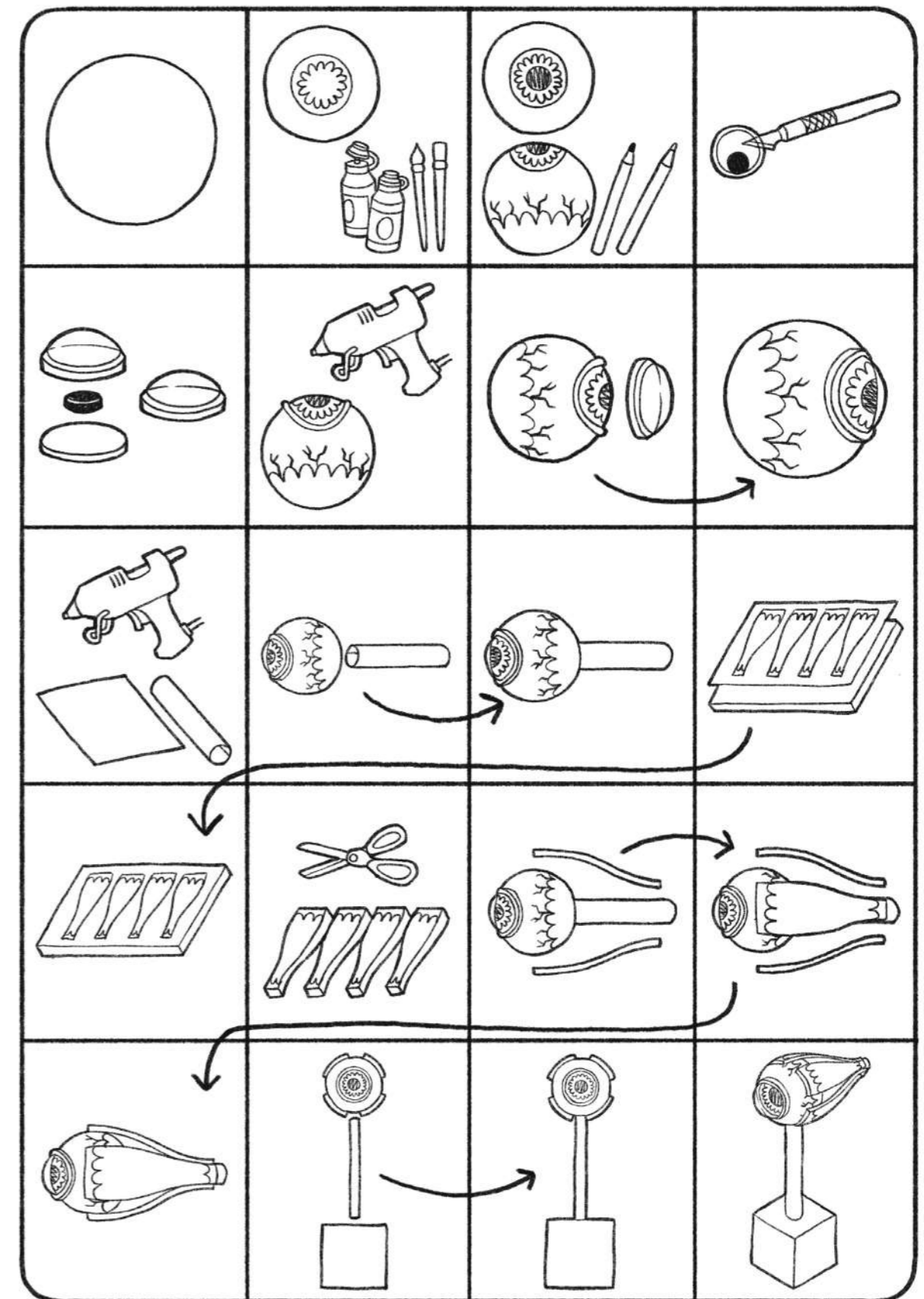

CLAY HEART MODEL

Field: Cardiology

THIS OBJECT WAS USED AT SUNGKYUNKWAN UNIVERSITY SCHOOL OF MEDICINE, SOUTH KOREA.

Build a 3D model of the human heart in clay to understand the heart's cross-sectional anatomy. This model can also be cut in half, mirroring a 2D CT scan of the heart; this allows students to learn how cross-sectional 2D CT images were created from 3D structures of human organs.

- As alternative: plasticine, Fimo play-dough, or make your own air-drying clay (4 cups of baking soda, 2 cups of cornstarch, 2 ½ cups of water), or salt-clay (2 cups of flour, 1 cup of salt, 1 cup or warm water), and paint after modelling

Cost: 8 EUR
Time: 1 hour

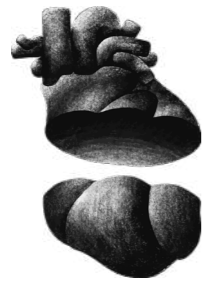

■ Illustration by Emma Aitken

MATERIALS NEEDED:

- Air modeling clay (7 different colors)

INSTRUCTIONS:

- By following a 3D model of the human heart, craft each heart section individually (in different clay colors, or paint later on).
- Assemble all the pieces to build the clay heart model.
- Identify the different parts of the heart: Superior vena cava (SVC), Aorta, Right Atrium (RA), Left Atrium (LA), Right Ventricle (RV), and Left Ventricle (LV).
- Cut the model in half horizontally to perform a cross-section cut of the heart.
- Identify the Right Atrium (RA), Left Atrium (LA),

Right Ventricle (RV), and Left Ventricle (LV).

THESE INSTRUCTIONS HAVE BEEN WRITTEN BASED ON THE FOLLOWING ACADEMIC ARTICLE:

Oh, C. S., Kim, J. Y., & Choe, Y. H. (2009). Learning of cross-sectional anatomy using clay models. *Anatomical sciences education*, 2(4), 156–159. <https://doi.org/10.1002/ase.92>

TOOTH MODEL

Field: Dentistry

This model reproduces a human tooth in 3D for students to learn its basic anatomy through visualization

MATERIALS NEEDED:

- 3 Styrofoam Sheet (1 inch thick)
- White Glue
- Cutter (or knife with sharp blade to carve)
- Paper tissues (or toilet paper)
- Colours or paints
- Water
- Brushes
- Pen

Cost: ca. 6 EUR
Time: 1 hour

INSTRUCTIONS:

- Step 1: Lay out a 1 inch thick block of styrofoam.
- Step 2: Draw the outline of a human tooth on one styrofoam sheet (see tooth outline below).
- Step 3: Draw another outline of a human tooth, but this time only the top half of the tooth. Then, cut out both pieces.
- Step 4: Align the two cut out styrofoam sheets and glue them together.
- Step 5: Start carving out the shape of the tooth on the backside of the model to resemble a 3D tooth model.

- Step 6: Take a new styrofoam sheet and cut out the inner part of the tooth (which resembles the bottom of the tooth but in a smaller size).
- Step 7: Stick the inner part of the tooth on the bottom part of the main tooth model. Carve out its edges.
- Step 8: With the brush and white glue, add texture to the model by applying paper tissues and painting over them with the white glue.
- Step 9: Paint the model according to a tooth model visual.

THESE INSTRUCTIONS WERE WRITTEN BASED ON THE FOLLOWING YOUTUBE VIDEO:

Khadija Fazal Karim (2020). *Section of Tooth Model DIY, BioMedical Art, YouTube Video.* https://youtu.be/xBhws1WBXNM?si=P4G-KS45yOh_oQpyh

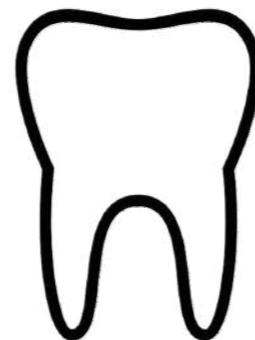

DIGESTIVE SYSTEM MODEL

Field: Anatomy, Surgery

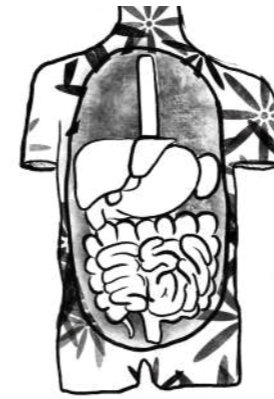

■ Illustration by Giuliana Brancaleone.

This model represents the human body's digestive system in 3D and allows us to visualize the different organs and their interconnections. The body parts and organs part of the digestive system reproduced in this model include: the oesophagus, the liver, the stomach, the bladder, the spleen, the duodenum, the pancreas, the large and small intestines, the rectum and the appendix.

This model can be adjusted to different locations and contexts by changing the color used to represent the model's skin color and seeking material

alternatives. Indeed, any alternative to styrofoam that can be carved can be used for this model. It is also possible to use cardboard sheets as the main material: instead of carving out the styrofoam, the different cardboard pieces can be glued on top of each other to reproduce the 3D effect of the model.

■ This text has been written by Giuliana Brancaleone and Nyab Costa.

MATERIALS NEEDED:

- 3 Styrofoam Sheet (48 × 35 cm; 5-7 cm thick)
- Cutter (or cutting blades)
- Paper tissue (or toilet paper)
- Colors or paints (colors needed: skin color, red, yellow, brown, green, orange, light blue; these can be mixed from red, yellow, blue and white)
- White glue
- Water
- Brushes
- Pen

Cost: ca. 8 USD
Time: 1-2 hours

INSTRUCTIONS:

- Step 1: Lay out three styrofoam

sheets. Draw an outline of the human upper-body on all three sheets and cut them out.

- Step 2: On two of those upper-body shapes, draw a large oval of where the abdomen is situated and cut them out. Keep the last upper-body shape "full".

- Step 3: On the first oval shape, draw the digestive system and include the following organs: the oesophagus, liver, stomach, bladder, spleen, duodenum, pancreas, large and small intestines, rectum and appendix. Cut the whole system out and use your cutter to carve the edges of the digestive system nicely.

- Step 4: On the second oval shape, do the same but only draw the liver, stomach and both intestines. Cut them out/

- Step 5: Glue the second liver, stomach and intestines on the first digestive system (made in step 4). This adds depth to the model. Carve the edges nicely to reproduce the 3D effect of the digestive system.

- Step 6: Take the first styrofoam sheet upper-body shape. Glue the second and third ones with the oval holes on top of the first one sheet. Carve the edges of the upper-body nicely.

- Step 7: Take the full digestive system. Use the white glue and brushes to paste paper tissues on top of the styrofoam material. Let the model dry and then paint the organs using your color paints according to any digestive model.

- Step 8: Place the coloured digestive system within the model of the human upper body, and colour in the upper-body as indicated.

THESE INSTRUCTIONS HAVE BEEN WRITTEN BASED ON THE FOLLOWING YOUTUBE VIDEO:

Khadija Fazal Karim (2019). *How to make Digestive System 3D model, BioMedical Art, YouTube Video.* https://youtu.be/vblOn_pStYg?si=t-LisLVkUwRA7N-3K

■ This text has been written by Giuliana Brancaleone and Nyab Costa.

MATERIALS NEEDED:

- Plastic bottle with cap
- Scissors
- Stationary knife
- 3 balloons
- 2 narrow straws

LUNGS MODEL

Field: Respiratory Medicine

LEARNING GOAL:

- Learning how the lungs and diaphragm move
- Respiratory process

This model is a simple yet effective way to demonstrate

how the lungs and diaphragm move during breathing.

The plastic bottle represents the chest cavity, and the balloons inside mimic the lungs. A wide straw pushed through the bottle cap represents the trachea and two narrow straws act as the

bronchi. By pulling the balloon at the bottom of the bottle (this represents the diaphragm moving downward), the balloons expand, simulating inhalation. In contrast, when you push up the bottom (the diaphragm moving upward), the balloons deflate, demonstrating exhalation.

- 1 wide straw
- Adhesive tape
- Sealant

Cost: ca. 5 EUR
Time: 45 minutes

INSTRUCTIONS:

- Step 1: Insert two narrow straws into a wide straw and secure with adhesive tape.
- Step 2: Trim them to fit the size of the bottle they'll go in. Then cut the tails off of two balloons and tape the balloons to the ends of the narrow straws.
- Step 3: Prepare a plastic bottle: make a hole to fit the large straw in the bottle cap, and cut the bottom off the bottle.

- Step 4: Pass the large straw through the hole and seal it in place
- Step 5: Insert the "lungs" through the bottleneck and screw the cap on tightly.

- Step 6: To make the diaphragm, put the structure upside down in a glass and stretch another trimmed balloon over the bottom of the bottle. Observe how the balloons in the bottle inflate and deflate as you push and pull on the diaphragm!

THESE INSTRUCTIONS HAVE BEEN WRITTEN BASED ON THE FOLLOWING YOUTUBE VIDEO:

"DIY Model" by MEL Chemistry
https://youtu.be/fybV8zIGyu8?si=9Hg_Tp1YQ95_Zwp5

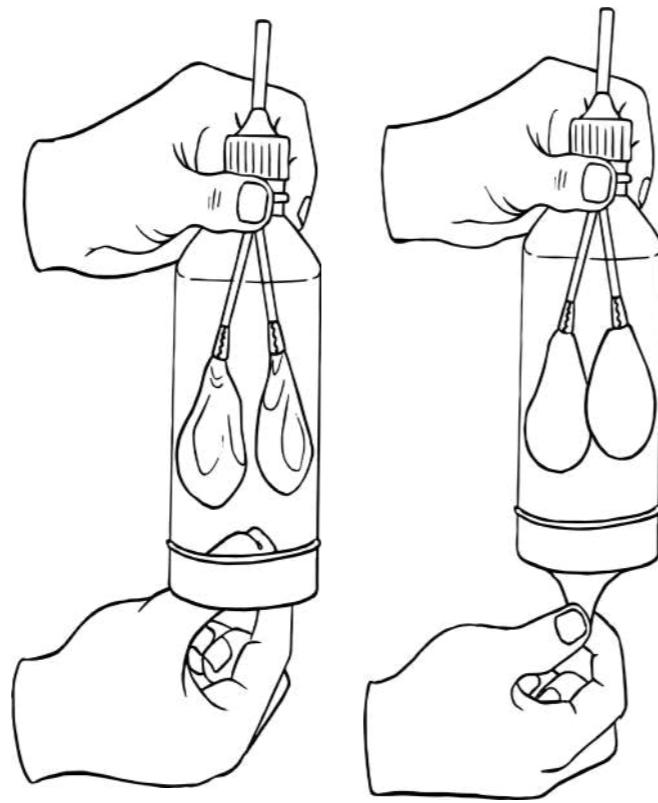

■ Lungs model illustrations by Emma Aitken.

CRANIAL NERVE MODEL

Field: Neurology

LEARNING GOAL:

- Visualize the cranial nerves' connections to the brainstem and their role in sensory and motor functions
 - To understand the anatomical layout of the brainstem and cranial nerves.
 - To understand their topographical location and functional pathways (motor, sensory, mixed).
 - To recognize their topographical relationships.

This model made from

toilet roll tube and colored pipe cleaners offers a hands-on, visual approach to understanding the spatial relationships between the brainstem and the cranial nerves. Each of the 12 colored pipe cleaners represents a cranial nerve, the color indicating whether the nerve is mixed, motor, or sensory. The tube is segmented to represent midbrain, pons, and medulla, and forebrain. After making the holes to correspond to each cranial nerve's location, the pipe cleaners are threaded through the tube, demonstrating the paired nature of the nerves and their anatomical relationships.

■ This text has been written by Giuliana Brancaleone and Nyab Costa.

MATERIALS NEEDED:

- Toilet roll tube
- Pipe cleaners (3 different colors)
- Pen
- Scissors
- (Pin)

Cost: ca. 10 EUR
Time: 30 minutes

INSTRUCTIONS:

- Step 1: Select pipe cleaners in 12 colors, representing each cranial nerve (CN). The colour indicates whether the

CN is: mixed, purely motor or special sensory.

- Step 2: A 1–2 cm strip is cut from the back of the toilet roll tube, before laying it flat. Segment the tube with drawn horizontal lines, representing the parts of the brainstem: midbrain, pons and medulla. A small section at the very top represents part of the forebrain (this can be shaded to indicate clearly that this is not part of the brainstem).

- Step 3: Mark with dots the topographical relationship of the 12 paired cranial nerves

to each "segment" of the tube. Attention is given to key relational features of the cranial nerves to the various parts of the brainstem.

- Step 4: Using a sharp instrument (e.g. a pin), holes are punctured through each pencilled dot (the tip of a pencil can help widen the hole further).

- Step 5: Each cranial nerve (pipe cleaner) is then threaded through the relevant holes in the forebrain and brainstem levels. Both ends of the pipe cleaner are passed through the holes to represent the paired

cranial nerve.

- Step 6: The model is complete once all cranial nerves have been threaded through the tube. They can be cut and shortened further, if necessary, labels added and the model placed upright bending the tube slightly to return its natural curvature

THESE INSTRUCTIONS HAVE BEEN PARAPHRASED FROM THE FOLLOWING ARTICLE:

Quinn, L. (2022). A crafty approach for learning the topographical anatomy of the cranial nerves. *Medical Science Educator*, 32(2), 279- 281.

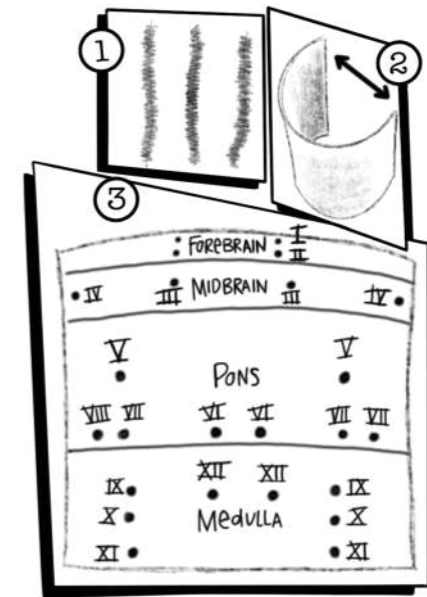

■ Illustration by Giuliana Brancaleone.

KNEE MODEL

Field: Orthopaedics

LEARNING GOAL:

- Understand the structure of the knee joint.
- Visualize how the ligaments and tendons contribute to joint stability and movement.
- Visualize the knee movements.
- Visualize the joint mechanics.

This model serves as a visualization tool to understand the detailed anatomy and biomechanics of the knee joint.

MATERIALS NEEDED:

- Clay
- Pool nuddle
- White Caulking

- Rubber gloves 2 colors
- Screws
- Balloons
- Drill
- Glue
- Tape

Cost: 35-50 EUR
Time: 1-2 days (to allow for drying time of the materials in between steps)

INSTRUCTIONS:

- Step 1: Create the bone models (Femur, Tibia, Fibula, and Patella)
 - Cut the pool noodle to about 10 & 15 cm in length to serve as the core for the femur and tibia parts of the knee model
 - Femur (Thigh Bone)

clay and shape it to match the form of the femur.

- Tibia (Shin Bone) Take the shorter pool noodle cover it with clay to form the tibia's shape
- Fibula Roll a smaller piece of clay (about 7-10 cm long and 1-1.5 cm thick) to represent the fibula, it should be thinner and sit alongside the tibia.
- Patella (Knee Cap) Shape a small oval piece of clay to represent the patella, about 2-3 cm in length.

- Step 2: Apply articulating cartilage with white caulking to the joint surface on the femur.

- Step 3: Cut two small pieces of the pool noodle, to represent the medial and lateral menisci (crescent shapes). Attach Tibia

- Step 4: Attach the Balloons for anatomical details
 - Medial and Lateral Condyles (Femur and Tibia):

- Size: Cut two small blue balloons (about 2 cm wide) to represent the medial and lateral femoral condyles. Attach them to the posterior side of the femur, at the joint area.

- On the posterior side of the femur there are the medial and lateral condyle, represented with an orange balloon cutout (2 cm wide).
 - Tibia: Cut two small blue balloons (about 2 cm wide) and attach them to the medial and lateral aspects of the tibia.
 - Tibial Tuberosity and Tibial Crest: Cut a small purple balloon around 2 cm. Attach it to the front of the tibia.
 - Tibial Crest: Cut an orange balloon, about 6 cm long, and attach it along the front of the tibia to represent the tibial crest.
- Drill small holes (about 1–2 cm deep) through both the femur and tibia at the knee joint.
 - Insert the screws into the holes so that both the femur and tibia can pivot around these screws, simulating the knee joint's pivot point.
- Step 6: Add the Ligaments Using Rubber Gloves
 - Interior Cruciate Ligament (ACL/PCL):
 - ACL: Use a thumb from a clear or white rubber glove to represent the PCL (posterior cruciate ligament), twisting it and screwing it into the posterior part of the knee model.
 - Medial Collateral Ligament (MCL):
 - Cut a piece of a blue rubber glove to

- represent the medial collateral ligament (MCL), and attach it to the medial side of the knee joint.
- Lateral Collateral Ligament (LCL):
 - Cut a piece of a pink rubber glove to represent the lateral collateral ligament (LCL), and attach it to the lateral side of the knee joint.
- Patella Tendon (Green) and Quadriceps Tendon (Yellow):
 - Patella Tendon (Green): Use a green balloon (about 4–5 cm long) to represent the patella tendon, attaching it from the bottom of the patella to the tibia.
 - Quadriceps Tendon (Yellow): Use a yellow balloon (about 4–5 cm long) to represent the quadriceps tendon,

THESE INSTRUCTIONS HAVE BEEN WRITTEN BASED ON THE FOLLOWING YOUTUBE VIDEO:

“Knee Model Construction” by Mariana Carson <https://youtu.be/z5UWQPLN3Vc?si=LVeRxIYM-2Q8o9zdn>

WORKING KIDNEY MODEL

Field: Nephrology

LEARNING GOAL:

- This model is intended to teach students about anatomy of the kidneys and how they work.
- This model visually shows how liquid travels through the kidneys to the bladder, helping to understand basic kidney function and urine formation.

MATERIALS NEEDED:

- Cardboard
- Color Papers or paint
- Threads
- Pipe-like material (e.g. straws)
- Glue Gun
- Glue sticks
- Scissors
- Fevicol
- Paint
- Paint brushes

Cost: ca. 10 EUR
Time: 30 minutes

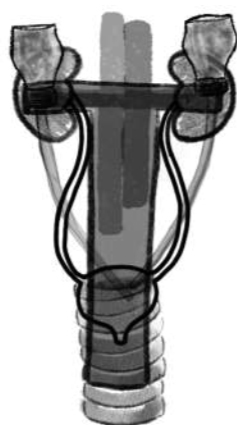

■ Illustration by Giuliana Brancaleone

INSTRUCTIONS:

- Step 1: Draw the form of a kidney on

a cardboard and cut it (left kidney) and do the same for the right kidney.

- Step 2: Draw the same form on red paper (twice), cut it, and glue it onto your kidney cardboards.
- Step 3: Draw 2 cross-shaped forms on cardboard, one slightly bigger than the other.
- Step 4: Draw the same two forms on paper. One on a blue

- paper and the other on a red paper. Cut these and glue the colored paper crosses on the cardboard.
- Step 5: Cut two T-shaped forms from cardboard (bigger than the two cross shaped forms) and glue them together. This will become the stand.
- Step 6: Wrap this stand in red paper.
- Step 7: Draw a round shape with two bended strings (this simulates the bladder) attached on a cardboard as well as on a

- yellow paper. Cut both and glue the yellow paper form on the cardboard.
- Step 8: Cut a rectangle (big) and wrap it in red paper. This will become the socle.
- Step 9: Glue the Red Cross-shaped form right next to the blue one and glue them on top of the T-shaped stand.
- Step 10: Glue the kidneys left and right on the side of the cross shaped forms.

- Step 11: Also glue the yellow forms on the T form, so that the strings that are attached to the round shape below are attached to the kidneys.
- Step 12: Cut the ends of two water bottles (you need the end with the lid) and cut a whole into the middle of each of the lids.
- Step 13: Use the pipe like material, e.g. two straws and stick/ glue them through/to the wholes in the lids.
- Step 14: Attach the water bottle end to the kidney, so, the lids are

- facing down and the straws end at the roundly shaped yellow form.
- Step 15: Put the other end of one water bottle beneath the yellow form, so, the straws end in the water bottle.

THESE INSTRUCTIONS HAVE BEEN WRITTEN BASED ON THE FOLLOWING YOUTUBE VIDEO:

Craftpillar “Kidney working model (3d) with stand for science fair exhibition - Urinary system” <https://youtu.be/WvovXIb0gCs?si=TE5MpUnsfxPb-r-f>

EAR MODEL

Field: Anatomy, Otolaryngology

Make this model to teach/learn the anatomy of the human ear and the functions of its various parts. This model represents the outer, middle and inner ear, with specifically the 3D self-made eardrum from the middle ear and the cochlea in the inner ear.

materials that you find around your house. For the cardboard, you can use any foldable boxes, and for the air drying clay, you can use other materials like plaster, modeling clay or plasticine. As the skin color is painted on the cardboard, you can use any skin tone to make the model as inclusive as possible.

Cost: 5 USD
Time: 1-2 hours

MATERIALS NEEDED:

- Any cardboard sheets
- Empty snack box (optional, to have a stand for the presentation)
- Paper tissue
- White glue
- Acrylic paint
- Brushes
- Air drying clay
- Hot glue gun

INSTRUCTIONS:

- Follow the instruction guide. First make the ear model base with cardboard, then the cochlea and eardrum in air drying clay, and finally the display box to position the model.
- Step 1: Print the model layout (with the inner and outer ear shapes)

- Step 2: Cut the shapes and trace them on the cardboard (follow the quantities indicated)
- Step 3: Cut all the pieces
- Step 4: First make the outer ear by glueing together all the pieces of the outer ear section, and then make the inner ear part by layering and glueing the larger pieces together.
- Step 5: Then, using the white glue mixed with water and the brush, paste the paper tissue all around the outer and inner ear parts.
- Step 6: Using the acrylic paints, paint both ear parts by following the model as color guide (using any skin tone, yellow,

- pink, red, white and black dots).
- Step 7: Glue the outer ear onto the inner ear part.
- Step 8: Make the eardrum and cochlea using air-drying clay. Follow the pictures below to model the right shapes.
- Step 9: Insert the eardrum and cochlea into the inner ear model (where positioned on the model), and let it dry.
- Optional: Step 10: Take the empty snack box, paint it in any color you prefer, and glue the ear model on top of it to make a display box.

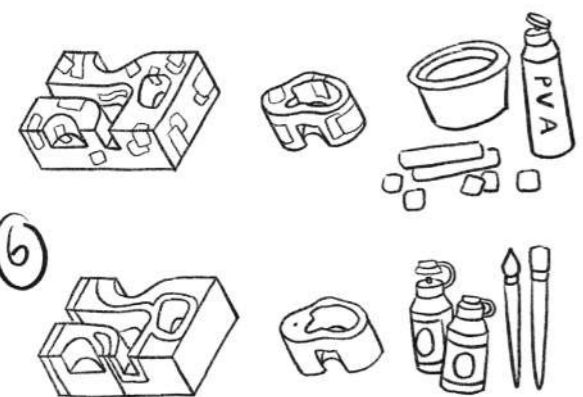
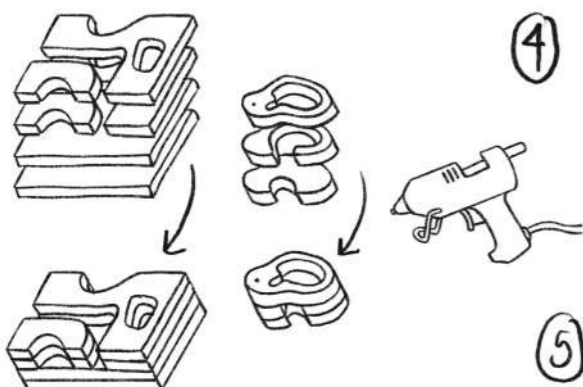
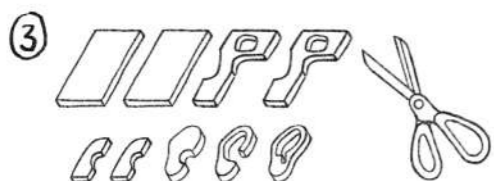
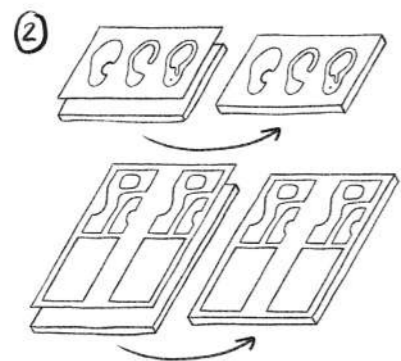
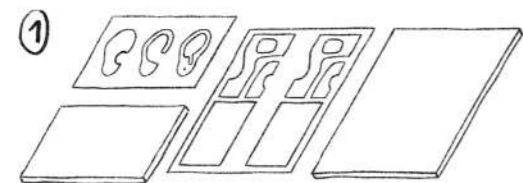

THESE INSTRUCTIONS WERE PARAPHRASED FROM THIS FOLLOWING ENTRY:

Nicekazi on Instructables (Step by Step How to Make 3d Human Ear Anatomy Model/Diagram : 5 Steps - Instructables

3D Ear Layout: Redrawn by Giuliana Brancaleone. Adapted from the following Layout link: DIY Project by nicekazi : Step by step how to make 3D Human Ear Model Anatomy:STEM kids school project

SEE ALSO IMAGES P.39

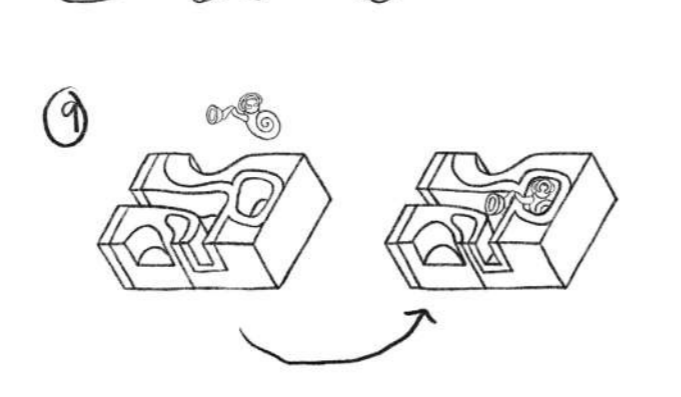
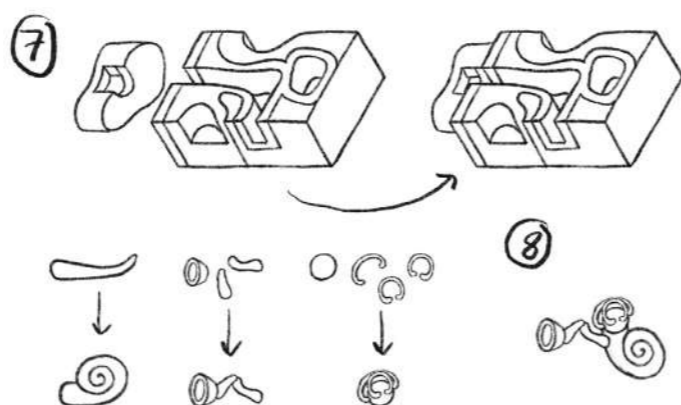

ESSAYS — A NEW WAY OF TEACHING AND LEARNING IN MEDICAL EDUCATION

[Essays]

This catalogue has been informed by a lot of different kinds of research by students, anthropologists, historians, educators and more. It has built from ethnographic studies and from the expertise of teachers at Maastricht University. But mostly this catalogue comes from students who took part in a course studying DIY in medical education, two of these writing the following essays.

A NEW WAY OF TEACHING/ LEARNING IN MEDICAL EDUCATION

As multiple sources showcase (Hallam, 2020; Bell & Evans, 2014; Harris, 2021), there are several ways to teach and learn in the field of medical education. Students need to acquire not only observational but also sensory skills. In this light, medical teachers could use various teaching strategies, one of which is making and using medical DIY models, which enhance the medical curriculum to embody knowledge. As the anthropologist Elizabeth Hallam (2020) noted, ‘designing [DIY models] [...] has the primary aim not of producing tangible products, but of enabling anatomical knowledge to be appropriately and effectively taught and learned (p.104). This can be achieved by exploring different textures and materials and how ‘bodies can be crafted through sensory analogies’, thereby inviting the use of our senses in the medical classroom (Harris, 2021, p.17). This indicates that the body is a tool that needs to be trained in various ways to acquire these skills. The main purpose of designing and creating self-made and/ or homemade objects in medical education, also referred to as medical DIY models, has been to find innovative and creative ways to materialise medical knowledge, in order to teach and learn about the human body and its biological processes in a more representative and sensorily accurate manner. Indeed, even when commercial high-fidelity medical models made in plastic are available (although expensive), they also come with limitations and can be considered too static and somewhat superficial, thereby not representing the fluidity and organic nature of the human body. Thus, when greater visualisation or representation is needed, medical teachers create the models themselves. On top of allowing for greater visualisation, DIYs also enable

greater adaptation to different economic contexts and locations. For example, electrical hook-up wires are used to represent the nervous system, banana peels to imitate the human skin, and inflatable balloons to mimic the movements of the lungs. In this way, medical DIY models shift the reliance of medical faculties on commercially made models, and open the door to more affordable, representative and accessible models. This is especially the case for medical faculties with smaller financial means, which often rely on financial donations from the Global North. Overall, these DIY objects allow for better knowledge transmission and local adaptability in the medical education field.

■ *Giuliana Brancaleone and Nyab Costa*

FURTHER READING AND REFERENCES

Bell, L. T., & Evans, D. J. (2014). Art, anatomy, and medicine: Is there a place for art in medical education?. Anatomical sciences education, 7(5), 370-378. <https://doi.org/10.1002/ase.1435>

Hallam, E. (2020). Anatomical design: Making and using three-dimensional models of the human body. In Design Anthropology (pp. 100-116). Routledge. <http://dx.doi.org/10.4324/9781003085195-8>

Harris, A. (2021). On the fabric of the human body in seven text-iles: The multimodality of learning anatomy, Multimodality & Society 1(1): 8-19 <https://journals.sagepub.com/doi/full/10.1177/2634979521992325>



ADVANTAGES OF MAKING DIYs

Making and the use of DIY in medical education have multiple advantages. Indeed, some DIY models allow for greater anatomical visualisation, or better sensory feeling, which overall improves the learning experience of students. As medical DIY objects, rooted in maker and DIY cultures, are usually crafted with easily accessible and more affordable tools and materials, these objects allow for extensive local and contextual adaptability. Moreover, some DIYs permit students to practice their medical skills outside the medical classroom, and, for example, at home (in the context of COVID-19).

IMPROVED LEARNING EXPERIENCE

“DIY models can also be used to visualise better the body’s anatomy, but I have used them mainly to practice skills, especially the medical skills for which the corresponding commercial model was either not available, too expensive or too fragile. In general, 80% to 90% of the medical skills that students have to learn can be practiced on each other. But for the more invasive skills, like inserting needles, injections, and intimate skills in the gynaecology and obstetrics fields, those ones need a model to reproduce the reality for students to practice. And not all commercial models represent that reality in the best way, so we invent alternative DIY models to allow students to practice those skills.”

■ *Marijke Kruitbof (senior medical educator and lecturer from Maastricht University), interviewed by Giuliana Brancaleone and Nyab Costa on the 19th of March 2025.*

DIY MODELS

These models include DIY models used to practice suture training, IUD placement training on the table, arm-mounted intravenous infusion training, and wound care training.

Tran, a medical doctor with a degree in public health and health profession education based in Vietnam, explains that DIY learning materials serve different purposes depending on the context. He notes that models can have two different roles. DIY tools are often used to demonstrate mechanical or scientific principles in general science, such as physics or physiology. The goal there is to help students understand how something works conceptually. But in medical education, the purpose

is different. It is about simulation, not just observation. “It has to feel life-like,” Tran says. The student needs to perform procedures on the material, not just understand how it works in theory. In medical training, hands-on, sensory experience is essential. That makes it more challenging to create DIY objects that can simulate said sensory experience, but also very valuable and effective in medical education, he concludes.

■ *Adapted from an interview with Trung Tran (medical doctor with a degree in public health and health profession education based in Vietnam), conducted by Giuliana Brancaleone and Nyab Costa on the 26th of March 2025.*

CONTEXT-BASED AND MATERIAL ADAPTABILITY

Schlégl et al. (2022) performed a study at the medical school of the University of Pécs (Hungary), to offer DIY alternatives to students to practice suturing skills when studying online, during the COVID-19 pandemic. The teachers initiated using objects available at home to perform sutures on home-made suturing pads. Indeed, the authors identified multiple replacement objects: the suturing needle can be replaced by a sewing needle, the suturing needle holder by a nail clipper, forceps by eyebrows tweezers, and sewing pads by bananas or oranges, as their peel is similar to the human skin. The learning objectives of this DIY model were to support students in learning how to hold the suturing needle, and acquire the suturing techniques with the right direction, motion, movement, tension, and pressure. The authors concluded the study by explaining that all students could find the necessary material easily and that they were satisfied with the performance of this model. This example demonstrates that medical DIY objects offer new possibilities to practice medical skills by using easily available and affordable tools/materials, and adapting to different contexts, like COVID lockdowns (Schlégl et al., 2022).

■ *Nyab Costa*

Tran highlights the lack of adaptability after giving feedback to commercial models. Meaning they tend not to get upgrades “because it costs a lot of money to change the model,” he reasons. This can further lead to overlooking important differences in regional anatomy and context-specific needs. “The anatomy features of each country are very different,” he says, like skin colour, body size, and weight. These variations are often not

reflected in commercial models, which tend to follow a one-size-fits-all approach. This is where Tran sees a strong advantage in DIY models: they can be adapted more easily to reflect local realities and user feedback. Unlike commercial models, DIY tools can be modified over time, repaired if needed, and tailored to better match the physical, cultural and resource context in which they are used.

■ Adapted from an interview with Trung Tran, conducted by Giuliana Brancaleone and Nyah Costa on the 26th of March 2025.

RESOURCE-LIMITED SETTINGS

“Insufficient investment for skills labs in a developing country is understandable and stands in contrast with the often strong investments in developed countries. Stark and Fortune (2003) suggested that in a first phase of setting up a skillslab in developing countries, it may be easier to let students continue to learn in the clinical environment. However, Hoat et al. (2008) reported the results of an earlier study on skills learning in Vietnamese medical schools; new graduates from schools that already had a skillslab expressed more confidence about skills they had learned than students from schools without one. One way to overcome resource constraints is to use self-made models; greater availability and relevance as well as lower cost makes such models very useful in a resource-limited setting.” (Tran et al., 2014, p. 247).

“Making DIYs in medical education also demonstrates challenges. It requires extensive material research to make sure that the specific materials used will work for the DIY to be made and that they will resemble the body structure that is being created. For example, finding the right materials that will most resemble your skin, either visually or to the touch, and in the best case, both.”

PHD STUDENT IN ANTHROPOLOGY BASED IN SOUTH AFRICA, INTERVIEWED BY NYAH COSTA ON THE 20TH OF MARCH 2025.

FURTHER READING AND REFERENCES

Tran, T. Q., Scherpbier, A., Van Dalen, J., Van Do, D., & Wright, E. P. (2014). Implementing a skillslab training program in a developing country. *Education for Health, 27*(3), 243-248.

DIGITAL TRANSFORMATION & COVID-19

The COVID-19 pandemic locked medical students in their homes, which called for creative homemade solutions for students to still practice medical skills within their rooms. From there, suturing skills could be practised with a banana peel, a sewing needle and eyebrow tweezers; and laparoscopic surgery with a shoebox, some small objects, and a webcam tied to a wooden spoon (Schlégl et al., 2022). Indeed, through their study, the authors Schlégl et al. (2022) aimed to create and develop a collection of simple homemade tools (or DIYs), a sophisticated methodology, and a curriculum to make fundamental surgical training widely accessible in emergencies (i.e., a lockdown). Their goal was also to offer an affordable and accessible surgical teaching option for those with no or limited access to sophisticated simulation facilities and equipment. Therefore, thanks to COVID-19, the authors developed the idea of employing inexpensive educational resources to allow students to practice their medical skills outside of the classroom, thereby creating DIYs. And it was successful! As a result, it could be expanded upon to other nations with little financial resources for medical education. It is notable that following the COVID-19 pandemic, research into various teaching strategies and the maker movement in healthcare exploded. However, it also implies that DIY models are a necessary evil rather than the preferred form of instruction, which demonstrates how DIY models are generally viewed as inferior compared to high-fidelity, commercially made models.

■ Nyah Costa

FURTHER READING AND REFERENCES

Schlégl, Á. T., Pintér, Z. B., Kovács, A., Koppjár, E., Varga, P., Kardos, D., ... & Füzesi, Z. (2022). Distance education for basic surgical skills using homemade tools—diy methods for emergency situations. *Sustainability, 14*(14), 8639, 1-14. <https://doi.org/10.3390/su14148639>

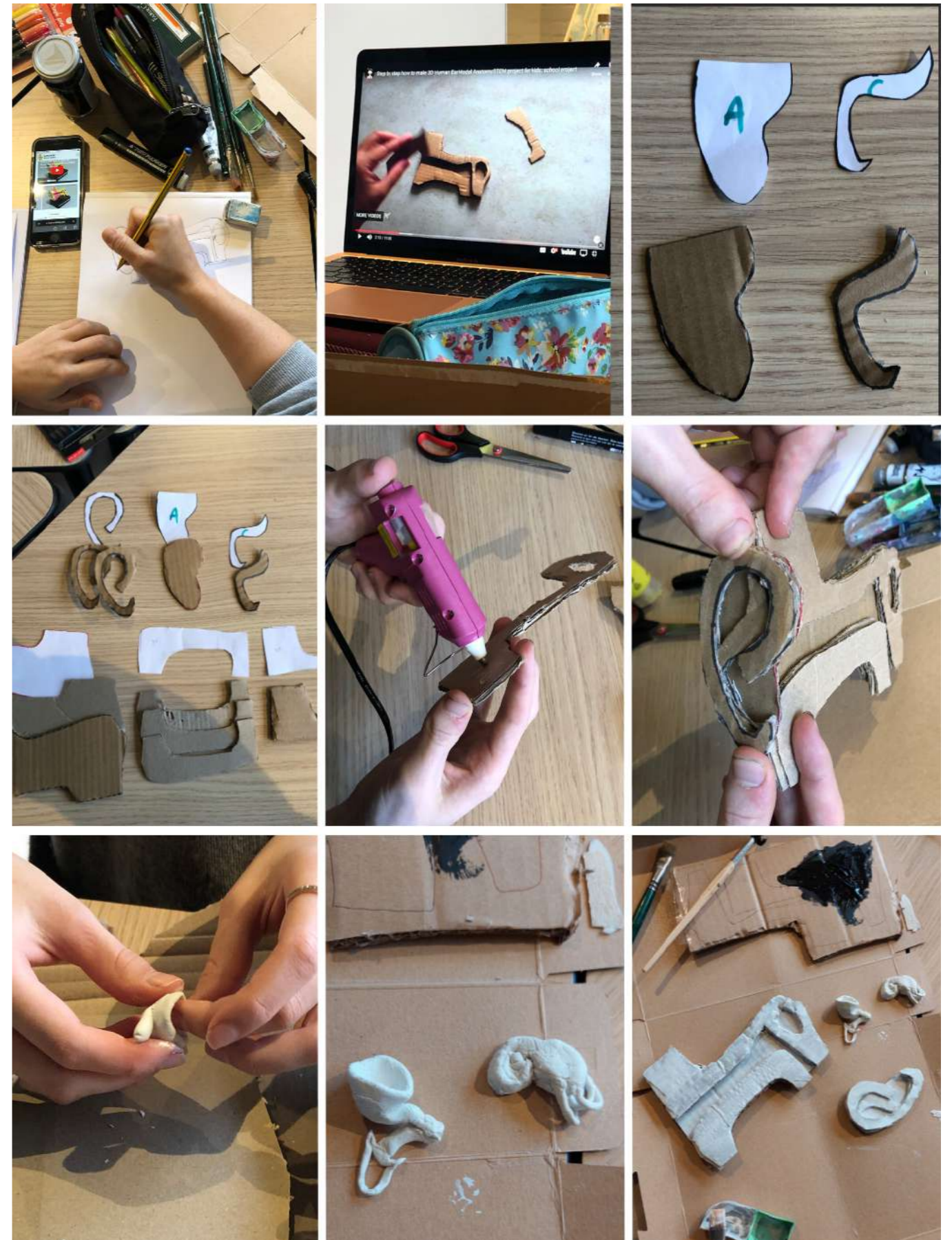

DIFFERENCES BETWEEN THE MANNEQUINS AND THE DIY MODELS

MAINTENANCE, REPAIR - DO YOU DARE OR NOT CARE - TOUCHING COMMERCIAL MODELS

Elizabeth Luchacha, a trained nurse, SkillsLab manager, and teacher at the North Coast Medical Training College in Kilifi (Kenya), further highlights the clear difference between using mannequins and using DIY objects for teaching. “Yes, there’s a difference - a big difference,” she says. With DIY objects, students often find it easier to learn because they are already familiar with the materials, as these are adapted to their local contexts. This familiarity helps them understand the skills more quickly. In contrast, mannequins require more care and come with certain limitations. “There are a lot of precautions with mannequins,” which can make students hesitant or restrict how freely they can practice, she argues.

■ *Adapted from an interview with Elizabeth Luchacha (trained nurse and Skillslab manager at the North Coast Medical Training College in Kilifi, Kenya), conducted by Giuliana Brancaleone and Nyab Costa on the 13th of March 2025.*

“One of the biggest problems of commercial models, and especially, of the cheap models that come from China, is that they very often look “okay” but the materials are so hard that if you would try to do an injection on one of those arms or try to do an internal vaginal exam, then it would not feel the way that the body feels like in reality. So, when students need to practice a medical skill, making DIY models is very useful because they allow for a better sensory feeling. These DIY models are also much cheaper to make. In a lot of the places where I have worked, the funds for the SkillsLabs were limited. So, making alternative models with locally available materials increases the student-to-model ratio, and students can focus on practicing and touching models that mirror the body’s texture better, without risking breaking an expensive model. Even when the DIY breaks, because you were able to make it the first time, you can easily make another one. Whereas for commercial models, there is often no way to repair them, even through the original producer, and those models also require much more maintenance.”

■ *Marijke Kruitbof, interviewed by Giuliana Brancaleone and Nyab Costa, on the 19th of March 2025.*

Luchacha notes that mannequins are a vital part of the skills lab, but also gives additional context to their limitations. “Yes, the mannequins are important, but they are very expensive,” she says. Because of this, they try to use them carefully and extend their life as much as possible. When parts of a mannequin get torn or damaged, they do their best to repair them using glue. “We try to repair them using glue... to bring them back into position and prevent further damage.” To manage costs, they avoid buying multiple mannequins. Instead, they get multipurpose models that can be used to teach several skills. “We buy just one, and then it will work for so many skills,” Luchacha explains. For example, one mannequin might be used for nasogastric tube feeding, male and female catheterisation, IV fluid administration, and intramuscular injections. However, Luchacha highlights that maintenance is a challenge. If a commercial mannequin is seriously damaged, replacing it is difficult. That is why they closely monitor how students use them and act quickly if any damage occurs. “We recheck the students, the way they use (the mannequins), and if there are some spoilers, we repair them immediately.” While mannequins are useful, the simplicity of the DIY objects often makes them more effective for certain learning situations. Students can handle them more easily and feel more confident while practicing on self-made models.

■ *Adapted from an interview with Elizabeth Luchacha, conducted by Giuliana Brancaleone and Nyab Costa on the 13th of March 2025.*

DANGEROUS MODELS

“There is also one commercial model that is used to practice how to insert a subclavicular catheter. If you practice on that one model, you need to insert the needle perpendicularly to the clavicle to get it into the vein. But in reality, when you do it on an actual person, if you did it that way, you could puncture the patient’s lung. So, not only is that not a good model to practice on, but it is also a dangerous one, because it teaches students to do a skill in the wrong way. A colleague of mine in Maastricht University used a piece of chicken breast to insert the catheter, and this was much more realistic than the other expensive model. It is a pity because the need to waste the piece of chicken, but it is a more realistic training tool for students.”

■ *Marijke Kruitbof, interviewed by Giuliana Brancaleone and Nyab Costa, on the 19th of March 2025.*

In stark contrast, during a visit to the Skillslab of the Faculty of Health, Medicine, and Life Sciences of Maastricht University, we briefly interviewed a couple of medical students. It became evident that the students showed little to no concern about the cost of these commercially made models. More so, they demonstrated their trust in the university’s realistic-looking models. Hence, their trust in models seemed related to models looking human-like, rather than their functions or their sensory representation.

■ *Giuliana Brancaleone and Nyab Costa.*

BLUR THE LINE

When talking about training models, it is easy to think of them as either commercial or DIY. However, the models Tran creates fall somewhere between. As Kruitbof explains, referring to Tran’s models: “The kind of models that you are making are going towards the side of the commercial models, but then they are being produced in a more cost-efficient way.” These models aim to offer a similar level of quality and functionality as commercial ones, but without the high price tag attached by large companies focused on profit. This approach makes the models more accessible while still being produced or made for educators, bridging the gap between DIY tools and expensive commercial alternatives.

“But that is where I think your models are so special Trung Tran, because they are high quality. We have shown that they are effective in enabling skills training for students. We just need to multiply and get them out there for other students to use.”

■ *Adapted and quoted from an interview with Trung Tran and Marijke Kruitbof, interviewed by Giuliana Brancaleone and Nyab Costa, on the 19th of March 2025.*

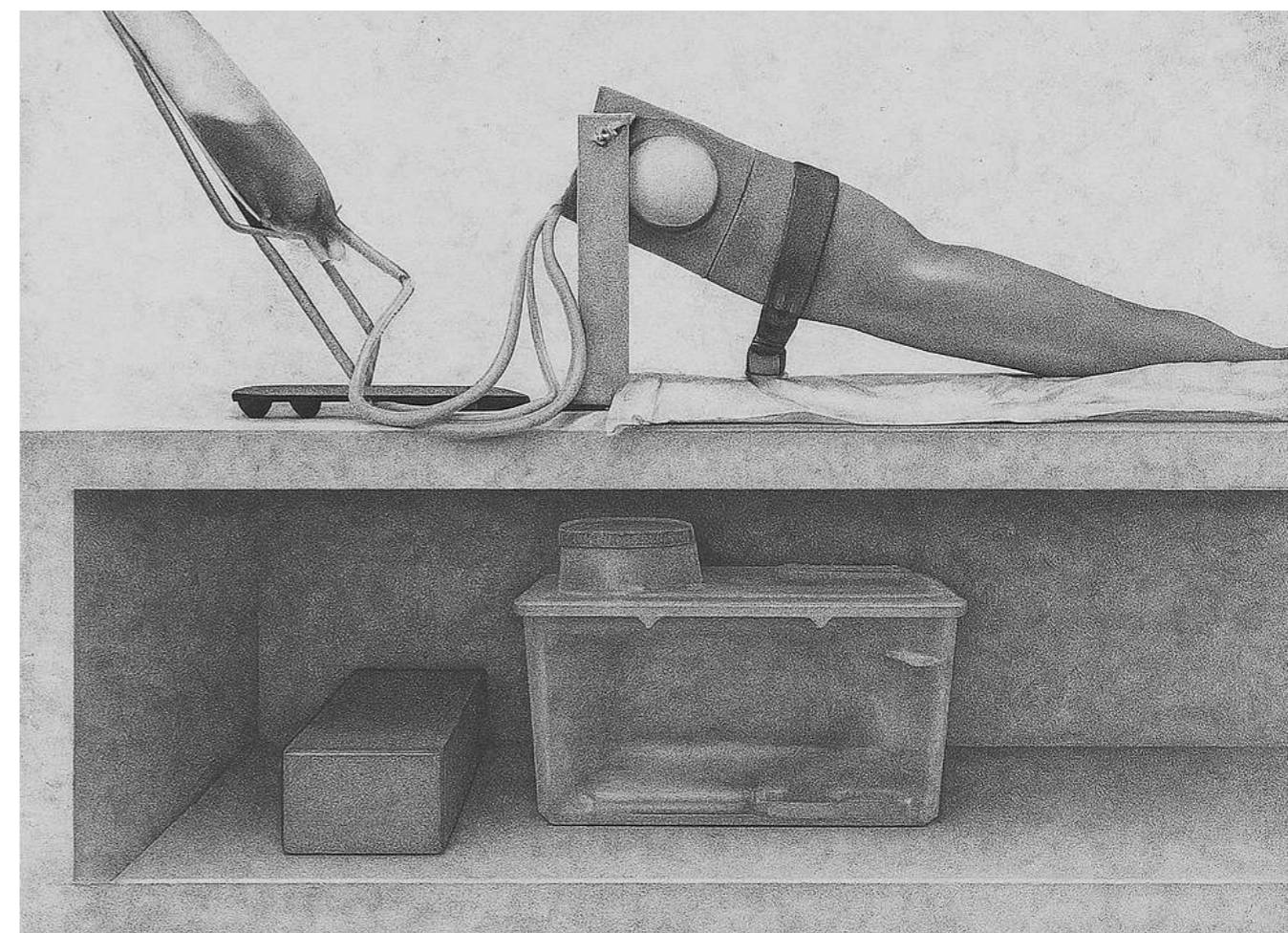

CHALLENGES OF MAKING IN MEDICAL EDUCATION

MISCONCEPTIONS OF DIYS AND NEGATIVE PERCEPTIONS

“Unfortunately, when you try to raise awareness about the use of DIY in medical education, people very often feel like you are trying to sell something that is cheaper, less fancy. To me, it is not a matter of having fancy materials to practice on; it is about reproducing the feeling of the body in the most realistic way, and if commercial models are not accurate, then we need alternative ideas for students to learn on realistic models. Some Universities can afford a 65,000\$ midwifery model, but then, when that one gets donated to a skillslab in Sierra Leone, nobody dares to touch it for fear of breaking it. So what is the point then? If you have fancy models to show but not for your students to practice on, it is not improving medical education.”

■ *Marijke Kruitbof, interviewed by Giuliana Brancaleone and Nyab Costa, on the 19th of March 2025.*

At first, many are sceptical, “Nobody believes about it,” Tran recalls. He trusts that once people can see that DIY models can be done well and in an affordable way, attitudes will change. “If people believe that it is easy [to make medical DIYS], then we can motivate someone in each university to do something.” With the right structure in place, funding, motivated educators, and a strong network, DIY’s could become more popular and succeed. Accordingly, Tran shares what he learned while researching for his article “Teacher-made models, the answer for medical skills training in developing countries?” (reference below). During that research, Tran noticed that interest in DIY models exists in many places. However, in many cases, DIY tools are just made for an exhibit rather than used as a practical teaching tool. He further observed that sometimes, teachers were pressured into making DIYS. In his article, Tran compared teacher-made models (TM) with commercial models (CM) for training students’ basic IV skills. The study took place in the largest health university in Vietnam. Both types of models led to significant improvements in students’ test scores from pre- to post-training, and there was no major difference in overall performance between students trained on TM or CM. However, students who practiced on teacher-made models showed better communication skills with patients than those trained on commercial models.

■ *Adapted from an interview with Trung Tran, conducted by Giuliana Brancaleone and Nyab Costa on the 26th of March 2025.*

Tran et al. 2012 conclude that teacher-made models are a cost-effective and practical alternative to commercial models. They deliver similar training outcomes and can be made using local, affordable materials, making them particularly valuable in low-resource settings where investment in expensive simulation tools is limited.

FURTHER READING AND REFERENCES

Tran, T. Q., Scherpbier, A., Van Dalen, J., & Wright, P. E. (2012). Teacher-made models: the answer for medical skills training in developing countries?. *BMC medical education*, 12, 1-6.

LACK OF FUNDING FOR MAKERS IN MEDICINE

“In recent years, skills labs have been established in many countries. However, because limited resources and experience will affect the choices made by each university regarding skillslab teaching, challenges will arise in training all students to the level required for graduating doctors. Skills Labs vary in their accommodations and resources available, ranging from one room with one manikin to purpose-built structures with a vast assortment of equipment. For developing countries, fully equipped skills labs are expensive to set up and to maintain.” (Tran et al., 2014, pp. 243-244).

FURTHER READING AND REFERENCES

Tran, T. Q., Scherpbier, A., Van Dalen, J., Van Do, D., & Wright, E. P. (2014). *Implementing a skillslab training program in a developing country. Education for Health*, 27(3), 243-248.

While DIY models are affordable, they often lack institutional support and funding. In some cases, decision-makers prefer commercial models because they can gain financial or professional benefits through partnerships with companies, creating a system where cost-effective DIY solutions are overlooked, not due to quality, but due to misaligned incentives and limited funding. “You can see that in some places, people would rather buy commercial models than invest in DIY models, because they can earn some benefit from the commercial company. Even though the DIY is a very low price, they could not earn anything.”

■ *Marijke Kruitbof, interviewed by Giuliana Brancaleone and Nyab Costa on the 19th of March 2025.*

Kruitbof shared an example from her work in Sierra Leone. “They have very expensive gynaecology delivery models that cost 65,000 USD each,” she notes. There were donations from an American university, so there was no cost to the local institution. But the result was the same, the models were rarely used. “If instead of this model that is never used, they could have had like 10 simple models for the same amount of money, it would have been much, much better and more useful for training purposes,” she added.

■ *Adapted from an interview with Marijke Kruitbof, conducted by Giuliana Brancaleone and Nyab Costa, on the 19th of March 2025.*

Tran explains that creating DIY training models is a time-consuming task for many educators and not something everyone finds easy to take on. “Making the model is not easy for every teacher,” he says. In Vietnam, a common concern is “who will cover the cost?” Making educational models takes a lot of time and energy, and there is uncertainty about what they will gain in return. That is why Tran believes a reward system is essential to motivate educators. He suggests that creating new DIY models should be recognised similarly to research. “You can consider a DIY project like a research project,” he states. If teachers know their effort could lead to academic recognition, it would encourage more of them to get involved. Currently, however, teachers either advance their careers or become professors by focusing on research, or they make DIY models. “I have to do research. But when I make the model, I cannot earn anything,” Tran says. “So we have to think about this gain first.” Tran thereby points out how funding and research priorities can sometimes be misaligned with practical needs in education. An example from his university: “From America they come to our university and ask, ‘We really want to do some research, but we don’t know what to do. Do you have anything you would like to do? Can you suggest something, and then I will do the research?’” At first, this seems like a good opportunity. Tran explains that someone might suggest something practical and achievable, like developing a simple model to train IV insertion. But from there, the process can quickly shift. The original idea grows into something far more complex and expensive. Eventually, it turns into a proposal for an advanced, full-body simulation robot that can do everything. Tran reflects, “Then this has to be 600,000 USD, and then it’s too expensive.” This example illustrates how, instead of supporting practical, affordable solutions like DIY models, research efforts often get redirected toward overly ambitious projects that require large amounts of funding, leaving little support for educators and makers who want to create low-cost tools for actual use in classrooms. Tran highlights a common issue in countries with less financial aid: expensive training models are

sometimes treated more as display items than practical tools for student learning. “Sometimes the university uses the model like a decoration, to show off,” he says. Meanwhile, students rarely get to use it because it is considered too valuable. “A student is supposed to practice on a model worth 100,000 USD, but the university buys or receives just one, and it ends up being unused.”

■ *Adapted from an interview with Trung Tran, conducted by Giuliana Brancaleone and Nyab Costa on the 26th of March 2025.*



NEED FOR A NETWORK OF MEDICAL DIYers

“...we show you our ways, then you show us yours, that always makes some exchanges in knowledge.”

ELIZABETH LUCHACHA, INTERVIEWED BY GIULIANA BRANCALEONE AND NYAH COSTA ON THE 13TH OF MARCH 2025.

“We definitely need a platform to share these DIY initiatives within the field. Right now, I feel like we share resources within our institution, but it is more of an individual institution thing. No one is really sharing what they have or have discovered outside of the institution. If we could have a space to share beyond our institutions, we could all learn from each other.”

■ *PhD student in Anthropology, interviewed by Nyah Costa on the 20th of March 2025.*

“I wouldn’t know how to do the DIY models by myself to learn the skill; that is intimidating.”

MEDICAL STUDENT, MAASTRICHT UNIVERSITY (THE NETHERLANDS), IN APRIL 2023.

One of the major challenges is finding committed individuals to lead these efforts [of making models in medical education and doing the related research]. “First, you have to find someone who really wants to do this research, and then they can be trained, but often, they could not find anyone,” Tran explains. Tran emphasises the importance of collaboration when developing effective training and teaching tools. He describes the vision as a large, interconnected effort that can only succeed if several key elements are in place. At the moment, he describes these as proper funding, strong teacher engagement and responsibility, and a supportive network of institutions. “I think it’s a very big system, and it can only happen when we have a lot of other things in order,” he says. Tran clarifies that the goal is not for every university to create its own models in isolation. Instead, he suggests forming a shared network where institutions and individuals can collaborate, share resources, and support each other’s progress.

■ *Adapted from an interview with Trung Tran, conducted by Giuliana Brancaleone and Nyah Costa on the 26th of March 2025.*

“And then now we would like to have a brand new system, making together, not making yourself, with yourself.”

TRUNG TRAN, INTERVIEWED BY GIULIANA BRANCALEONE AND NYAH COSTA ON THE 26TH OF MARCH 2025.

“Your project is very important because you show people that high-quality DIY can be better [than some expensive commercial models].”

TRUNG TRAN, INTERVIEWED BY GIULIANA BRANCALEONE AND NYAH COSTA ON THE 26TH OF MARCH 2025.



MEDICAL EDUCATION AND (POST) COLONIALISM

The effects of colonization remain prevalent in today’s medical discourse and education (Naidu, 2021). Indeed, Naidu (2021) explained how “global medical education is dominated by a Northern tilt”, where Western medicine is seen as the primary legitimate source of knowledge (2021, p. 739). This leaves other types of medicine and understandings of bodies and health, always present in indigenous cultures but suppressed during colonization, seen as illegitimate and left unknown in modern medical curricula (Naidu, 2021). This is also referred to as “ethical imperialism”, reflecting the attempted imposition of Western medicine, techniques, and values in other regions and cultures of the world (Bleakley et al., 2008, p. 267). Further, considering globalization, these views are conveyed through medical education across the world, especially in developing countries holding a colonial past. This implicit coloniality and knowledge hegemony persists nowadays through the adoption of Western medical curricula in other regions of the world. Additionally, it is reflected through the donations of

medical teaching objects and the funding of research plans from Western countries to developing regions (Naidu, 2021; Rashid & Whitehead, 2022). In addition to Western medical knowledge being considered as universal, the effects of colonization are reproducing disparities and further disadvantaging lower-income regions in accessing quality medical research and education. Bleakley et al. described the “90/10” divide, “where less than 10% of the world’s biomedical research funds are dedicated to addressing problems that are responsible for 90% of the world’s burden of disease”, highlighting the way inequalities are deepened in the medical research context (2008, p. 266). Further, medical students outside of the Western world remain disadvantaged, as they are being taught a medical knowledge made universal that does not always capture their local contexts, therefore not matching the circumstances where they live nor where resources are lacking (Bleakley et al., 2008; Naidu, 2021).

■ *Nyah Costa*

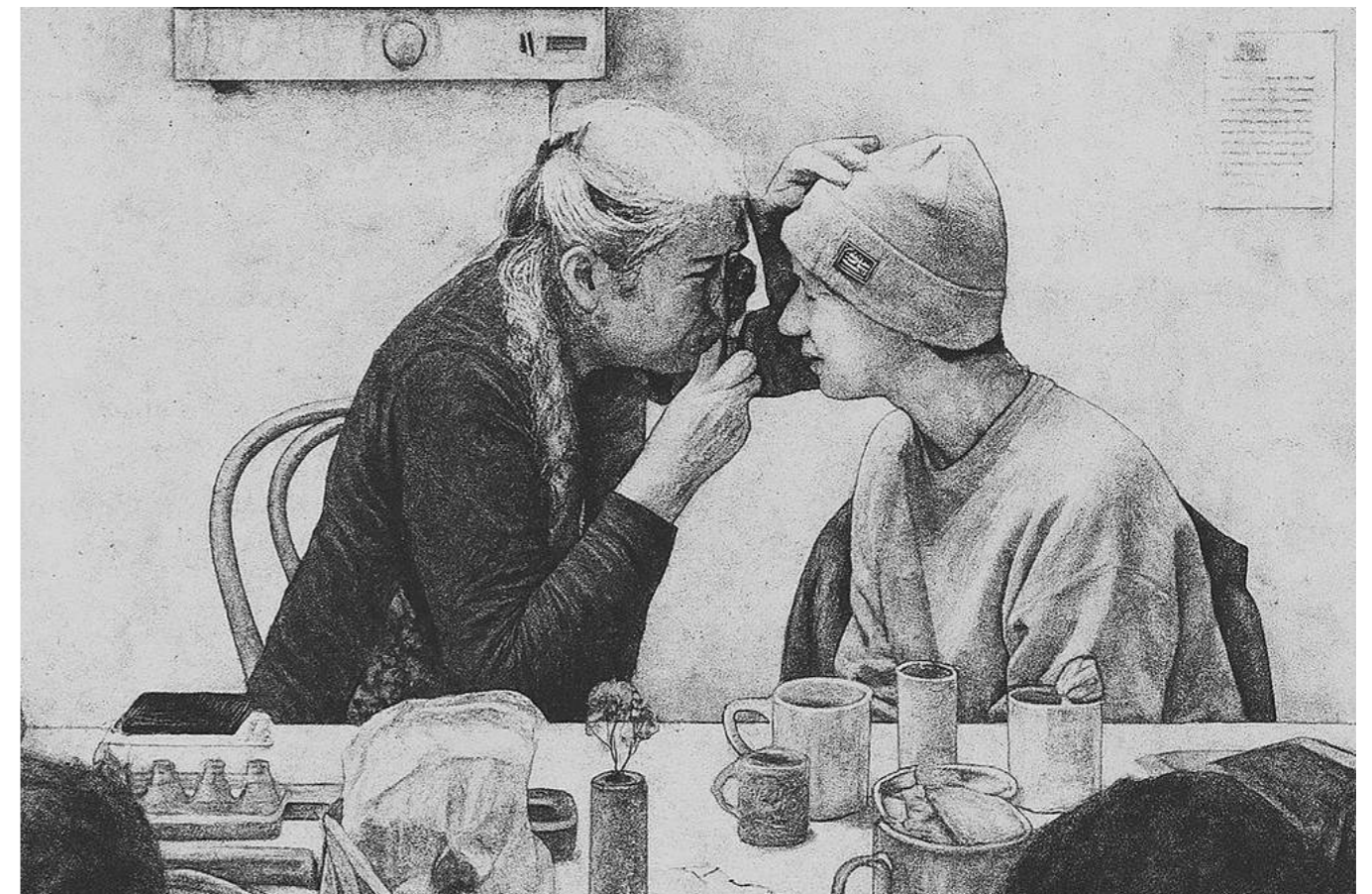

INCLUSIVITY OF BODIES

As students taking a course called DIY in Medical Education, we had the opportunity to visit the Skillslab of the Faculty of Health, Medicine, and Life Sciences of Maastricht University (The Netherlands). The Skillslab seeks to offer instruction on the skills required for a professional doctor-patient encounter to medical students and other healthcare workers. We were allowed to spend an afternoon in the facility to get a better idea of how medical students acquire and develop their expertise.

We started in one of the rooms where students can practice with one another. Following our initial assessment of the space, we opened several cabinets and drawers to examine the various models we discovered inside. They all represented different body parts; from the brain, the spine, to body muscles, hands and skulls. We came across skeletons, an infant model, a knee model, a head model with an androgynous appearance made of Styrofoam, and much more. Further, there were several muscle models that showed the masculine body. It became apparent that most of the models we inspected were white and primarily portrayed the male body. The models in the room displayed masculine features; sharp jawlines, intense body muscles, squared shoulders. By asking another student about the assumption that these models were all representing men, she answered, 'we can see it just with the shape.' There was only one model representing feminine facial features, and we all immediately presumed it was a woman model. It was a handmade DIY face model, with makeup applied; lipstick, foundation, and coloured eyebrows.

This aligns with the research on medical discourse and the dominant role of the male perspective in medical practice that we have read so far. It draws attention to the medical exclusion of the female body in medicine as well as the predominance of white people. Nonetheless, it raises important questions: How does this lack of representation affect medical treatments? And most importantly, to what extent does that put the treatment of women in danger?

Afterwards, the staff showed us the obstetric floor, where we observed the expensive gynaecological models, on which students practice birthing techniques and different auscultations. On the shelf, all the models except one, were made with white-skin leather. Thus only one model was made of dark skin leather. Apparently there were more in the past, but they were damaged by students. On the opposite side of the room, there were the female breast models. The models were all identical, with round, symmetrical and idealized breasts, and still demonstrated a lack of inclusivity

regarding skin colours. In general, all the models in that room represented a white female body with fatless, perfectly round shapes, compliant with the modern Western beauty standards.

Again, the limited inclusivity of bodies raises questions: What ideas about femininity do these models convey to medical students and society as a whole? How does this affect the way doctors view patients who are overweight or have different-colored skin? This prompts us to question the potency of teaching medicine students with a focus on one type of body: the fit white male.

By consulting the students who were studying at the Faculty, it became clear that they did not seem to question the production of knowledge and skill, and their interaction with representation of different bodies. When developing a new method of instructing medical students, it is crucial to consider this issue. It follows that the (re)introduction of DIY-creating tools can help deconstruct the power structures present in medical education, but most importantly, an ongoing reflection about knowledge and power production is required.

Through the research that we have conducted, most DIYs used in medical education tend to find analogies for textures, body parts and features. Thus, they do not portray the human body in the same realistic way that commercial models do, and leave little space for masculine bias. Using balloons, yarn, clay or fruit, the objects presented in this catalogue are carefully selected to promote greater diversity, inclusivity and representation in the medical education field.

■ *Giuliana Brancaleone and Nyah Costa.*



OUTRO



[Outro]

There are many people to thank for making this catalogue possible, including especially all of those educators who have generously shared their inventions with the world, which we have collected and curated here, and our illustrators. In this section you can read our gratitude, as well as find further resources to read, and most exciting of all, templates to cut out for your designs.

CONCLUSION

Many highly valued learning materials for training clinical skills in undergraduate medicine are currently directed by principles of digital innovation and high fidelity. Not only does this entail significant cost, but it also does not recognize more sustainable and locally- relevant solutions. This catalogue aimed to address this problem by collecting, curating and facilitating open sharing of low-cost learning materials for healthcare profession's skills educators. We now invite readers of this catalogue to be inspired, take up scissors, paper and glue, and make their own DIY materials based on the resources reviewed, described, quoted and listed here. We have included templates and patterns to cut out.

■ *Giuliana Brancaleone and Nyah Costa.*



INSIGHTS FROM AN ILLUSTRATION STUDENT

“While working on the illustrations for this project, I found it very fascinating to see that people who are working in academia or the medical field have a lot more creative practices than I imagined. It is exciting to see people participating in their own ways of creative expression outside of the usual ways in education. While doing my own research into the experiment before starting the illustrations, I found that I was learning new things. For example, on the innovation within the medical field, which now uses 3D printed replacements in surgeries.”

■ *Emma Aitken (University of Dundee, Scotland, UK), who produced some of the illustrations for this catalogue.*

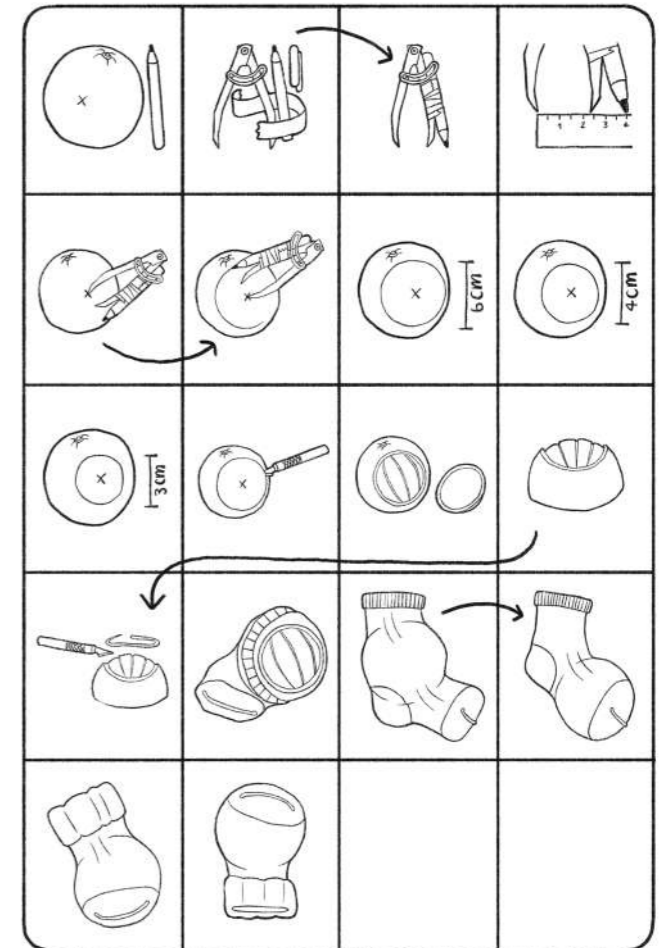

NOTE ABOUT THE CATALOGUE SERIES

We are delighted to officially launch, with this inaugural issue, a series of catalogues we are calling Clinical Tools: A DIY Catalogue for the Creative. Our first issue, EDUCATION, guest edited by Nyah Costa and Giuliana Brancaleone celebrates abundance in medical education.

In the design of the catalogue, which our collaborators Studio Reuring have worked with us on, we deliberately play here with the format of the glossy catalogue selling the latest smart silicon teaching tool to medical schools, often at great expense, and often obsolete, non-degradable, forgotten or broken in less time than we want to think. Instead we celebrate the abundance of already existing materials, offering an open-source investigation of the DIY teaching tools shared by creative medical educators and students around the world, whether in articles or interviews. These are the results of everyday designers of medical learning playfully exploring how to teach the critical clinical skills of sensory learning and anatomical lessons with materials that come to hand.

Resonating with the DIY intentions and aesthetics of publications such as the Whole Earth Catalog, we wanted to make a beautiful publication that encourages others to make do too. The catalogues in this series will always be easy to photocopy, filled with instructions for making, designed to be shared with others, with thoughtful essays to stimulate new ideas and conversations. Stay tuned for Issue #2, due out in 2026!

■ *Anna Harris, Clinical Tools series editor and principal investigator of The Upcycled Clinic.*

CONTRIBUTORS AND ACKNOWLEDGMENTS

This catalogue was edited by Nyah Costa and Giuliana Brancaleone. It contains open-source material, citations from academic articles, quotes from interviews conducted online by Nyah and Giuliana, medical student reviews, illustrations by Emma Aitken and Giuliana, photos and short essays written by Nyah and Giuliana. All material is either in the public domain or used with permission, with citations for further investigation by readers provided whenever possible. The catalogue has been designed by Ruben Machiels from Reuring Studio <https://www.reuring.studio/>, in Maastricht, the Netherlands.

The making of this catalogue was funded by an EDLAB - Education Research Grant from Maastricht University, the Netherlands, "Making together, learning together: A DIY catalogue for health professions education". The grant was awarded to Anna Harris, Marijke Kruithof and Emmaline Brouwer, who also provided supervision of the editing and making of the catalogue, as well as writing, introductions and networks. Anna's time working on the catalogue has also been funded by the European Research Council (Grant No. 101125003). This is the first catalogue "Education" in a series of Clinical Tools catalogues to be made in the context of The Upcycled Clinic project funded by this grant.

Many makers and medical educators from the field shared their precious time and experience. Interviewees included: Marijke Kruithof, a senior medical educator and lecturer from Maastricht University (the Netherlands); Elisabeth Luchacha, a trained nurse and SkillsLab manager at the North Coast Medical Training College in Kilifi (Kenya); Trung Quang Tran, a medical doctor with

a degree in public health and health profession education based in Vietnam; and a PhD student in Anthropology from the University of Pretoria (South Africa). Students from Maastricht University contributed reviews of two of the selected objects presented in this catalogue. Among others, thank you, Lara Heindrichs. Emma Aitken made the beautiful illustrations in the catalogue as part of the "Picture This" pilot project at Maastricht University.

This catalogue draws from a course which explored the use of DIYs in medical education at Maastricht University, as part of the Maastricht Research-Based Learning project (MaRBL) (2022-2023). The latter project was led by Anna Harris, and the group gathered Lia Hruby, Martina Bardelli, Remco Poeliejo, Emily Lake, Giuliana Brancaleone and Nyah Costa. Thank you colleagues, for allowing us to revisit our materials and bringing them further to light.

Many thanks to Studio Reuring for the catalogue layout and design work.

FURTHER READING FROM THIS PROJECT CAN BE FOUND AT:

Harris A, Bardelli M, Brancaleone G, Costa N, Hruby L, Poeliejo R. *Making as Method in Teaching: Do-It-Yourself (DIY) Objects and Hands-on Learning with Materials. Perspectives on Medical Education. 2025; 14 (1): 309-318. DOI: <https://doi.org/10.5334/pme.1575>*



INTERESTING RESOURCES TO DIVE INTO THIS TOPIC FURTHER

- Akaike, M., Fukutomi, M., Nagamune, M., Fujimoto, A., Tsuji, A., Ishida, K., & Iwata, T. (2012). Simulation-based medical education in clinical skills laboratory. *The Journal of Medical Investigation*, 59(1, 2), 28-35.
- Bell, L. T., & Evans, D. J. (2014). Art, anatomy, and medicine: Is there a place for art in medical education?. *Anatomical sciences education*, 7(5), 370-378. <https://doi.org/10.1002/ase.1435>
- Bleakley, A., Brice, J., & Bligh, J. (2008). Thinking the post-colonial in medical education. *Medical Education*, 42(3), 266-270. <https://doi.org/10.1111/j.1365-2923.2007.02991.x>
- Hallam, E. (2020). Anatomical design: Making and using three-dimensional models of the human body. In *Design Anthropology* (pp. 100-116). Routledge. <http://dx.doi.org/10.4324/9781003085195-8>
- Han, S., & Bhattacharya, K. (2001). Constructionism, learning by design, and project based learning. *Emerging perspectives on learning, teaching, and technology*, 127-141.
- Harris, A. (2021). On the fabric of the human body in seven text-iles: The multimodality of learning anatomy. *Multimodality & Society* 1 (1): 8-19 <https://journals.sagepub.com/doi/full/10.1177/2634979521992325>
- Hoat, L. N., Son, N. M., & Wright, E. P. (2008). Perceptions of graduating students from eight medical schools in Vietnam on acquisition of key skills identified by teachers. *BMC Medical Education*, 8, 1-10.
- Jungnickel, K. (2018). Making things to make sense of things: DIY as research and practice. In *The Routledge companion to media studies and digital humanities* (pp. 492-502). Routledge.
- Katzman, J. G., Balbus, J., Herring, D., Bole, A., Buttke, D., & Schramm, P. (2023). Clinician education on climate change and health: virtual learning community models. *The Lancet Planetary Health*, 7(6), e444-e446.
- Naidu, T. (2021). Southern exposure: levelling the Northern tilt in global medical and medical humanities education. *Advances in Health Sciences Education*, 26(2), 739-752. <https://doi.org/10.1007/s10459-020-09976-9>
- Nott, J., & Harris, A. (2020). Sticky models: History as friction in obstetric education. *Medicine Anthropology Theory*,

7(1). <https://doi.org/10.17157/mat.7.1.738>

- Rashid, A., & Whitehead, C. (2022). Applying postcolonial theory in academic medicine. *Journal of the Royal Society of Medicine*, 115(5), 193-194. <https://doi.org/10.1177/01410768221084081>
- Richterich, A. (2020). When open source design is vital: critical making of DIY healthcare equipment during the COVID-19 pandemic. *Health Sociology Review*, 29(2), 158-167. <https://doi.org/10.1080/14461242.2020.1784772>
- Schlégl, Á. T., Pintér, Z. B., Kovács, A., Kopjár, E., Varga, P., Kardos, D., ... & Füzesi, Z. (2022). Distance education for basic surgical skills using homemade tools—diy methods for emergency situations. *Sustainability*, 14(14), 8639, 1-14. <https://doi.org/10.3390/su14148639>
- Shai, A., Koffler, S., & Hashiloni-Dolev, Y. (2021). Feminism, gender medicine and beyond: a feminist analysis of "gender medicine". *International Journal for Equity in Health*, 20(1). <https://doi.org/10.1186/s12939-021-01511-5>
- Stark, P., & Fortune, F. (2003). Teaching clinical skills in developing countries: Are clinical skills centres the answer?. *Education for health*, 16(3), 298-306.
- Tran, T. Q., Scherpbier, A., Van Dalen, J., & Wright, P. E. (2012). Teacher-made models: the answer for medical skills training in developing countries?. *BMC medical education*, 12, 1-6
- Tran, T. Q., Scherpbier, A., Van Dalen, J., Van Do, D., & Wright, E. P. (2014). Implementing a skillslab training program in a developing country. *Education for Health*, 27(3), 243-248.
- Tran, T. Q., Scherpbier, A., Van Dalen, J., & Wright, P. E. (2012). Teacher-made models: the answer for medical skills training in developing countries?. *BMC medical education*, 12, 1-6.
- Vinsel, L., & Russell, A. L. (2020). The innovation delusion: How our obsession with the new has disrupted the work that matters most. *Crown Currency*.
- Wexler, A. (2016). The practices of do-it-yourself brain stimulation: implications for ethical considerations and regulatory proposals. *Journal of medical ethics*, 42(4), 211-215

TOOTH MODEL CUTOUT

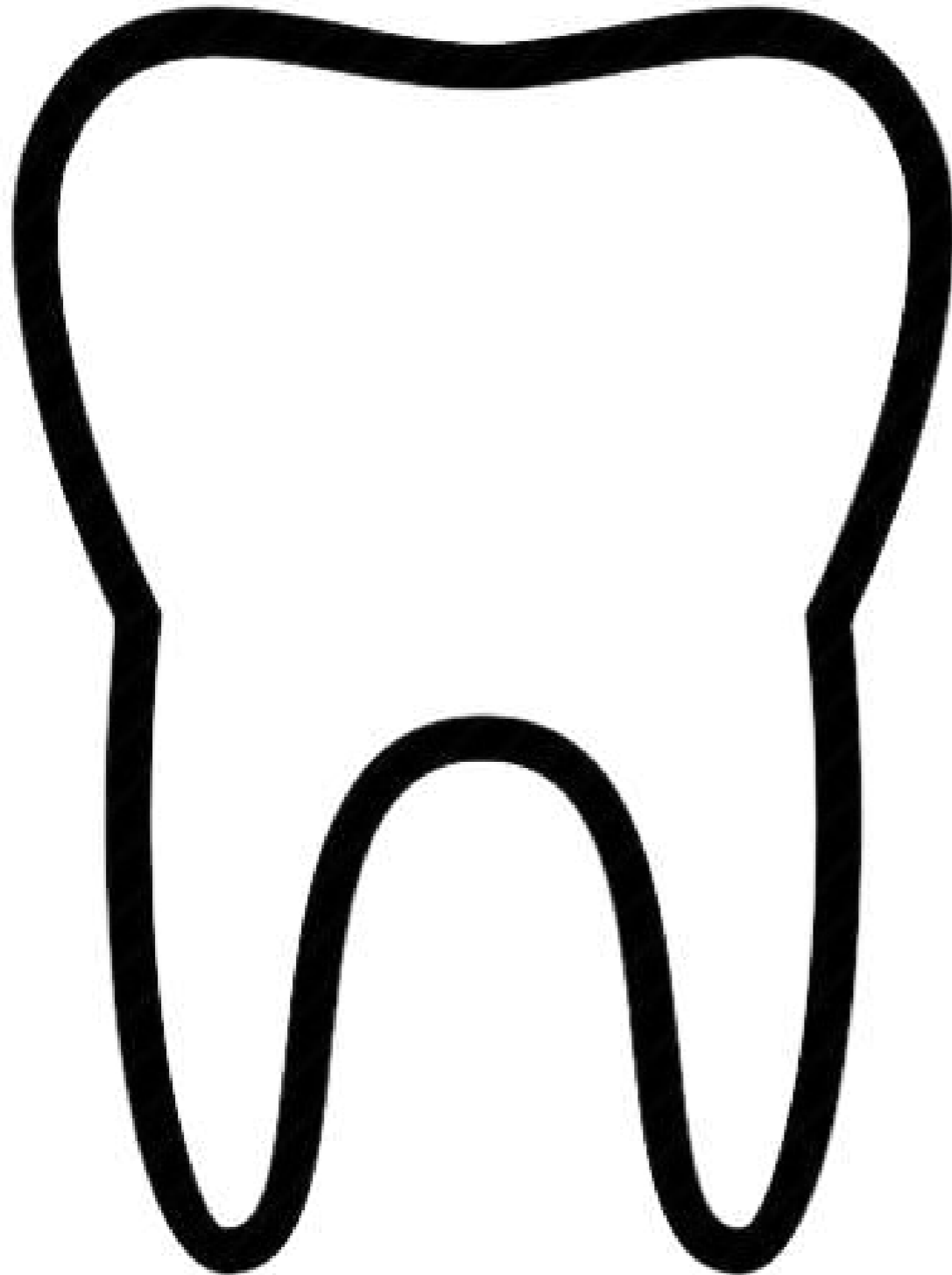

EAR MODEL CUTOUT

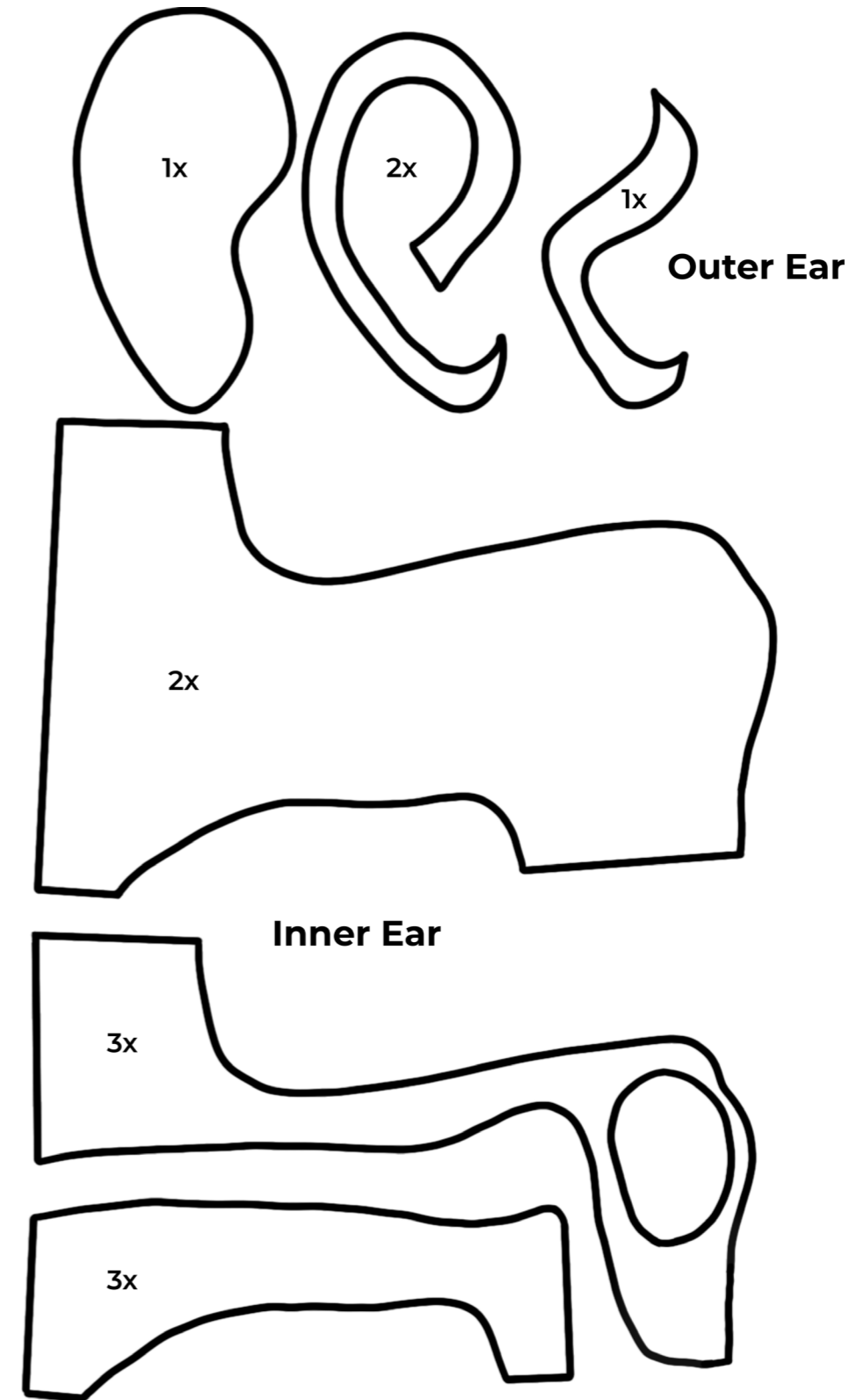

**3
D
E
a
r
A
n
a
t
o
m
y
M
o
d
e
l
L
a
y
o
u
t**

A DIY CATALOGUE FOR THE CREATIVE



Ever considered where your learning tools come from as you study or teach medicine? So many teaching materials in medicine are mass-produced, environmentally unfriendly, and reproduce the same kind of bodies. We need a drastic rethinking of our teaching tools. But rather than new inventions, what if the innovations we need are already out there?

Our first issue of *Clinical Tools: A DIY Catalogue for the Creative* celebrates the abundance of ideas for teaching materials that already exist in medical education. We have made the catalogue easy to photocopy so you can distribute it easily. Inside you will find gorgeous illustrations, clear instructions for how to make tools and insightful essays exploring the ideas behind DIY in medical education. Get your making supplies ready!