

Chisel Scaler HRV-95B

PRODUCT INSTRUCTIONS & SAFETY INFORMATION



**MANUFACTURED
IN SWEDEN**

Warning

Failure to follow the safety warnings and instructions may result in **serious injury**. Remember to save these warnings and instructions for future reference.

Table of Contents

Technical data.....	3
Thank you for choosing a tool from IPT Technologies	3
Intended use.....	4
Important safety notes.....	4
Warnings.....	4
Warranty	4
Instructions for use	5
Maintenance	6
Disposal.....	6
Accessories.....	7
Spare Parts	8

Technical data

Length	210 mm	
Weight	1.45 kg	
Frequency of Strokes	150 Hz	
Length of Strokes	6 mm	
Maximum air Flow	1.5 l/s	
Air Pressure	6-6.5 bar	
Maximum Air Pressure	8 bar	
Maximum Air Temperature	35° C	
Hose Coupling	1/4 inch	
Size of Hose Recommended	6-10 mm	
Vibration Level according to ISO 28927-9	3,5 m/s ²	Uncertainty 0,8 m/s ²
Sound Pressure Level according to ISO 15744	68 dB (A)	Uncertainty 3 dB (A)
Sound Power Level according to ISO 15744	79 dB (A)	Uncertainty 3 dB (A)

Warning. Declared values obtained from lab testing according to standards can help compare tools. However, they are insufficient for accurate risk assessments. Actual exposure and risk of harm depend on additional factors.

Thank you for choosing a tool from IPT

Technologies

The HRV-95B weld flux scaler is an advanced, actively vibration-damped scaler with a very low noise level (System IPT). It weighs less and is less bulky and, therefore, easier to work with than other vibration-damped scalars. Following these simple instructions will ensure a long life of excellent operation.

Intended use

This tool is intended for professional use only. Neither the tool nor its accessories must be modified in any way. If the product or accessories have sustained damage, do not use them. Installation, operation, and servicing should be carried out exclusively by qualified personnel. Safety and adherence to these guidelines are paramount.

This product is designed for scaling, chipping, riveting, or ramming.











Important safety notes

All local safety rules regarding installation, operation, and maintenance shall always be followed. Always use adequate personal protective gear, such as safety goggles, noise protection, gloves, etc., as appropriate.

Always disconnect the tool from the air line before changing the chisel or making other adjustments.

Carefully blow the compressed air hose clean before connecting the tool to ensure there is no accumulation of water or dirt. The compressed air should be dry and clean. A filter unit should always be used.

Warnings

-  Do not exceed 8 bar pressure. Use a regulator set to 6 to 6,5 bars.
-  Power tools are not insulated for encountering electric power sources.
-  Power tools shall not be used in explosive atmospheres.
-  Do not use chisels that are broken, cracked, or deformed.
-  Use only accessories designed for this tool.
-  Stored compressed air may cause a hazard.
-  Long hair or loose clothing may be drawn in or trapped by the power tool.
-  Make sure that any sparks emitted are directed so as not to cause a hazard.
-  Be aware of the risk of a whipping compressed air hose.
-  Use a facemask or respirator if the work creates dust.

Warranty

The HRV-95B Needle Scaler is warranted for 12 months from the date of purchase against faulty workmanship or materials, provided the tool has not been opened by unauthorized

persons and has always been lubricated and connected to a filtered air supply of the recommended pressure.

Please return any defective tool to your authorized supplier.

This warranty does not include repair or replacement required because of misuse, abuse, or normal wear and tear on wear parts.

Use only original IPT spare parts for any replacement. Other parts may result in hazardous conditions, decreased performance, and increased maintenance and wear.

Instructions for use

General Information

The scaler is designed to operate at an air pressure of 6 to 6.5 bar but will tolerate some variations without much change in performance. Do not exceed 8 bar pressure. Use a regulator set to 6.5 bar. Connect to ¼" hose connection.

Ensure there is no accumulation of water or dirt in the hose by carefully blowing the hose clean before connecting the tool. The compressed air should be dry and clean. A filter unit should always be used. In-line lubrication is recommended. Where this is unavailable, apply a generous amount of oil in the air supply hose 2 to 3 m upstream of the tool every 2 to 4 hours of operation. This is considerably more efficient than supplying oil directly to the tool inlet.

Operation

The scaler is designed for weld dressing but is excellent for other duties where "light hammering" is involved, e.g., cleaning of smaller castings, trimming, removal of caulking, removal of rust, insertion of pins, etc. The low vibration level and the fairly short stroke result in much better precision for the work involved.

The scaler should not be used as a crowbar but with a light to medium down push. Let the tool do most of the work itself. Find the best angle to the work surface for smooth operation.

If the compressed air supply to the tool is interrupted, the throttle should be released. When the supply is reestablished, restart the tool.

This tool is low vibration. Stop using the tool if you can feel that the vibration level has increased! Increased vibrations indicate something is wrong, and continued operation might damage or destroy internal parts. The reason for more vibrations can be a damaged housing, a broken spring, or other part. It can also depend on the tool having been pulled apart and then improperly reassembled.

NOTE! Do not clamp the Housing (5) in a vice. Deformation of the housing will result in poor performance and increased vibration.

Blow function

HRV-95B is equipped with a "blow function." It is very simple to operate and is used to blow clean the workpiece whenever desired. During normal operation, the throttle lever is

e. Press the lever further down towards the lower right figure.

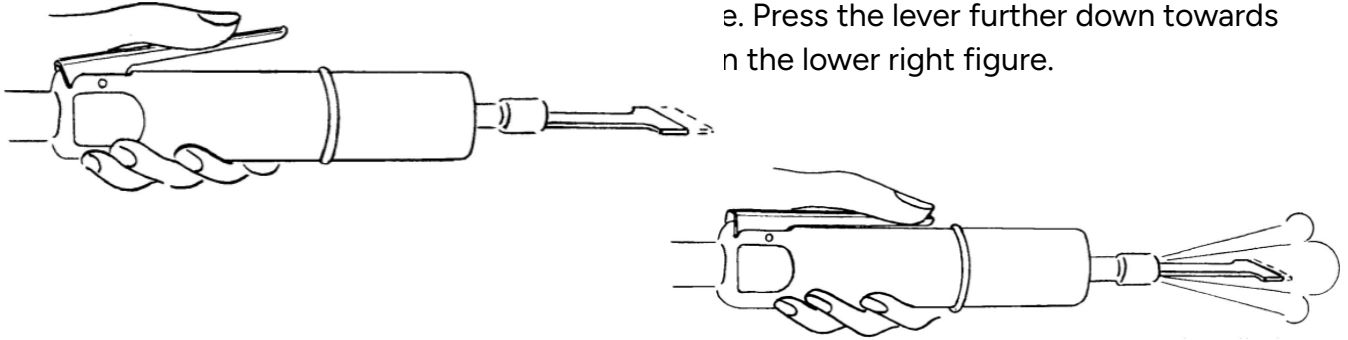

Changing the Chisel

NOTE: Always disconnect the scaler from the compressed air line when removing or attaching chisels. For available chisel sizes, see page 6.

Use a 17 mm wrench to loosen the nut (1). Insert the chisel between the two retainers (3) and retighten the nut firmly. Ensure that the nut and retainers properly clamp the chisel.

Maintenance

Lubricate regularly (apply a generous amount of oil in the air supply hose 2 to 3 m upstream of the tool). Use only quality air tool oil. If a continuous lubrication unit is used, it should be positioned 3 to 5 m upstream of the tool, or it will not be effective. The oil flow should be set to provide one drop of oil for every 150 liters of free air.

Lack of lubrication will result in excessive wear of critical parts inside the tool.

Note: Do not open the tool; it will void the warranty!

Disposal

This tool is designed and manufactured to last a long time if properly maintained, and all parts are available as spare parts. If you want to recycle it for any reason, please dismantle it completely, degrease it, and send the different materials separately for recycling according to local laws and regulations.

Accessories

HRV-95A is delivered without a chisel so that you can choose the optimal one for your job. Chisels are available in different widths, lengths, and materials. See the list below.

The chisels fitted with tungsten carbide are recommended for weld dressing and similar jobs.

There are chisels without carbide available for jobs where a “softer” chisel surface is desired.

Note that other chisels than those available from IPT may have non-optimal properties and/or weights. This can result in significantly higher vibration levels.



Part number	Description	Width (mm)	Length (mm)
H-95-01-10	Chisel with Tungsten carbide tip	10	110
H-95-01-17	Chisel with Tungsten carbide tip	17	100
H-95-01-36	Chisel with Tungsten carbide tip	36	100
H-95-01-53	Chisel with Tungsten carbide tip	53	100
H-95-01-10L	Chisel with Tungsten carbide tip	10	220
H-95-01-17L	Chisel with Tungsten carbide tip	17	220
H-95-01-36L	Chisel with Tungsten carbide tip	36	220
H-95-01-10H	Hardened Chisel without carbide tip	10	110
H-95-01-36H	Hardened Chisel without carbide tip	36	120
H-95-01-53H	Hardened Chisel without carbide tip	53	100

Spare Parts

Use only original IPT spare parts for any replacement! Other parts may result in hazardous conditions, decreased performance, increased wear, and damage to the tool.

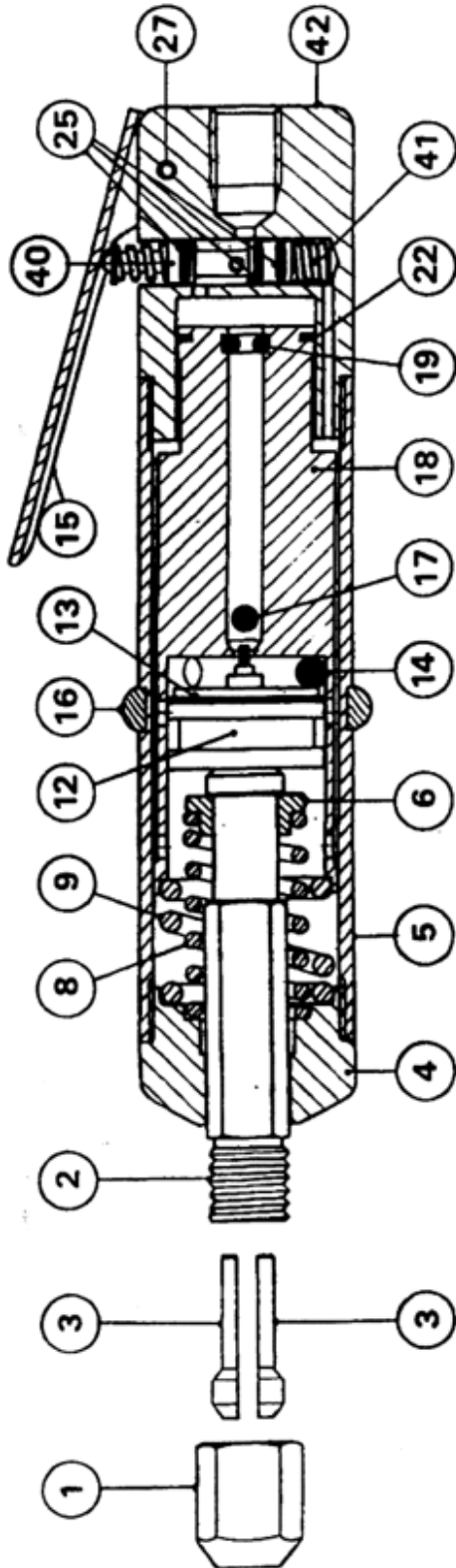

- | | |
|-----------------------------------|------------------------------------|
| 1. H-95-01 Nut | 22. S-100-22 Piston Ring |
| 2. H-95-02 Piston Extension | 25. S-100-25 O-ring (3 pcs needed) |
| 3. H-95-03 Chisel Retainer (pair) | 27. S-100-27 Pin |
| 4. H-90-04 Front | 40. H-95-40 Valve Stem B machine |
| 5. H-90-05A Housing, normal | 41. H-95-41 Valve Spring B machine |
| 6. H-90-06 Support | 42. H-95-42 Rear, B machine |
| 8. S-100-08 Spring | |
| 9. S-100-09 Spring | |
| 12. S-100-12 Piston | |
| 13. S-100-13 Piston Ring | |
| 14. H-90-14 Limit Ring | |
| 15. H-95-15 Throttle | |
| 16. H-90-16 Support Ring | |
| 17. S-100-17 Ball | |
| 18. H-90-18 Cylinder | |
| 19. S-100-19 Retainer | |