

Air Saw SRV-110

PRODUCT INSTRUCTIONS & SAFETY INFORMATION



**MANUFACTURED
IN SWEDEN**

Warning

Failure to follow the safety warnings and instructions may result in **serious injury**. Remember to save these warnings and instructions for future reference.

Table of Contents

Technical data	2
Thank you for choosing a tool from IPT Technologies.....	3
Intended use.....	3
Important safety notes.....	3
Warnings.....	3
Warranty	4
Instructions for use	4
Troubleshooting.....	6
Maintenance	7
Disposal.....	7
Accessories	7
Spare Parts.....	8

Technical data

Length	210 mm
Weight	1.05 kg
Frequency of Strokes	160 Hz
Maximum air Flow	1.5 l/s
Air Pressure	6.5 bar
Maximum Air Pressure	8 bar
File shank size	3,2 or 4 mm
Hose Coupling	1/4 inch
Size of Hose Recommended	1/4 inch
Vibration Level according to ISO 28927-8	3.2 m/s ² Uncertainty 0,8 m/s ²
Sound Pressure Level according to ISO 7574/2	81 dB (A)

Warning. Declared values obtained from lab testing according to standards can help compare tools. However, they are insufficient for accurate risk assessments. Actual exposure and risk of harm depend on additional factors.

Thank you for choosing a tool from IPT Technologies

The SRV-110 air saw is an advanced, actively vibration-dampened air saw, (System IPT). Following these simple instructions will ensure a long life of excellent operation.

Intended use

This product is intended for professional use only. Neither the product nor its accessories must be modified in any way. If the product or accessories have sustained damage, do not use them. Installation, operation, and servicing should be carried out exclusively by qualified personnel. Safety and adherence to these guidelines are paramount.

This product is designed for work with sheet metal (autobody panels, ductwork, etc.), aluminum and other non-ferrous metals, glass fiber, plastics, and wood. It will also serve as an excellent filing machine for many applications.











Important safety notes

All local safety rules regarding installation, operation, and maintenance shall always be followed. Always use adequate personal protective gear, such as safety goggles, noise protection, gloves, etc., as appropriate.

Always disconnect the tool from the air line before changing the file or making other adjustments.

Carefully blow the compressed air hose clean before connecting the tool to ensure there is no accumulation of water or dirt. The compressed air should be dry and clean. A filter unit should always be used.

Warnings

-  Do not exceed 8 bar pressure. Use a regulator set to 6 to 6,5 bars.
-  Power tools are not insulated for encountering electric power sources.
-  Power tools shall not be used in explosive atmospheres.
-  Do not use blades or files that are broken, cracked, or deformed.
-  Use only accessories designed for this tool.
-  Stored compressed air may cause a hazard.
-  Long hair or loose clothing may be drawn in or trapped by the power tool.
-  Make sure that any sparks emitted are directed so as not to cause a hazard.
-  Be aware of the risk of a whipping compressed air hose.
-  Use a facemask or respirator if the work creates dust.

Warranty

The SRV-110 air file is warranted for 12 months from the date of purchase against faulty workmanship or materials, provided the tool has not been opened by unauthorized persons and has constantly been lubricated and connected to a filtered air supply of the recommended pressure.

Please return any defective tool to your authorized supplier.

This warranty does not include repair or replacement required because of misuse, abuse, or normal wear and tear on wear parts.

Use only original IPT spare parts for any replacement. Other parts may result in hazardous conditions, decreased performance, and increased maintenance and wear.

Instructions for use

General Information

The air saw is designed to operate at an air pressure of 6 to 6.5 bar but will tolerate some variations without much change in performance. Do not exceed 8 bar pressure. Use a regulator set to 6.5 bar. Connect to ¼" hose connection.

Ensure there is no accumulation of water or dirt in the hose by carefully blowing the hose clean before connecting the tool. The compressed air should be dry and clean. A filter unit should always be used. In-line lubrication is recommended. Where this is unavailable, apply a generous amount of oil in the air supply hose 2 to 3 m upstream of the tool every 2 to 4 hours of operation. This is considerably more efficient than supplying oil directly to the tool inlet.

Operation

Use the recommendation of the saw blade manufacturer to select the appropriate TPI (Teeth Per Inch) for the application, or consult the suggestions below. Lubricants should be used when sawing high-alloy steel.

TPI	Recommended use
32	For very thin gauge metals, sheets, tubing trim, etc. (less than 1 mm).
24	For sheet metal with a 1 – 2 mm thickness, thin-wall tubing, formed sheet, trim, etc.
18	For heavy gauge sheet metal, conduit, pipe, tubing, thin fiberglass, etc.
14	For metal sheets around 3 mm thickness, bar stock, profiles, etc. Also for rubber, Masonite, fiberglass, etc.

NOTE: Make sure the blade is installed correctly with the teeth oriented as shown.

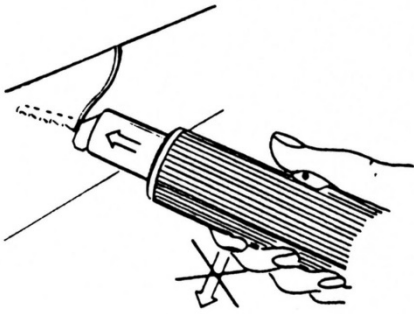

Push the front firmly against the sheet.

Don't press hard downwards. Teeth will strip.

NOTE: To ensure that saw blades last and to ensure optimal operation, it is important to let the saw do the work. Do not force the saw down; guide it only.

Sheets that are not supported often tend to vibrate. Push the front of the saw forward against the sheet to improve performance, but do not force the saw down.

If it is not activated, the throttle can be rotated to any position. Position it for the most comfort for the task at hand. As soon as it is depressed to start the saw, the throttle is automatically frozen in this position.

If the compressed air supply to the tool is interrupted, the throttle should be released. When the supply is reestablished, restart the tool.

The exhaust air cools the blade but can be further cooled by, e.g., water or lubricant.

Changing the blade

NOTE: Always disconnect the air file from the compressed air line when removing or attaching blades.

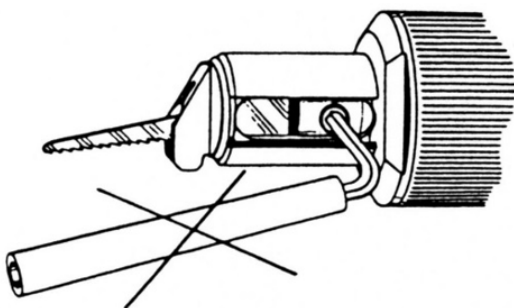

Use the Allen Key to loosen the Blade Lock Screw (4). Insert the blade until you can feel it at the bottom of the mounting slot. Tighten firmly by hand and ensure that the blade is properly clamped. **Use your fingers only.** Over-torquing will break the screw (M7 special)! Mount the blades shown in the figure. It will not work well if mounted upside down, even if you turn the saw around.

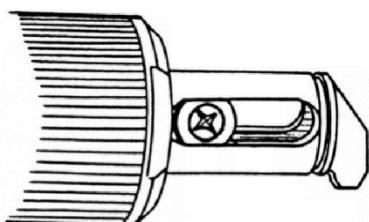

NOTE: DO NOT TOUCH THIS SCREW! IT KEEPS THE GUIDE IN PLACE. IF YOU LOOSEN IT, YOU WILL NEED TO APPLY STRONG LOCTITE TO AVOID IT FALLING OUT.

Troubleshooting

Saw Blade rotates when sawing

Guide (2) is missing. Replace. Note that Screw (3) has to be fastened with strong Loctite (No 270), or it will come loose during operation. Make sure the Guide does not bind in the Front. Use a thin sheet or blade (0.1 mm) between the Guide and the bottom of the groove in the Front when fixing the last turn of the Screw (3). See below.

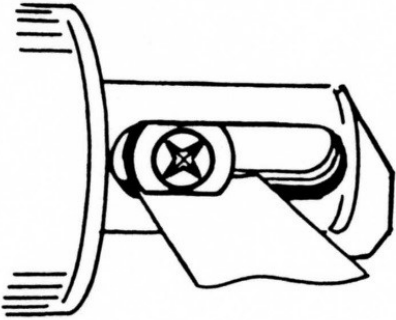
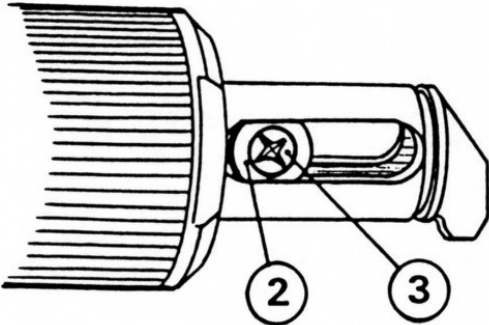

Maintenance



Lubricate regularly (apply a generous amount of oil in the air supply hose 2 to 3 m upstream of the tool). Use only quality air tool oil. If a continuous lubrication unit is used, it should be positioned 3 to 5 m upstream of the tool, or it will not be effective. The oil flow should be set to provide one drop of oil for every 150 liters of free air. If you tend to push the machine hard downwards during work, apply a couple of drops directly into the front part of the tool.

Lack of lubrication will result in excessive wear of critical parts inside the tool.

Note: Do not open the tool; it will void the warranty!

Disposal

This tool is designed and manufactured to last a long time if properly maintained, and all parts are available as spare parts. If you want to recycle it for any reason, please dismantle it completely, degrease it, and send the different materials separately for recycling according to local laws and regulations.

Accessories

SRV-110 is delivered with one of each saw blade: TPI 14, 24, and 32.



Spare Parts

Use only original IPT spare parts for any replacement! Other parts may result in hazardous conditions, decreased performance, increased wear, and damage to the tool.

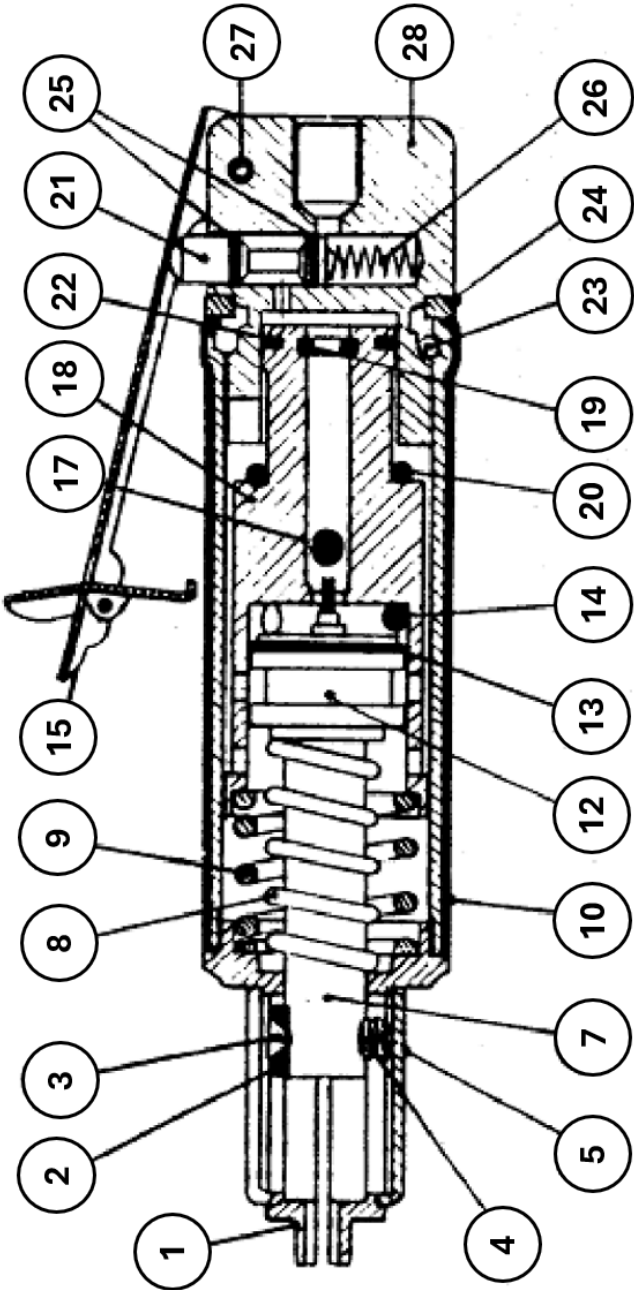

- | | | |
|------------------------------|----------------------------|------------------------------------|
| 1. S-100-01 Front | 12. S-100-12 Piston | 22. S-100-22 Piston Ring |
| 2. S-100-02 Guide | 13. S-100-13 Piston Ring | 23. S-100-23 Curved Cylinder |
| 3. S-100-03 Screw | 14. S-100-14 Limit Ring | 24. S-100-24 Lock Ring |
| 4. S-100-04 Blade Lock Screw | 15. S-110-15 Throttle | 25. S-100-25 O-ring (2 pcs needed) |
| 5. S-100-05 Front Cover | 17. S-100-17 Ball | 26. F-110-26 Valve Spring |
| 7. S-110-07 Piston Extension | 18. S-100-18 Cylinder | 27. S-100-27 Pin |
| 8. S-100-08 Spring | 19. S-100-19 Retainer | 28. S-110-28 Rear |
| 9. S-100-09 Spring | 20. S-110-20 O-ring | 29. S-100-29 Key (Not Shown) |
| 10. S-100-10 Housing | 21. F-110-21-ss Valve Stem | |