

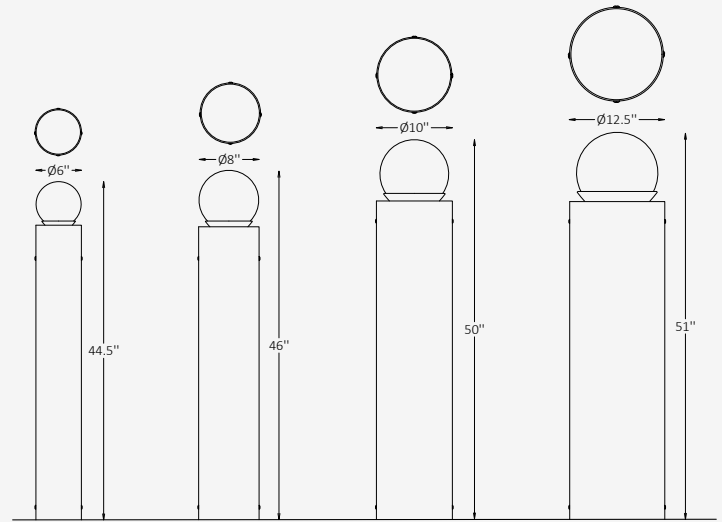

## GENERAL INFORMATION

The Ironroot SB is a security bollard that combines structural strength with architectural elegance. Designed to protect building perimeters, pedestrian areas, and vehicle-restricted zones, it features a refined cylindrical form topped with a frosted globe diffuser for 360° symmetrical illumination. This design provides both effective security and ambient lighting, enhancing safety without compromising aesthetics. Built from stainless steel with multiple finish options, the Ironroot SB delivers durability, impact resistance, and timeless visual appeal, making it suitable for modern urban environments and heritage settings alike.



## SPECIFICATIONS

Material	Stainless Steel + PMMA
Lens	Frosted, Acrylic
Length & Width	6" / 8" / 10" / 12.5"
Height	44.5" / 46" / 50" / 51"
Light Source Type	LED
Power	8W / 11W / 16W
Input Voltage	110-277V, 50-60 Hz
LED Output	80 lm/W
CCT	2200K / 3000K / 4000K
CRI	90
Dimming & Driver	Integral, 0-10V
Light Distribution	Type V — 360° Symmetrical
IP Rating	IP 65
Warranty	5 years
Finishes	19 standard finishes 8 wood-effect finishes 12 metallic finishes Custom on request*

## OTHER VERSIONS AVAILABLE



## CERTIFICATION



## Ordering Information

Select one item from each category below. If your desired option is unavailable, please contact our team for support or custom solutions.

Code	ASTM Rating / Diameter Ø / Height	Wattage / Lumens	Material
<input checked="" type="checkbox"/> <b>INR-SB</b> Security Bollard	<input type="checkbox"/> <b>S10</b> ASTM Rating S10 / 6" / 44.5" <input type="checkbox"/> <b>C40</b> ASTM Rating C40 / 8" / 46" <input type="checkbox"/> <b>M30</b> ASTM Rating M30 / 10" / 50" <input type="checkbox"/> <b>M50</b> ASTM Rating M50 / 12.5" / 51"	<input type="checkbox"/> <b>6</b> 8 W / 640 lm <input type="checkbox"/> <b>6</b> 11 W / 880 lm <input type="checkbox"/> <b>6</b> 16 W / 1280 lm <input type="checkbox"/> <b>Cus</b> Custom on request	<input checked="" type="checkbox"/> <b>SS</b> Stainless Steel
CCT	Light Distribution	Dimming	Accent Metal Finish Options
<input type="checkbox"/> <b>22</b> 2200K <input type="checkbox"/> <b>30</b> 3000K <input type="checkbox"/> <b>40</b> 4000K <input type="checkbox"/> <b>Cus</b> Custom on request	<input checked="" type="checkbox"/> <b>LD5</b> Type V — 360° / Symmetrical	<input type="checkbox"/> <b>NN</b> Non-Dimmable <input type="checkbox"/> <b>DM</b> 0-10V	<input type="checkbox"/> <b>ST</b> Standard <input type="checkbox"/> <b>WE</b> Wood effect <input type="checkbox"/> <b>MC</b> Metallic <input type="checkbox"/> <b>Cus</b> Custom on request
Bollard Body Finish Options			
<input type="checkbox"/> <b>ST</b> Standard <input type="checkbox"/> <b>WE</b> Wood effect <input type="checkbox"/> <b>MC</b> Metallic <input type="checkbox"/> <b>Cus</b> Custom on request			

## Finishes

### Standard finishes



### RAL K7 CLASSIC COLORS (80-95% GLOSS): RAL\_ \_ \_ \_

All RAL Classic colors are available with no setup fee.

On your specification submittal, choose your RAL color by entering the 4-digit RAL code (e.g., RAL 3003).



### Wood-effect finishes



### Metallic finishes

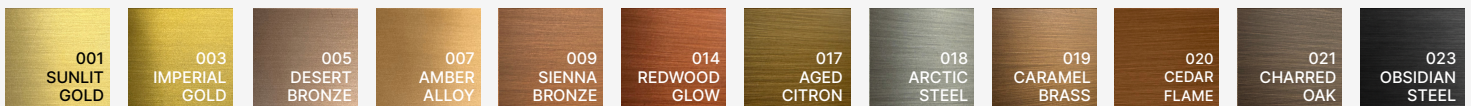

# Crash-Tested S10 Bollard Mounting Details

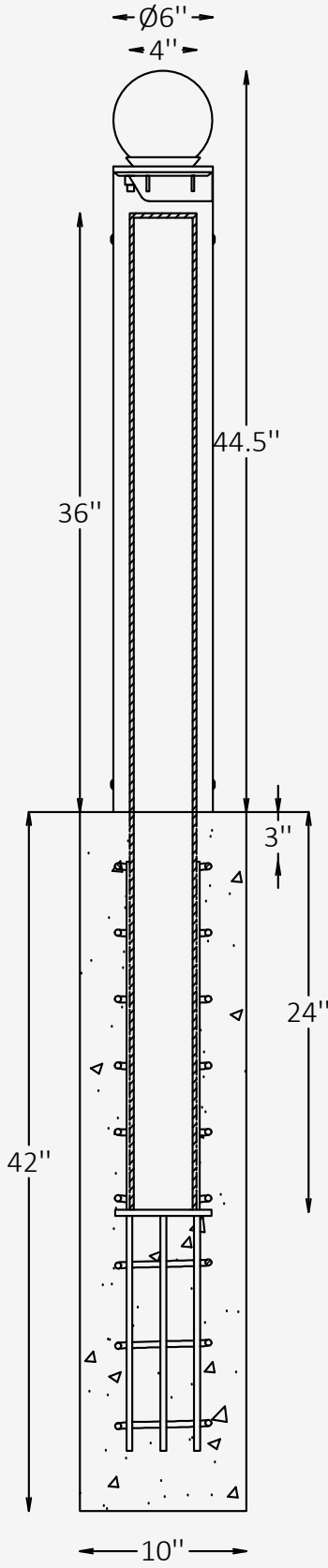

<b>Crash Rating</b>	ASTM F3016 S10 Crash Rated
<b>Rating Details</b>	Certified to meet ASTM F3016. Tested and proven to stop a 5,000 lb vehicle up to 10 mph.
<b>Minimum qty</b>	Bollards must be installed in a minimum array of three (3) units to achieve the specified crash rating. A single bollard alone does not meet the tested standard.

**MINIMUM GROUND CONDITIONS REQUIRED PER ASTM F3016**

- 1a: The concrete is 3000 psi minimum unconfined compressive strength, with one layer of #3 (Ø3/8") rebar spaced at 12" each way, with 1-1/4" cover at bottom. Rebar not shown here.
- 1b: The base is Type A Grade 1 crushed limestone road base, compacted to 90% of standard proctor density.
- 1c: The washed sand shall be classified as SP - poorly graded sand & be compacted to a density of not less than 90% maximum dry density

**KITTED SYSTEM**

We provide everything but the concrete – core, cover, rebar cage and hardware are all included.

**EASY TO INSTALL**

CrashCore Bollards have a simple core drilled installation — so simple you can install one in less than an hour.

# Crash-Tested C40 Bollard Mounting Details

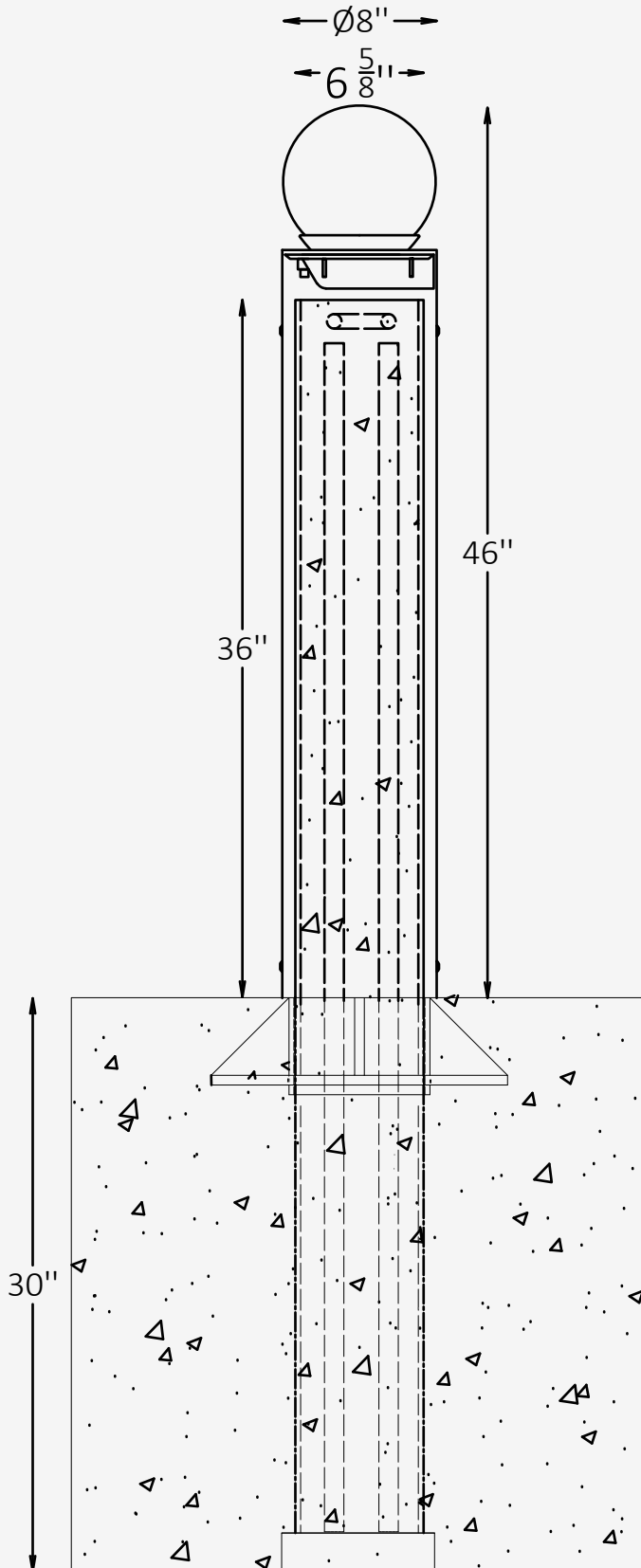

<b>Crash Rating</b>	ASTM F2656 C40, P1 Crash Rated
<b>Rating Details</b>	Certified to meet F2656-07 standards. Capable of halting a 2,342 lb. vehicle traveling at 40 mph.
<b>Minimum qty</b>	Bollards must be installed in a minimum array of three (3) units to achieve the specified crash rating. A single bollard alone does not meet the tested standard.

### MINIMUM GROUND CONDITIONS REQUIRED PER ASTM F2656-07

1a: The concrete shall be 4000 psi minimum unconfined compressive strength, poured to a 30" depth. Each bollard is factory-filled with concrete and includes two pre-cut vertical rebars (installer-supplied) placed inside the bollard tube

1b: Masonry blocks or rebar chairs shall be used to elevate the bollard steel off of the subgrade, ensuring proper concrete coverage below the tube. The base is prefabricated and delivered as a single unit, requiring no field welding, bolting, or assembly.

1c: The system supports unrestricted spacing between bollards and is suitable for sloped or curved installations without modification. Symmetrical bollard design ensures uniform impact resistance from any direction

### BOLLARD SPACING

We provide everything but the concrete – core, cover, rebar cage and hardware are all included.

### EASY TO INSTALL

Easy and quick installation; excavate set bollard and pour concrete

# Crash-Tested M30 Bollard Mounting Details

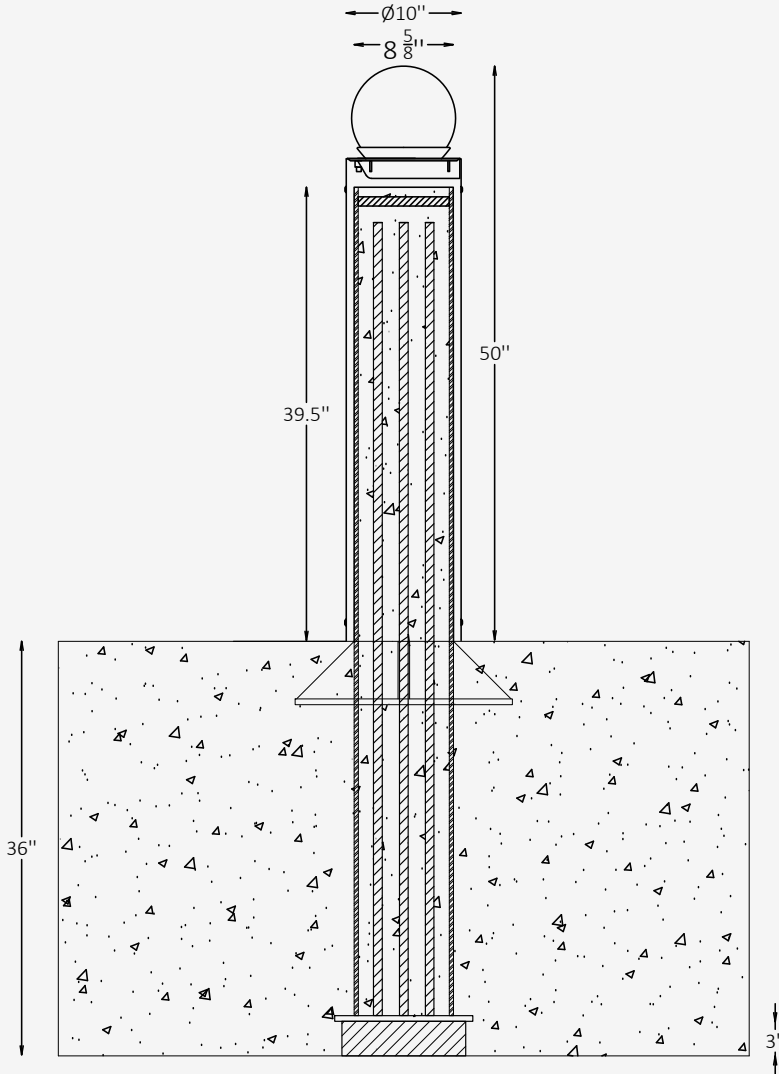

**Crash Rating** ASTM F2656-07 - M30/P1 Crash Rated  
**Rating Details** Certified to meet F2656-07 standards. Stops 15,000 lb. vehicle traveling at 30 mph  
**Minimum qty** Bollards must be installed in a minimum array of three (3) units to achieve the specified crash rating. A single bollard alone does not meet the tested standard.

### MINIMUM GROUND CONDITIONS REQUIRED PER ASTM F2656-07

1a: 1a: The concrete shall be 4000 psi minimum unconfined compressive strength, poured to a depth of 36". Each bollard tube is filled to the top with concrete and contains six (6) vertical #6 rebars (68" long), inserted inside the steel pipe .

1b: A 12" x 12" x 1/2" steel base plate is welded to the bottom of the bollard tube. The bollard must be elevated 3" off subgrade using masonry blocks or rebar chairs, ensuring proper embedment of the foundation and alignment with the concrete surface.

1c: The system is prefabricated and designed for "set and pour" installation with no rebar required in the foundation itself. Standard spacing between bollards is 60" on center, with a 51-3/8" clear span, although modifications are allowed for site-specific conditions

### BOLLARD SPACING

Recommended 60 inches (1524 mm) maximum on-center (o/c) spacing.

### EASY TO INSTALL

The set & pour method simplifies the entire installation process. With no rebar being required, install time and cost is reduced by nearly 50%.

# Crash-Tested M30 Shallow Mount Bollard Mounting Details

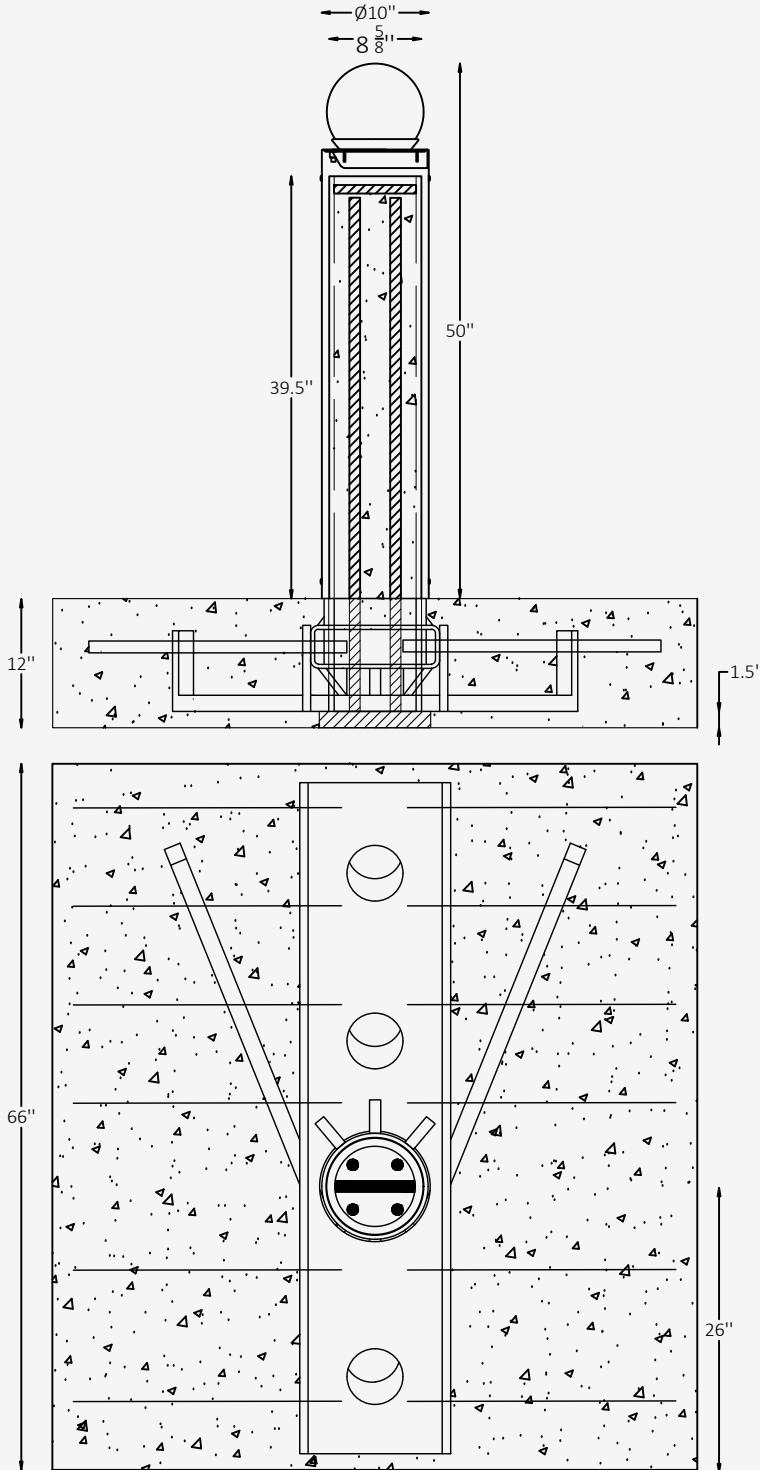

<b>Crash Rating</b>	ASTM F2656-07 - M30/P1 Crash Rated
<b>Rating Details</b>	Certified to meet F2656-07 standards. Capable of halting a 2,342 lb. vehicle traveling at 40 mph.
<b>Minimum qty</b>	Bollards must be installed in a minimum array of three (3) units to achieve the specified crash rating. A single bollard alone does not meet the tested standard.

## MINIMUM GROUND CONDITIONS REQUIRED PER ASTM F2656-07

1a: The foundation shall consist of 3000 psi concrete, poured to a depth of 12", compacted over a properly tamped subgrade. The bollard tube is filled to the top with concrete and reinforced with four (4) vertical #8 rebar, each 48" long (provided by manufacturer)

1b: A 9-5/8" Schedule 40 steel collar surrounds an 8-5/8" Schedule 120 steel bollard pipe. The bollard is supported on 1-1/2" masonry blocks or chairs to elevate it above the subgrade, ensuring the top of the collar aligns with the finished concrete grade.

1c: The shallow mount system includes six (6) #5 horizontal rebar per bollard, each inserted 3" into pre-drilled holes in the adjacent bollard pipes for lateral reinforcement. Standard spacing is 54" on center, with a clear span of 45-3/8", although modified layouts are available for site-specific conditions

## BOLLARD SPACING

Recommended 60 inches (1524 mm) maximum on-center (o/c) spacing.

## SHALLOW FOUNDATION

With a shallow foundation of only 12" deep, our system avoids potential conflicts with underground utilities.

## Crash-Tested M50 Bollard Mounting Details

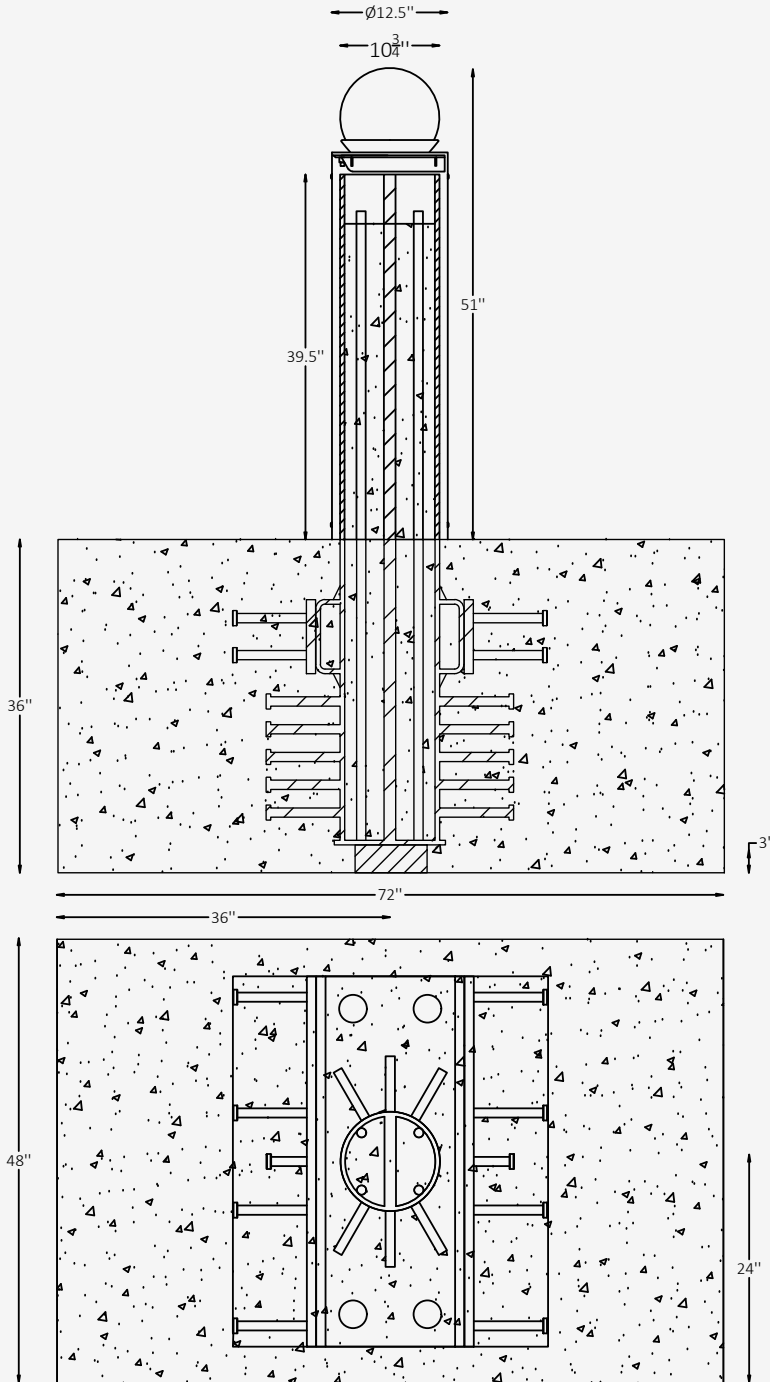

<b>Crash Rating</b>	ASTM F2656 M50-P2 Crash Rated
<b>Rating Details</b>	Certified to meet F2656 standards. Stops 15,000 lb. vehicle traveling at 50 mph
<b>Minimum qty</b>	Bollards must be installed in a minimum array of three (3) units to achieve the specified crash rating. A single bollard alone does not meet the tested standard.

### MINIMUM GROUND CONDITIONS REQUIRED PER ASTM F2656

1a: The foundation shall be poured using 4000 psi minimum compressive strength concrete, to a depth of 36" (914 mm). Each bollard is filled to the top with concrete and reinforced with four (4) #8 rebars (60 ksi), each 68" long, pre-inserted into the steel

1b: A 10-3/4" diameter Schedule 40 steel pipe is welded to a base and includes no field-assembly components. The bollard is factory-preassembled, requiring no bolting, tying, or installation beyond placement and concrete pour. It is supported on 3" masonry blocks or chairs to elevate it above subgrade for full encapsulation .

1c: Standard embedment depth is 33" (838 mm) below grade, with 39-1/2" (1003 mm) above grade. Typical center-to-center spacing is 60", with the system capable of achieving M50-P1 rating in a three-bollard array. A single bollard provides M50-P2 rating, stopping a 15,000 lb vehicle at 50 mph

### BOLLARD SPACING

Recommended 60 inches (1524 mm) maximum on-center (o/c) spacing.

### EASY TO INSTALL

No bolting, tying, or assembly is required for the bases - prefabricated units drop into standard excavations without specialty subgrade.