

# KS2 1

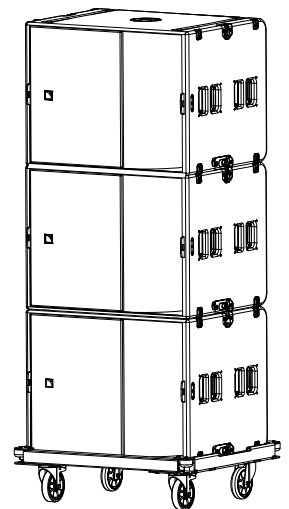

owner's manual (EN)

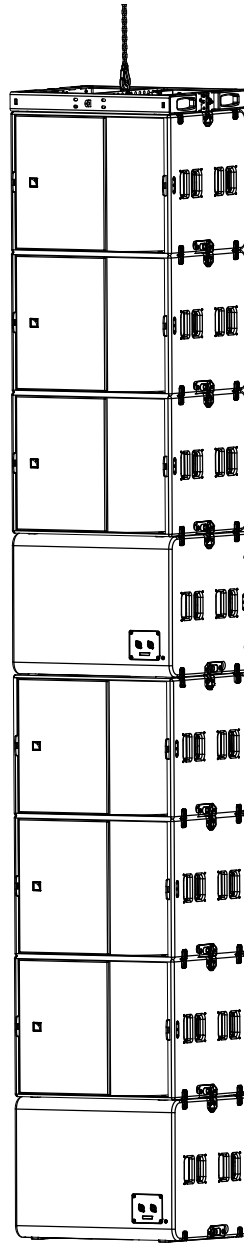
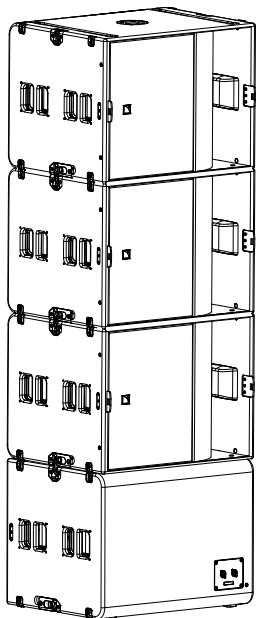

Document reference: KS21 owner's manual (EN) version 2.1

Distribution date: September 30, 2019

© 2019 L-Acoustics. All rights reserved.

No part of this publication may be reproduced or transmitted in any form or by any means without the express written consent of the publisher.

## Contents







Safety.....	5
Instructions.....	5
Introduction.....	7
KS21 compact reference subwoofer.....	7
How to use this manual.....	7
System components.....	8
Loudspeaker cables.....	9
Rigging elements.....	10
Electro-acoustical description.....	11
Preset description.....	11
Connectors.....	11
Rigging system description.....	12
KS21.....	12
Rigging elements for flown arrays.....	14
A15-BUMP.....	14
A15-RIGBAR.....	16
Rigging elements for stacked arrays.....	18
KS21-OUTRIG.....	18
K2-JACK.....	19
Storage and handling elements.....	21
KS21-CHARIOT.....	21
KS21-PLA.....	22
KS21-COV and KS21-CHARIOTCOV.....	23
Mechanical safety.....	24
Loudspeaker configurations.....	26
KS21 in standard configuration.....	26
KS21 in cardioid configuration.....	27
Inspection and preventive maintenance.....	28
How to do preventive maintenance.....	28
Rigging part inspection.....	29
Mechanical system overview.....	29
Inspection references.....	35
Rigging check.....	42
Acoustical check.....	44

Rigging procedures.....	47
Flying.....	47
Flying a vertical array with A15-BUMP/A15-RIGBAR.....	47
Stacking.....	52
Stacking KS21 on KS21-CHARIOT.....	52
Attaching K2-JACK stabilizers to KS21-CHARIOT.....	54
Connection to LA amplified controllers.....	57
Corrective maintenance.....	58
Specifications.....	63
APPENDIX A: Recommendation for speaker cables.....	71

# Safety

## Instructions

---

-  **Inspect the system before any deployment.**  
Perform safety related checks and inspections before any deployment.
- Perform preventive maintenance at least once a year.**  
Refer to the preventive maintenance section for a list of actions and their periodicity.  
Insufficient upkeep of the product can void the warranty.
- If any safety issue is detected during inspection, do not use the product before performing corrective maintenance.**  
Check for issues. A rigging system part or fastener is missing or loose. A rigging system part exhibits: bends, breaks, broken parts, corrosion, cracks, cracks in welded joints, deformation, denting, wear, holes. A safety cue or label is missing. A loose part is not adequately secured.
-  **Never incorporate equipment or accessories not approved by L-Acoustics.**
-  **Read all the related PRODUCT INFORMATION documents shipped with the products before exploiting the system.**
-  **Do not store the product on an unstable cart, stand, tripod, bracket, or table.**
-  **Beware of sound levels.**  
Do not stay within close proximity of loudspeakers in operation.  
Loudspeaker systems are capable of producing very high sound pressure levels (SPL) which can instantaneously lead to permanent hearing damage to performers, production crew and audience members. Hearing damage can also occur at moderate level with prolonged exposure to sound.  
Check the applicable laws and regulations relating to maximum sound levels and exposure times.
-  **Work with qualified personnel for rigging the system**  
Installation should only be carried out by qualified personnel that are familiar with the rigging techniques and safety recommendations outlined in this manual.
- Ensure personnel health and safety**  
During installation and set-up personnel must wear protective headgear and footwear at all times. Under no circumstances is personnel allowed to climb on a loudspeaker assembly.
- Respect the Working Load Limit (WLL) of third party equipment.**  
L-Acoustics is not responsible for any rigging equipment and accessories provided by third party manufacturers. Verify that the Working Load Limit (WLL) of the suspension points, chain hoists and all additional hardware rigging accessories is respected.
- Respect the maximum configurations and the recommended safety precautions.**  
For safety issue, respect the maximum configurations outlined in this manual. To check the conformity of any configuration in regards with the safety precautions recommended by L-Acoustics, model the system in Soundvision and refer to the warnings in Mechanical Data section.
- Be cautious when flying a loudspeaker configuration.**  
Before installing/raising the product, check each individual element to make sure that it is securely fastened to the adjacent element. Always verify that no one is standing underneath the product when it is being installed/raised. Never leave the product unattended during the installation process.  
As a general rule, L-Acoustics recommends the use of secondary safety at all times.
- Be cautious when ground-stacking a loudspeaker array.**  
Do not stack the loudspeaker array on unstable ground or surface. If the array is stacked on a structure, platform, or stage, always check that the latter can support the total weight of the array.  
As a general rule, L-Acoustics recommends the use of safety straps at all times.

### **Risk of falling objects**

Verify that no unattached items remain on the product or assembly.

### **Risk of tipping**

Remove all rigging accessories before transporting a product or an assembly.

### **Take into account the wind effects on dynamic load.**

When a loudspeaker assembly is deployed in an open air environment, wind can produce dynamic stress to the rigging components and suspension points.

If the wind force exceeds 6 bft (Beaufort scale), lower down and/or secure the product or the assembly.



### **Intended use**

This system is intended for use by trained personnel for professional applications.



**As part of a continuous evolution of techniques and standards, L-Acoustics reserves the right to change the specifications of its products and the content of its documents without prior notice.**

Check [www.l-acoustics.com](http://www.l-acoustics.com) on a regular basis to download the latest document and software updates.

### **Read the maintenance section of this document before servicing the product.**



### **Do not expose the product to extreme conditions.**

Do not expose the product to moisture (rain, mist, sea spray, steam, humidity, condensation...) or excessive heat (direct sun, radiator...) for a long period of time.

For more information, refer to the **Product protection ratings** document, available on the website.



### **Contact L-Acoustics for advanced maintenance.**

Any unauthorized maintenance operation will void the product warranty.

# Introduction

## KS21 compact reference subwoofer

---

KS21 is a compact reference subwoofer designed to extend the bandwidth of A15 and A10 systems. KS21 features one high excursion, direct radiating 21" transducer mounted in a bass-reflex tuned enclosure.

KS21 operates from 29 Hz to 60 Hz when associated with A15, or 30 Hz to 100 Hz when associated with A10. KS21 features L-Vents that substantially reduce turbulence and port noise at high levels while also increasing LF efficiency.

The KS21 frequency response is optimized to couple perfectly with both systems. KS21 features a two-point, integrated rigging system that is compatible with A15. Combinations of KS21 and A15 can be flown or stacked to form a full range line source. KS21 also integrates a threaded insert to enable pole-mount configurations of A15 or A10.

KS21 can be deployed in standard or cardioid configurations with dedicated presets, for flown and stacked deployment.

## How to use this manual

---

The KS21 owner's manual is intended for all actors involved in the system design, implementation, preventive and corrective maintenance of the KS21 system. It must be used as follows:

1. Read the technical description for an overview of all system elements, their features, and their compatibilities.
  - [Electro-acoustical description](#) (p.11)
  - [Rigging system description](#) (p.12)
2. Prepare the system configuration. Consider the mechanical limits and the available acoustical configurations.
  - [Mechanical safety](#) (p.24)
  - [Loudspeaker configurations](#) (p.26)
3. Before rigging the system, perform mandatory inspections and functional checks.
  - [Inspection and preventive maintenance](#) (p.28)
4. To deploy the system, follow the step-by-step rigging instructions and refer to the cabling schemes.
  - [Rigging procedures](#) (p.47)
  - [Connection to LA amplified controllers](#) (p.57)



The [Corrective maintenance](#) (p.58) section contains the operations authorized for the end user.

Performing another operation exposes to hazardous situations.

For advanced maintenance, contact your L-Acoustics representative.

**As part of a continuous evolution of techniques and standards, L-Acoustics reserves the right to change the specifications of its products and the content of its document without prior notice.** Please check [www.l-acoustics.com](http://www.l-acoustics.com) on a regular basis to download the latest document and software updates.

## Contact information

For information on advanced corrective maintenance:

- contact your Certified Provider or your L-Acoustics representative
- for Certified Providers, contact the L-Acoustics customer service: [customer.service@l-acoustics.com](mailto:customer.service@l-acoustics.com)

## Symbols

The following symbols are used in this document:



This symbol indicates a potential risk of harm to an individual or damage to the product.

It can also notify the user about instructions that must be strictly followed to ensure safe installation or operation of the product.



This symbol notifies the user about instructions that must be strictly followed to ensure proper installation or operation of the product.



This symbol notifies the user about complementary information or optional instructions.

## System components

### Loudspeaker enclosures

KS21 High power compact subwoofer: 1x21"

### Powering and driving system

LA4X / LA8 / LA12X Amplified controller with DSP, preset library and networking capabilities



Refer to the LA4X / LA8 / LA12X user manual for operating instructions.

### Loudspeaker cables

SP cables	4-point speakON loudspeaker cables (4 mm <sup>2</sup> gauge) SP cables come in four sizes: SP.7 (0.7 m/2.3 ft), SP5 (5 m/16.4 ft), SP10 (10 m/32.8 ft) and SP25 (25 m/82 ft)
SP-Y1	breakout cable for two passive enclosures (2.5 mm <sup>2</sup> gauge) provided with a CC4FP adapter 4-point speakON to 2 × 2-point speakON
DO	8-point PA-COM loudspeaker cables (4 mm <sup>2</sup> gauge) DO cables come in three sizes: DO.7 (0.7 m/2.3 ft), DO10 (10 m/32.8 ft) and DO25 (25 m/82 ft)
DOSUB-LA8	breakout cable for four passive enclosures (4 mm <sup>2</sup> gauge) 8-point PA-COM to 4 × 2-point speakON



**Information about the connection of the enclosures to the LA amplified controllers is given in this document.**

Refer to the LA4X / LA8 / LA12X user manual for detailed instructions about the whole cabling scheme, including modulation cables and network.

### Rigging elements

A15-BUMP	Flying frame for vertical deployment of A15 and KS21
A15-RIGBAR	Rigging bar and pullback for A15 and KS21
KS21-OUTRIG	Stability bars for KS21
K2-JACK	4 tilt adjustment screw jacks + bar for K2-CHARIOT
CLAMP250	Clamp certified for 250 kg

### Transportation accessories

KS21-CHARIOT	Chariot for up to 3 KS21
KS21-COV	Protective cover for 1 KS21
KS21-PLA	Removable front dolly for 1 KS21
KS21-CHARIOTCOV	Protective cover for 2 or 3 KS21 on KS21-CHARIOT

### Software applications

Soundvision	3D acoustical and mechanical modeling software
LA Network Manager	Software for remote control and monitoring of amplified controllers



Refer to the **Soundvision** help.

Refer to the **LA Network Manager** help.

## Loudspeaker cables

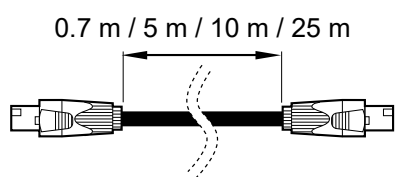

**SP.7 / SP5 / SP10 / SP25**

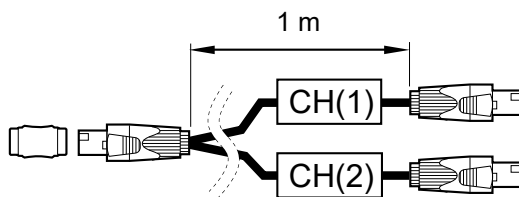

**SP-Y1**

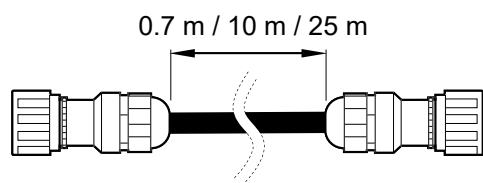

**DO.7 / DO10 / DO25**

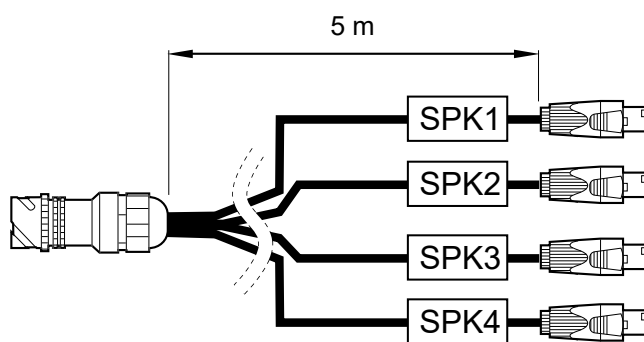

**DOSUB-LA8**

## Rigging elements

---

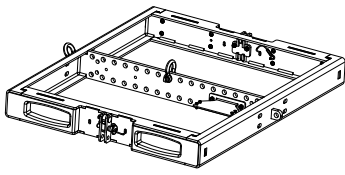

A15-BUMP

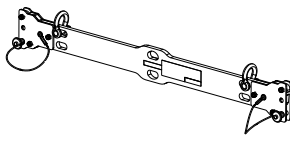

A15-RIGBAR

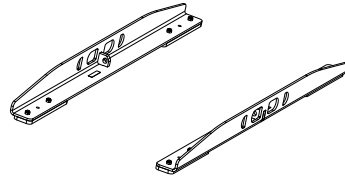

KS21-OUTRIG

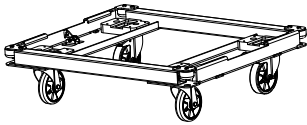

KS21-CHARIOT

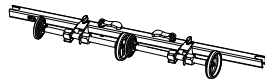

K2-JACK

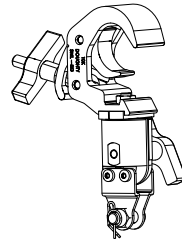

CLAMP250

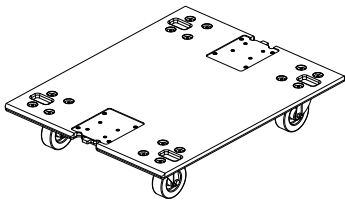

KS21-PLA

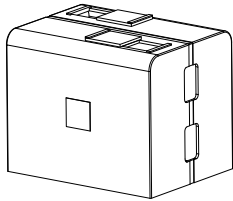

KS21-COV

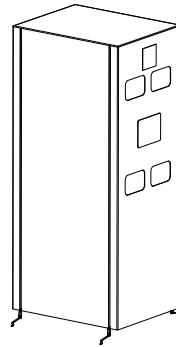

KS21-CHARIOTCOV

## Electro-acoustical description

### Preset description

[KS21\_60] [KS21\_100]

outputs	channels	routing	gain	delay	polarity	mute
OUT 1	SB	IN A	0 dB	0 ms	+	ON
OUT 2	SB	IN A	0 dB	0 ms	+	ON
OUT 3	SB	IN A	0 dB	0 ms	+	ON
OUT 4	SB	IN A	0 dB	0 ms	+	ON

[KS21\_60\_C] [KS21\_100\_C] [KS21\_60\_Cx] [KS21\_100\_Cx]

loudspeaker elements	outputs	channels	routing	gain	delay	polarity	mute
SR	OUT 1	SR	IN A	0 dB	0 ms	+	ON
SB	OUT 2	SB					ON
SB	OUT 3	SB					ON
SB	OUT 4	SB					ON

### Connectors

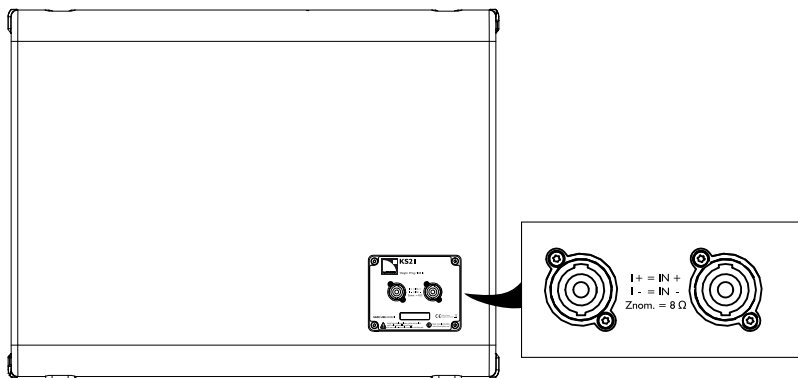

KS21

2 x 4-point speakON

### Internal pinout for L-Acoustics subwoofers

speakON points	1 +	1 -	2 +	2 -
Transducer connectors	LF +	LF -	Not linked	Not linked

## Rigging system description

### KS21

The rigging system of KS21 consists of two elements:

- A rotating rigging arm.
- A spring-loaded pin.

**i** Push and slide to unlock the spring-loaded pin.

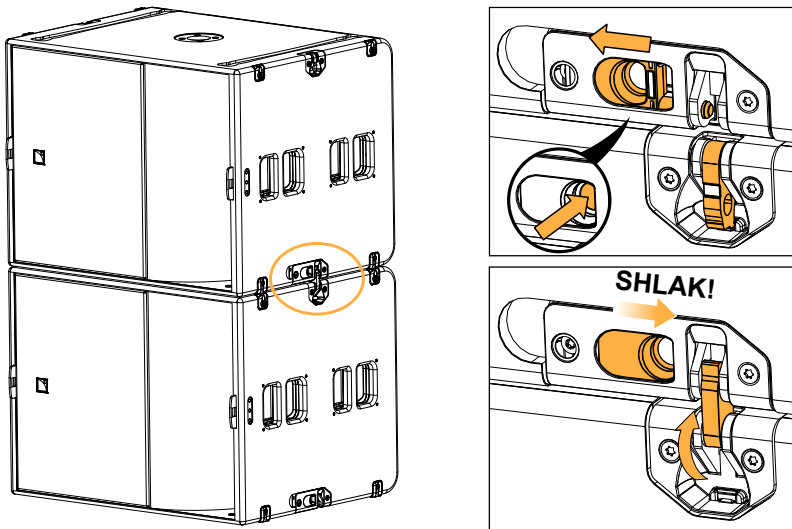

The rigging elements are fitted with yellow safety labels that are visible when they are not safely locked.

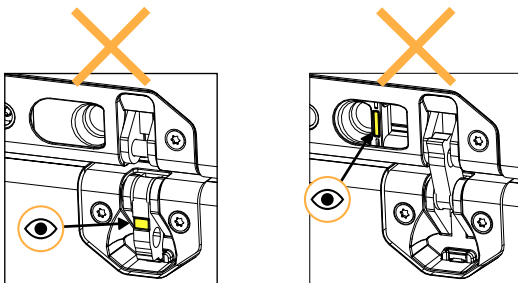

KS21 displays two ground runners on the bottom and two matching tracks on the top.

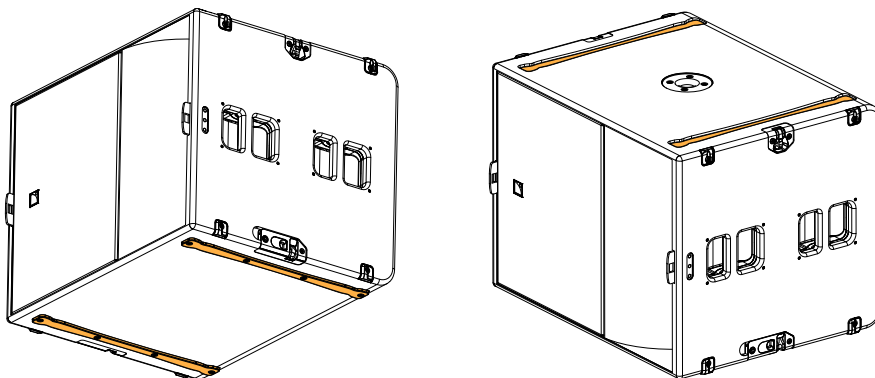

Eight corner stops protect the side panels during handling.

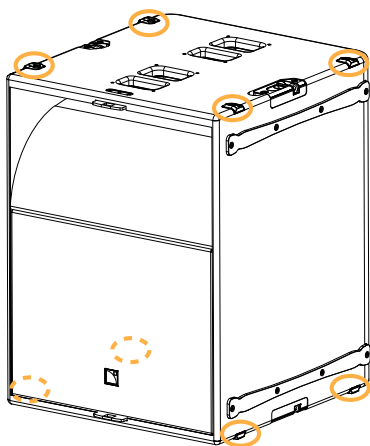

The logo on the enclosure front can be rotated to adapt to every configuration.

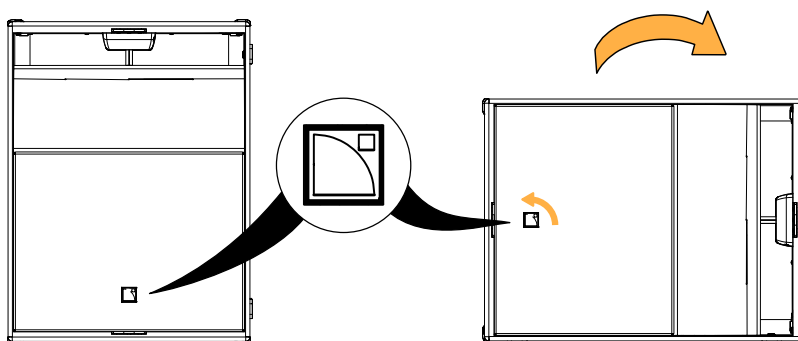

KS21 features a 35 mm pole-socket which contains an M20x150 insert.

**! Use a 35 mm diameter pole**

The pole can be non-threaded or with M20 thread.

Use an adapter for poles with other dimensions, for example the 21329 adapter by K&M, available on [www.k-m.de/en](http://www.k-m.de/en).

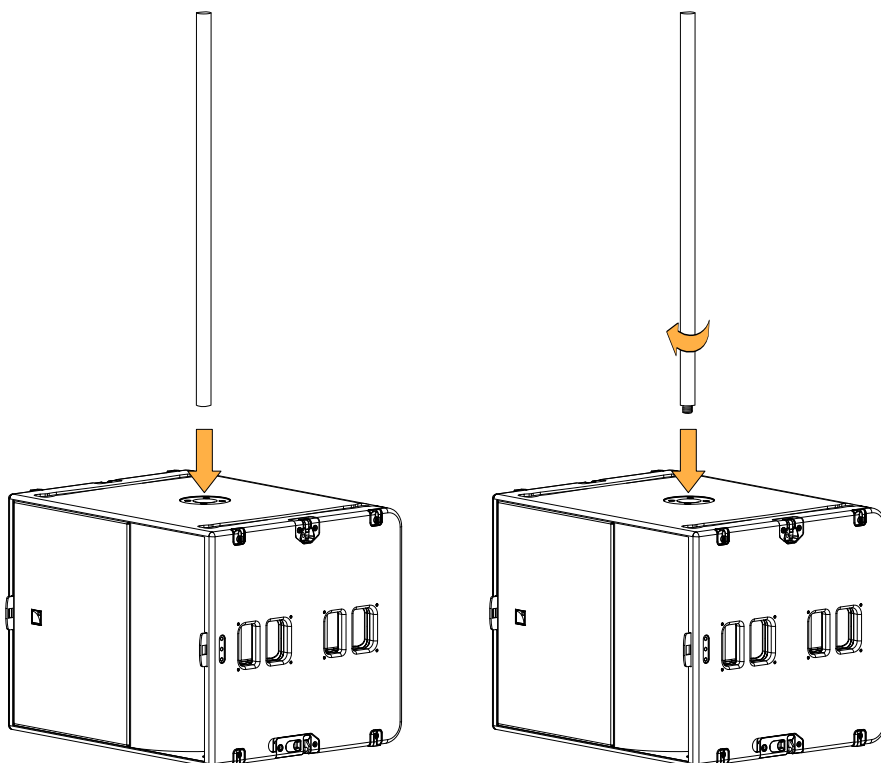

Four handles are available for transportation.

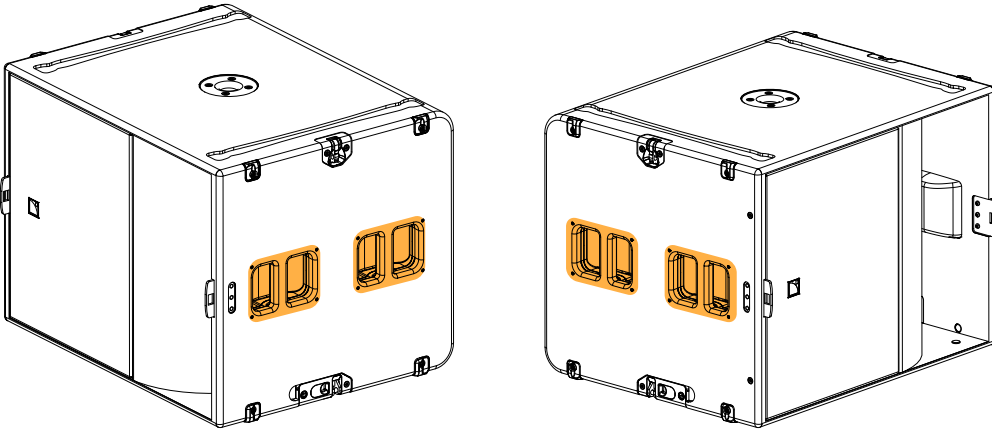

**! Dedicated chariot and dolly board for KS21**

KS21 is intended for use only with L-Acoustics KS21-CHARIOT and KS21-PLA.  
Use with other equipment may result in instability causing injury.

**Rigging elements for flown arrays**

---

**A15-BUMP**

A15-BUMP is a reversible rigging frame for flying vertical arrays of KS21.

A15-BUMP is equipped with rotating rigging arms and ball-locking pins, to match the rigging systems of KS21 on either side.

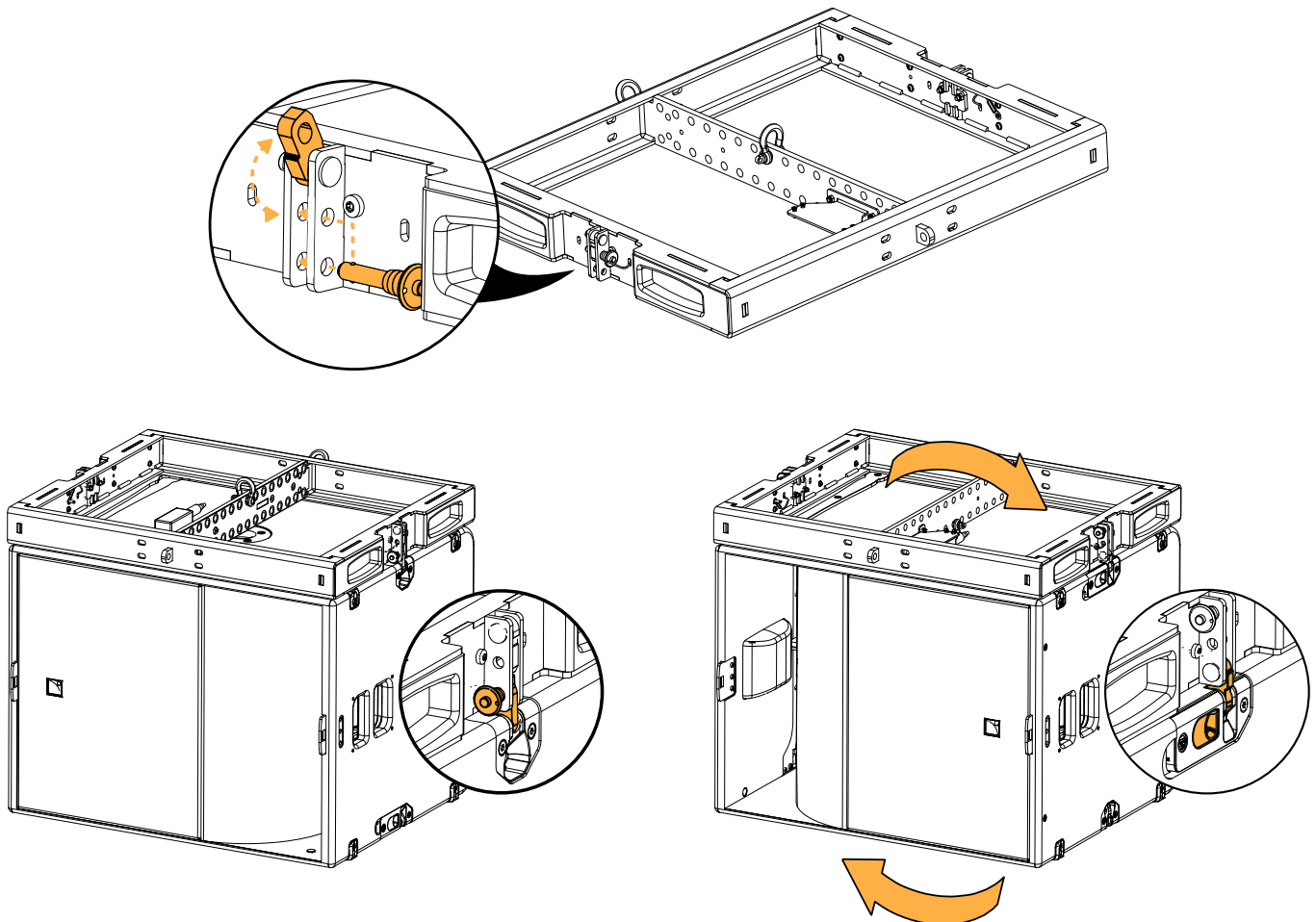

The rigging arms are fitted with yellow safety labels, that are visible when the rigging arm is not in use.

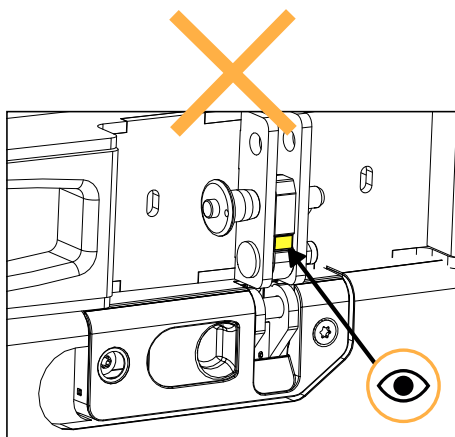

16 pickup points on each side, one front pickup point (F), and one rear pickup point (R), are available for site angle adjustments. They are compatible with Ø12 mm shackles WLL 1 t (two provided) and CLAMP250.

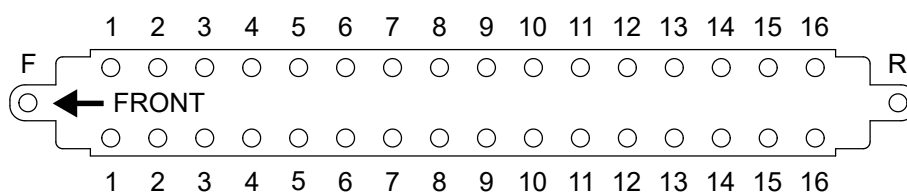

A15-BUMP can be used as the main lifting accessory for flying vertical arrays of KS21 with one or two lifting points.

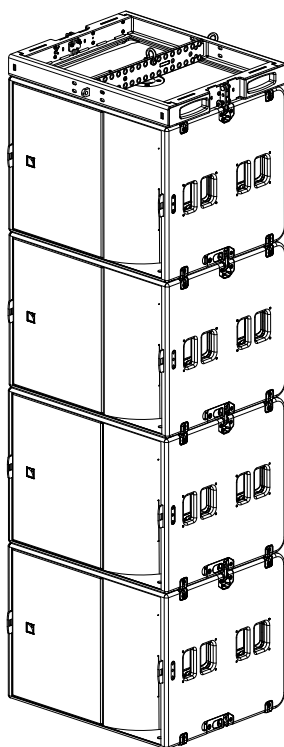

## A15-RIGBAR

A15-RIGBAR is a reversible rigging bar. It can be used as a pullback or for flying vertical arrays of up to four KS21.

A15-RIGBAR is equipped with rotating rigging arms and ball-locking pins, to match the rigging systems of KS21 on either side.

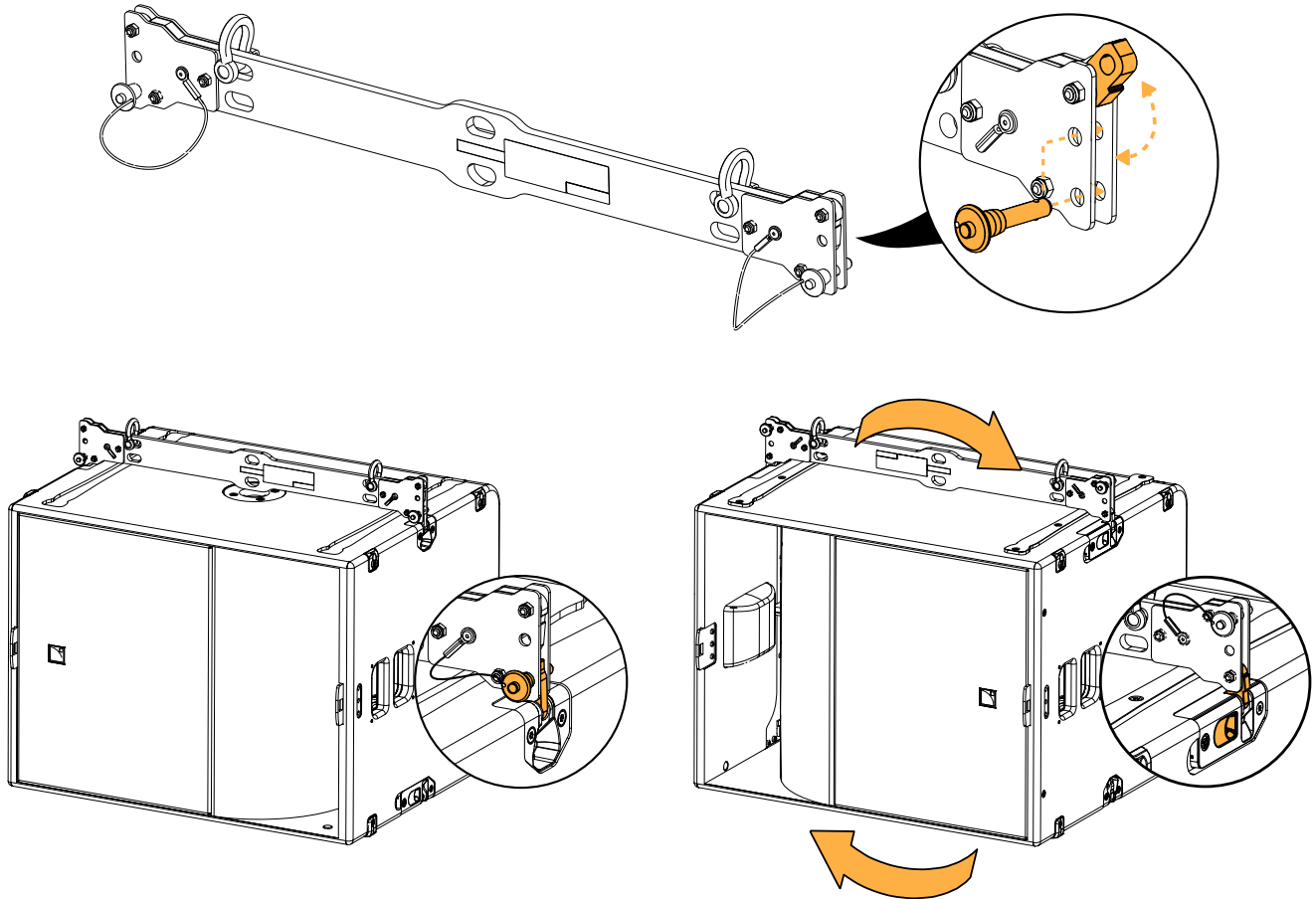

The rigging arms are fitted with yellow safety labels, that are visible when the rigging arm is not in use.

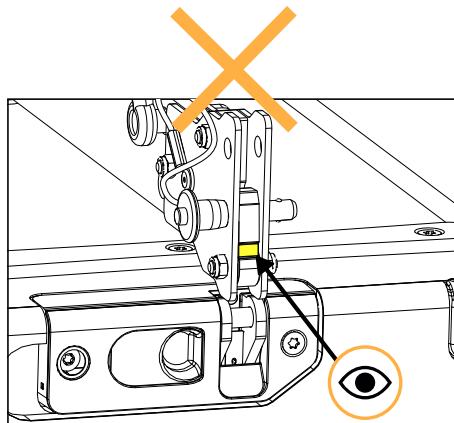

A15-RIGBAR can be used as the main lifting accessory, to provide a lightweight solution for flying four KS21 with one or two lifting points.

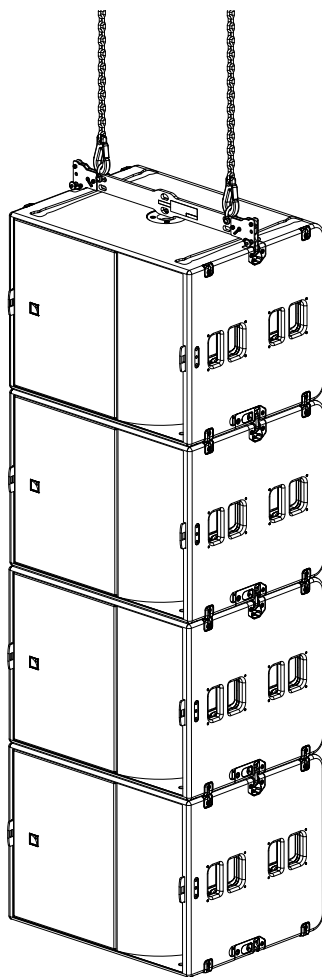

The pickup points are compatible with Ø12 mm shackles WLL 1 t (two provided) and CLAMP250.

**!** When using A15-RIGBAR as the main lifting accessory, always implement a secondary safety using available holes.

**One pickup point**

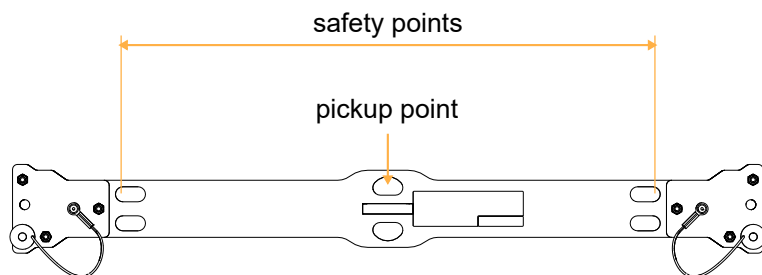

**Two pickup points**

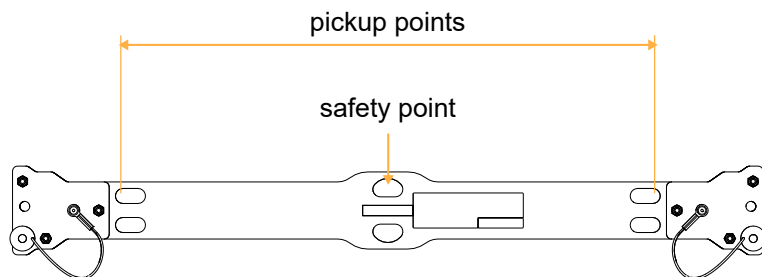

## Rigging elements for stacked arrays

### KS21-OUTRIG

KS21-OUTRIG is a set of two stability bars for KS21. Secure KS21-OUTRIG at the bottom of a KS21 array to improve the stability of the array. The use of KS21-OUTRIG is mandatory when A15 Wide/Focus or A10 Wide/Focus are stacked on top of KS21.

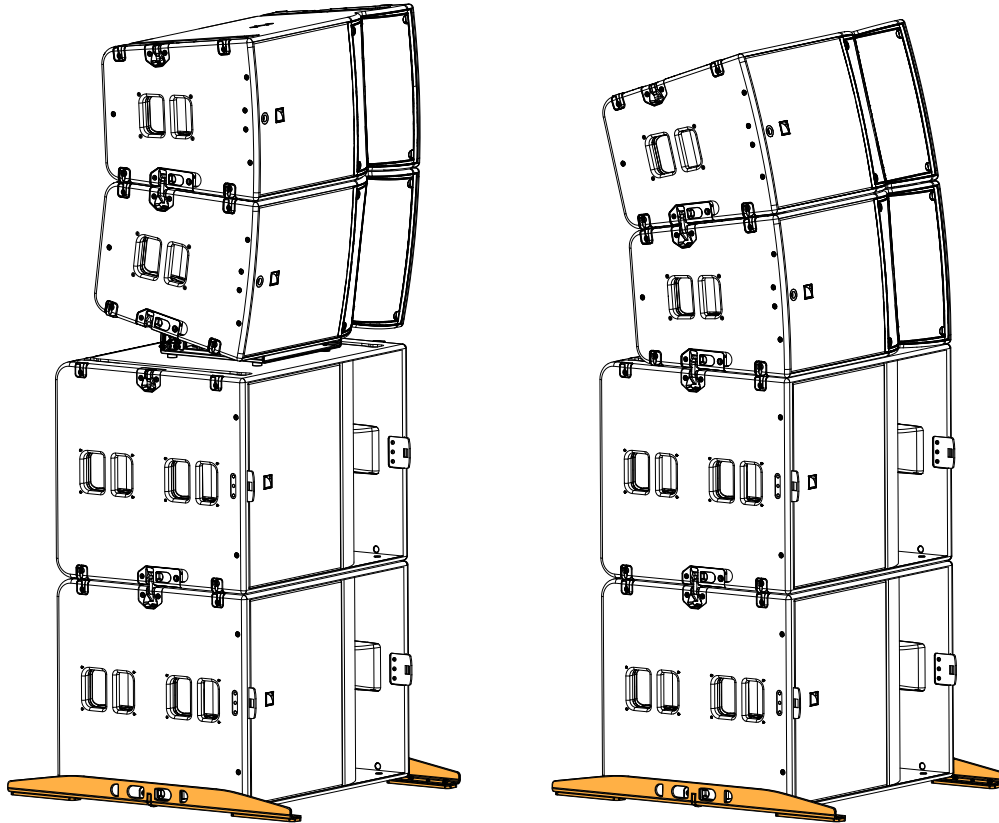

KS21-OUTRIG matches the rigging system of KS21.

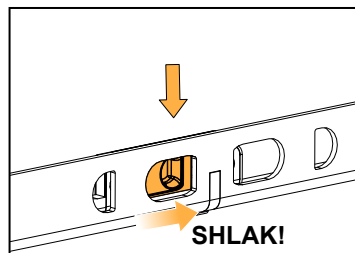
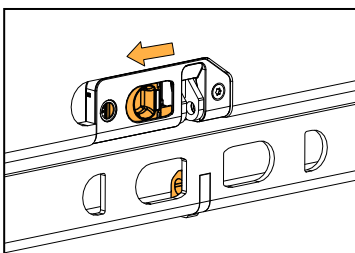

Two runners on each KS21-OUTRIG bar ensure stability. Four  $\varnothing$  6.5 mm holes are available to secure the assembly to the floor.

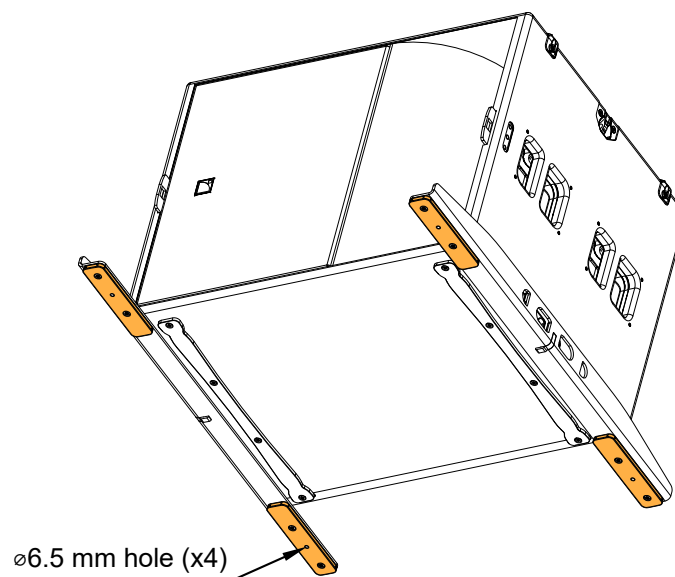

## K2-JACK

K2-JACK is a set of two bars and four feet with screw jacks and hand wheels. K2-JACK can be fitted onto [KS21-CHARIOT](#) (p.21) to improve stability or correct floor discrepancies.

**i** During transportation, make sure the bolts are tightened.

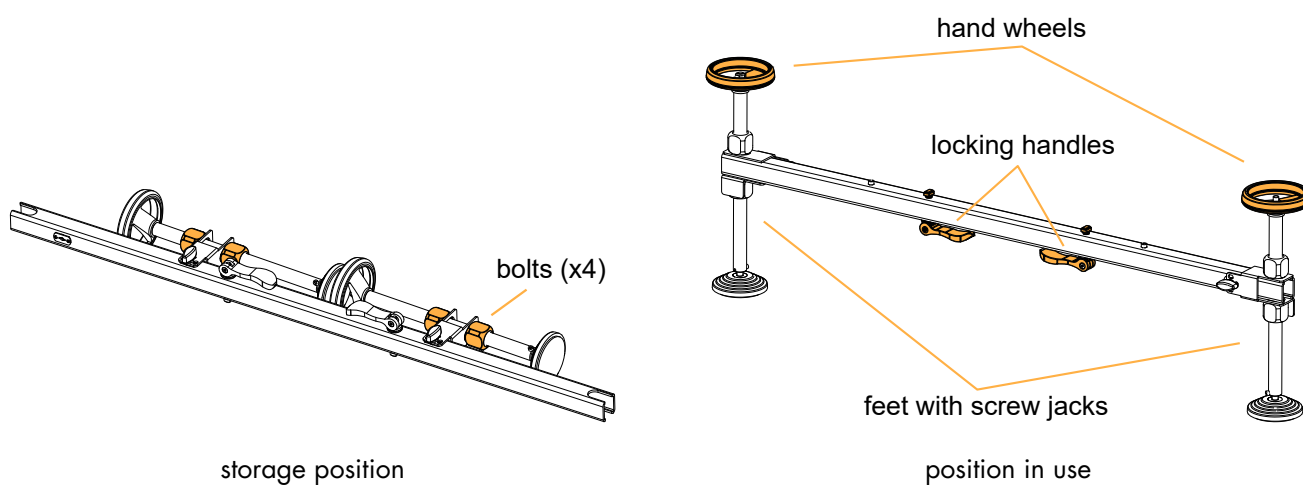

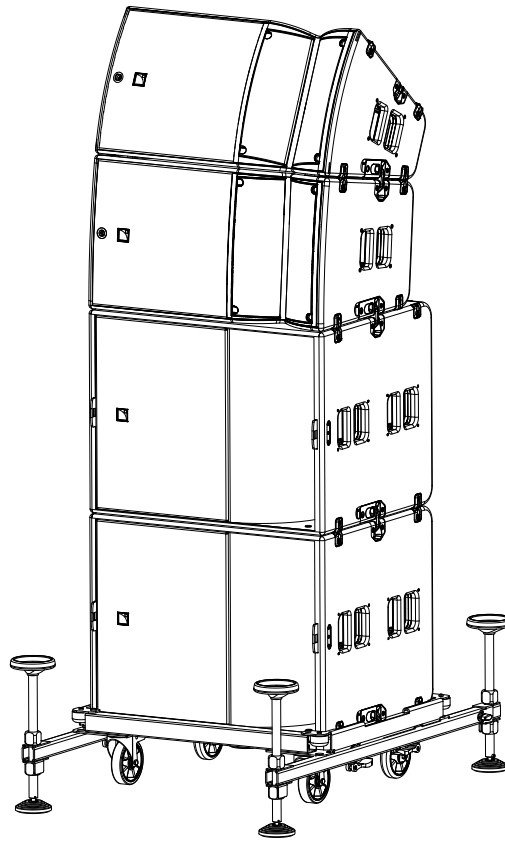

## Storage and handling elements

### KS21-CHARIOT

KS21-CHARIOT is a chariot designed to transport a stack of up to three KS21. It features two rigging arms to secure the lower KS21.

**!** **KS21-CHARIOT is intended for use only with L-Acoustics KS21.**

Use with other equipment may result in instability causing injury.

**!** Do not move or transport more than three enclosures on KS21-CHARIOT.

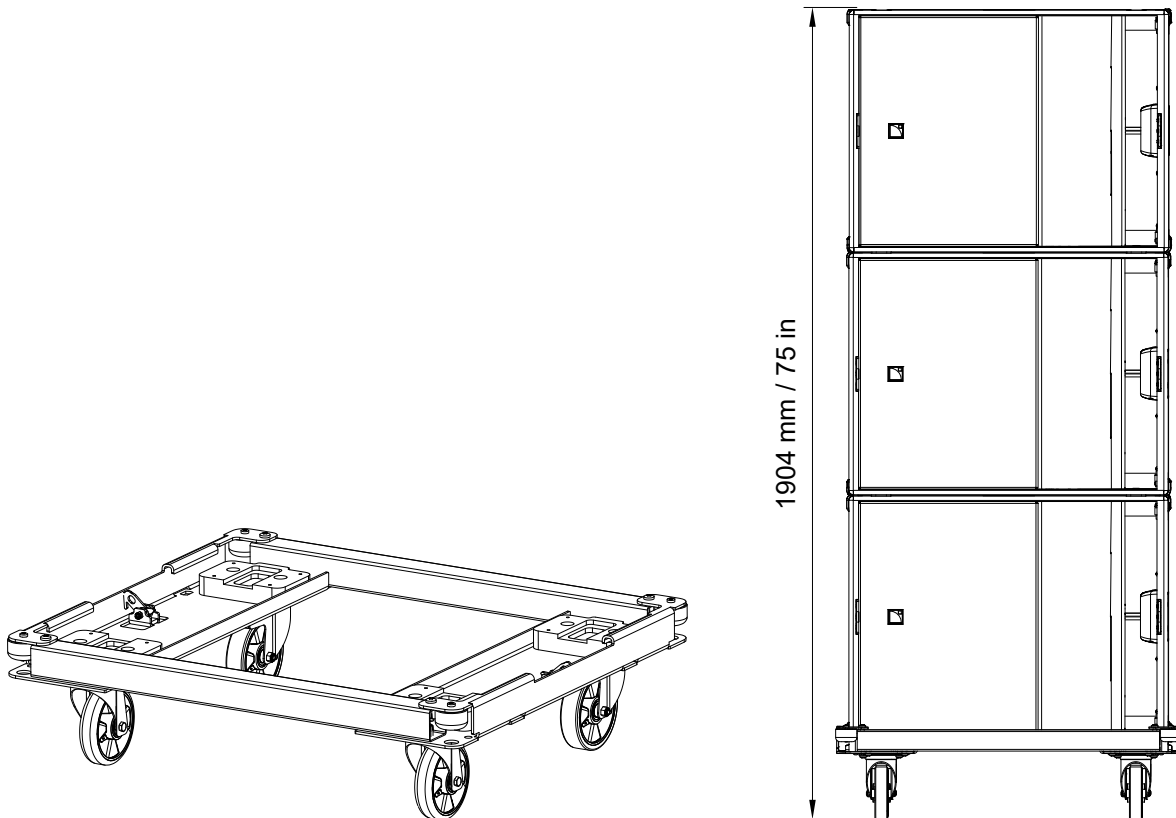

KS21-CHARIOT features two brakes for optimal stability.

**!** **Risk of brake damage**

Do not use the brakes during transportation.

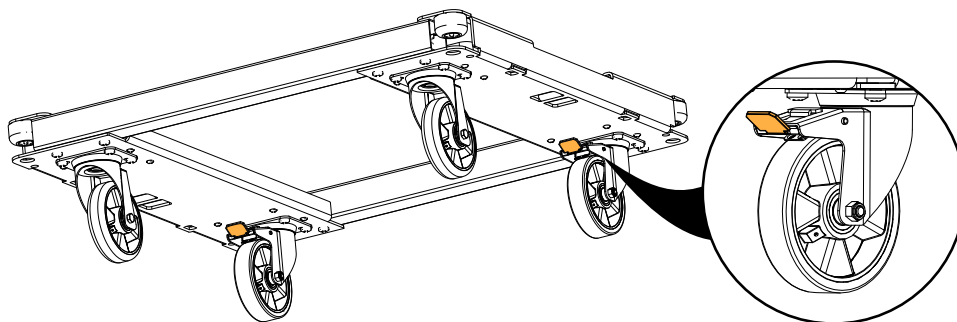

Multiple KS21-CHARIOT can be stacked for storage.

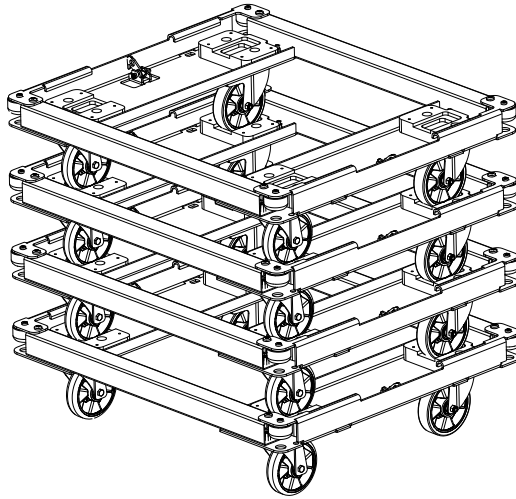

## KS21-PLA

KS21-PLA is a dolly board that can be secured to the front of a KS21 with two spring-loaded pins.



**KS21-PLA is intended for use only with L-Acoustics KS21.**

Use with other equipment may result in instability causing injury.

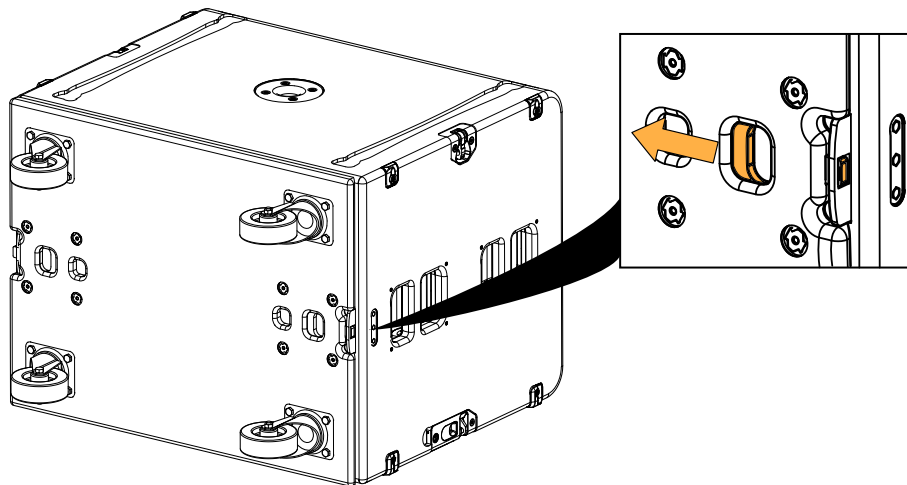

Multiple KS21-PLA can be stacked for storage.



Turn the wheels outwards to stack KS21-PLA.

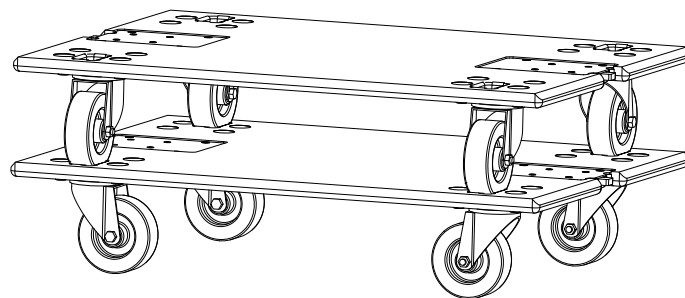

## KS21-COV and KS21-CHARIOTCOV

KS21-COV is an individual cover for KS21 on KS21-PLA. Two flaps provide access to the connector plate.

KS21-CHARIOTCOV is a cover for a stack of two to three KS21 on KS21-CHARIOT.

To fit a stack of two KS21, KS21-CHARIOTCOV must be folded inwards and secured with the integrated velcro straps.

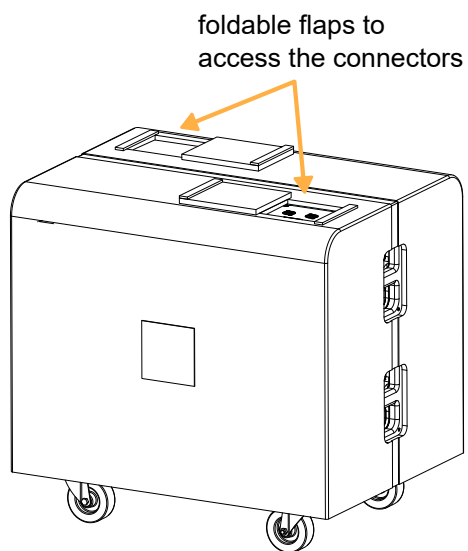

KS21-COV

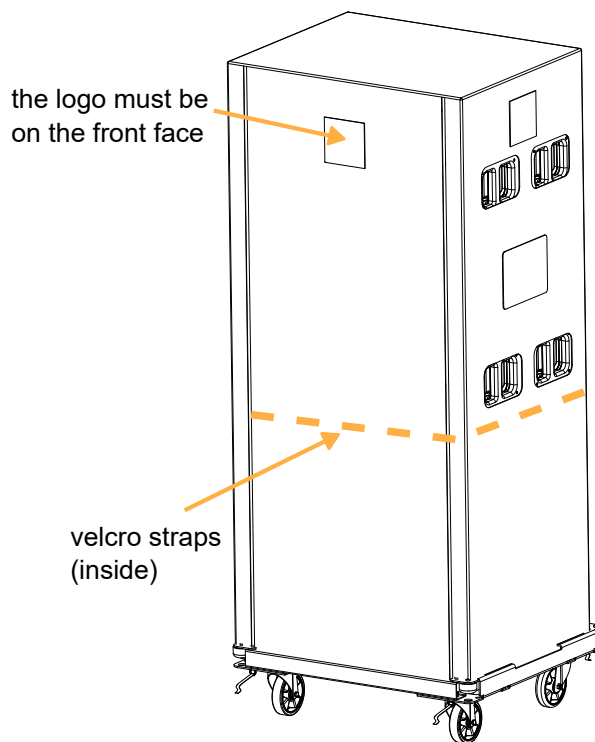

KS21-CHARIOTCOV

# Mechanical safety

## Flown configurations

The KS21 rigging system complies with 2006/42/EC: Machinery Directive. It has been designed following the guidelines of BGV-C1.

2006/42/EC: Machinery Directive specifies a safety factor of 4 against the rupture. The flown deployments described in this manual achieve a safety factor of **4 or more**.

Refer to Soundvision for the safety factor of a specific deployment.

The **safe limit** gives the maximum number of elements for which the safety factor is compliant with the 2006/42/EC: Machinery Directive, within the use defined in this manual and regardless of the other deployment parameters (site angles, inter-enclosure angles, etc.).

The **maximum limit** gives the maximum number of elements for which the safety factor can be compliant with the 2006/42/EC: Machinery Directive, when the other deployment parameters provide the best mechanical conditions.

For mixed arrays refer to your Soundvision model.

## KS21

configuration	rigging accessory	safe limit	maximum limit
Vertical array	A15-BUMP	8	16
Vertical array	A15-RIGBAR	4	

## Other configurations

For other configurations, respect the recommended maximum limit for optimal stability.



### Use safety straps

Always use safety straps on stacked arrays where the enclosures are not connected by the rigging system.  
Always use safety straps on stacked arrays higher than four enclosures.

## KS21

configuration	rigging accessory	maximum / safe limit
Stacked vertical array	No rigging accessory or KS21-OUTRIG (optional)	4
Stacked upright	No rigging accessory	3 
Stacked on chariot	KS21-CHARIOT	3

## Assessing mechanical safety

---



### **Mechanical safety of the rigging system**

Before any installation, always model the system in Soundvision and check the **Mechanical Data** section for any stress warning or stability warning.

In order to assess the actual safety of any array configuration before implementation, refer to the following warnings:



### **Rated working load limit (WLL) is not enough**

The rated WLL is an indication of the element resistance to tensile stress. For complex mechanical systems such as loudspeaker arrays, WLLs cannot be used per se to determine the maximum number of enclosures within an array or to assess the safety of a specific array configuration.

### **Maximum pullback angle**

If a pullback accessory is available, the pullback angle must not exceed a 90° negative site angle.

### **Mechanical modeling with Soundvision**

The working load applied to each linking point, along with the corresponding safety factor, will depend on numerous variables linked to the composition of the array (type and number of enclosures, splay angles) and the implementation of the flying or stacking structure (number and location of flying points, site angle). This cannot be determined without the complex mechanical modeling and calculation offered by Soundvision.

### **Assessing the safety with Soundvision**

The overall safety factor of a specific mechanical configuration always corresponds to the lowest safety factor among all the linking points. Always model the system configuration with the Soundvision software and check the **Mechanical Data** section to identify the weakest link and its corresponding working load. By default, a stress warning will appear when the mechanical safety goes beyond the recommended safety level.

### **Safety of ground-stacked arrays in Soundvision**

For ground-stacked arrays, a distinct stability warning is implemented in Soundvision. It indicates a tipping hazard when the array is not secured to the ground, stage or platform. It is the user's responsibility to secure the array and to ignore the warning.

### **Additional safety for flown arrays**

When flying an array, use available holes to implement a secondary safety.

### **Considerations must be given to unusual conditions**

Soundvision calculations are based on usual environmental conditions. A higher safety factor is recommended with factors such as extreme high or low temperatures, strong wind, prolonged exposition to salt water, etc. Always consult a rigging specialist to adopt safety practices adapted to such a situation.

# Loudspeaker configurations

## KS21 in standard configuration

Deployed in a standard configuration, a KS21 system operates with an omnidirectional directivity pattern over the nominal bandwidth of the KS21 enclosure.

The [KS21\_60] and [KS21\_100] factory presets provide the subwoofer system with an upper frequency limit at 60 Hz and 100 Hz respectively in order to optimize the acoustic coupling with a main full-range system.

The KS21 subwoofer is driven by the LA4X / LA8 / LA12X amplified controller.

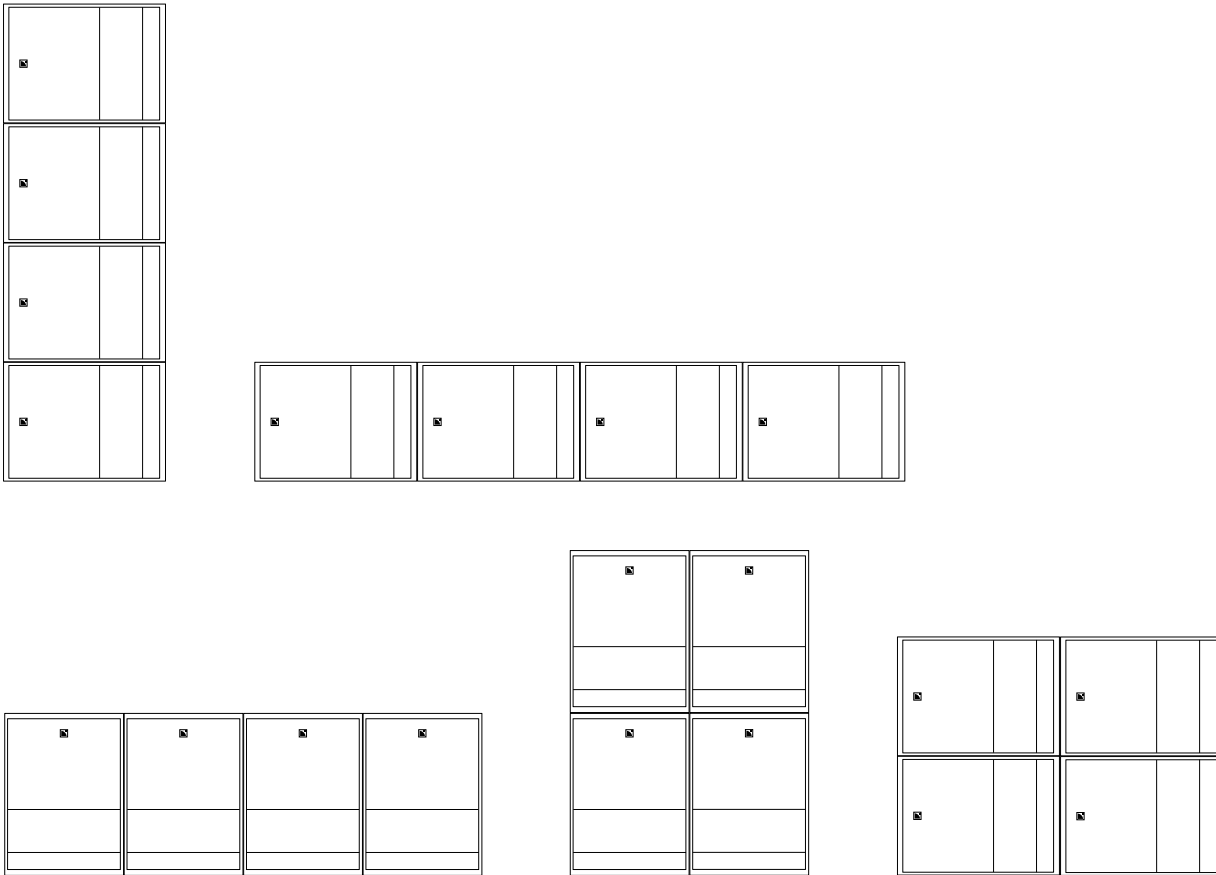

Preset

[KS21\_60]

[KS21\_100]

Low frequency limit

29 Hz

31 Hz



### Delay values

When combining a line source with subwoofers, delays may have to be added to the presets. Refer to the Preset Guide to obtain the pre-alignment delay values.



### Grouping subwoofers

Place the subwoofer enclosures side by side. If not possible, the maximum distance between two adjacent acoustic centers must be 2.8 m or 1.7 m if the upper frequency limit of the subwoofer system is at 60 Hz or 100 Hz, respectively.

## KS21 in cardioid configuration

Deployed in a cardioid configuration, a KS21 system produces a rear SPL rejection. The deployment consists of an array of four KS21 with one element turned towards the rear (reversed). Refer to the **Cardioid Configuration** technical bulletin for more information.

The [KS21\_60\_C] / [KS21\_60\_Cx], and [KS21\_100\_C] / [KS21\_100\_Cx] factory presets provide the subwoofer system with an upper frequency limit at 60 Hz and 100 Hz respectively in order to optimize the acoustic coupling with a main full-range system.

The KS21 subwoofer is driven by the LA4X / LA8 / LA12X amplified controllers.

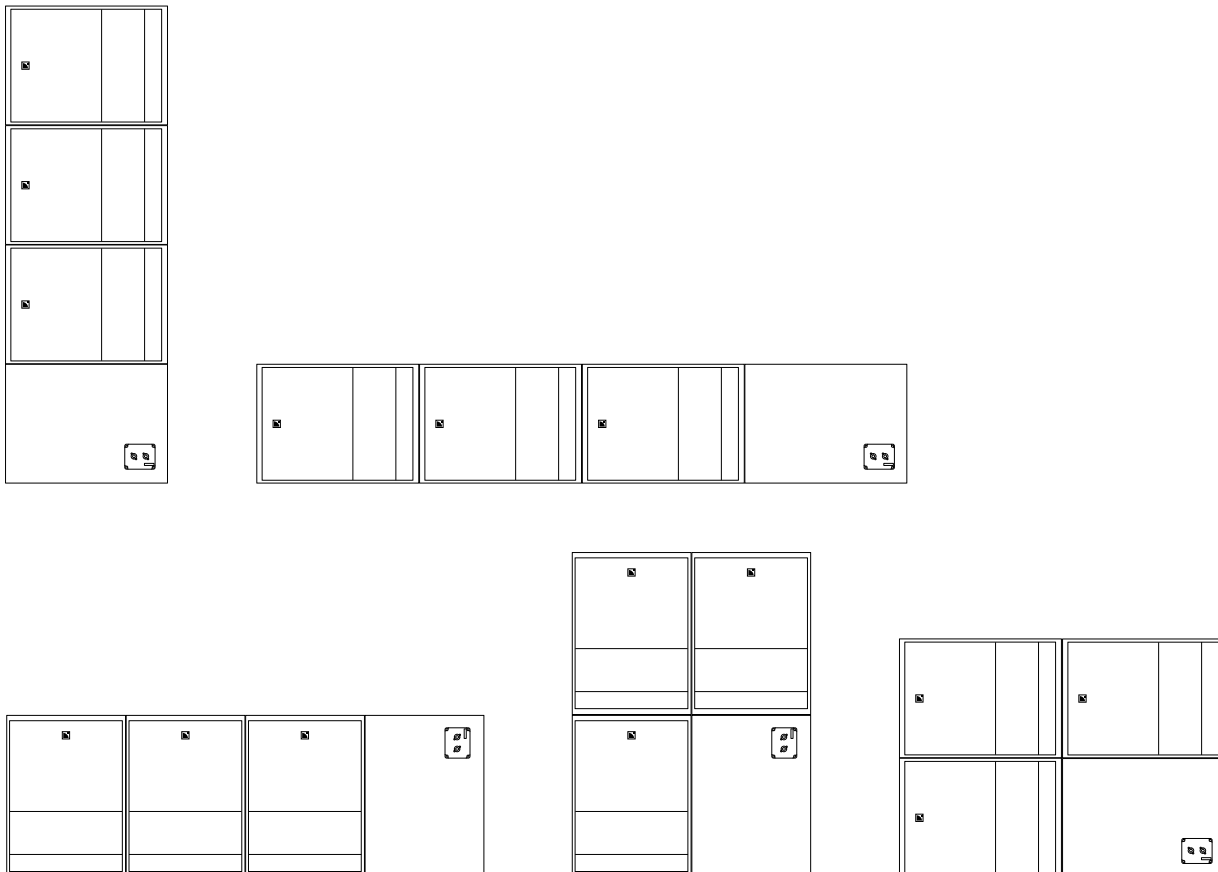

Preset	[KS21_60_C] / [KS21_60_Cx]	[KS21_100_C] / [KS21_100_Cx]
Low frequency limit	29 Hz	31 Hz



### Delay values

When combining a line source with subwoofers, delays may have to be added to the presets. Refer to the Preset Guide to obtain the pre-alignment delay values.



### Grouping subwoofers

Place the subwoofer enclosures side by side. If not possible, the maximum distance between two adjacent acoustic centers must be 2.8 m or 1.7 m if the upper frequency limit of the subwoofer system is at 60 Hz or 100 Hz, respectively.

# Inspection and preventive maintenance

## How to do preventive maintenance

---

Inspect the system before any deployment and after any corrective maintenance operation.

Perform preventive maintenance at least once a year.

Refer to the maintenance manuals for advanced maintenance.

### Rigging and hardware

Perform the [Rigging part inspection](#) (p.29) on each rigging part.

Use the [Mechanical system overview](#) (p.29) to identify critical parts of the system and apply the specific checks described in the [Inspection references](#) (p.35).

Do the [Rigging check](#) (p.42).

If any parts are damaged, order the repair or replacement kits listed in [Inspection references](#) (p.35) and contact your L-Acoustics representative for further instructions.

### Acoustics

Perform the [Enclosure check](#) (p.44).

Perform the [Listening test](#) (p.46) to detect any degradation in sound quality.

If necessary, refer to the [Corrective maintenance](#) (p.58) section for speaker repair kits and maintenance instructions.

## Rigging part inspection

---

### About this task

For critical rigging parts, use the [Inspection references](#) (p.35) for comparison and specific manipulations.

### Prerequisite

Perform the inspection in a well-lit environment.

### Procedure

1. Check that the rigging part is present.
2. If applicable, disassemble the rigging part from the enclosure or the rigging accessory.

Check that the tethers are intact and safely secured.

3. Inspect the part from every side.

Compare with the **reference pictures**.

Check for:

- corrosion
- wear and cracks
- bends and dents
- holes
- missing safety cues
- missing identification labels
- missing or loose fasteners



#### Replacing screws

If a screw is loose, remove and replace it.

Always use the new screws provided in the repair kit.

If no new screw is available, add blue threadlocker before reusing the screw.

Do not apply more than the indicated torque.

4. Check the **geometry** of the part to identify critical deformations.

Place the rigging part on a flat surface or hold a level against it.

5. Check the **moving parts**.

Make sure that the mechanism engages correctly.

### What to do next



If a problem is detected, perform the authorized maintenance operations or contact your L-Acoustics representative.

## Mechanical system overview

---

Critical parts of the lifting chains are highlighted.



The  indicates a visual inspection. The  indicates a functional check.



Perform the [Rigging part inspection](#) (p.29) on critical parts.

For each part, refer to the [Inspection references](#) (p.35).



#### Replacing screws

If a screw is loose, remove and replace it.

Always use the new screws provided in the repair kit.

If no new screw is available, add blue threadlocker before reusing the screw.

Do not apply more than the indicated torque.

## A15 Wide/Focus and KS21 array with A15-BUMP and M-BAR

Shackles (p.35) 

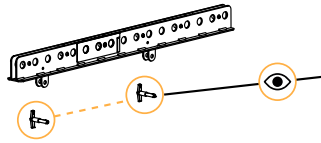
 Ball-locking pins (p.36)

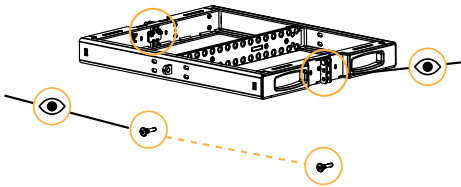
Ball-locking pins (p.36)  the yellow label is present  
the rigging arm can rotate freely

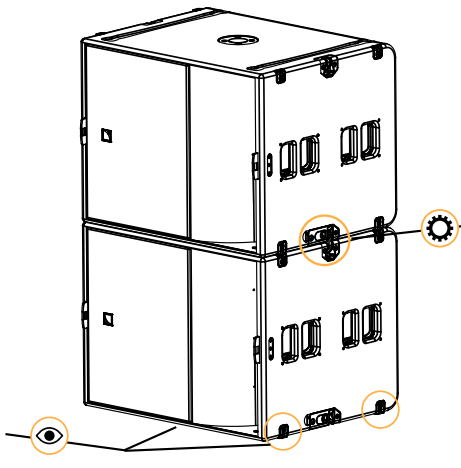
 Rigging check (p.42)

Runners and corner stops (p.38)

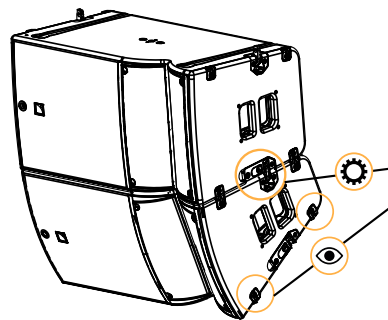
 Rigging check (p.42)  
Runners and corner stops (p.38)

# KS21 array with A15-RIGBAR



Shackles (p.35)

Ball-locking pins (p.36)

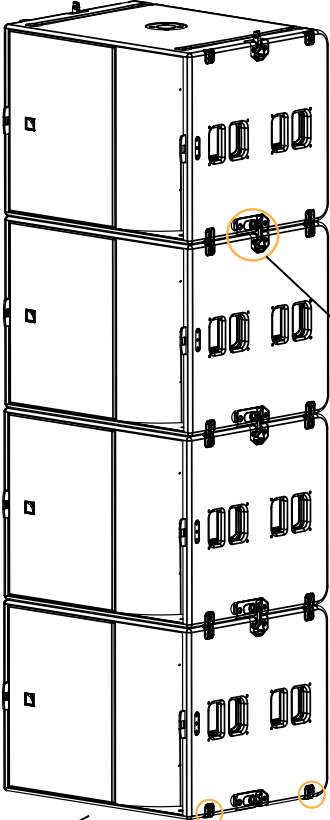
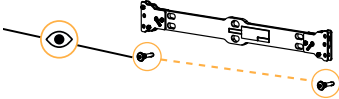

Rigging check (p.42)

Runners and corner stops (p.38)

## A15 Wide/Focus and A-MOUNT pole-mounted on KS21

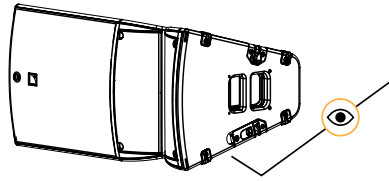

the bottom inserts are not damaged

all screws are tightened  
the angle axis is not bent

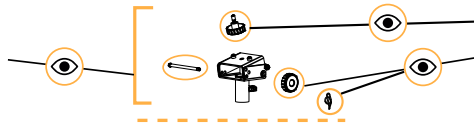
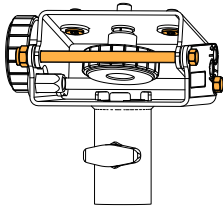
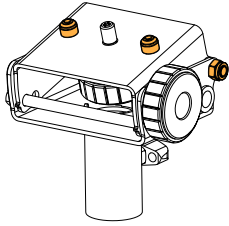

[Threaded knobs \(p.41\)](#)

make sure that either the locking cotter pin or the knob is present



Make sure the pole is compatible with the KS21 pole socket. Refer to [KS21 \(p.12\)](#) for more information.

[Pole-mount socket \(p.40\)](#)

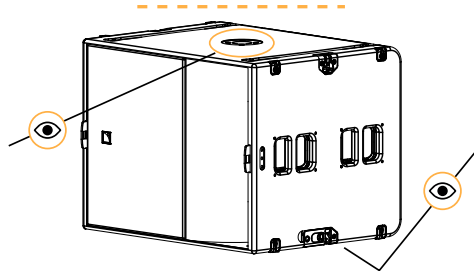

[Runners and corner stops \(p.38\)](#)

# A15 Wide/Focus stacked on A-TILT and KS21 with KS21-OUTRIG

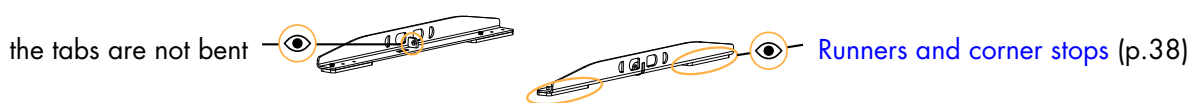
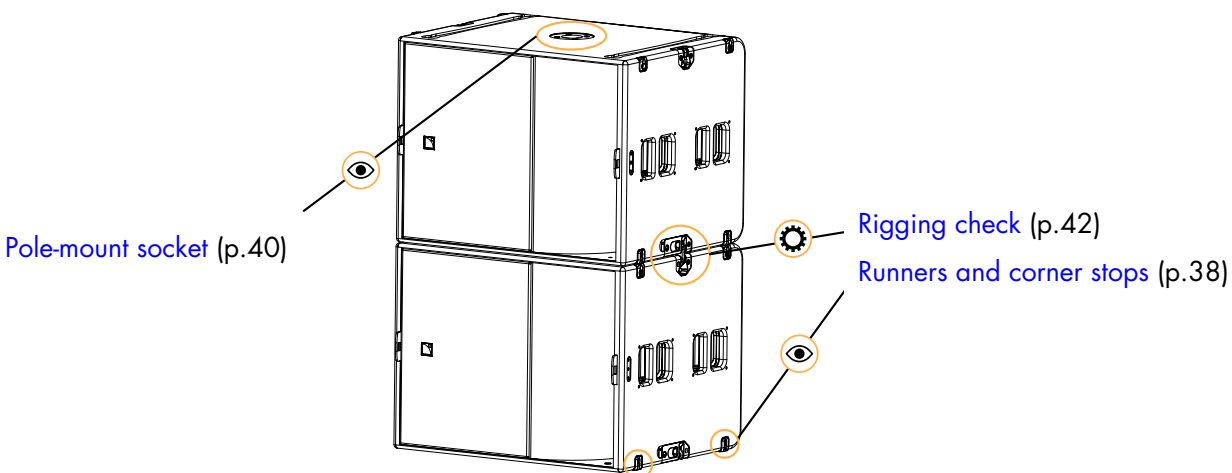
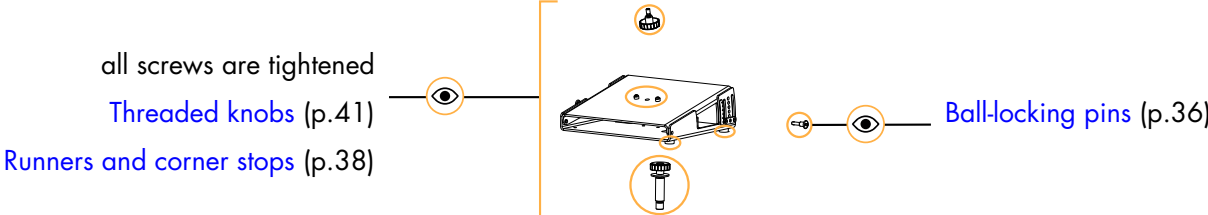
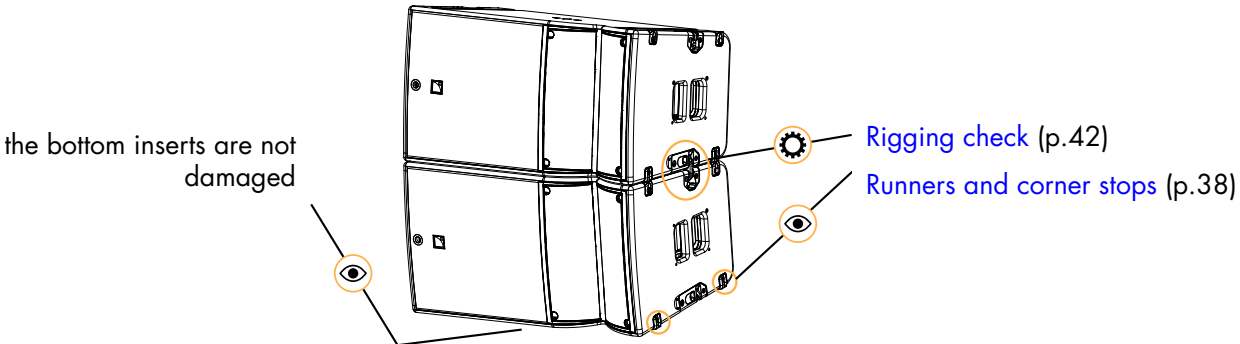

## A15 Wide/Focus stacked on KS21 with K2-CHARIOT and K2-JACK

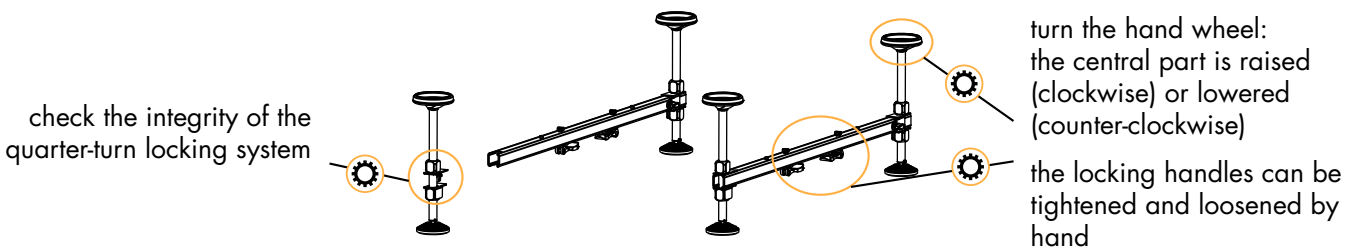
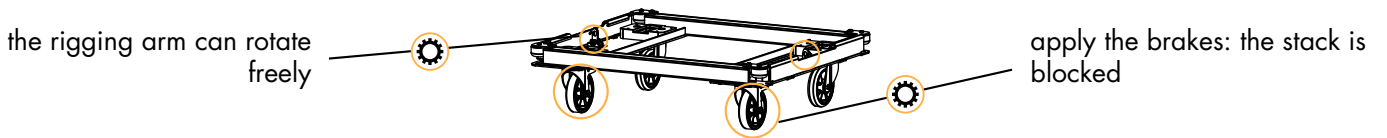
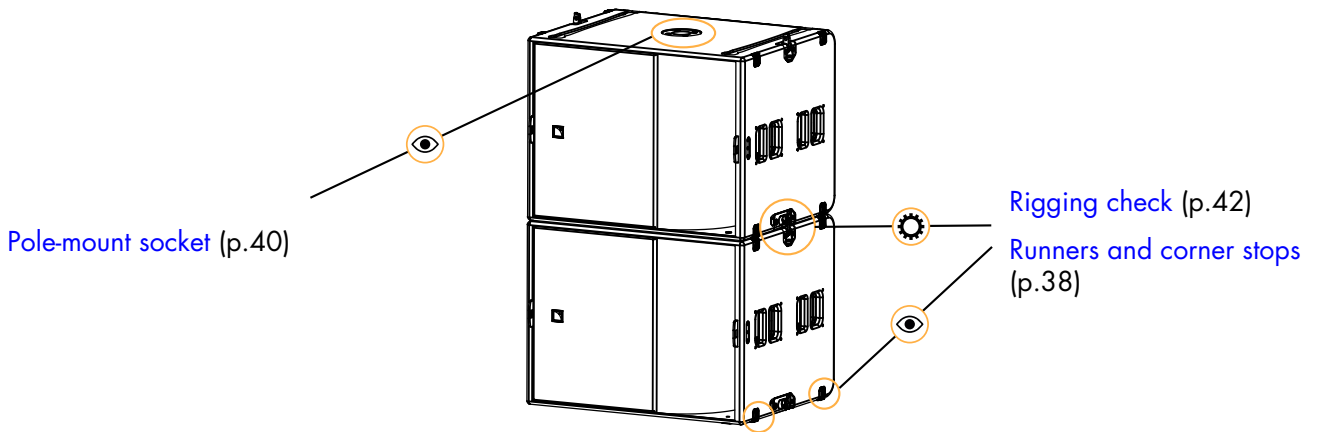
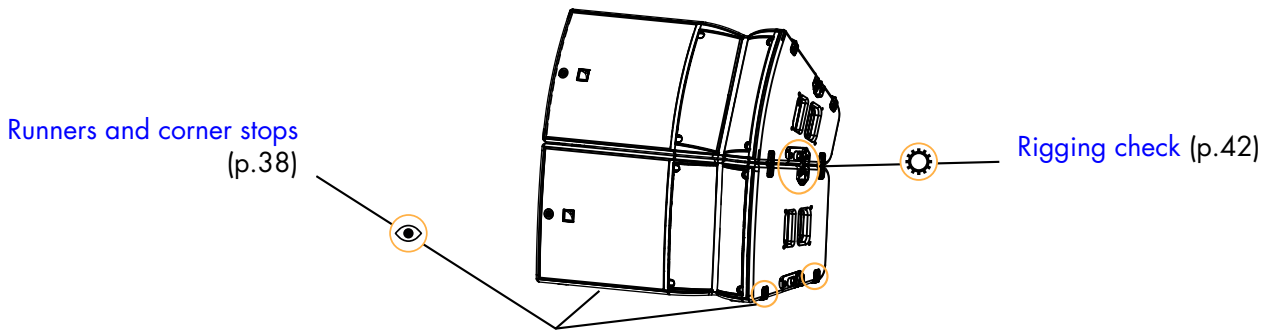

## Inspection references

---

### Shackles

Drive the shackle axis in its lodging. Make sure that the end is flush with the shackle.

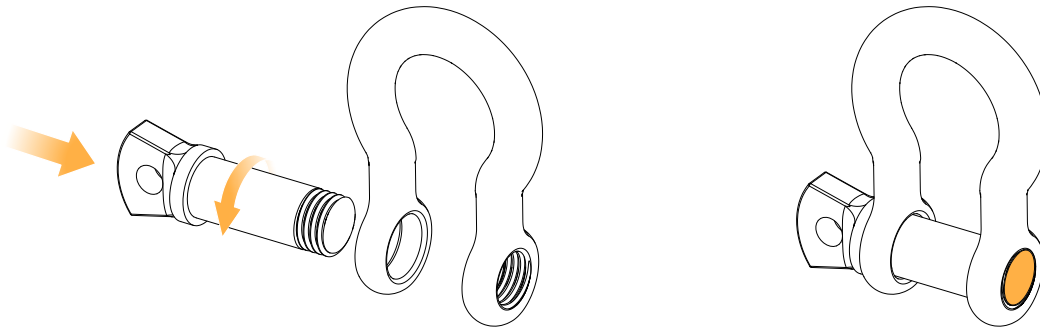

### Repair kits

#### 12 mm shackles

A15-BUMP

KR CAMAN12L (KR bow shackles 12 mm (x2) )

A15-RIGBAR

KR CAMAN12L (KR bow shackles 12 mm (x2) )

### Related tasks

[Rigging part inspection](#) (p.29)

## Ball-locking pins

- Tethers are intact and safely secured.
- Test the ball-locking mechanism (see [Moving parts](#) (p.37)).

### Reference pictures

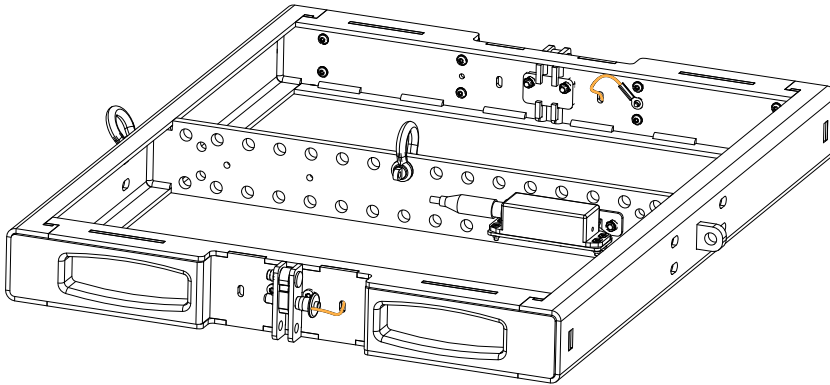

A15-BUMP

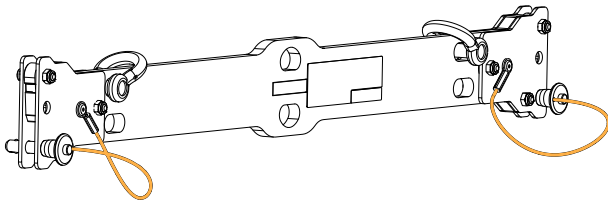

A15-RIGBAR

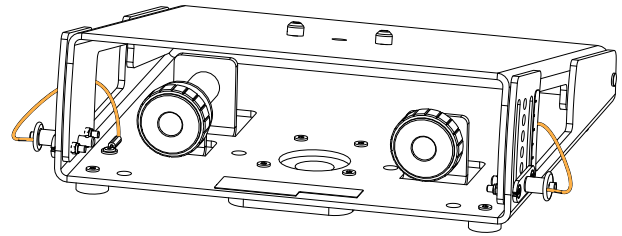

A-TILT

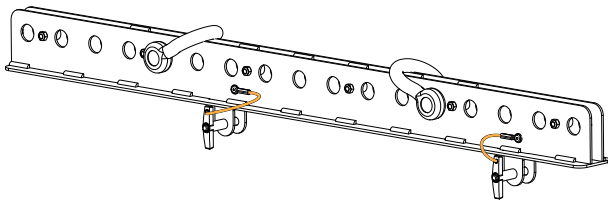

M-BAR

## Moving parts

1. Press the push button. The ball-locking mechanism is retracted.
2. Release the button. The ball-locking mechanism is activated.

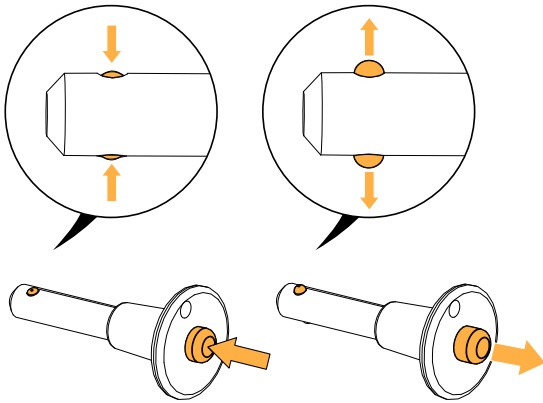

3. Insert the pin in each storage and rigging hole. Pull and rotate the pin. The pin must remain inside the hole.

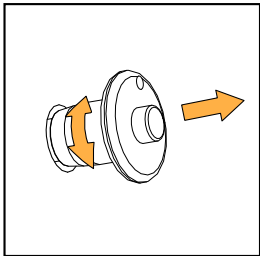

If the pin is inserted in two plates, the ball must pass through both plates and lock the pin in place.

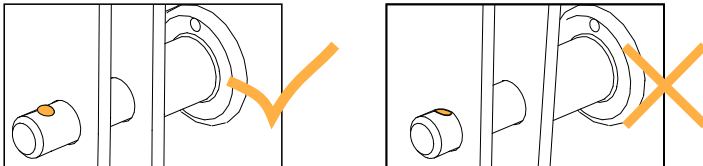

If the check fails, **immediately withdraw the product from use and contact L-Acoustics.**

## Repair kits (KR)

A15-BUMP	KR PIN1394 (Kit 2 x pin 1394 )
A15-RIGBAR	KR PIN1394 (Kit 2 x pin 1394 )
A-TILT	G03461 (KR ball-locking pin A15-LIFT/A-TILT )
M-BAR	KR PIN665 (Kit 10 pins 9.5mm diameter screws & rivets)

## Related tasks

[Rigging part inspection](#) (p.29)

## Runners and corner stops

- Runners are not worn out.
- Screws are tightened.

### Reference pictures

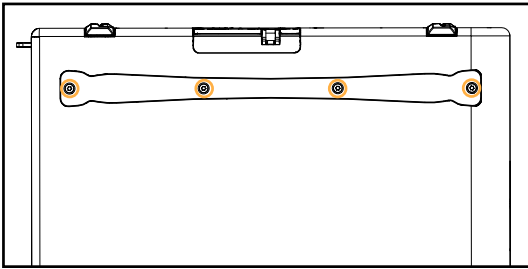

KS21 ground runner

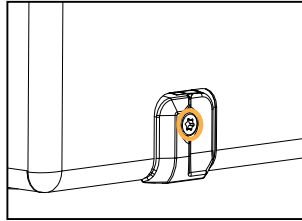

KS21 corner stop

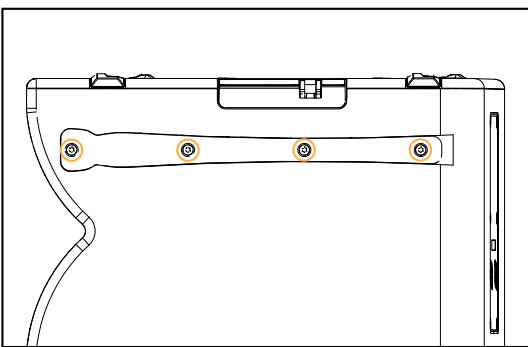

A15 Wide/Focus ground runner

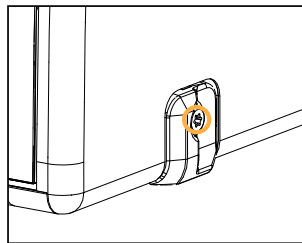

A15 Wide/Focus corner stop

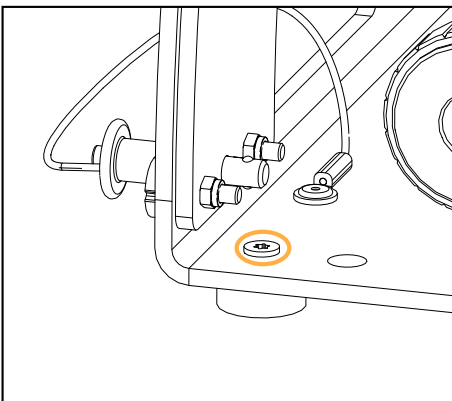

A-TILT runner

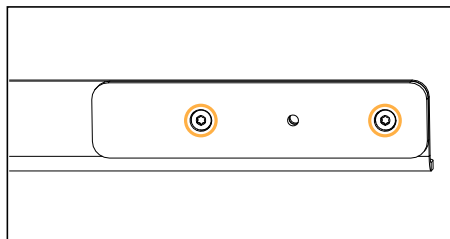

KS21-OUTRIG runner

## Repair kits



**Contact your L-Acoustics representative for repair instructions.**

### Runners

A15 Wide/Focus	G03432 (KR ground runners A15 )
KS21	G03414 (KR ground runners KS21 )
A-TILT	G03468 (KR runners A-TILT )
KS21-OUTRIG	G03478 (KR runners KS21-OUTRIG )

### Corner stops

A15 Wide/Focus / KS21	G03439 (KR corner stops KS21 / A15 )
-----------------------	--------------------------------------

### Screws

A15 Wide/Focus	G03431 (KR screws and fasteners A15 )
KS21	G03413 (KR screws and fasteners KS21 )
A-TILT	G03469 (KR screws and fasteners A-TILT )
KS21-OUTRIG	G03477 (KR screws and fasteners KS21OUTRIG )

### Related tasks

[Rigging part inspection](#) (p.29)

## Pole-mount socket

- Pole-mount socket is not damaged or bent.
- Screws are tightened.
- Socket plug is present.

### Reference pictures

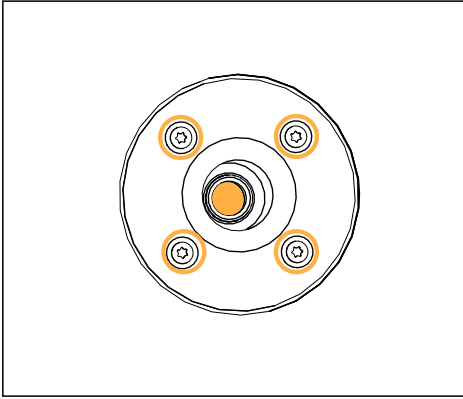

KS21 pole-mount socket

### Repair kits



**Contact your L-Acoustics representative for repair instructions.**

#### Pole-mount socket

KS21

G03415 (KR pole mount with insert )

#### Screws

KS21

G03413 (KR screws and fasteners KS21 )

### Related tasks

[Rigging part inspection](#) (p.29)

## Threaded knobs

- Head part does not have cracks.
- Head part is tightly secured to the body part.
- All washers are present.

### Reference pictures

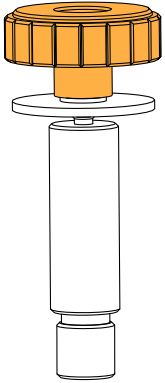

A-TILT  
subwoofer knob

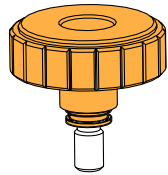

A-TILT and  
A-MOUNT  
enclosure knob

### Repair kits

A-MOUNT

G03471 (KR threaded knob A-TILT )

A-TILT

G03474 (KR threaded knob for pole socket A-TILT )

G03471 (KR threaded knob A-TILT )

### Related tasks

[Rigging part inspection](#) (p.29)

## Rigging check

### About this task

**!** The procedure is described with two KS21 but can be executed identically with two A15 Wide/Focus.

### Procedure

1. Secure one KS21 on top of another one.

**i** Push and slide to unlock the spring-loaded pin.

Connect the rigging systems on both sides.

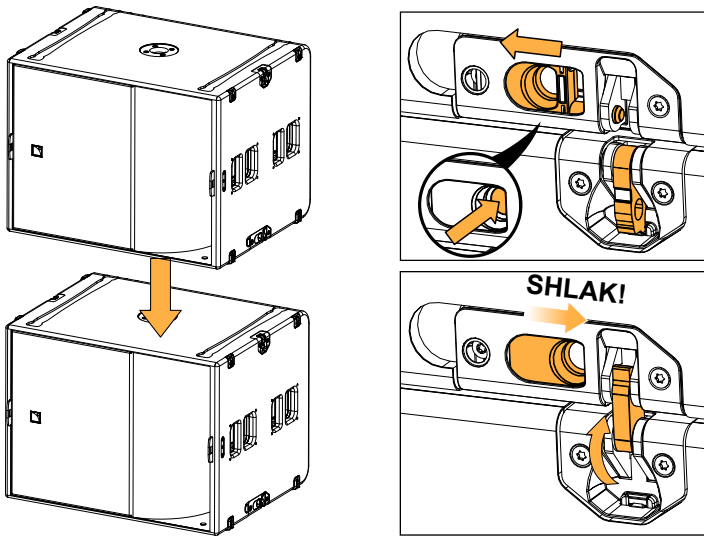

- The rigging arm is removed from its storage position with some resistance.
- When pushing and sliding the mechanism, the spring-loaded pin is retracted with some resistance.
- Upon release, the spring-loaded pin quickly returns to its initial position.
- The yellow labels on the rigging arm and on the spring-loaded pin are visible when the rigging system is not locked.

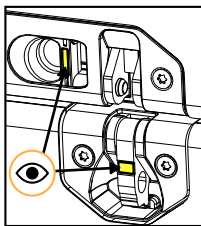

not locked

- No yellow labels are visible when the rigging system is locked.

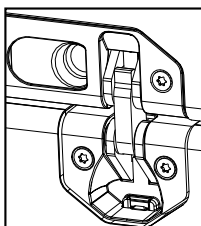

locked

2. Hold the top enclosure by the handles and shake the assembly.  
The two enclosures remain attached.
3. Unlock the rigging system on both sides.

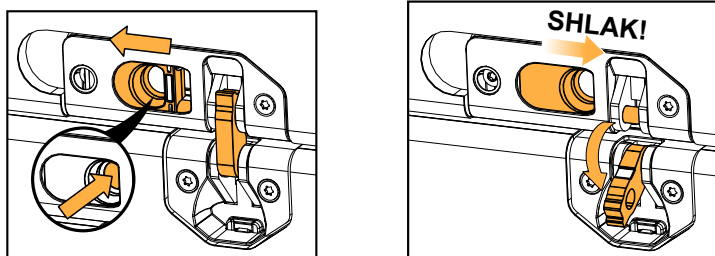

4. Switch the enclosures and repeat the procedure.

## Acoustical check

---

### Enclosure check

-  **This feature is available on:**  
 LA4X  
 LA12X

ENCLOSURE CHECK measures impedance at the reference frequencies for the connected loudspeaker family. The measured impedance is compared to the expected range allowing for fast detection of loudspeakers presenting circuit continuity issues.

 The results can be used for preliminary diagnosis but cannot replace a comprehensive quality control.

### Prerequisite

-  **ENCLOSURE CHECK measurements can only be reliable if the following requirements are met:**

Environment and temperature:

- Ambient temperature must be comprised between 0 °C / 32 °F and 40 °C / 104 °F. Ideal temperature is 20 °C / 68 °F.
- Enclosures must be at room temperature. If warm from a recent high level use or recently moved from a cold environment, let the loudspeakers reach room temperature before starting.

Enclosures:

- Enclosures must be included in the embedded factory preset library.
- Enclosures must be in nominal operating conditions:
  - Remove covers or dollies obstructing the loudspeakers or the vents.
  - Check for obvious physical damage or air leak: visually inspect the grill, gasket, cabinet, and connector plate for loose, missing or damaged parts.

Connection:

- Use only 10 m / 30 ft 4 mm<sup>2</sup> / AWG 11 speaker cables.
- Do not connect enclosures in parallel.

Amplified controllers:

- LA4X must run at least firmware version 1.1.0.
- LA4X load sensors must be calibrated. Refer to the **Load Sensor Calibration Tool** technical bulletin for more information.
- LA4X must warm up for at least 10 minutes after power up. Do not power off, reboot or switch to standby mode to avoid resetting the countdown.
- Load a preset corresponding to the connected loudspeaker's family. Presets from the user memories may be used on condition they are made of presets supported in the embedded factory preset library.

### Procedure

1. Power up the amplified controller. Let LA4X warm up for at least 10 minutes.
2. Connect the loudspeaker enclosures to the amplified controller.
3. Load a preset from or built from the embedded library corresponding to the connected loudspeaker family.
4. On the amplified controller, use the encoder wheel to select **MONITORING & INFO**. Press the OK key or the encoder wheel to validate.
5. Use the encoder wheel to select **ENCLOSURE CHECK**.



#### **Beware of sound levels.**

Although the sound pressure levels generated for the ENCLOSURE CHECK are moderate, do not stay within close proximity of the loudspeakers and consider wearing ear protection.

6. Press the OK key or the encoder wheel to launch the ENCLOSURE CHECK.

The amplified controller generates short sinusoidal signals simultaneously for each connected output.

The amplified controller displays the results for each output.

7. Depending on the displayed results, follow the instructions in the table.

result	interpretation	instructions
OK	measured impedance is within expected range	enclosure is in working order electrically
?	unsupported preset family	only supported enclosures should be tested
NC	Not Connected	if cables are connected: <b>a.</b> inspect the cables and connections <b>b.</b> go to step 8 (p.45)
NOK	measured impedance is not within expected range	<b>a.</b> check that all the prerequisites are met, in particular that the loaded preset corresponds to the connected speaker's family <b>b.</b> inspect the cables and connections <b>c.</b> go to step 8 (p.45)
UNDEF	measured impedance is undefined	

8. Under NC, NOK and UNDEF results, press and hold the corresponding OUT key.

The amplified controller displays:

- the tested frequencies,
- information on the measured impedance:
  - OPEN for open circuit (found in NC results),
  - SHORT for short circuit (found in NOK results), or
  - a percentage of variation from the expected range (found in NOK and UNDEF results)
- the number of operational transducers out of the total



Low variations from the expected range are acceptable: displayed percentage can be different from 0 and all transducers considered operational.

## Listening test

### Procedure

1. Load the preset on an LA4X / LA8 / LA12X amplified controller.
2. Connect a sinus generator to the amplified controller.



#### **Risk of hearing damage**

Set a low sound level to start and use ear protection to adjust before testing.

3. Scan the bandwidth focusing on the usable range.  
The sound should remain pure and free of unwanted noise.

### Troubleshooting for LF speakers

One or more LF speaker produces distorted, buzzing, rubbing, clicking, muffled or weak sound.

#### Possible causes

- The screws are not tightened with the appropriate torque.
- There is an air leak in the gasket.
- There is dust on the cone.
- The cone is damaged.
- The surround is torn or delaminated.
- The voice coil or the spider is damaged.

#### Procedure

1. Visually inspect the speaker and the cables.  
If any damage is visible, replace the speaker.
2. Carefully clean the speaker with a dry cloth.
3. Perform the reassembly procedure.  
Replace the speaker gasket and the screws.  
Apply the recommended torque.
4. Repeat the listening test.  
If the problem persists, replace the speaker.

# Rigging procedures

## Flying

### Flying a vertical array with A15-BUMP/A15-RIGBAR

<b>Type of deployment</b>	flown array
<b>Rigging accessory</b>	A15-BUMP/A15-RIGBAR 2 x Ø12 mm shackle WLL 1 t (provided)
<b>Min number of operators</b>	2



#### Risk of falling objects

Verify that no unattached items remain on the product or assembly.



#### Secondary safety

Use available holes on the rigging accessories to implement a secondary safety.

## Assembly

### Procedure

1. Prepare a stack of KS21.

Connect each enclosure on both sides before adding the new one.

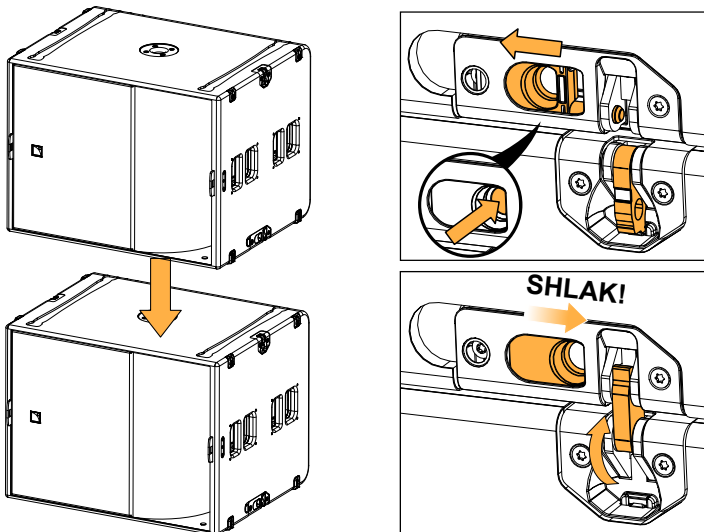

**2. Secure A15-BUMP or A15-RIGBAR on top of the array.**

**A15-BUMP**

Connect A15-BUMP to the top KS21 on both sides.

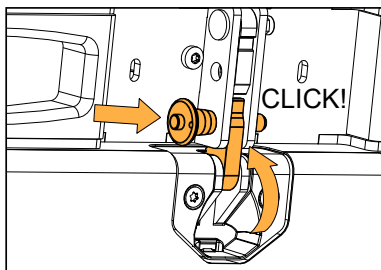
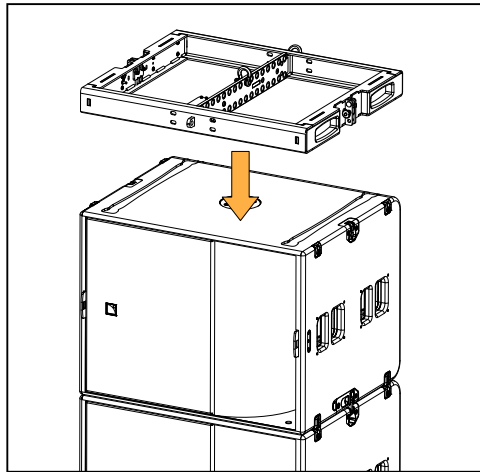

**A15-RIGBAR**

Connect A15-RIGBAR to the top KS21 on both sides.

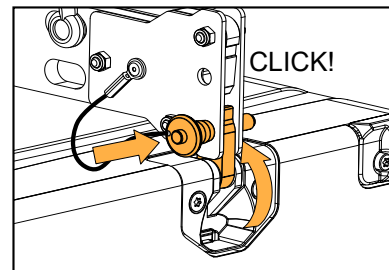
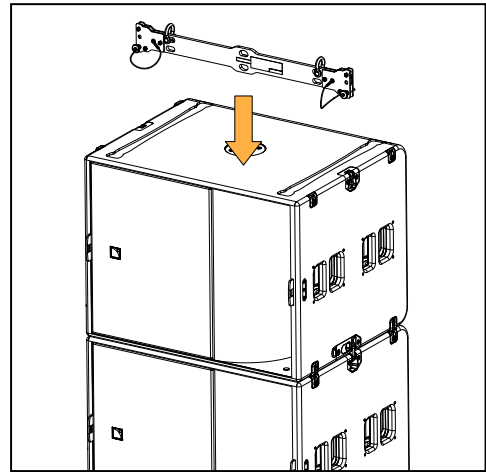

**Final check**

Visually check that no yellow labels are visible.  
Manually check that all linking points are secured.

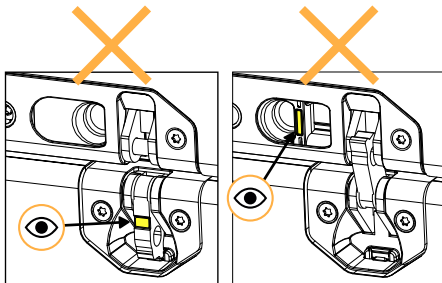

**3. Select the pickup point and raise the array.**

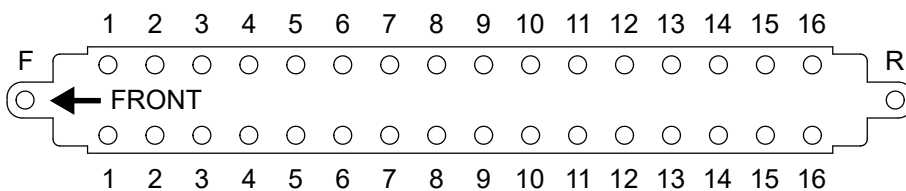

4. Add additional enclosures under the array.
  - a) Lower the array onto a KS21 or a stack of KS21 on KS21-CHARIOT.  
Align the runners and the tracks.

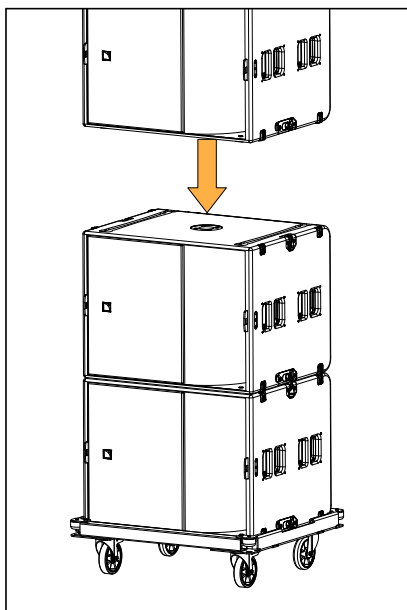

- b) Connect the enclosures on both sides.

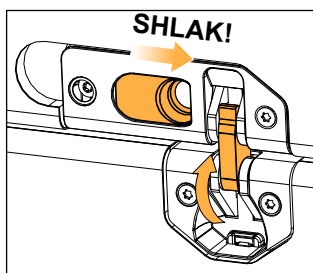
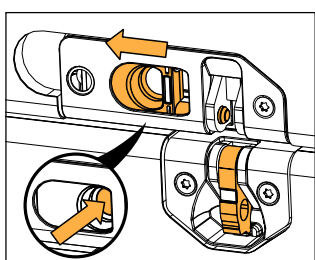

- c) Unlock the KS21-CHARIOT rigging arms.



**Final check**

Visually check that no yellow labels are visible.  
Manually check that all linking points are secured.

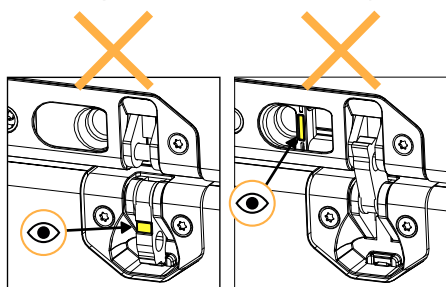

5. Raise the array.

## Disassembly

### Removing a stack of KS21

#### Procedure

1. Position a KS21-CHARIOT under the array.

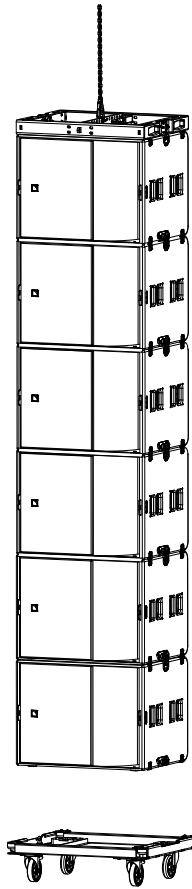

#### Prepare KS21-CHARIOT

Make sure the KS21-CHARIOT brakes are not engaged.  
Make sure the KS21-CHARIOT rigging arms are in the open position.

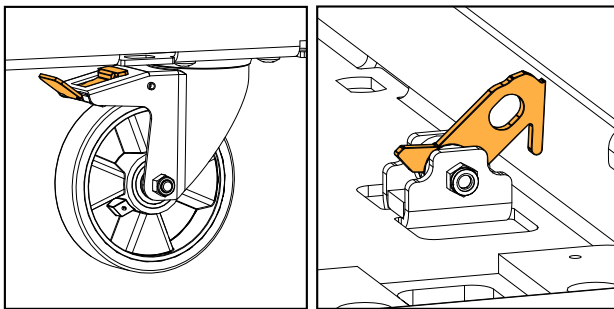

Proceed slowly when lowering the array.

2. Lower the array until it rests on KS21-CHARIOT.

- Secure the bottom enclosure to KS21-CHARIOT.

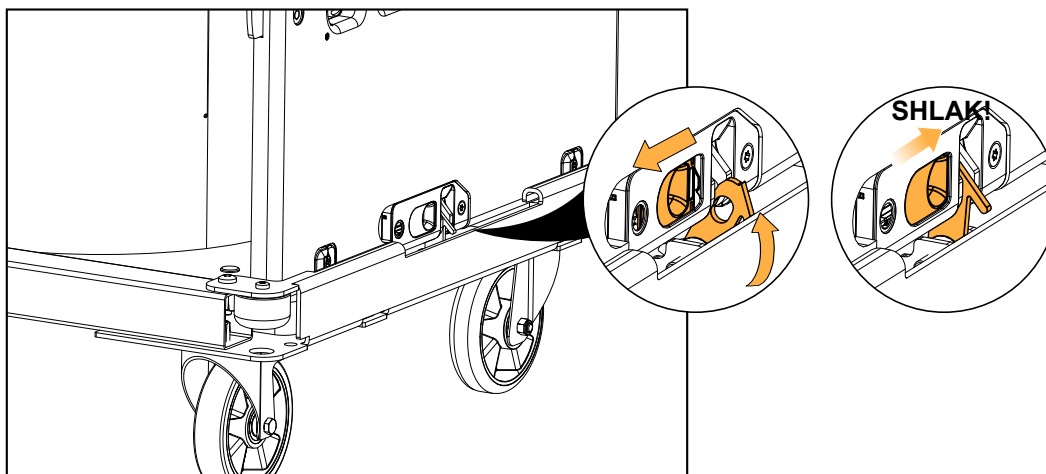

- Disconnect a stack from the array on both sides.

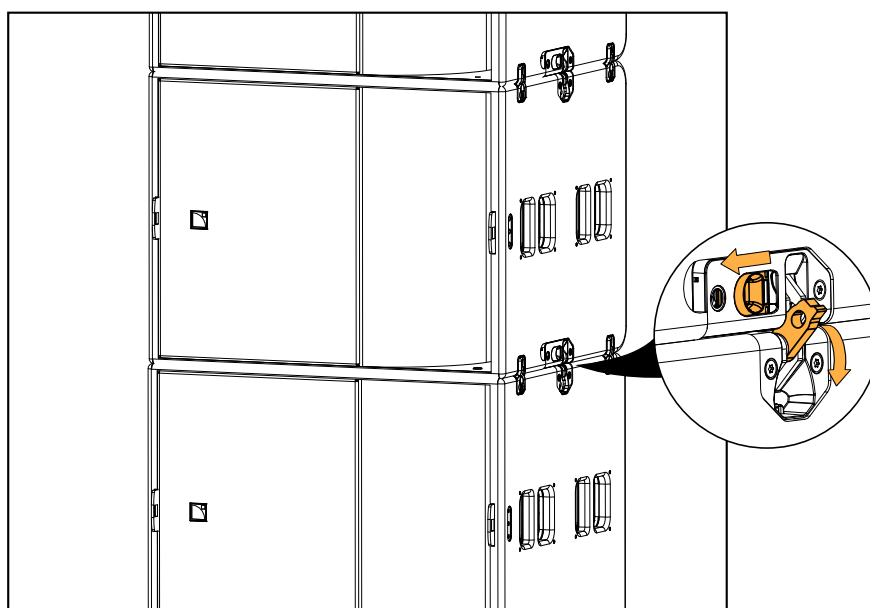

Make sure both linking points are disconnected before lifting the array.

- Lift the assembly and put the stack aside.
- Repeat the procedure.

## Stacking

### Stacking KS21 on KS21-CHARIOT

<b>Type of deployment</b>	stacked array
<b>Rigging accessory</b>	KS21-CHARIOT
<b>Min number of operators</b>	2

**⚠ Risk of falling objects**  
 Verify that no unattached items remain on the product or assembly.

#### Assembly

#### Procedure

1. Engage both brakes on KS21-CHARIOT.

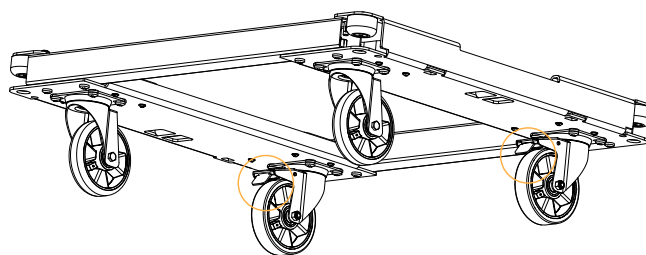

2. Place KS21 on KS21-CHARIOT and connect the two elements on both sides.

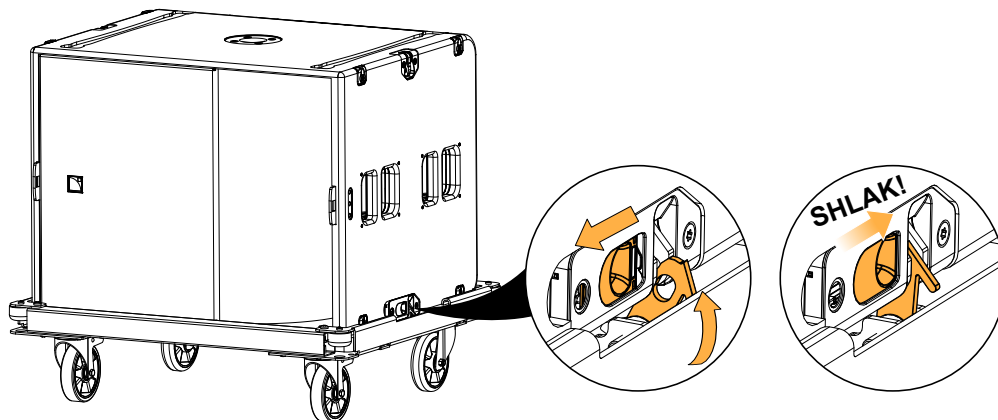

3. Secure another KS21 on the assembly.

Align the runners with the tracks.

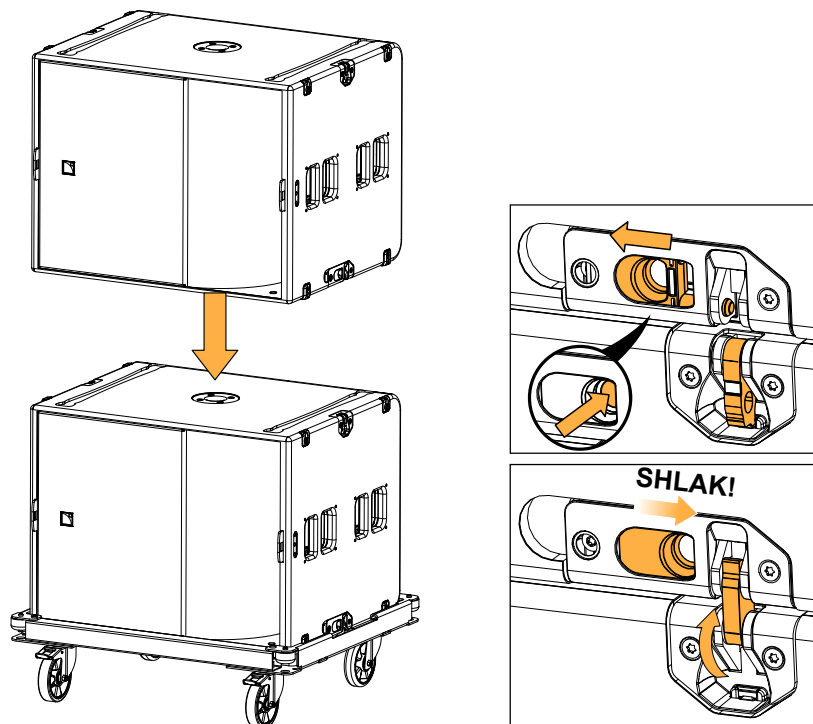

4. Repeat until the stack is complete.



#### Final check

Visually check that no yellow labels are visible.

Manually check that all linking points are secured.

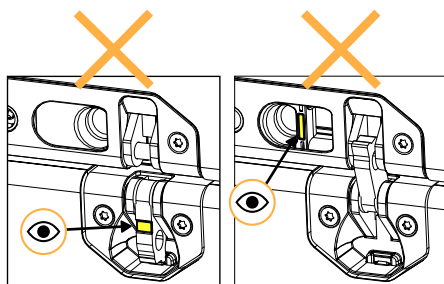

5. Disengage the brakes and position the stack at its final position.

6. Block the stack using both brakes.

## Attaching K2-JACK stabilizers to KS21-CHARIOT

<b>Type of deployment</b>	stacked array
<b>Rigging accessory</b>	K2-JACK KS21-CHARIOT
<b>Min number of operators</b>	1

### Assembly

#### Procedure

1. Attach the K2-JACK bars to KS21-CHARIOT on each side.
  - a) Open the locking handles to insert the studs.

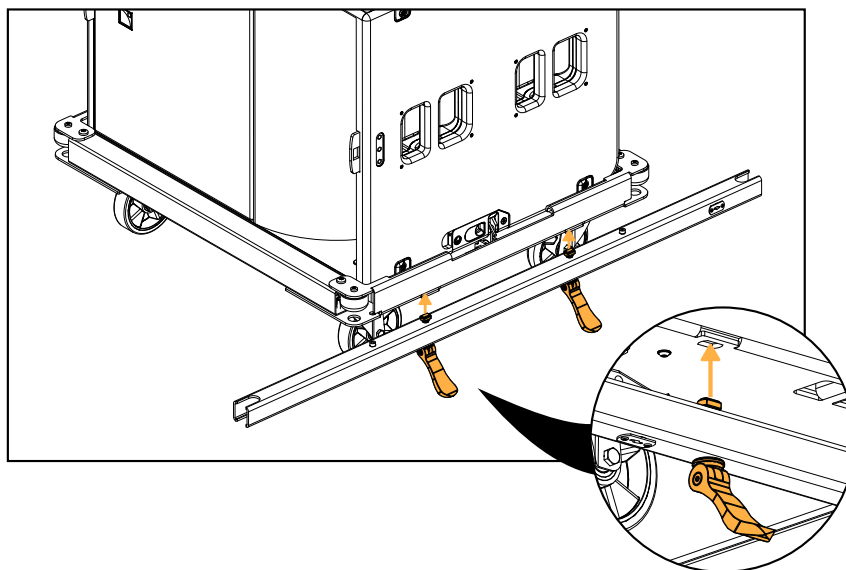

- b) Raise and turn the locking handles to secure the bars.

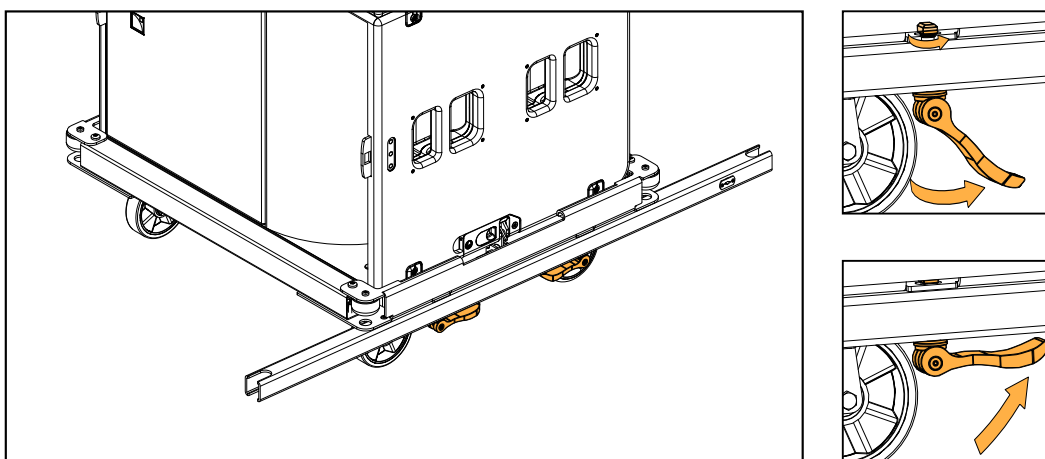

- 2.** On each K2-JACK foot, rotate the wheel counter-clockwise until the central part is close to the base.

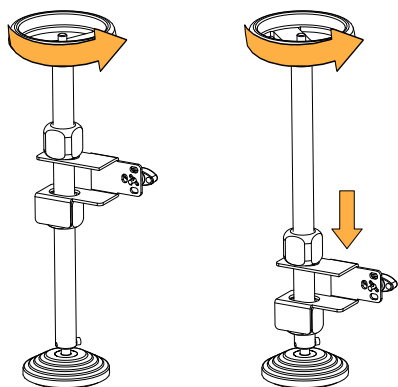

- 3.** Attach the feet to the bar.

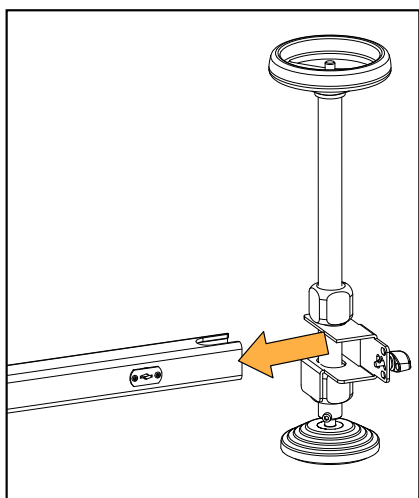

Insert the feet at both ends of the bar.

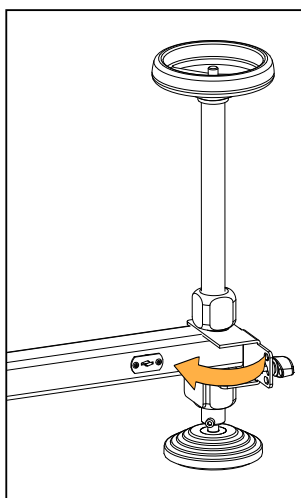

Pivot the central part so that it comes in contact with the bar.

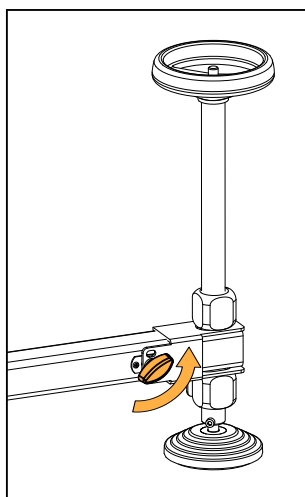

Lock the feet in position by giving a quarter-turn to the locking system.

**4.** Rotate the wheels clockwise to raise the array.

 Stop raising the stack as soon as the wheels get off the ground.

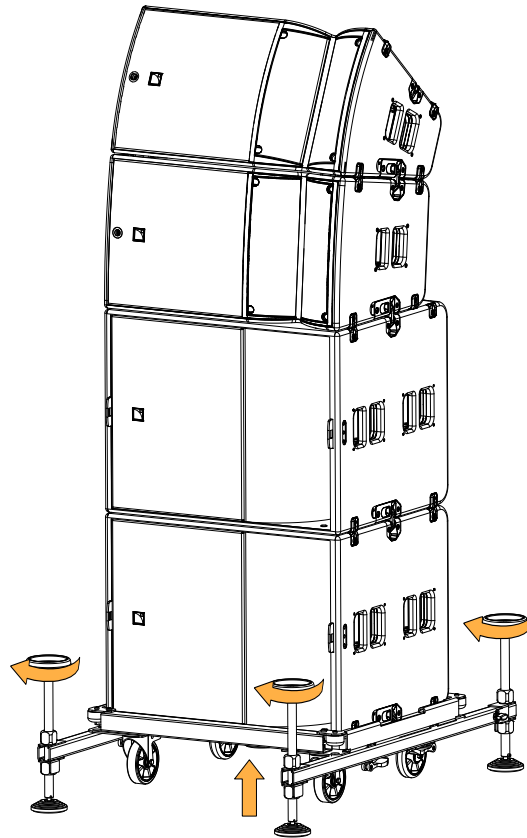

# Connection to LA amplified controllers

## Enclosure drive capacity per amplified controller

Make sure the total number of connected enclosures does not exceed the maximum number of enclosures per controller (refer to the footnotes).

	LA4X	LA8	LA12X
	per output <sup>*</sup> / total	per output <sup>*</sup> / total	per output <sup>*</sup> / total
KS21	1 / 4	2 / 6 <sup>**</sup>	2 / 8

## Cabling schemes for KS21

Refer to the cabling schemes to connect the enclosures to different types of output connectors.

### One-channel speakON output

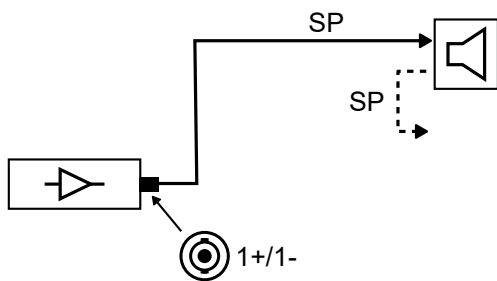

### Two-channel speakON output

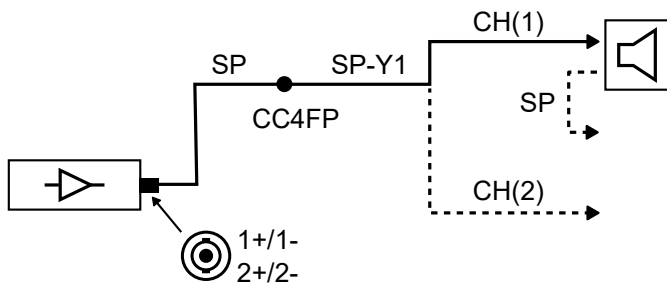

### Four-channel CA-COM output

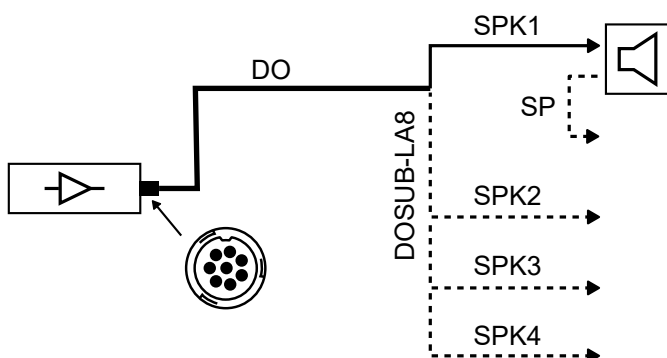

\* For passive loudspeakers, the value corresponds to the number of enclosures in parallel on the output. For active loudspeakers, the value corresponds to the number of sections in parallel on the output.

\*\* LA8 can drive up to two KS21 per output, but no more than six per controller at high level.

## Corrective maintenance

### KS21 exploded view

---

In order to operate, follow the order outlined here. Each assembly refers to the corresponding D/R procedure and the necessary repair kit.

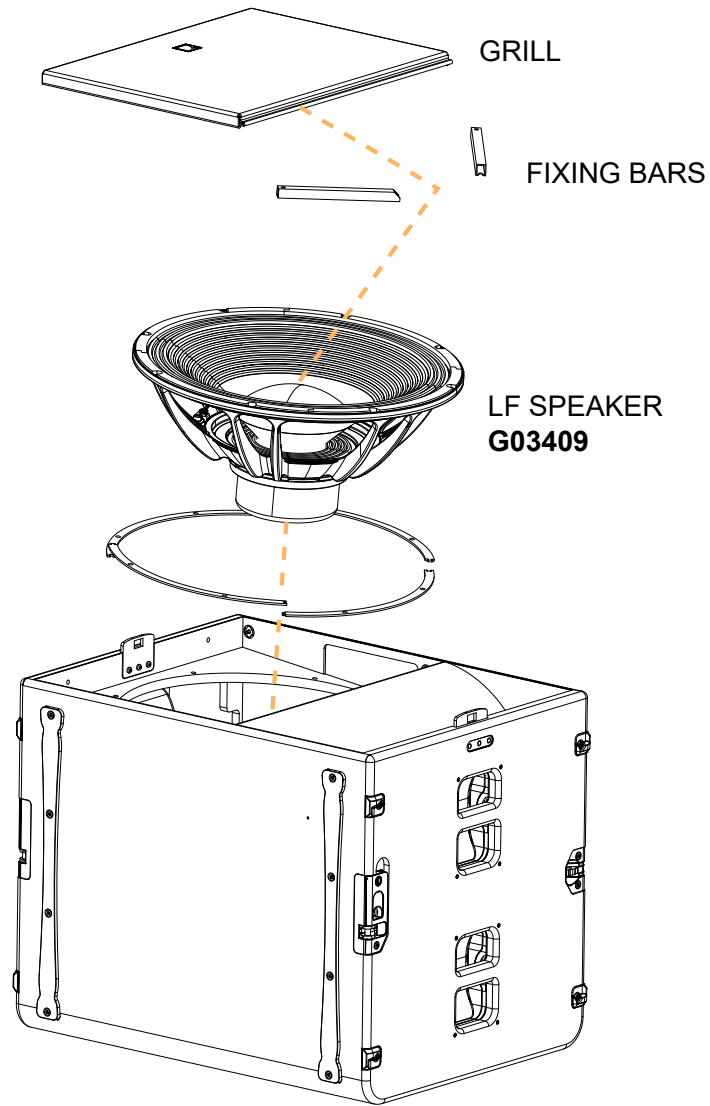

## D/R - Grill

---

### Tools

- torque screwdriver
- T30 Torx bit

### Repair kit

#### G03409

KR loudspeaker 21 KS21

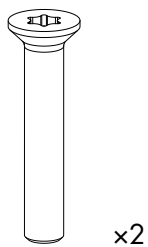

S221

M6x35 Torx

### Exploded view

-  For safety reasons, always use the new screws and spare parts provided in the KR.  
If no new screws are available, use blue threadlocker.

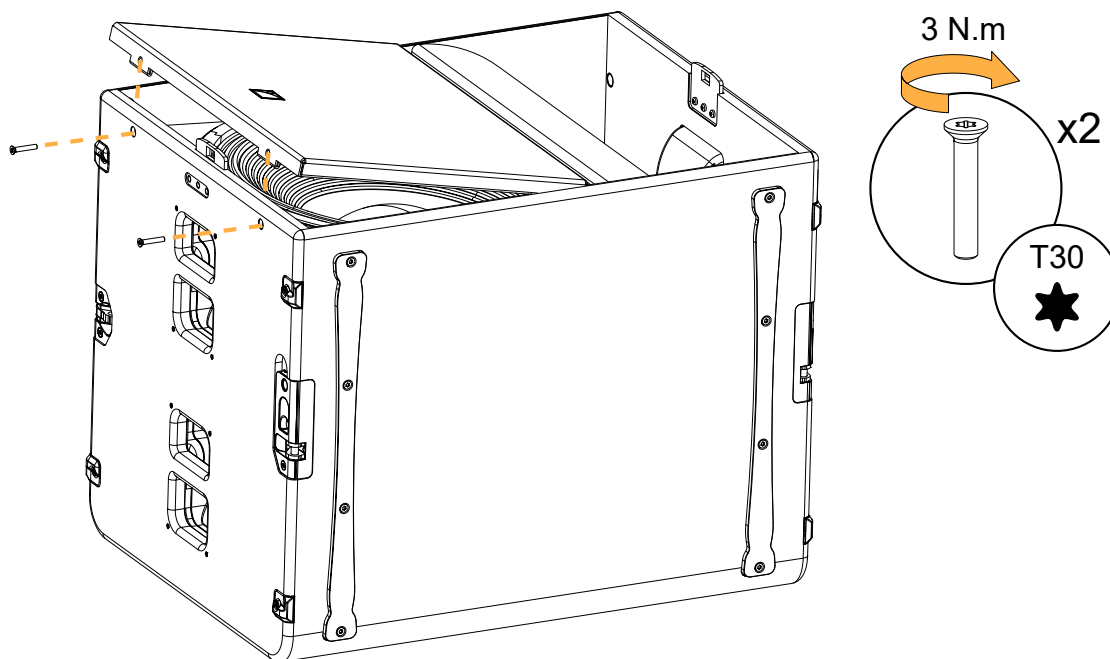

## D/R - Fixing bars

### Tools

- torque screwdriver
- T30 Torx bit

### Repair kit

#### G03409

KR loudspeaker 21 KS21

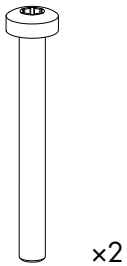

S253

M6 x 55 Torx

### Prerequisite

Grill removed.

See [Grill](#) (p.59).

### Exploded view

- ! For safety reasons, always use the new screws and spare parts provided in the KR.  
If no new screws are available, use blue threadlocker.

Slide the fixing bars under the vent panel to attach them to the studs, then secure them with the screws.

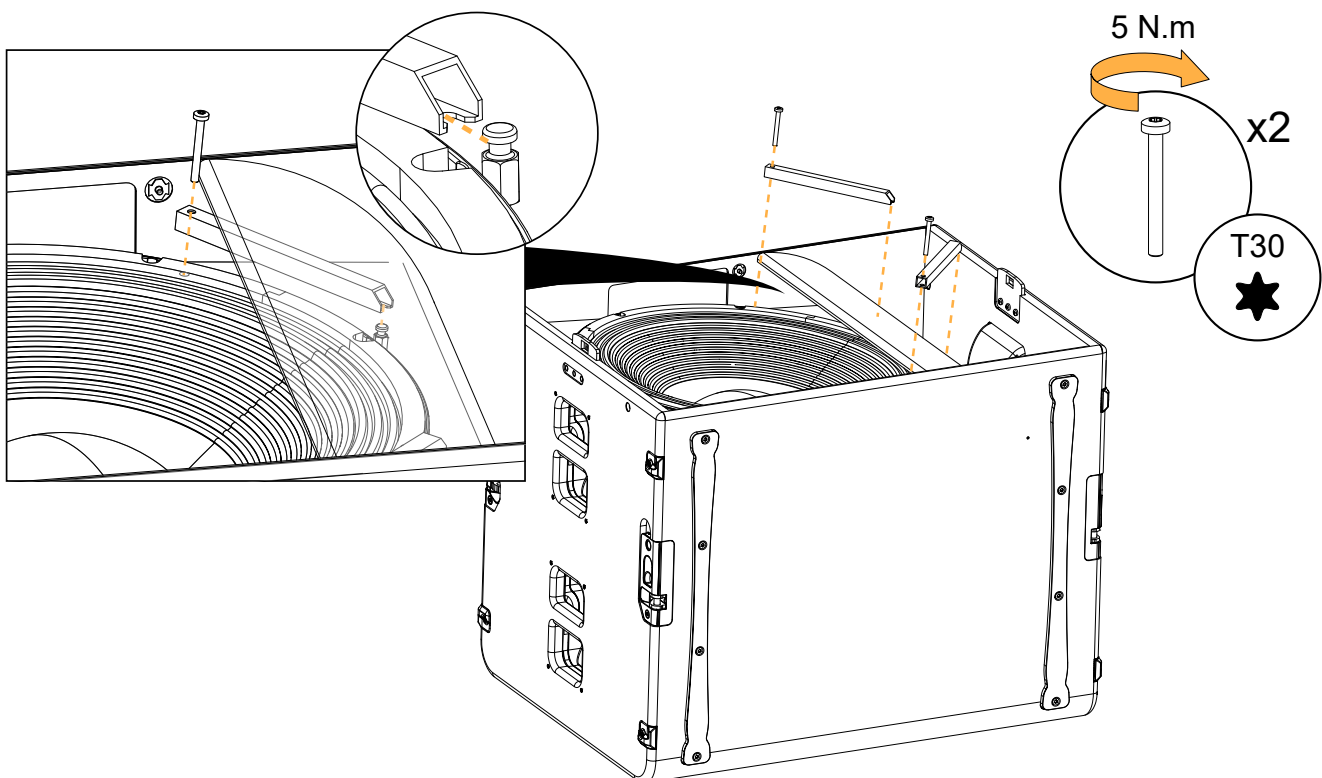

## D/R - LF speaker

### Tools

- torque screwdriver
- T30 Torx bit

### Repair kit

#### G03409

KR loudspeaker 21 KS21

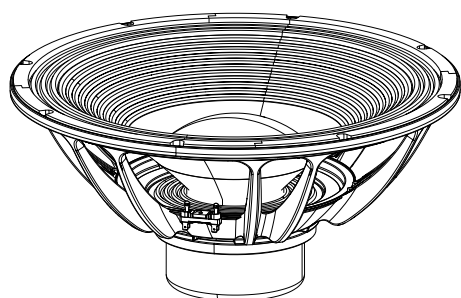

17945

21" LF speaker - 8 Ω

x1

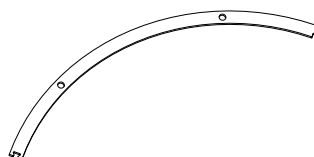

102157

21" speaker gasket

x4



S247

M6x35 Torx

x6

### Prerequisite

Grill removed.

See [Grill](#) (p.59).

### Exploded views



For safety reasons, always use the new screws and spare parts provided in the KR.  
If no new screws are available, use blue threadlocker.

Tilt the speaker to remove it from the cabinet. Carefully disconnect the cables.

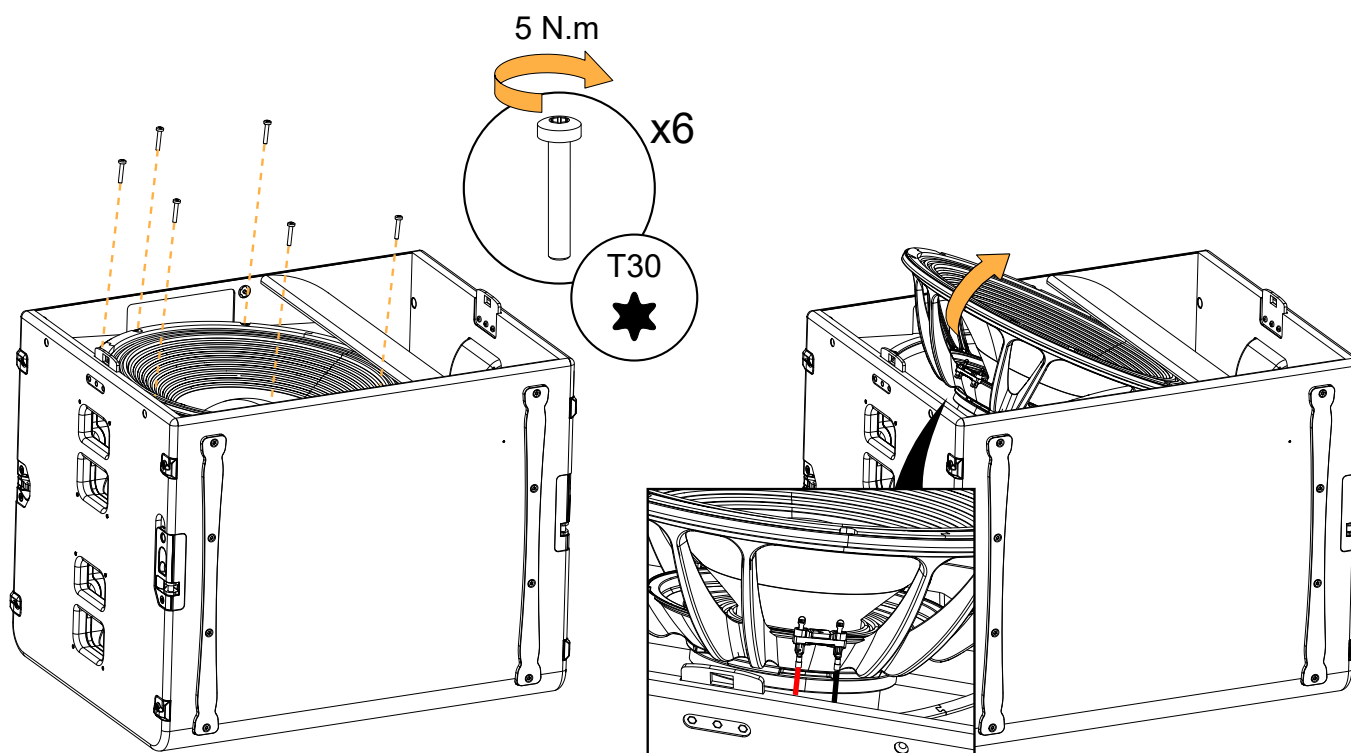



If the speaker gasket is damaged, remove and replace it.

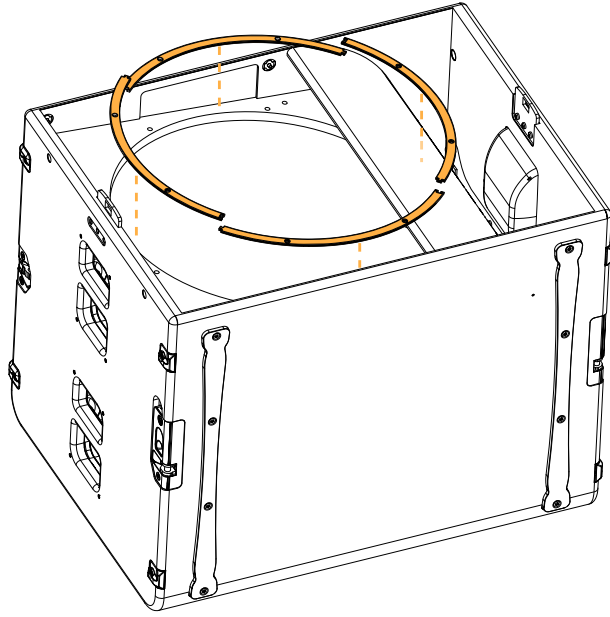

# Specifications

## KS21 specifications

---

<b>Description</b>	High power compact subwoofer: 1x21" , amplified by LA4X / LA8 / LA12X
<b>Low frequency limit (-10 dB)</b>	31 Hz ([KS21_100])
<b>Maximum SPL<sup>1</sup></b>	138 dB ([KS21_100])
<b>Nominal directivity</b>	standard or cardioid configuration
<b>Transducers</b>	1 × 21" neodymium cone driver
<b>Acoustical load</b>	bass-reflex, L-Vents
<b>Nominal impedance</b>	8 Ω
<b>Connectors</b>	IN: 1 × 4-point speakON LINK: 1 × 4-point speakON
<b>Rigging and handling</b>	flush-fitting 2-point rigging system 4 handles 8 corner stops 2 ground runners 1 pole mount with M20×150 insert
<b>Weight (net)</b>	49 kg / 108 lb
<b>Cabinet</b>	premium grade Baltic beech and birch plywood
<b>Front</b>	coated steel grill acoustically neutral 3D fabric
<b>Rigging components</b>	high grade steel with anti-corrosion coating
<b>Finish</b>	dark grey brown Pantone 426 C

<sup>1</sup> Peak level at 1 m under half space conditions using pink noise with crest factor 4 (preset specified in brackets).

## KS21 dimensions

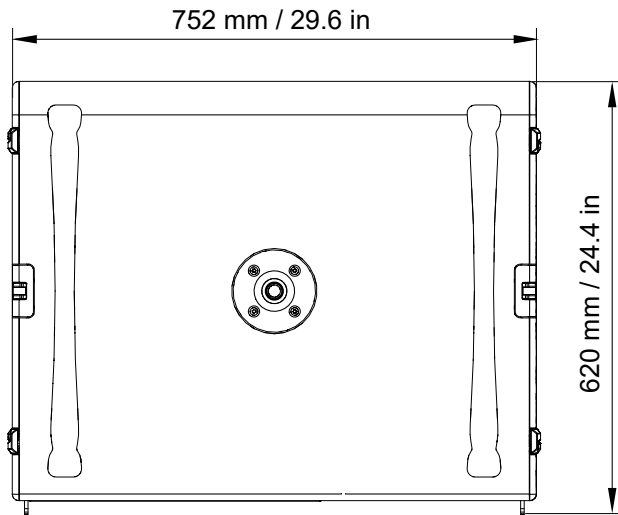
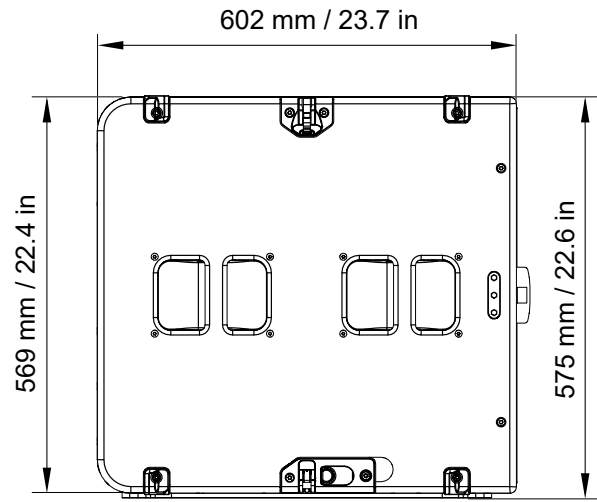
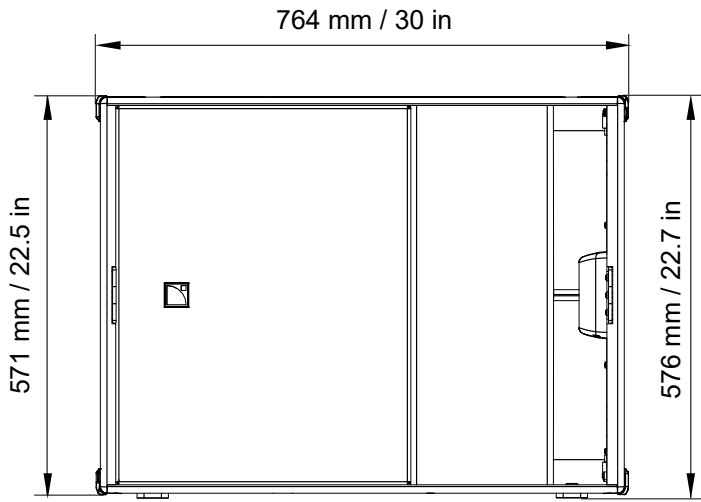

## A15-BUMP specifications

---

<b>Description</b>	Flying frame for vertical deployment of A15 and KS21 2 x Ø12 mm shackles WLL 1 t
<b>Weight (net)</b>	19 kg / 42 lb
<b>Material</b>	high grade steel with anti-corrosion coating

## A15-BUMP dimensions

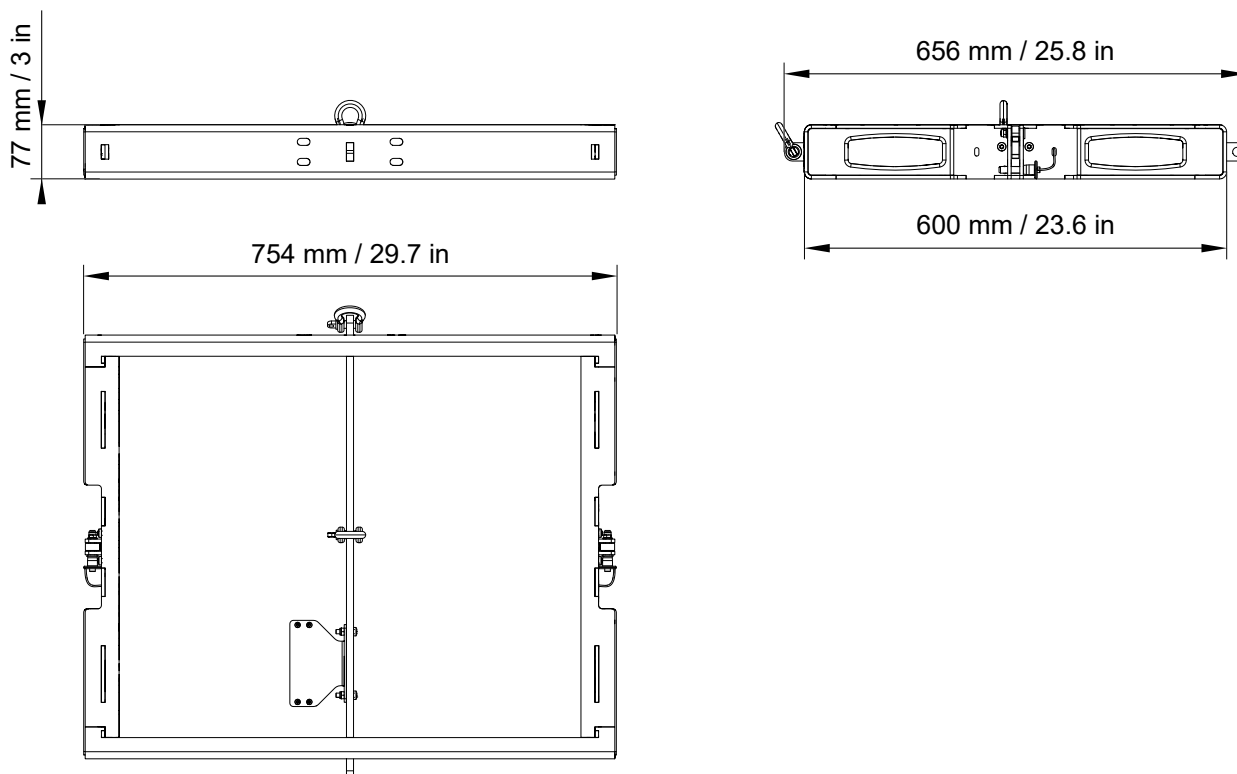

## A15-RIGBAR specifications

<b>Description</b>	Rigging bar and pullback for A15 and KS21 2 × Ø12 mm shackles WLL 1 t
<b>Weight (net)</b>	4.6 kg / 10 lb
<b>Material</b>	high grade steel with anti-corrosion coating

### A15-RIGBAR dimensions

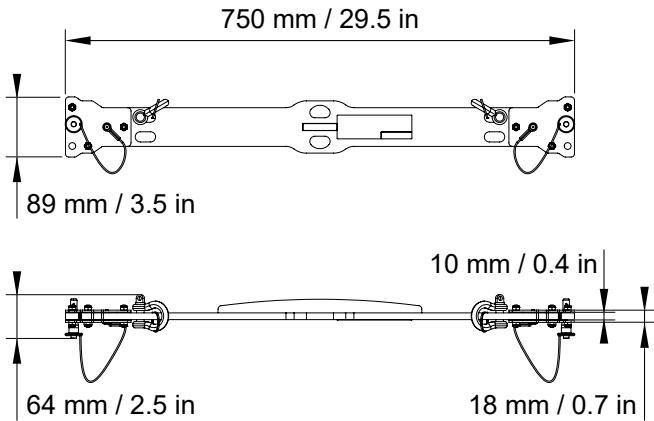

## KS21-OUTRIG specifications

**!** **Specifications for one KS21-OUTRIG bar.**  
Always use in pairs.

<b>Description</b>	Stability bars for KS21
<b>Weight (net)</b>	3.5 kg / 7.7 lb
<b>Rigging and handling</b>	2 ground runners
<b>Material</b>	high grade steel with anti-corrosion coating, high density polyethylene (runners)

### KS21-OUTRIG dimensions

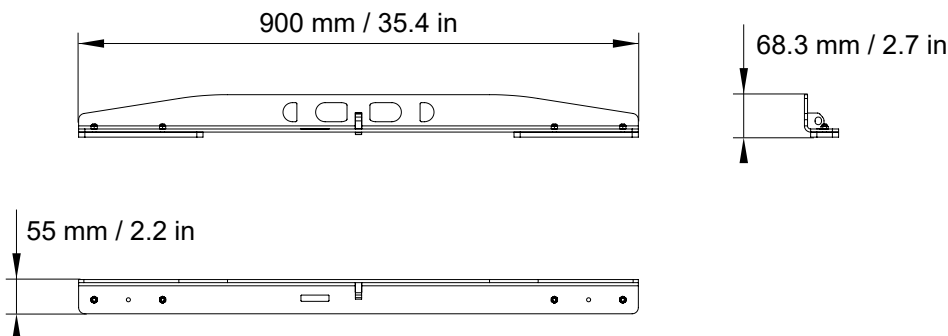

## KS21-CHARIOT specifications

---

**Description** Chariot for up to 3 KS21

**Weight (net)** 23.6 kg / 52 lb

### KS21-CHARIOT dimensions

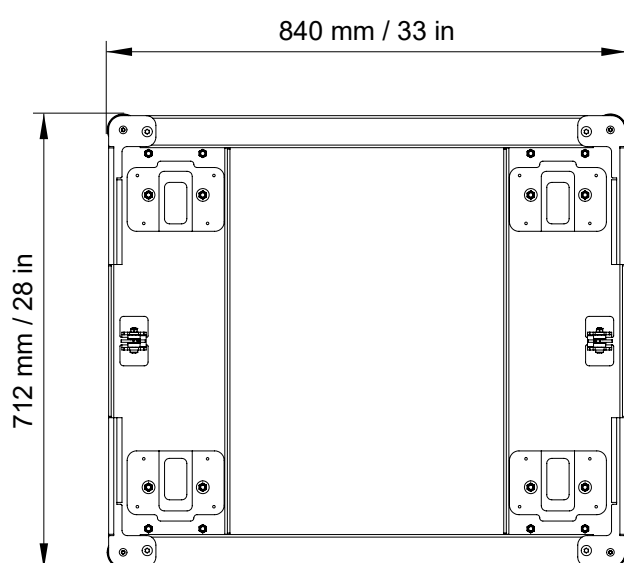
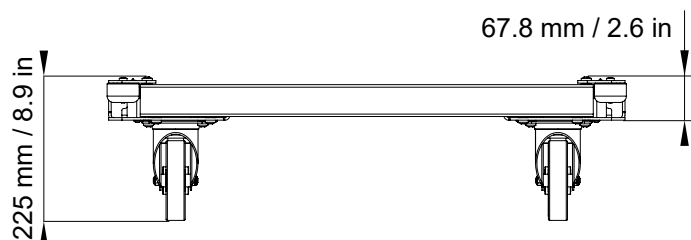

## K2-JACK specifications

---

<b>Description</b>	4 tilt adjustment screw jacks + bar for K2-CHARIOT
<b>Weight (net)</b>	10.1 kg / 22.3 lb (for one stabilizer)
<b>Material</b>	high grade steel with anti-corrosion coating

### K2-JACK dimensions

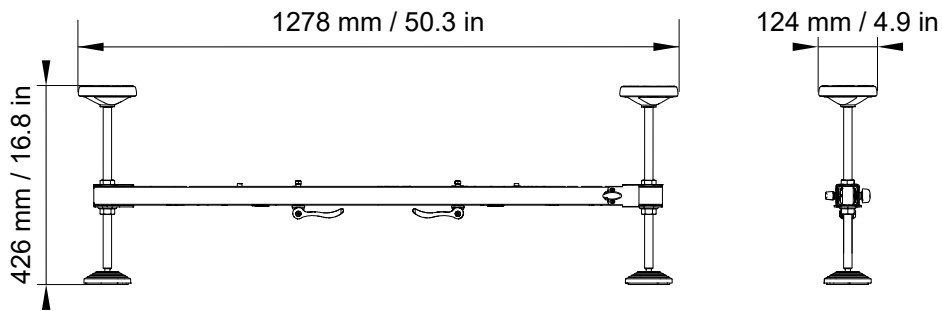

## CLAMP250 specifications

---

<b>Description</b>	Clamp certified for 250 kg
<b>Weight (net)</b>	1.8 kg / 4 lb
<b>Material</b>	high grade steel with anti-corrosion coating

## CLAMP250 dimensions

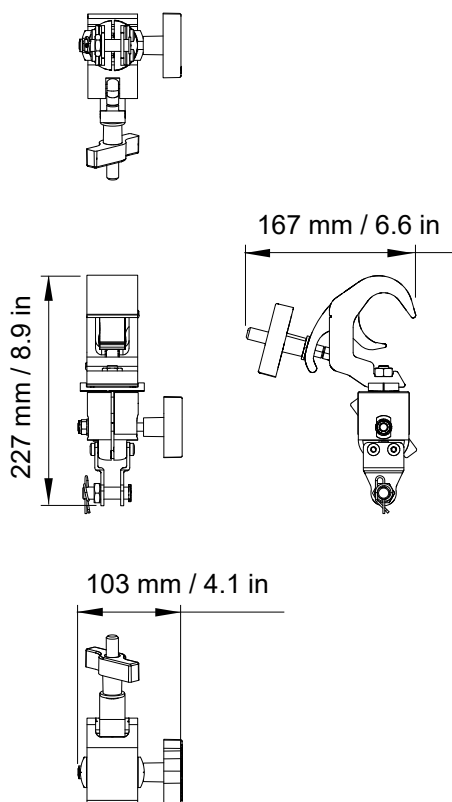

## KS21-PLA specifications

---

**Description** Removable front dolly for 1 KS21

**Weight (net)** 9.5 kg / 21 lb

### KS21-PLA dimensions

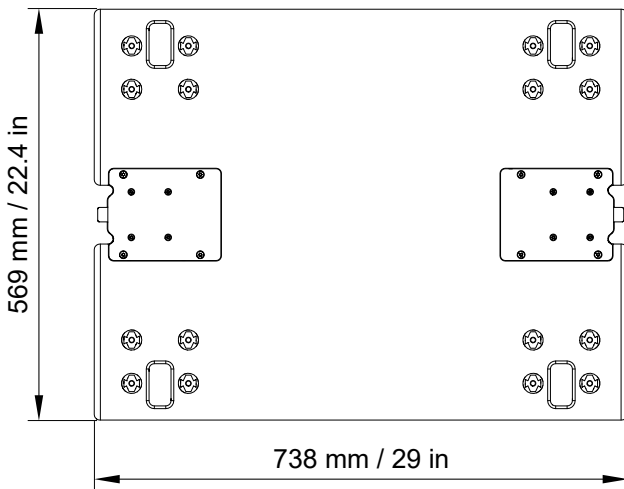
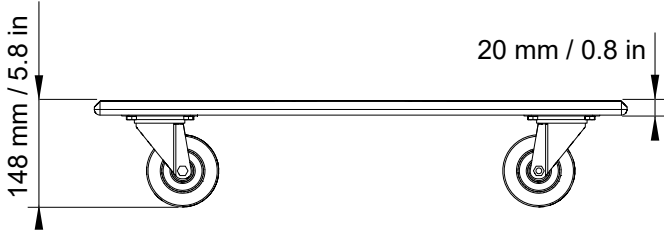

## Recommendation for speaker cables

Follow the recommended maximum length for loudspeaker cables to ensure minimal SPL attenuation.



### Cable quality and resistance

Only use high-quality fully insulated speaker cables made of stranded copper wire.

Use cables with a gauge offering low resistance per unit length and keep the cables as short as possible.

The table below provides the recommended maximum length for loudspeaker cables depending on the cable gauge and on the impedance load connected to the amplifier.

cable gauge			recommended maximum length					
			8 Ω load		4 Ω load		2.7 Ω load	
mm <sup>2</sup>	SWG	AWG	m	ft	m	ft	m	ft
2.5	15	13	30	100	15	50	10	33
4	13	11	50	160	25	80	17	53
6	11	9	74	240	37	120	25	80

Use the more detailed L-Acoustics calculation tool to evaluate cable length and gauge based on the type and number of enclosures connected. The calculation tool is available on our website:

<https://www.l-acoustics.com/en/installation/tools/>



**L-Acoustics**

13 rue Levacher Cintrat - 91460 Marcoussis - France  
+33 1 69 63 69 63 - [info@l-acoustics.com](mailto:info@l-acoustics.com)  
[www.l-acoustics.com](http://www.l-acoustics.com)



 **L-ACOUSTICS**  
GROUP