



WLAN OTA MEASUREMENT SOLUTION

COVERED PRODUCTS

- » RTS, Reverberation Test System
- » TRU3 WLAN Throughput Reference Unit
- » ISS11 Attenuator System
- » TTS3 WLAN Throughput Test System
- » Bluetest Flow software platform

SOLUTION OVERVIEW

This application note describes Bluetest's complete WLAN Over-the-Air (OTA) test solution consisting of the TRU3 WLAN throughput reference radio, ISS11 Attenuator System, TTS3 WLAN throughput test system, and any of Bluetest's reverberation chambers from the RTS-family. Focus is on the use with the WLAN/Bluetooth dedicated RTS25 reverberation chamber, but the solution is applicable also to the larger reverberation chambers RTS65, RTS85, RTS95 and RTS105.

RTS25 REVERBERATION TEST SYSTEM

The RTS25 has been introduced to address the increasing need for efficient test systems targeting WLAN and Bluetooth measurements. It supports the 2.4 GHz and 5 GHz ISM-bands as well as the recently added 6-7.125 GHz band, hence covering all existing WLAN and Bluetooth applications. Up to 8 measurement antennas provide flexibility to the system and an expansion possibility to 8x8 MIMO if needed. The chamber is, with its outer dimensions of 0.8m x 1.5m x 1.4m, quite compact and fits through most doorways. Bluetest Flow measurement and control software resides on the included RTSc controller unit where measurements can easily be initiated and supervised through the touch screen.

Further information can be found in the RTS25 data sheet [1].

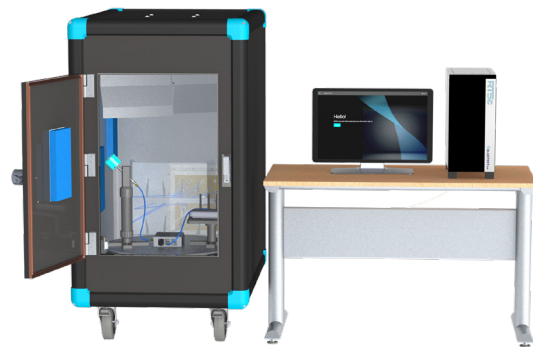

1. RTS25 Reverberation Test System including RTSc controller unit with touch screen

TRU3

The TRU3 is a triple-band WLAN reference radio that can be set to both access point mode and WLAN client (station) mode. It enables data throughput measurements vs received power level in both uplink and downlink direction. The WLAN radio supports 802.11be in all bands (Wi-Fi 6 & 6e) as well as the legacy standards 802.11a/b/g/n/ac/ax.

Settings include parameters such as WLAN standard, bandwidth, region, SSID, channel number and adaptive or fixed MCS.



2. TRU3 WLAN Reference Radio with 4x4 MIMO

The output power is calibrated, making it possible to conduct throughput measurements vs received power (rather than vs path loss), as well as comparing results between Bluetest test systems in different locations.

ISS11 ATTENUATOR SYSTEM

The ISS11 Attenuator System is used to control the path loss between the TRU3 WLAN reference radio and the Device Under Test (DUT) located inside the reverberation chamber. It contains four remotely controlled step attenuators with up to 90 dB dynamic range in 1 dB steps. Further information can be found in the ISS11 Attenuator System data sheet [2].



3. ISS11 Attenuator System

FLOW MEASUREMENT SOFTWARE

Flow is Bluetest's software platform that is used to configure, control, supervise and analyze measurements in the RTS. It consists of three main parts as shown below in Flow Platform Overview. Flow enables very advanced measurements, while at the same time allowing you to become productive with a very short introduction to the system. Flow is integrated in all Bluetest's hardware products and makes your system a complete, easy-to-use, and powerful test solution.

FLOW PLATFORM OVERVIEW

FLOW TOUCH

Flow Touch is a touch interface that can be used on any device with a web browser. Flow Touch allows you to control and monitor your measurements remotely. Start, stop and pause the measurements are just a few examples of the possibilities. Flow touch comes with the touch screen included in your RTS chamber or RTSc.



FLOW MANAGER

Flow Manager is the desktop client in which you configure your measurements. You set up your measurements, create batches and add multi parameter sweeps. Define your measurements as you want whether you are a new or advanced user. You are guided in Flow Manager by the built-in user manual, to make your life easier.



FLOW ANALYZER

Flow Analyzer is the result and data processing tool that gives you endless opportunities to plot your data as you want. Search for your results in the built-in database and compare your measurements. Create your own design for plots and graphs, put them in a report format and export your results.

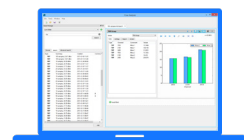

TTS3 THROUGHPUT TEST SYSTEM

The TTS3 Throughput Test System combines the functionality of the TRU3 with built-in attenuators to allow for per-band control of the path loss between the radio and the DUT. This enables the user to control and test more complex scenarios. For example, the power to all three frequency bands can be balanced during MLO measurements.



4. TTS3 Throughput Test System

MEASURING A WLAN CLIENT

UDP or TCP IP traffic is generated by Flow server. The traffic is sent through the TRU3/TTS3 WLAN reference radio to the DUT OTA. The Bluetest IP Throughput Application is installed on the device and reports back the received IP traffic. The app is available for most operating systems such as Android, iOS and Linux. The TRU3/TTS3 is acting as the access point to which the client (DUT) is connected. The path loss is controlled by the TTS3 or with an ISS11 Attenuator System, enabling the throughput performance to be measured vs received power.

The TRU3/TTS3 also supports data throughput measurements without the app loaded on the client. This is similar to a throughput measurement on the MAC layer and can be useful for clients where it may be difficult to load external applications such as many

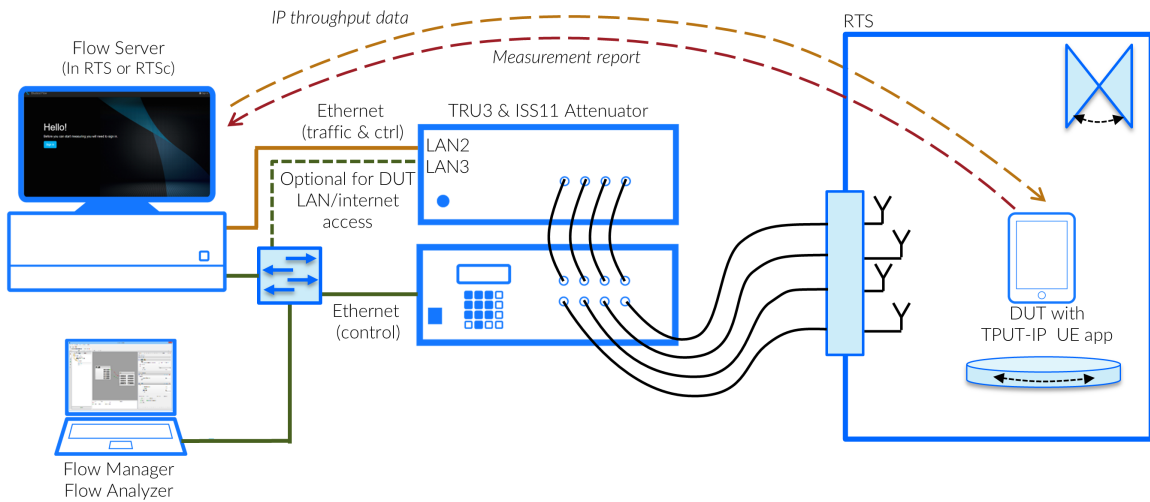

5. System configuration for device tests with TRU3 and ISS11

IoT devices. We call these “app-less” throughput measurements.

MEASURING AN ACCESS POINT

The measurement of access point performance is quite similar to the client measurement but the TRU3/TTS3 is now acting as the WLAN client. The IP Throughput app can now either be loaded directly on the access point, if possible, or on an external device connected through Ethernet to the access point.

MEASUREMENT EXAMPLE

Figure 7 shows a TCP/IP throughput vs path loss measurement example for a mobile phone with 802.11ax, 2x2 MIMO in the three different bands (6 GHz, 5 GHz and 2.4 GHz band) and with 3 different bandwidths (160 MHz, 80 MHz and 40 MHz respectively).

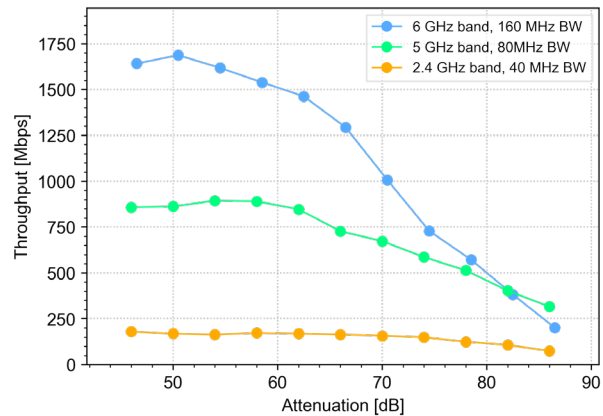

7. Throughput vs. power WLAN measurement results on 3 channels and 3 bandwidths

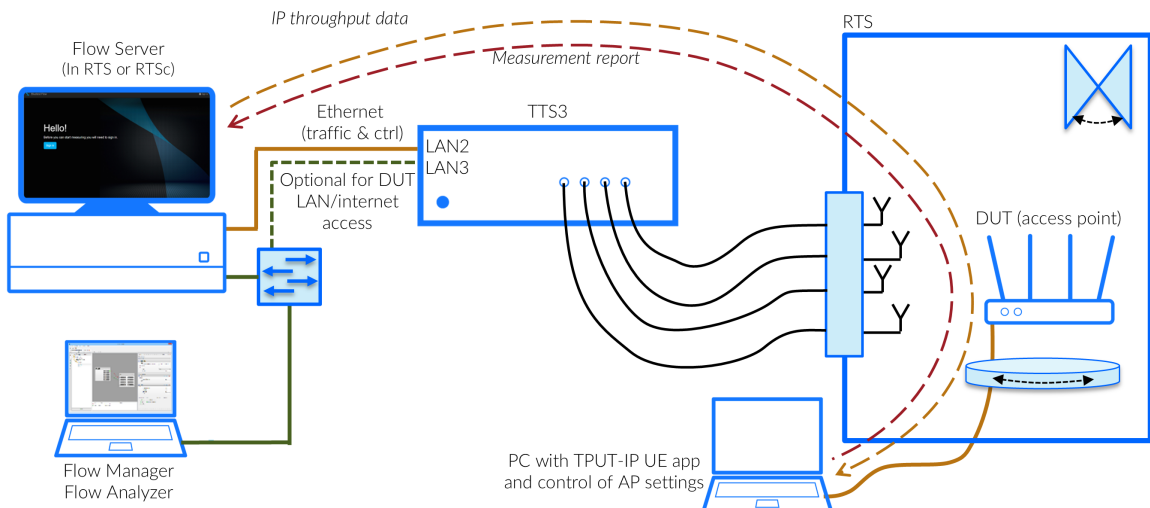

6. System configuration for access point tests with TTS3

TRU3 & ISS11 Attenuator System includes

- 1 pc TRU3 with external DC power supply and a GbE jumper cable
- 1 pc ISS11 Attenuator System with power cord
- 4 pcs N-N TRU3 to ISS11 Attenuator System coaxial interconnect cables

TTS3 System

- No additional hardware required

For ordering information, please contact your Bluetest representative.

SOLUTION SPECIFICATION

Supported WLAN standards	802.11a/b/g/n/ac/ax/be
Frequency coverage	2.4 GHz: 2.412~2.472 GHz 5 GHz: 5.150~5.825 GHz 6 GHz: 5.925 - 7.125 GHz
Bandwidths	20 to 320 MHz (depending on band and standard)
MIMO	Up to 4x4 MIMO and MU-MIMO
Modulation	Up to 1024 QAM (depending on standard)
Dynamic range	Up to 90 dB
Attenuation resolution (nominal)	1 dB
Flow traffic generator capacity	Up to 10 Gbps
Chipset	Qualcomm based
RF connectors	N-female

For RTS25 specific data, see [1].

REFERENCES

[1] RTS25 Data Sheet, BTD-16-085

[2] ISS11 Attenuator System Data Sheet, BTD-14-044

ABOUT BLUETEST

Bluetest is the world leader in over-the-air measurements of wireless devices. We provide reverberation chambers that are developed to help our engineering customers to optimize antenna performance and to accurately measure radio transmitters and receivers in devices, in a real world environment.

Thanks to our products, consumers can enjoy a better wireless experience and the industry benefit from more efficient wireless systems.

The content in this application note is subject to change without notification.



<https://bluetest.se>

CONTACT US

 <https://bluetest.se>

 sales@bluetest.se

 +46 31 7786161

 **Bluetest AB**
Lindholmsallén 10
417 55 Gothenburg
Sweden

BAN-25-001 Rev.A