

## MEET THE HEAT SEAL HDX4000

This next-generation box-motion side seal shrink packaging machine delivers unmatched speed, precision, and reliability. Engineered for efficiency, it reduces waste, maximizes throughput, and ensures flawless results. Durable, easy to operate, and cost-effective, it's the smartest investment for businesses seeking advanced, dependable automatic shrink packaging.



### KEY FEATURES & BENEFITS

# HDX 4000

## CONTINUOUS MOTION

#### High-Speed Continuous Motion Seal Bar

Achieve production speeds of up to 120 parts per minute thanks to a seal bar that operates without halting the conveyor, keeping your line moving and your output high.

#### All-Electric Efficiency

Operate with zero pneumatic connections, reducing both maintenance needs and utility costs for a cleaner, more cost-effective solution.

#### Precision with Six Brushless Servomotors

Enjoy exceptional accuracy and control while cutting energy use. These high-efficiency motors optimize performance and lower operating expenses.

#### Full-Access Design with Gullwing Doors & LED Lighting

Four gullwing-style doors and bright center-mounted LED lights provide unmatched visibility and access making maintenance, film threading, and service faster and easier.

#### Flexible Operation with Swing-Arm Controls

PLC controls mounted on a versatile swing arm allow intuitive operation from either side of the machine, supporting a wide range of production layouts.

#### Advanced Touchscreen PLC Control

A bright 7-inch full-color touchscreen interface centralizes control of the entire system. Store up to 250 custom packaging recipes, control conveyors and GT tunnel, and streamline your workflow.

#### Automatic Seal Centering

Delivers perfectly aligned seals every time, ensuring a clean, professional finish that enhances product presentation.

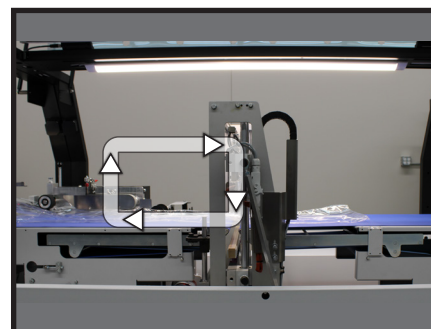

Continuous Box Motion Seal Bar



4 Gullwing Doors

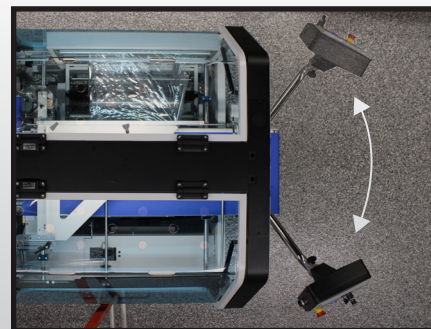

PLC On Swing Arm

Model Specs	Details
Model Number	HDX 4000
Overall Machine Dimensions	145 in x 54in x 62 in
Parts/Min	Up to 120 p/m
Min/Max Product Dimensions (Width)	15.75 in
Min/Max Product Dimensions (Height)	9.44 in
Min/Max Product Dimensions (Length)	∞
Other Features	Limited 2 year parts only

# APPLICATIONS

### Pharmaceutical & Nutraceutical Packaging

Ideal for multi-pack pill sorting, blister packs, and wellness supplements.

### Document & Print Fulfillment

Efficient handling of bulk letter stock, catalogs, and direct-mail campaigns.

### Pet Product Assembly

Streamlined kitting for toys, treats, and accessory packs.

### Beverage Multipacks

Secure and consistent packaging for beer, seltzers, and specialty drinks.



Center LED Lights

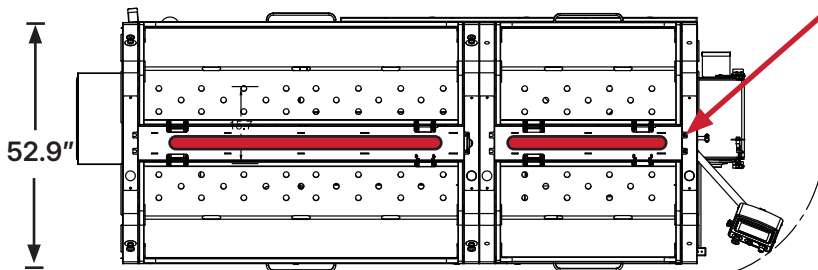

Touchscreen PLC

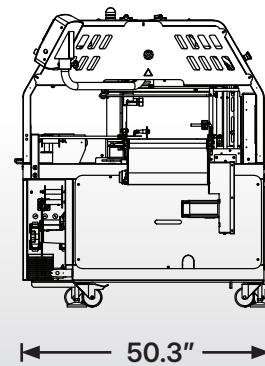
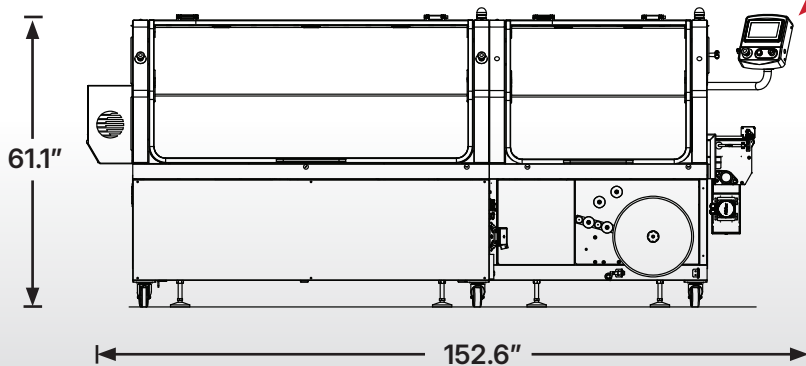

## CONTACT INFO

Phone: (216) 341-2022

Email: [user@heatsealco.com](mailto:user@heatsealco.com)

Web: [www.heatsealco.com](http://www.heatsealco.com)

4922 East 49th Street, Suite 100 | Cleveland, OH 44125 USA