

First Responders Interaction Plan

# Tensor Gen5 Driverless Vehicle

Version 2.0

Effective June 7, 2026



This document describes the procedures for law enforcement officers and first responders to safely interact with Tensor Gen5 driverless vehicle(s) based on the Chrysler Pacifica Hybrid, and supplemental information related to the Tensor autonomous driving technology.

This guide is intended to be used by trained first responders and assumes a professional-level background in safely responding to emergencies, including those involving damaged vehicles.

This plan is reviewed at least annually and upon any material change to the vehicle, ODD, or these procedures.  
Last reviewed: June 5, 2026.

# Own Your Autonomy

Our vision is a future where individuals own their own Artificial General Intelligence — a personal AGI that empowers you with more time, more freedom, and greater autonomy.

# Table of Contents



## 1. Introduction

1.1	Identifying the Tensor Gen5 Driverless Vehicle	6
1.2	Operational Design Domain of Tensor Driverless Vehicles	8
1.3	Location of Vehicle Identification Documents	10

## 2. Communicating with the Tensor Team

2.1	Tensor Driverless Vehicles First Responder Line	12
2.2	Tensor Operation Support Team	13

## 3. Interacting with the Vehicle under Incidents & Emergency Scenarios

3.1	Response to Police and Emergency Vehicles	15
3.2	Post-Collision Response	16
3.3	Approaching the Vehicle	17
3.4	Ensuring the Vehicle is Immobilized	18
3.5	Disengaging a Tensor Vehicle from Autonomous Mode	19
3.6	Determine and Verify that the Vehicle is in Parking Mode	20
3.7	Turning the Engine Off	21
3.8	Opening the Trunk	22
3.9	Towing a Tensor Vehicle	23

# Table of Contents



## **4. Base Vehicle Safety Emergency Response Guide**

4.1	Procedure to Disable 12 V and High Voltage (HV) Power	25
4.2	Disconnecting the Base Vehicle 12 V Low Voltage Battery	26
4.3	Disconnecting Base Vehicle 12 V without Hood Access	27
4.4	Disconnecting the Additional 12 V Battery	28
4.5	Disabling High Voltage Output from the HV Battery	29
4.6	Extrication Considerations	30
4.7	Recommended Cut Points for Extrication	31
4.8	Extrication Considerations for High Power Electrical Systems	32
4.9	Extrication Considerations for Fuel and other Fluid Systems	33
4.10	Extrication Considerations for Restraint Systems	34
4.11	Extrication Considerations for Tensor Autonomous Driving System Considerations	35
4.12	Extrication Considerations for the Tensor Autonomous Driving Cooling System	36
4.13	In Case of Fire	37
4.14	Post-incident Handling	38

1

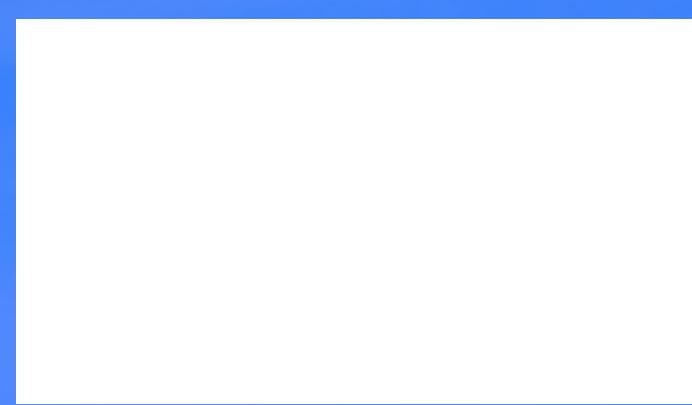

# Introduction

 TENSOR

 TENSOR



# Identifying the Tensor Gen5 Driverless Vehicles

The Tensor Gen5 Driverless vehicle fleet in California are based on the Chrysler Pacifica Hybrid minivans. You can easily identify the Tensor Gen5 vehicles by the signature twin sensor towers on top of the vehicle, the Tensor logos on each side of the vehicle, and blindspot sensor additions on each side of the vehicle.



# Identifying the Tensor Gen5 Driverless Vehicles



Each Tensor Vehicle is equipped with license plate and Tensor logo or word mark. Tensor driverless vehicles are fully autonomous at all times during autonomous testing and operation, and will not have any driver in the driver seat controlling these vehicles.

# Operational Design Domain of Tensor Driverless Vehicles

## Level of Automation

The Tensor Gen5 vehicles meet the description of a Level 4 automated driving system under SAE International's *Taxonomy and Definitions for Terms Related to Driving Automation Systems for On-Road Motor Vehicles*, standard [J3016](#). Tensor driverless vehicle is designed to perform the entire dynamic driving task within a defined operational design domain and has the capability to achieve a minimal risk condition without any expectation that a human driver will intervene.

## Where Will the Tensor Driverless Vehicles Be Seen?

Tensor driverless vehicles will be seen in a clearly defined area in [San Jose, CA](#). This area contains some area of [zip code 95131, 95134, 95054](#).

- As we gather more experiences, we will continue to unlock new geographical areas, weather and other operational conditions via rigorous testing and validation. We will work closely with the DMV and authorities as such initial ODD constraints are updated.
- Information relating to these areas is provided by Tensor directly to state and local authorities, prior to any driverless operation.

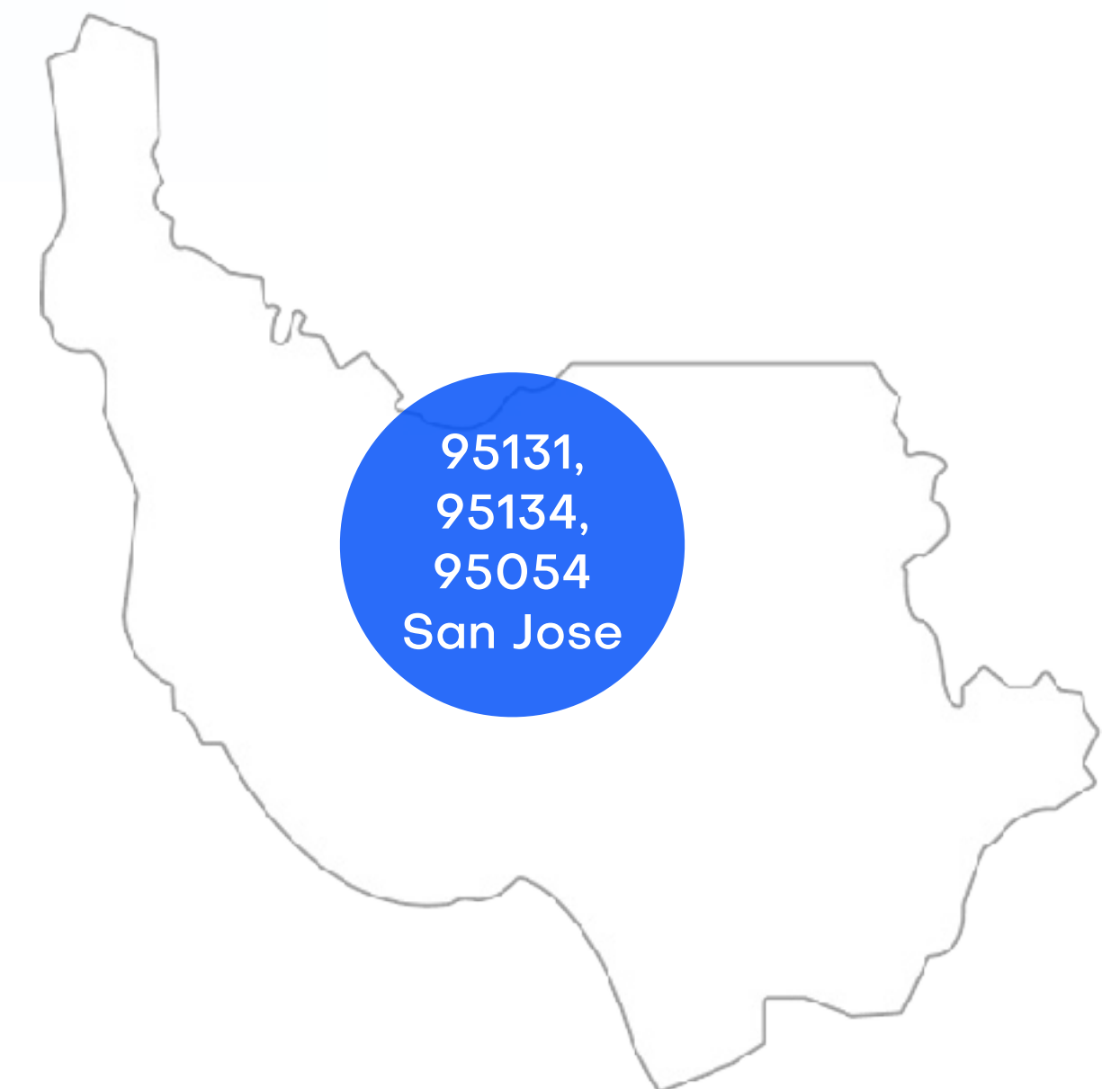

# Operational Design Domain of Tensor Driverless Vehicles

## Weather Conditions

Weather conditions will be evaluated based on the 7-day forecast by the National Weather Service. If weather conditions change during a test, and no longer adhere to the operational design domain, Tensor will pause or cancel the planned test until the ODD conditions are met. The driverless vehicle will pull over and come to a safe stop, either by the autonomous driving system or under the instruction of the assistance team. Specifically, Tensor will only conduct driverless vehicle tests under the following mild and clear local weather conditions:

- ☒ Visibility: greater than 4.50 miles, at all times including day and night;
- ☒ Wind Speed: less than 20 MPH;
- ☒ Precipitation: light rain with less than 1 inch (daily rate of rainfall), light fog.

## Roadway Type

- ☒ On public roads (defined by Vehicle Code section 360), streets (defined by Vehicle Code section 590), with posted speed limits up to 45 mph.
- ☒ In off street public parking facilities (defined by Vehicle Code section 4000).

## Other Requirements

- ☒ Tensor testing vehicles are capable of adhering to posted speed limits and will not exceed 50 mph.

# Location of Vehicle Identification Documents

There are two physical copies of the vehicle owner information, vehicle registration, and proof of insurance in every vehicle.

- A. 1 copy is attached to the sun visor in front of the driver seat;
- B. 1 copy is attached to the sun visor in front of the front co-driver seat.



2

# Communicating with the Tensor Team

# Tensor Driverless Vehicle First Responder Line

**Not Urgent**



[safety@tensor.ai](mailto:safety@tensor.ai)

**Urgent Contact**

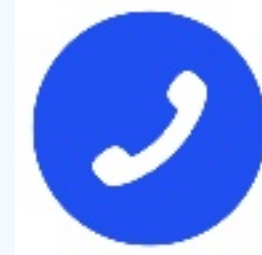

**408-476-6320**

**Main Address**



**441 W Trimble Rd,  
San Jose, CA 95131**

The urgent contact phone number (408-476-6320) is dedicated to allowing police, fire departments, and other **first responders** to communicate directly with Tensor's response team. This line is answered by a trained remote operator **within 30 seconds**, at all times during our driverless vehicles are on a public road.

If you have additional non-urgent questions regarding the Tensor Gen5 vehicle, please contact [safety@tensor.ai](mailto:safety@tensor.ai)

# Tensor Operation Support Team

## Operation Support Center

The remote operator maintains situational awareness of all Tensor vehicles and can immobilize the vehicle, permit a responder to move it, or move it as directed. Available all hours when a Tensor driverless vehicle is operating on public road.

### Customer Service

- Support customer inquiries
- Escalates to Remote Assistance team

### Remote Assistance

- Remotely interacts with First Responders through 2-way audio communication
- Remotely supports the vehicle with enhanced functions
- Escalates to Roadside Assistance team

### Roadside Assistance

- Responds on-site to a scene
- Directly interacts with First Responders
- Move the vehicle if needed

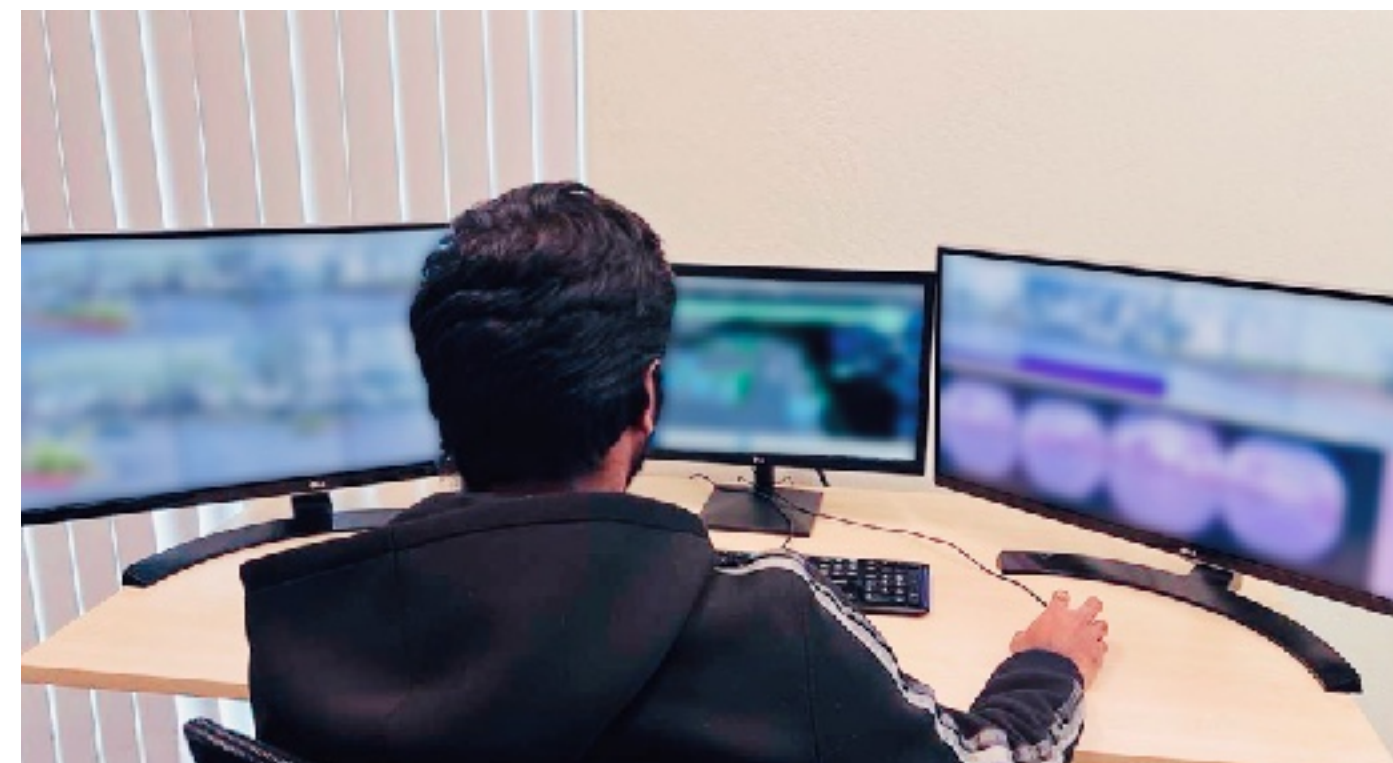
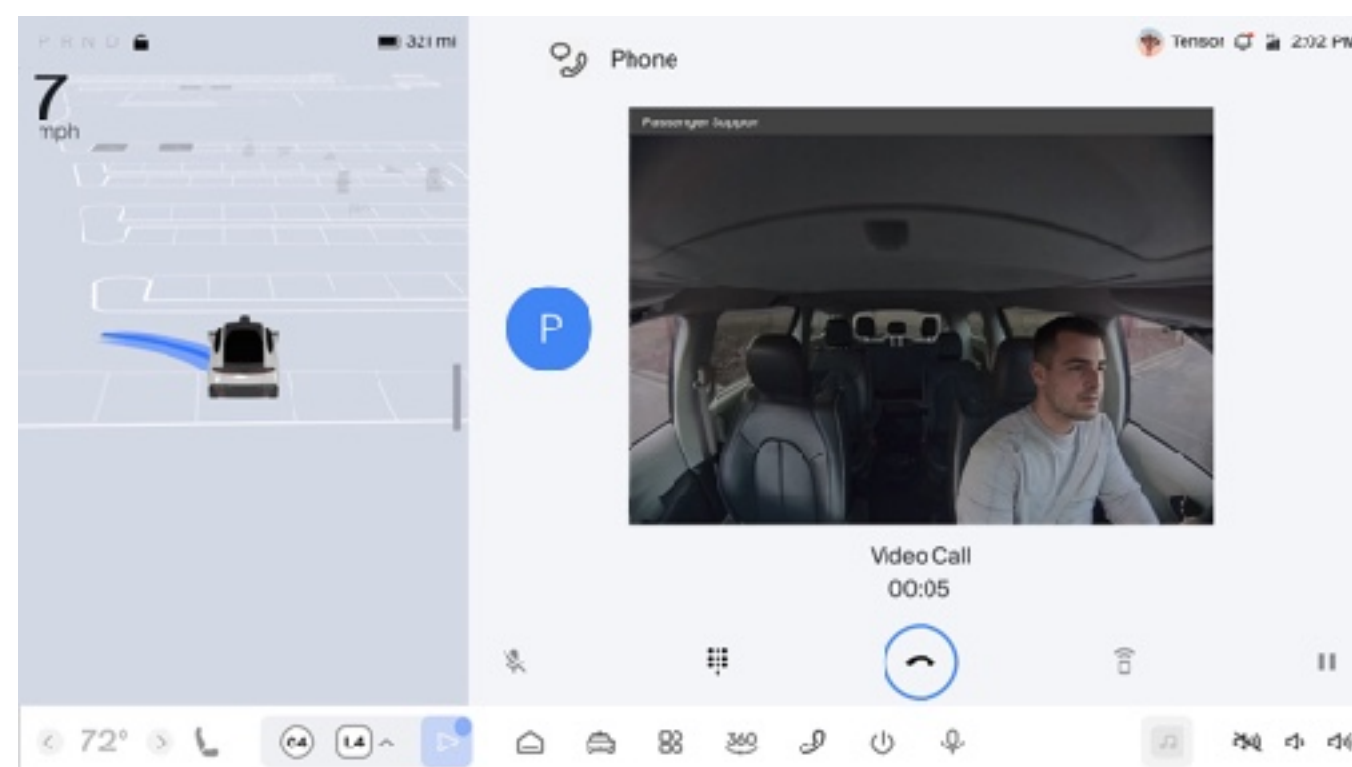

3

# Interacting with the Tensor Gen5 Vehicle under Incidents & Emergency Scenarios

# Response to Police and Emergency Vehicles

The Tensor driverless vehicles are capable of detecting and recognizing police or emergency vehicles. If a Tensor driverless vehicle detects that a police or emergency vehicle is approaching with a siren on from any direction, the Tensor driverless vehicle is designed to be able to behave appropriately according to the situation. It will also notify the remote assistance team for immediate assistance if necessary. For example, if an emergency vehicle is approaching from behind, the Tensor Vehicle will pull over when it finds a safe place to temporarily park.

During Tensor driverless vehicle tests, roadside assistance team will be ready to provide immediate on-site support to first responders and other road users when such support is needed.

# Post-Collision Response

- A. The Tensor driverless vehicles are capable of detecting that it was involved in a collision. In addition, the Tensor response team could also verify whether the driverless vehicle is involved in a collision.
- B. If a collision occurs or is imminent, the Minimal Risks Maneuvering (MRM) process will be triggered. The MRM process will lead the driverless vehicle to a full stop and immediately notify the response team.
- C. The Tensor roadside assistance team nearby will make an initial assessment of any out of the ordinary circumstances, and call 911 if there is an accident involving other road users or damage to public properties.
- D. The Tensor roadside assistance team nearby will be immediately dispatched to provide on-scene support, provide assistance to law enforcement officers and first responders in operating or interacting with the driverless vehicle.
- E. Depending on the situation, the driverless vehicle may pull over by the side of the road, or stop at the next nearest safe parking location. In the event an airbag is deployed, the base vehicle's engine and hybrid drive will be disabled.

# Approaching the Vehicle

## Approach from driver side of the vehicle.

- When the Tensor vehicle comes to a stop, it will keep its hazard lights on, unlock all four doors, and remain in Park gear.

## Identify the vehicle's autonomous mode

- A screen from the driver side window will confirm the autonomous mode when no safety driver is present. If a safety driver is present, the first responder can communicate with the driver directly.

## Identify passenger presence

- Look through the vehicle side windows. Passengers are only allowed in the 2nd, or 3rd row. Only company employees may sit on the first row.



A red 'MANUAL' screen confirms autonomous mode is deactivated; green 'AUTO'/purple 'DRIVERLESS' means it is still active.

# Ensuring the Vehicle is Immobilized

Do any one of the following to ensure the vehicle is immobilized (to ensure the vehicle will not drive autonomously):

## 1. Any Car Door is Open



### REMINDER

Call Tensor Emergency Line (408-476-6320) to unlock the doors if the situation allows. If immediate entry to the vehicle is necessary, break a door window to open the doors.

## 2. Vehicle in Park



## 3. Parking Brake is Applied



### RECOMMENDED

Keep at least one door open to ensure the vehicle is immobilized!

# Disengaging a Tensor Driverless Vehicle from Autonomous Mode

Emergency responders needing to disable autonomous mode should contact Tensor using one of the following methods:

📞 Call and speak with a Tensor response team member at: 408-476-6320.

📞 There is an on-board two-way radio (walkie-talkie) located under the middle cup holder between the driver's seat and the front passenger seat.

📞 Interact with the operation support team through in-vehicle call.

- If the vehicle is occupied by any passengers, the passenger will have to confirm the call from the console. To communicate with the remote assistance, simply ask the passenger to lower the window.
- If there is no passenger in the vehicle, the in-vehicle call will be established automatically by the customer service. To communicate with the remote assistance, simply open the rear door of the vehicle.

 Urgent Contact **408-476-6320**

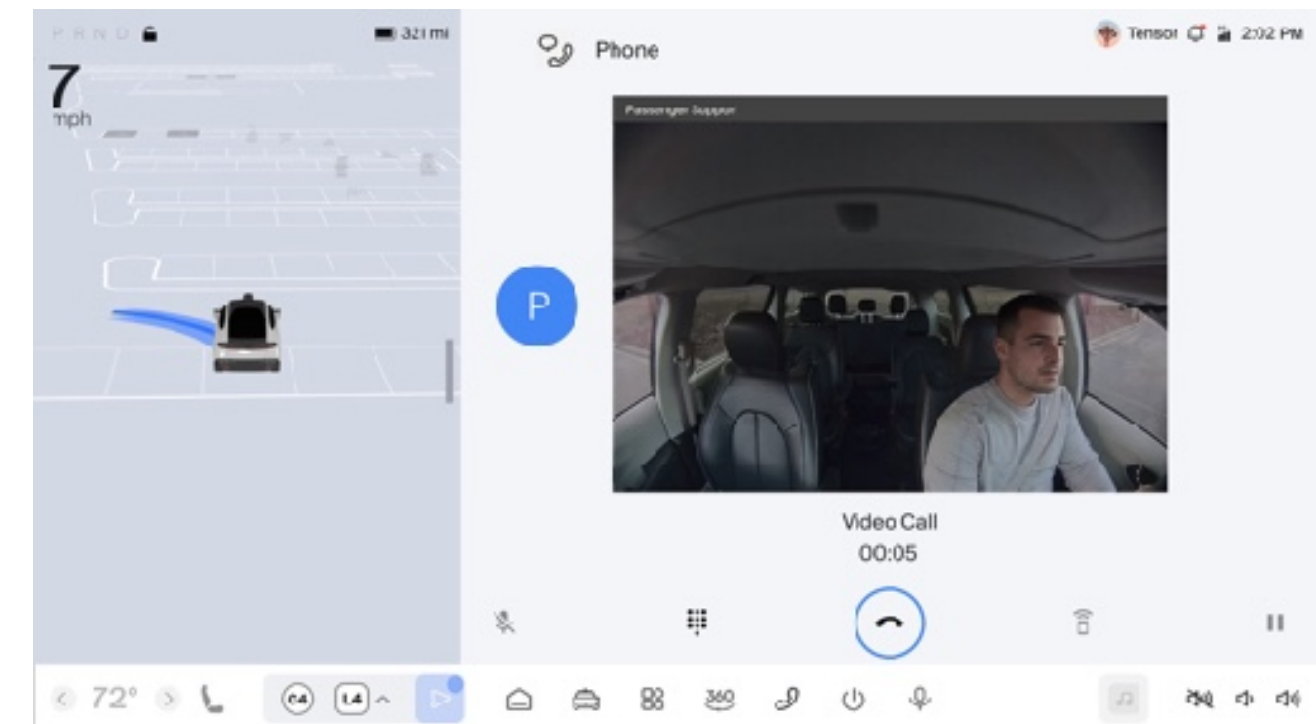

- 📞 Identify yourself and the vehicle, provide location information.
- 📞 Follow the step-by-step instruction from the Tensor response team on how to safely interact with the Tensor vehicle.

# Determine and Verify that the Vehicle is in Parking Mode

## 1 Electronic Shift Control

Blue “P” (Park) indicator on the Electronic Shift Control shows whether the vehicle is in Park.



## 2 Parking Brake

Red light indicates the Parking Brake is applied.

Vehicle in Park + parking-brake light on + MANUAL screen = autonomous mode confirmed off and vehicle immobilized.

### ! REMINDER

In Driverless mode, refer to Page 19 to disengage a Tensor Driverless Vehicle.

### ! RECOMMENDED

Keep at least one door open to ensure the vehicle is immobilized in driverless mode!

# Turning the Engine Off

To turn off the vehicle engine:

1. Disengage from driverless mode (Page 19).
2. Push the Engine Start / Stop button until "OFF" is illuminated in the button shown in the picture on the right.

If the Engine Start / Stop Button does not turn off the vehicle:

- 🚗 Ensure the vehicle is disengaged from driverless mode (Page 19).
- 🚗 Cut the 12 V cut loop to disable propulsion system (Page 25).



# Opening the Trunk

## To access the trunk:

1. Disengage from driverless mode or autonomous driving mode (Page 19).
2. Press the trunk release button on the front row overhead console, by the trunk door, or pull the exterior handle on the trunk.



# Towing a Tensor Gen5 Vehicle

Tensor roadside assistance team will be nearby in the event of a disabled vehicle and will coordinate and facilitate the retrieval. If needed, the Tensor vehicle can be towed like conventional front wheel drive vehicles (on a flatbed using standard wheel dollies on rear wheels).

If the parking brake cannot be released or a dolly tow with front wheels off the ground is not available, the vehicle should be placed on a flatbed truck for removal. Please use caution to avoid damaging sensors if possible.



4

# Base Vehicle Safety Emergency Response Guide

# Procedure to Disable 12 V and High Voltage (HV) Power

## The vehicle contains two 12 volt batteries:

- 🔌 One of the 12 V power is supplied by the Pacifica base vehicle's 12 V battery.
- 🔌 An additional independent 12 V battery serves as a redundant power source for the components of the Tensor autonomous driving system.
- 🔌 Both 12 V batteries can be accessed from the trunk.

## The vehicle contains one high voltage (HV) power:

- 🔌 The vehicle's HV battery system powers the hybrid propulsion motor as well as the Tensor autonomous driving system.
- 🔌 The HV battery can be accessed from the vehicle bottom.

## To disable electric power:

- 🔌 See Page 25-29 to disconnect the base vehicle's 12 V battery and disable the HV battery.

### NOTE:

Turn off Ignition switch by pressing the stop button, this will start the process of disabling 12 Volt and HV power. Remove the key fob and relocate it at least 20 feet away from the car.

- 🔌 Alternatively, if not able to do the steps on Page 26 to disable low voltage, or in addition to, if possible to perform safely – see Page 29 to disable HV power using the Service Disconnect.

# Disconnecting the Base Vehicle 12 V Low Voltage Battery

Physically cut the 12 V power from the vehicle, this will disable 12 V and HV power external of the HV battery.

## To cut the 12 V Cut Loop:

1. Under the hood, on the driver side towards the rear of the engine bay, remove the PDC (“fuse box”) cover.
2. Cut and remove a segment of the 12 V positive supply cable.
3. Attached near the front inner corner terminal of the PDC (“fuse box”).
4. Protect the cut ends of the positive cable from arcing against metal parts as the cable is live.

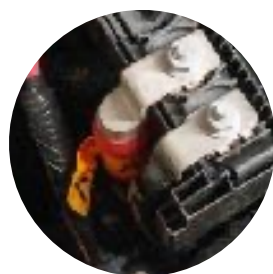
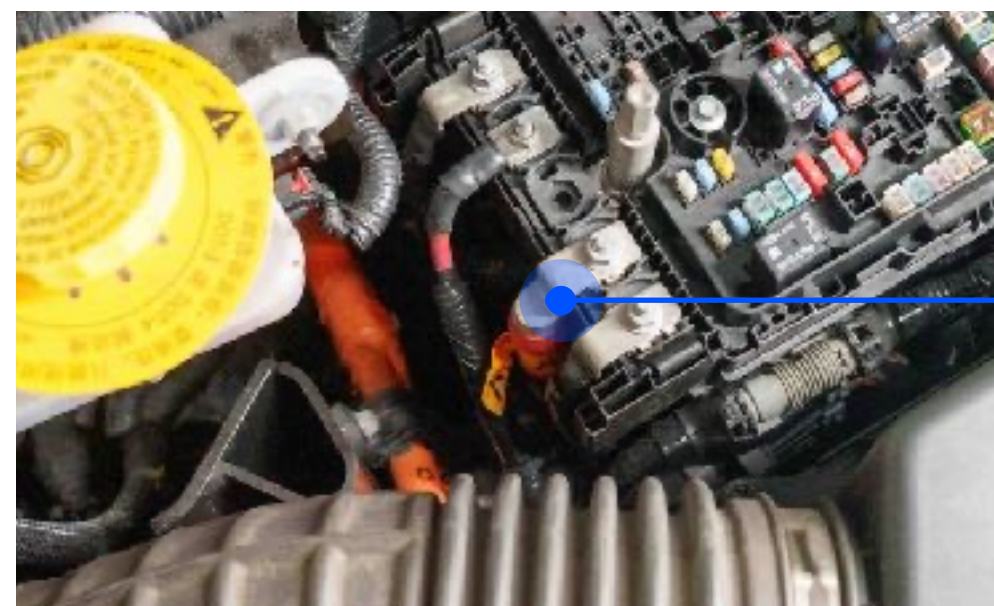

### Cut location

This step will disable both High Voltage Power and Restraint Systems

First responder cable cut loop tag in vehicle



### REMINDER

To prevent the vehicle from driving autonomously, keep at least one door open.

# Disconnecting Base Vehicle 12 V without Hood Access

If the vehicle is inverted or hood access is blocked, the base vehicle's 12 V battery can be disconnected at the battery, which is located in the trunk.

1. Turn vehicle off (Page 21).
2. Open rear trunk (Page 22).
3. Disconnect or cut and remove a segment of the base vehicle's negative battery cable shown on the right.

Base vehicle 12 V battery on the Tensor Pacifica vehicles

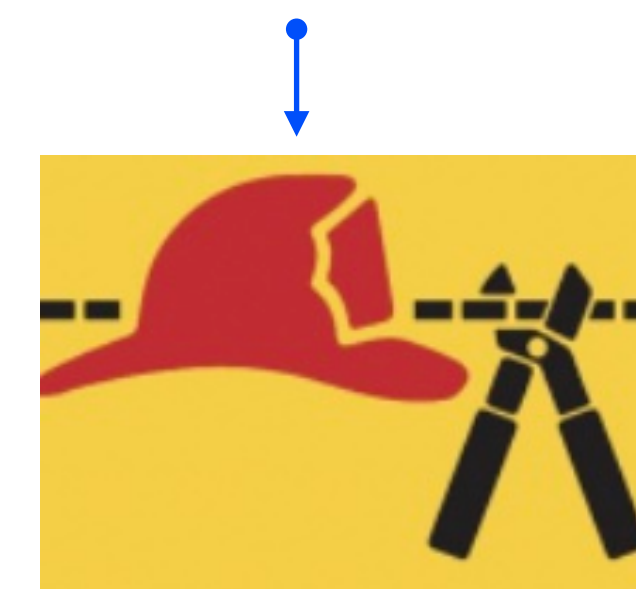
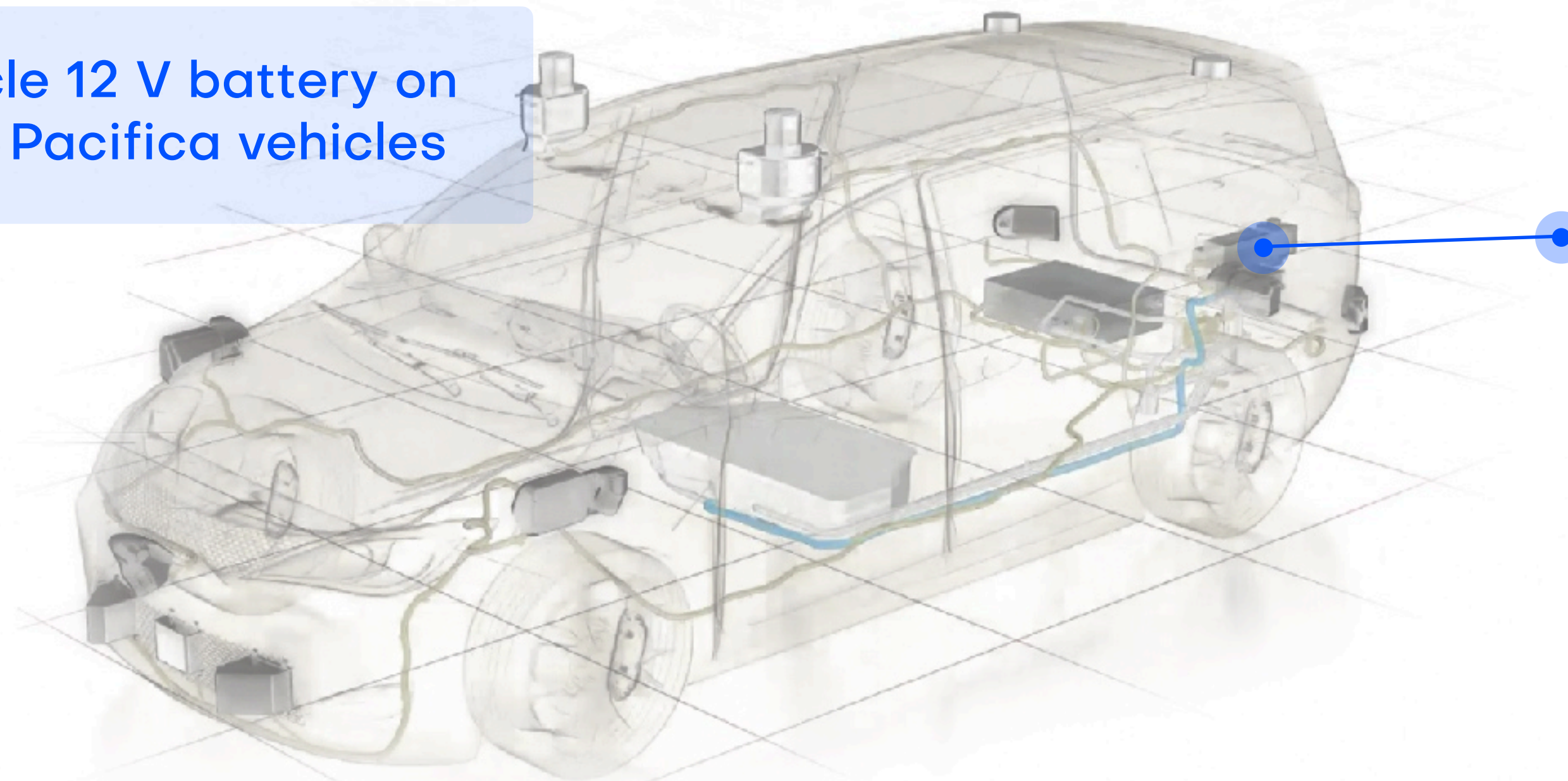

Cut location

# Disconnecting the Additional 12 V battery

An additional 12 V battery (redundancy power supply) for powering the Tensor autonomous driving system is located in the trunk. To disconnect this battery:

To disconnect this battery:

1. Open the rear trunk (Page 22).
2. Disconnect or cut and remove a segment of the negative battery cable as shown on the right.

## NOTE:

Disconnecting this battery does not disable HV power or 12 V power to airbags.

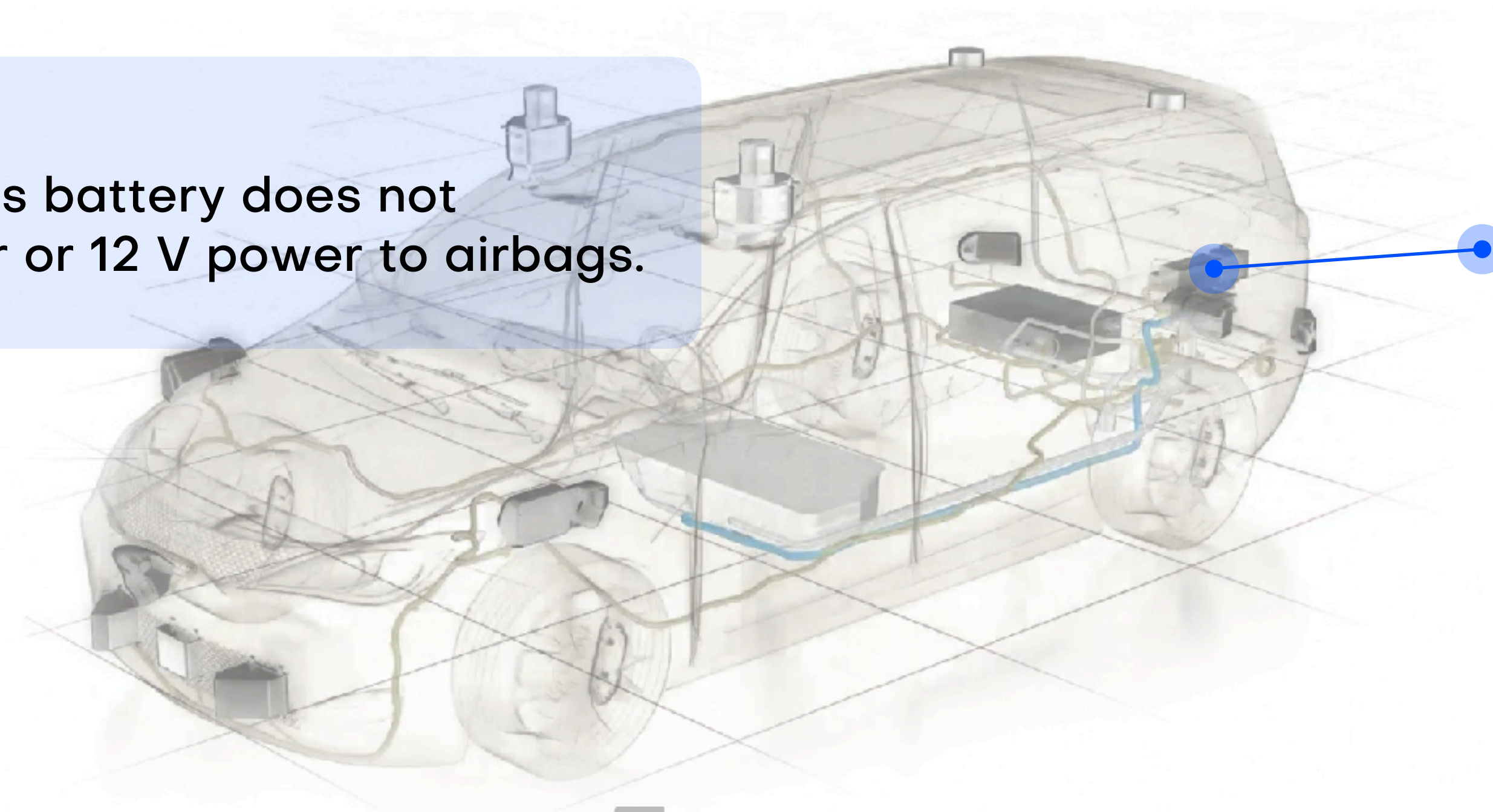

Isolated 12 V battery



Cut location

# Disabling high voltage output from the HV battery

## Emergency disabling of 12 V and High Voltage power

Removing the Service Disconnect will disable HV output from the HV battery system.



1. Uncover the Service Disconnect access cover located between the 1st and 2nd row seat.
2. Unbolt the cover panel over the Service Disconnect.
3. Remove the Service Disconnect.
4. Reinstall the cover over the empty socket and replace the carpet.

## Wait 5 minutes!

After completing the power-down steps above, wait 5 minutes before addressing a damaged vehicle. This will allow the HV capacitors to discharge under most circumstances. However, under some circumstances the HV Battery System HV Contactors may not open. Consequently, HV may not be contained to within the HV Battery System.



### REMINDER

Personal Protective Equipment (HV qualified Gloves, Boots and Coat) must be used by First Responders against Live HV.

# Extrication considerations

Impact event emergencies can require the extrication of victims from damaged vehicles. Determination of the need and timing to extricate must be made by incident command based on standard response practices and procedures.



## RECOMMENDED

If safe to do so, remove victims from an electrified vehicle, as risk of injury from HV battery degradation can increase over time.

## Potential HV electrical power system-related hazards to victims include:

- ⚡ Fire, which is sustained by heat from a damaged battery or shorted wiring.
- ⚡ Exposure to high voltage potentials caused by damage to the isolated HV system.
- ⚡ Carbon monoxide and hydrogen fluoride emissions from a thermally active damaged battery.
- ⚡ Potentially explosive hydrogen emissions from a thermally active damaged battery.
- ⚡ Unintended movement of the vehicle.



## RECOMMENDED

Decisions to extricate must take into account the balance between medical condition and hazard from the state of the vehicle.

Damage to fuel systems, hot coolant lines, all high voltage electrical components and cables, the batteries, and potentially active restraint systems must be avoided at all times. See the following pages for location information. (The “Do not cut” illustrations)

# Recommended Cut Points for Extrication

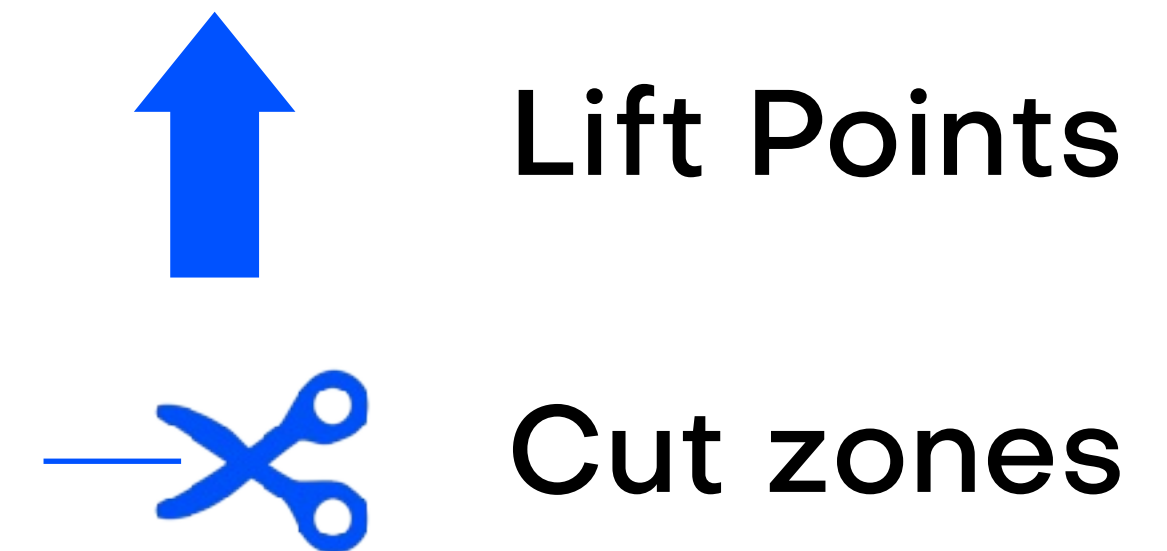
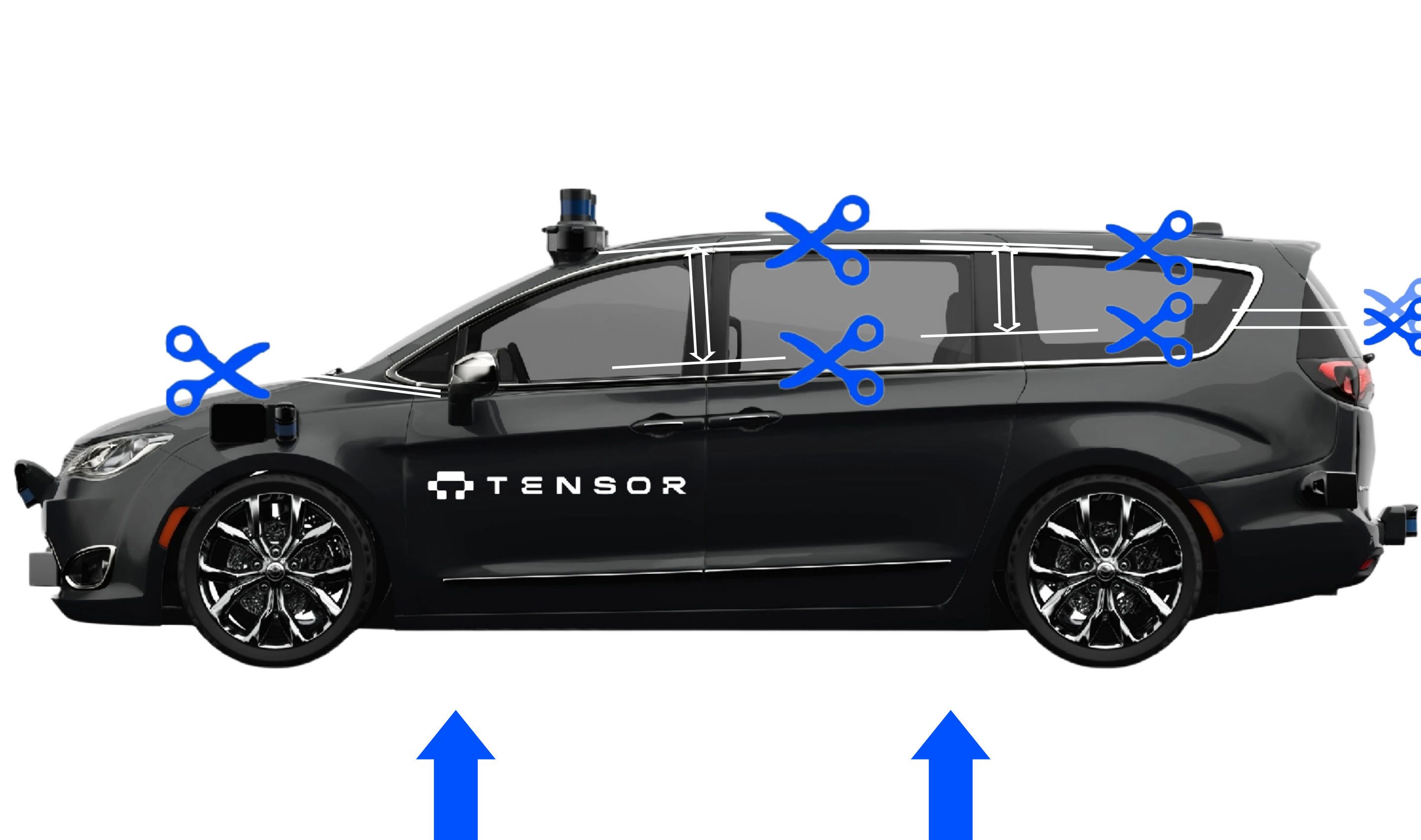

The areas illustrated between the scissor symbols are recommended cut zones on the vehicle. Determination of actual lift and cut points must be made by incident command based on the unique situational factors such as possible relocation of the hazards illustrated on the following pages as a result of impact events. These are only recommendations.

# Extrication Considerations for High Power Electrical Systems

High Power Electrical Systems

High Voltage Cables

High Voltage Components

High Voltage Battery

Low Voltage (12V) Battery and Cables

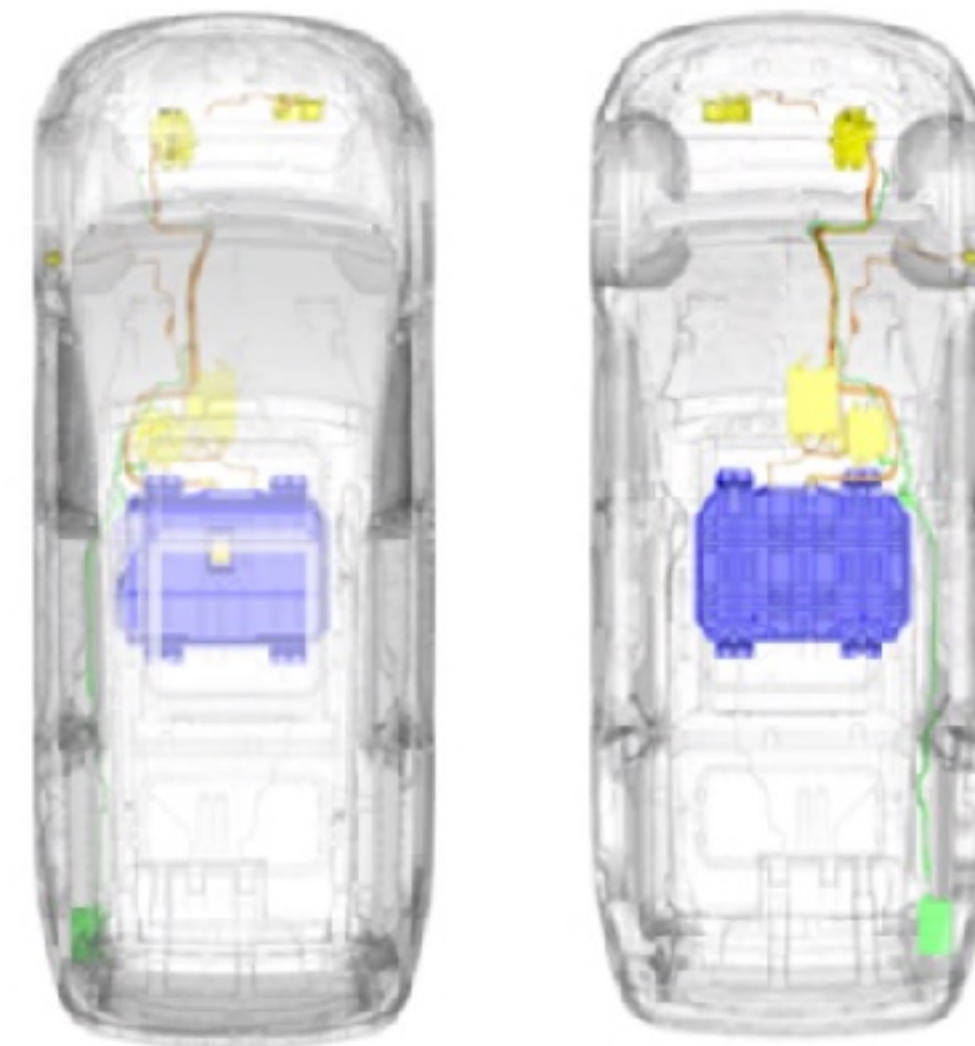
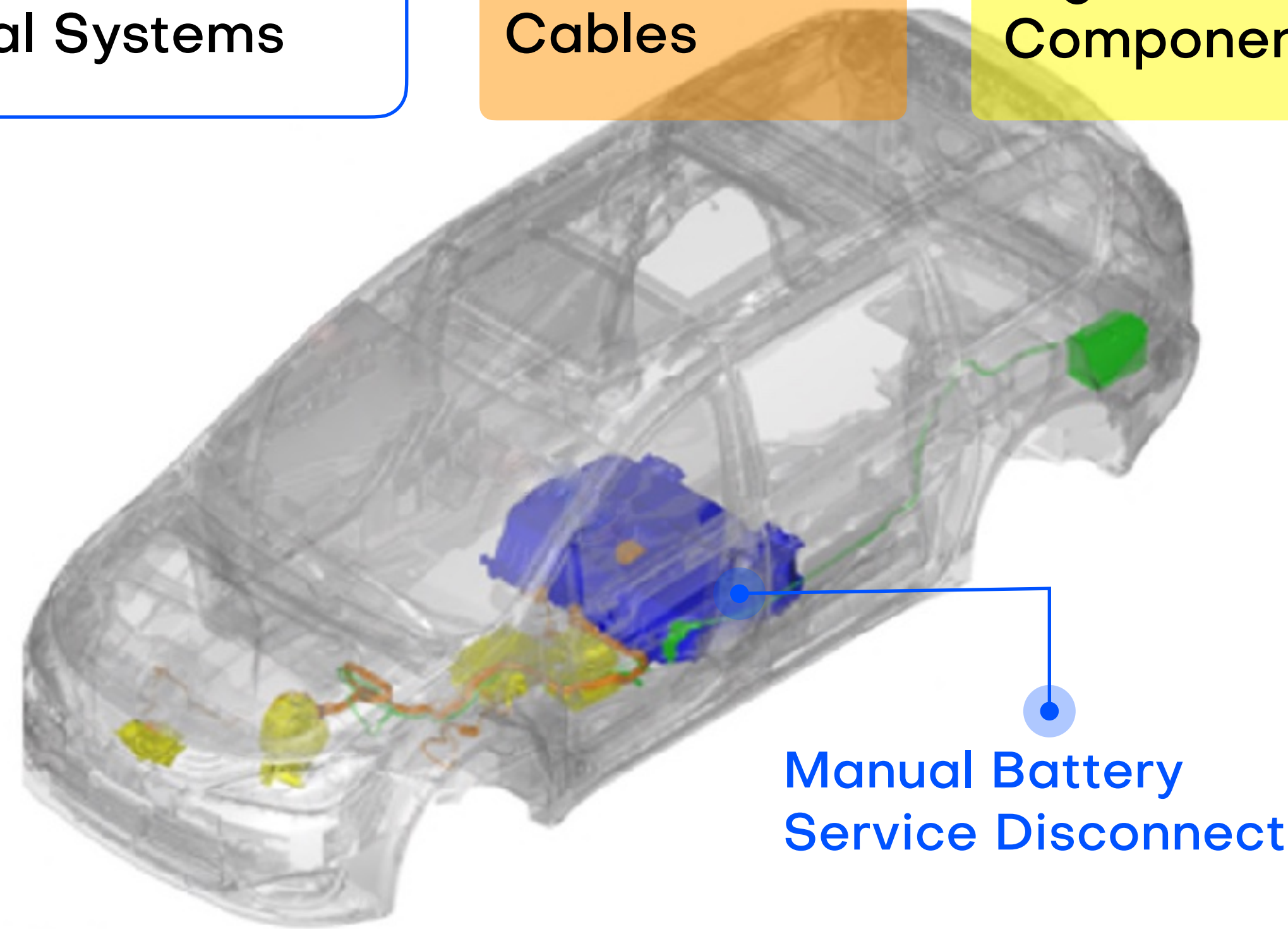

**WARNING**

**DO NOT CUT or pierce high voltage devices**

# Extrication Considerations for Fuel and other Fluid Systems

Fuel and other Fluid Systems

Gasoline Fuel Tank and Fuel Lines

Brake and Power Steering Reservoirs

Radiator and Cooling System

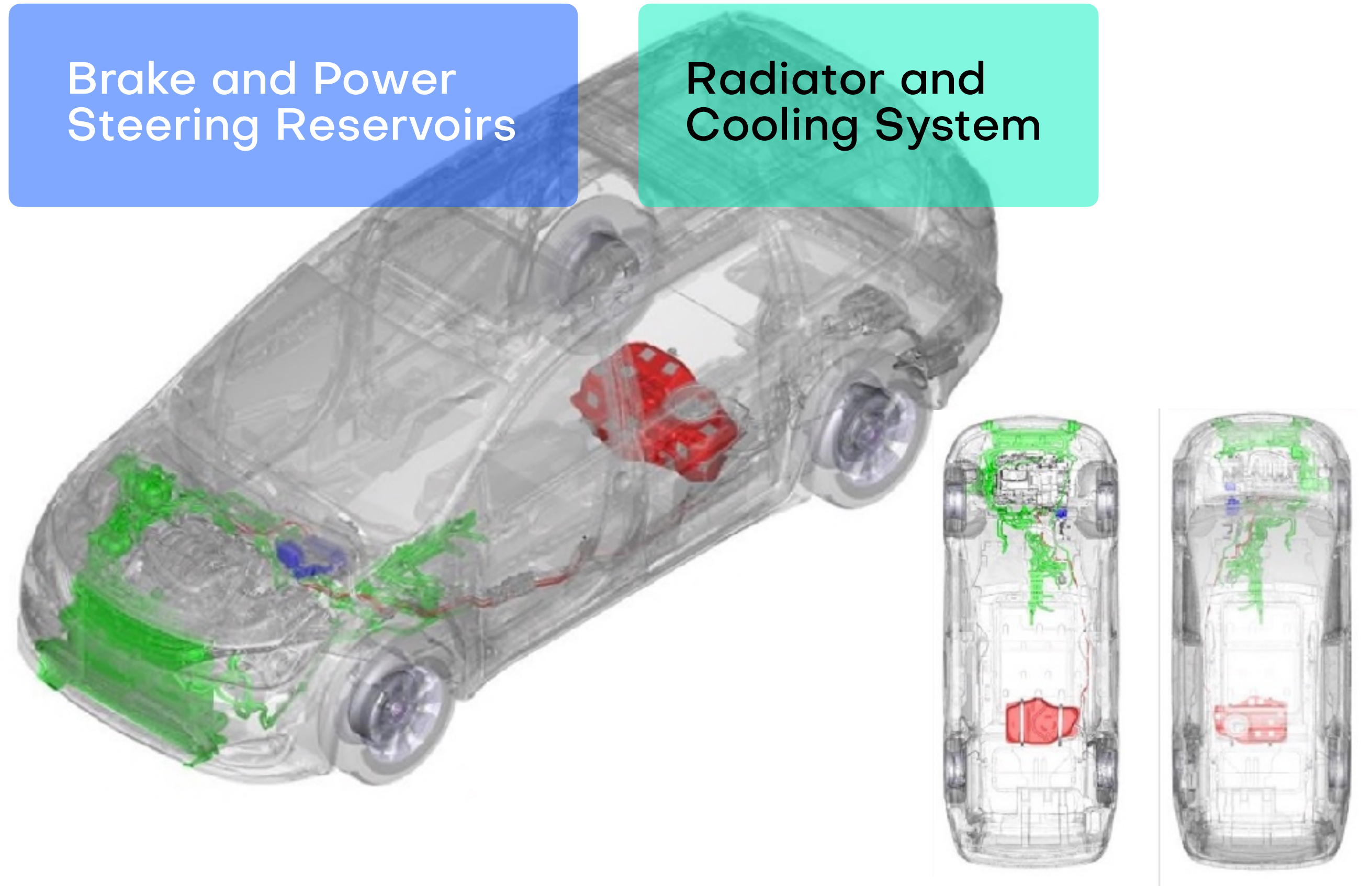

**!** WARNING

DO NOT CUT fuel tank, fuel or coolant lines

**!** WARNING

DO NOT CUT into any pressurized or combustible fluid component illustrated below

# Extrication Considerations for Restraint Systems

## Restraint Systems

Front seat belts with pretensioning devices (horizontal cylinder below the belt spool)

- Driver and front passenger airbags, seat-mounted side bolsters and leg bolsters
- Side curtain air Bags

## Impact sensors

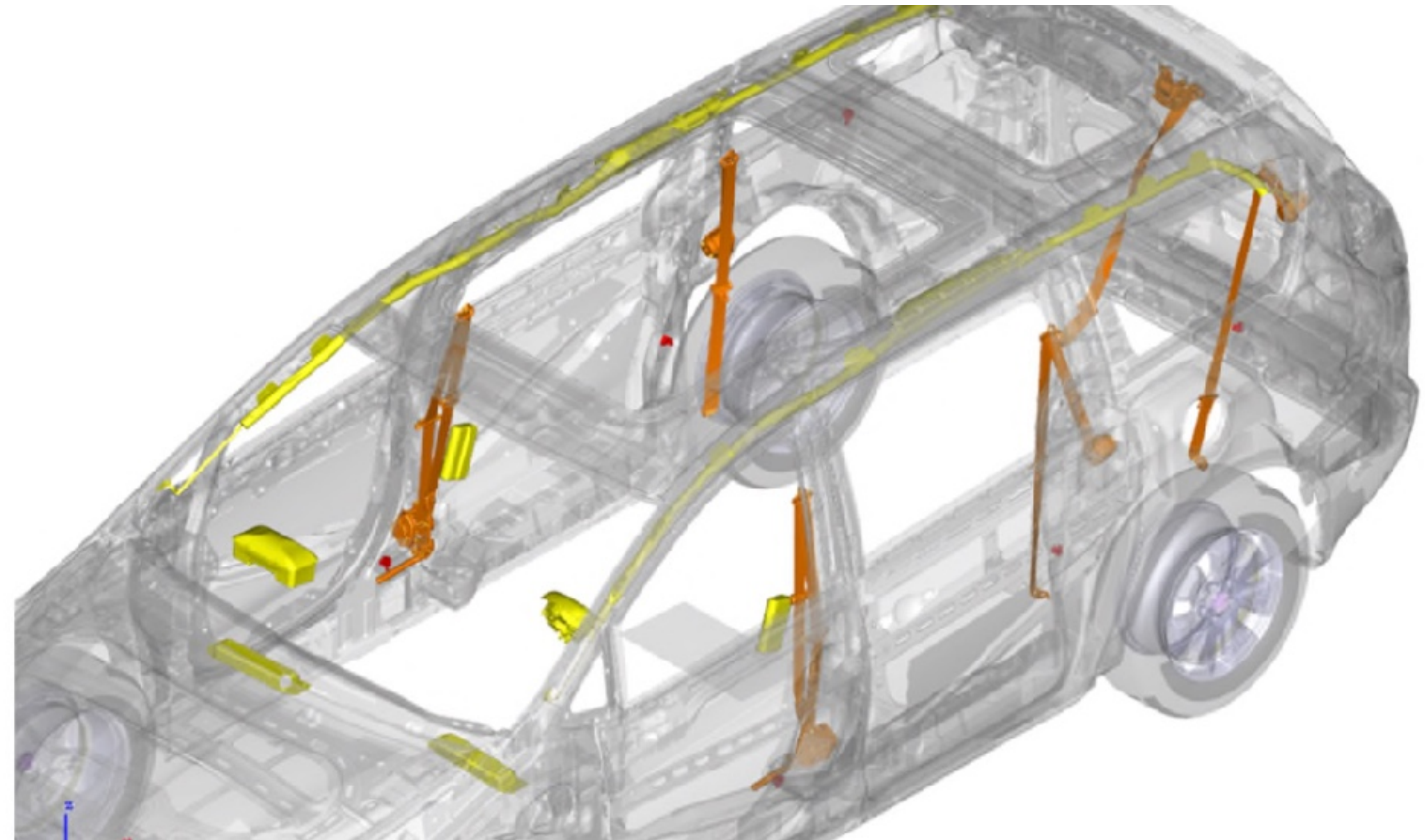

## WARNING

DO NOT CUT into occupant restraint components. (Fabric belts only may be cut with a knife)

# Extrication Considerations for Tensor Autonomous Driving System Electrical Considerations

## High Power Electrical Devices of the Tensor Autonomous Driving System

High Voltage Components & Cables

Low Voltage (12V) Batteries & Cables

### WARNING

Do not cut or pierce high voltage electrical devices.

### WARNING

In case of submersion, the HV devices of the autonomous driving system imposes an increased risk in electrical shock hazard. First responders should keep away from these HV devices in the trunk.

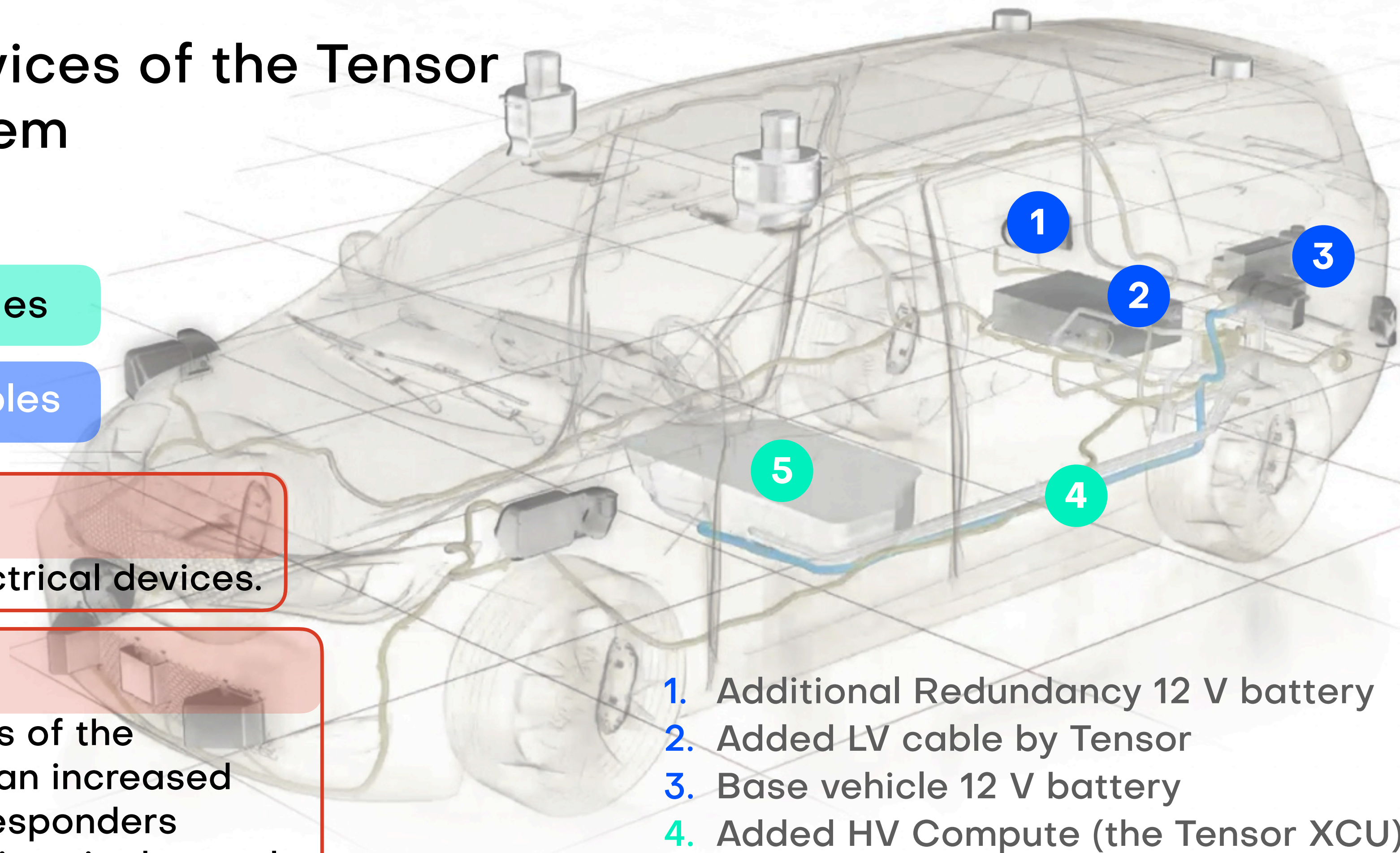

1. Additional Redundancy 12 V battery
2. Added LV cable by Tensor
3. Base vehicle 12 V battery
4. Added HV Compute (the Tensor XCU)
5. Base vehicle HV battery

# Extrication Considerations for the Tensor Autonomous Driving Cooling System



## WARNING

Avoid cutting autonomous driving coolant lines except when necessary.

A Coolant contains 50/50 Ethylene Glycol (Antifreeze) / Water and may be flammable at high temperatures.

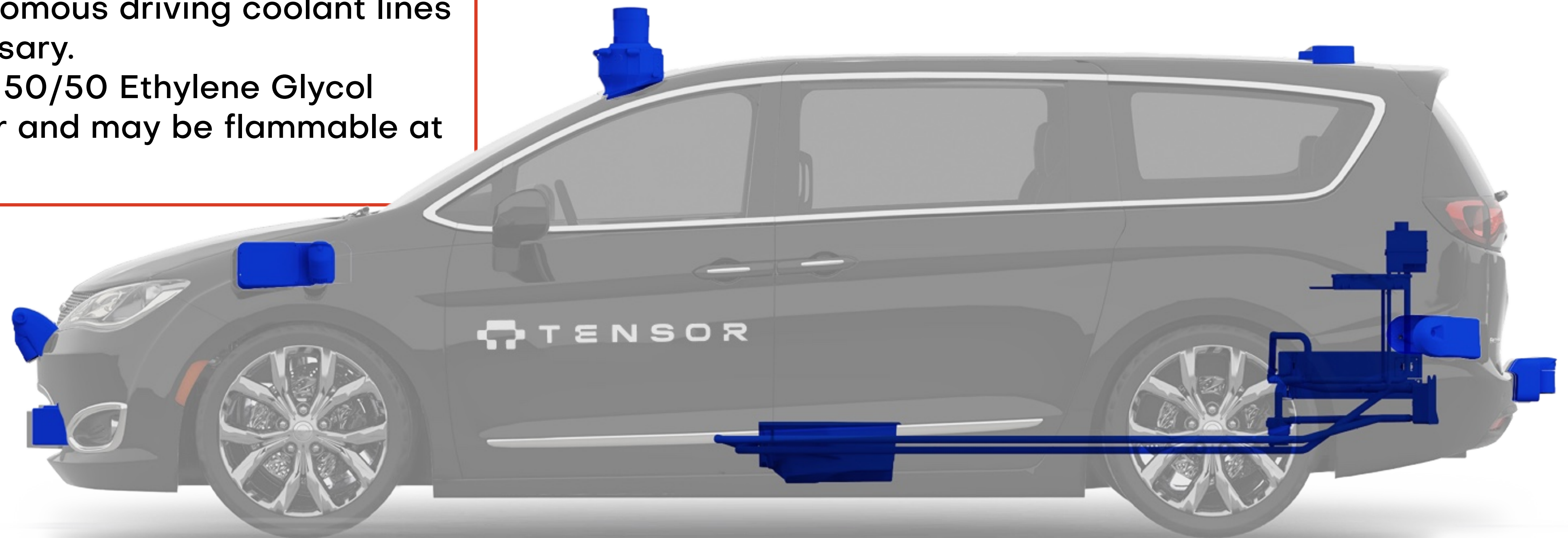

## Autonomous driving cooling system

Uses 50/50: Ethylene Glycol (Antifreeze) Water

# In Case of Fire

The Chrysler Pacifica Hybrid includes a high voltage lithium-ion battery system. As a result, special consideration must be given to extinguishing methods and practices.

- Chemical extinguishers and oxygen denial are not effective in these fires.
- Deluge with water delivered via fire hose at the maximum possible distance is the recommended practice to contain the fire and cool the reagents, minimizing risk of spread and risk of hazardous emissions. This should continue after extinguishment until the pack is cool.
- Ventilation of the passenger compartment, if occupied, is essential at the first sign of battery heating, smoke or fire.
- Batteries should be thermally assessed during initial operations and throughout rescue and remediation efforts.
- Damage, abuse, flooding or exposure to heat (such as from a vehicle fire) can initiate thermal reactions which will advance to a significant fire in lithium ion power systems.
- Lithium-ion automotive batteries can reignite due to ongoing reactions from internal heat.
- Continue after extinguishment until the pack is cool. The Battery thermal reactions become self-sustaining at higher temperatures due to the emission of oxygen from certain constituents.
- The Battery thermal reactions become self-sustaining at higher temperatures due to the emission of oxygen from certain constituents.
- Ongoing battery fire or heat production can facilitate the re-ignition of combustible automotive components above and adjacent to the pack.
- For any battery thermal event, NFPA recommends SCBA be required within fifty feet.

 **WARNING**

Never cut, pierce or damage any high voltage component as serious injury may result.

 **WARNING**

**WARNING:** Emissions from a thermally active lithium-ion battery include flammable hydrogen, and hydrogen fluoride which when combined with moisture in the human body forms an acid that can cause tissue burns, respiratory distress and injury, blindness and/or death.



# Post-incident handling

Following initial response, certain actions and precautions are necessary. If air bags have deployed, the vehicle cannot be driven again until repaired, as air bag protection will not be available to occupants in the event of a collision. After any collision, the vehicle should be taken to an authorized dealer immediately.

While the Chrysler Pacifica Hybrid HV battery is designed for safety, industry-wide experience has demonstrated that the unlikely possibility of delayed ignition or re-ignition of a damaged battery must be considered in post-incident handling. Any battery exposed to accident forces sufficient to deploy air bags or to a vehicle fire requires special precautions until verified as undamaged.

- 🚗 The vehicle or battery pack must not be stored inside a structure, occupied or otherwise.
- 🚗 Adequate ventilation must be present at the storage location to prevent buildup of any outgassing.
- 🚗 Batteries to be recycled must be shipped in accordance with regulations governing the transport of damaged lithium-ion batteries (and never by air).
- 🚗 Thermal monitoring of any damaged, flooded or burned battery should be performed during storage.
- 🚗 The manual battery Service Disconnect must not be reinstalled by other than an authorized technician.
- 🚗 The Service Disconnect socket must be covered/sealed to prevent water or debris entering the battery. water or debris entering the battery.
- 🚗 The battery pack in this vehicle uses non-spillable lithium-ion cells, and it is unlikely that electrolyte, which is clear, will escape from the pack in the event of damage. Liquid emissions from damaged packs are typically colored battery coolant, which should be addressed in the same manner as spilled engine coolant.
- 🚗 Do not apply chemical neutralizers used for other battery types to lithium-ion battery components, or take any other action which could result in battery cell contents being aerosolized.