



STREET CO'
DISPLAY SOLUTION EXPERT

InnoPad INNOVATIVE FLEXIBLE LED



2023 version

08

Specifications

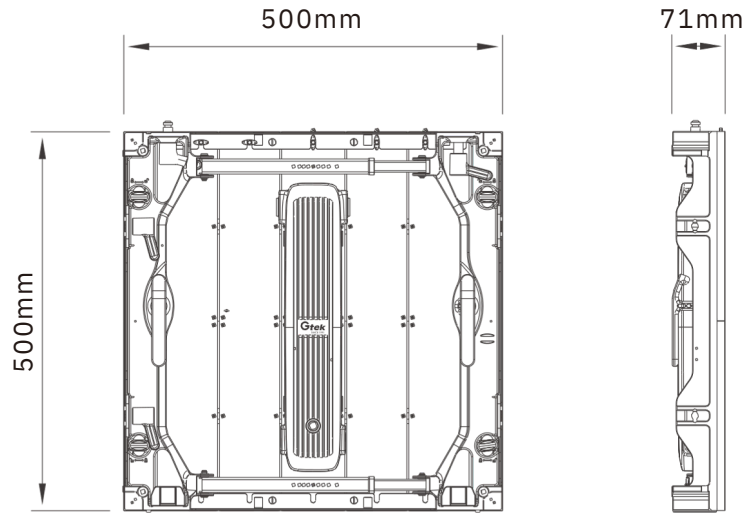

Product Name		InnoPad	
Product model	C1.9TCC2.6TC		C2.9TC
Pixel pitch	1.9mm/2.6mm		2.9mm
Pixel density/m	262/144/147/456		112896
Brightness	800nit/1000nit		1000nit <
Weight	<7Kg/tile (15.4LB/tile)	<7Kg/tile(15.4LB/tile)	7Kg/tile(15.4LB/tile)
Module size	500*500mm		
Panel size	500*500*71mm (19.69*19.69*2.80in)		
Ingress protection	IP30		
LED type	SMD		
Viewing angle	160 /160		
Processing depth	16bit		
Contrast ratio	10000:1		
Date refresh rate	3840Hz		
Power consumption (Max/Avg.)	380/120W/m		

※LCD indicator screen is optional, please refer to the actual shipment inspection report.