

Uslim

Innovative and Flexible LED signage solution



STREET CO'
DISPLAY SOLUTION EXPERT
www.streetcommunication.com

www.streetcommunication.com

Content

01

Uslim Features

02

Certification and Test

03

Packing

04

Applications



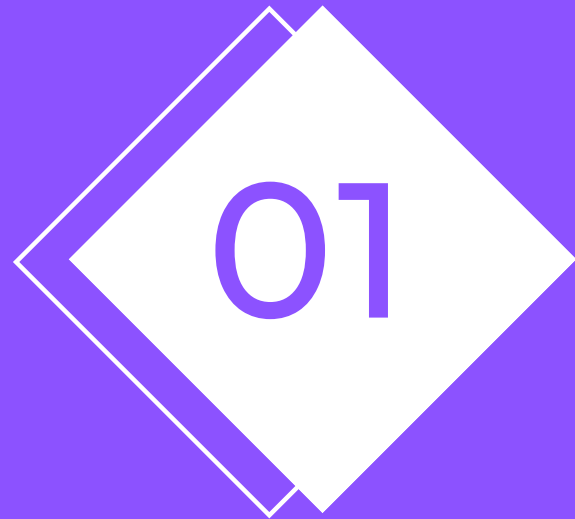

Uslim Features



Advantages

01

Series Design

02

Convenient
Maintenance

03

Convenient
Mounting

04

Die-casting

05

Patent Design

06

Fan-less and
Noiseless

07

Detail Design

08

Multiple Backup



Series Design

- Series size design——500*1000 & 500*500
- Series pixels pitch design ——1.9~6.9mm
- It can use the same series to match various kinds of pixel pitch projects. Technicians can easily install and maintain the product in different projects. **Saving training.**
- Drawing sharing. There is no need to design again. And it's easy to check the drawing. **Saving design.**
- Any success project can become an advertisement to help other pitches' products to sale better. Saving advertisement.
- Spare part can be managed together. **Saving management.**



Convenient Maintenance

- Indoor series can full front and rear maintenance about receiving card, power supply and module.



Convenient Maintenance

- Indoor module with pop-up design for front service.
- With sound effect, strong interaction and patent protection.



Convenient Mounting



Wall-mounting

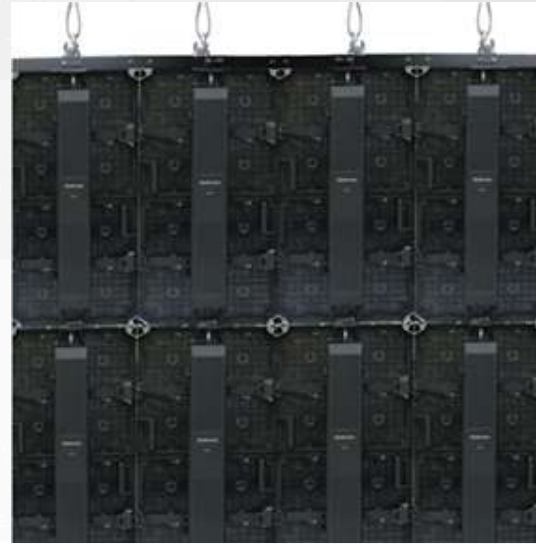

Hanging

Stacking



Die-casting Aluminum cabinet

- High-precision panel
- Enhance panel strength and reduce the requirement for steel structure.
- High efficiency heat dissipation
- High ingress protection

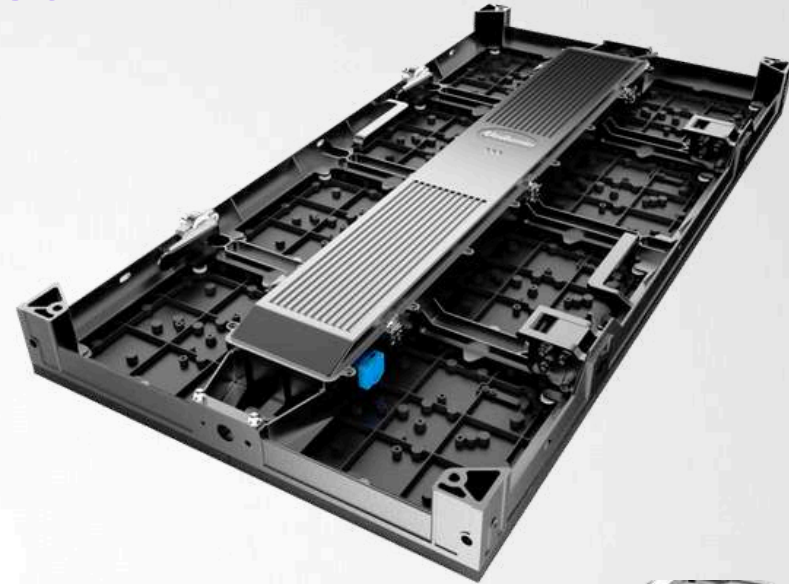

Patent design

Independent R&D, patent protection

- Pop-up mechanical design
- Appearance patent
- Hanging lock



Fan-less and noiseless



Detail design

- Back plate design for heat dissipation
- Indicator and test button
- Handle design of the cabinet

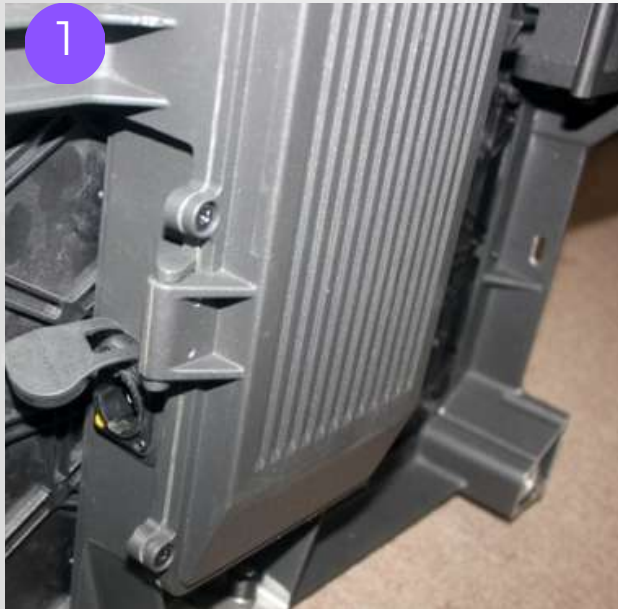

Detail design

- Lamp protection design, keep the LEDs 2mm above the platform. Prevent LED collision during cabinet placement

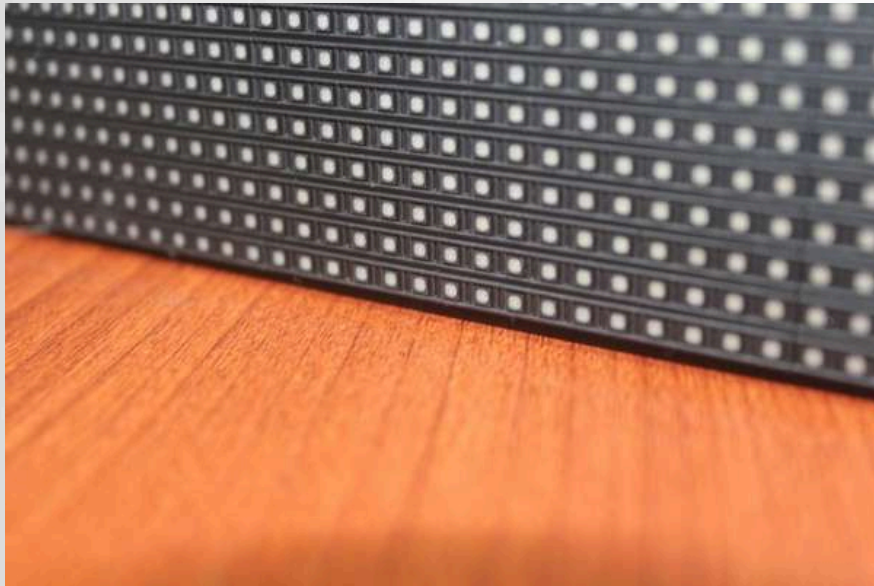

Multiple Backup Indoor

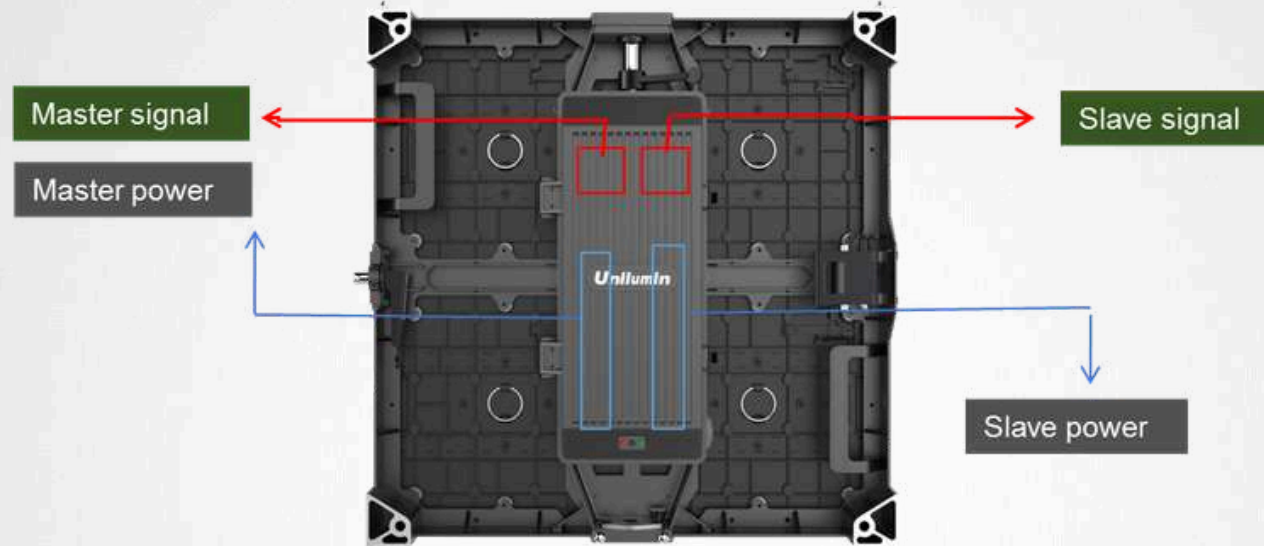

- Multiple backup :
- Dual power supply backup, dual receiving card backup
- Dual power supply backup :
- If one supply is down, the other supply still keeps the screen working properly
- Dual receiving card backup :
- If one receiving card is down, the other receiving card still keeps the screen working properly

Specifications

Parameter		indoor		
Pixel Pitch	Uslim 1.9	Uslim 2.6	Uslim 3.9	Uslim 4.8
Panel Size (mm)	W500 × H500 × D83	W500 × H500 × D83 / W500 × H1000 × D83		
Brightness (cd/m ²)	600	900	900	900
Material	Die-casting Aluminum			
Weight (kg/panel)	7.8	7.8 / 13	7.8 / 13	7.8 / 13
Maintenance Method	Front and rear maintenance			
Contrast Ratio	3000:1			
Protection Level	IP30			
Input Power (Max) (w/panel)	120	120 / 240	120 / 240	120 / 240
Input Power (Typical) (w/panel)	40	40 / 80	40 / 80	40 / 80
Application	Retail store, Cinema, Church, Corporate, Gas station, Airport, Transportation, City board, etc.			



Certification and Test



Certificate

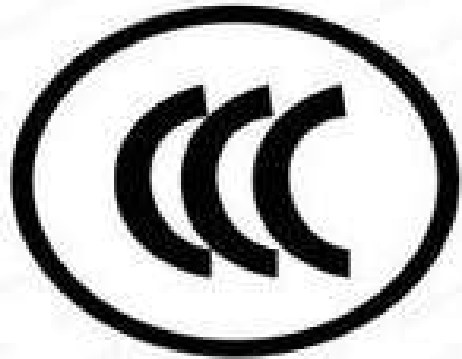

Support global market requirement

Waterproof Test of Outdoor Series

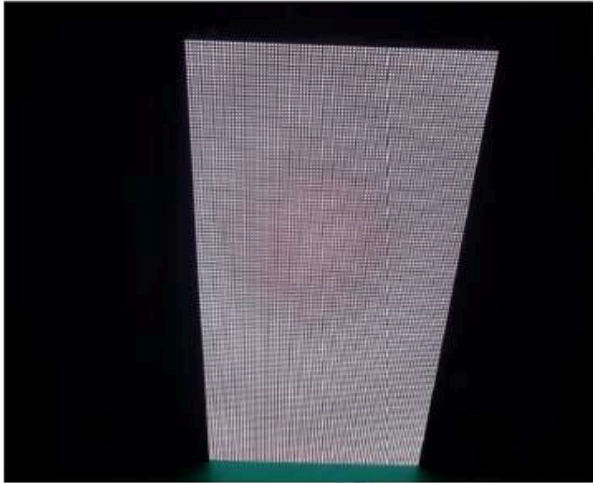
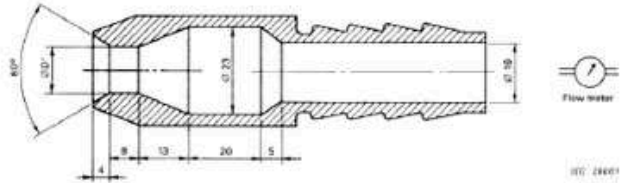

Fig.3 Function check before testing



Fig.4 IPX5 testing (rear side)

Test Result

IPX5 TEST	<input type="checkbox"/> Fail <input checked="" type="checkbox"/> Pass
Test condition: <ul style="list-style-type: none"> — Internal diameter of the nozzle: 6.3 mm; — Flow speed: 12.5L/min\pm5%; — Water pressure: adjust to provide designated flow rate; — The actual water column size: approximately 2.5 meters away from the nozzle in the position of about 40 mm in diameter — Every square metre cabinet surface area may be spitting testing time: 1min; — The shortest test last time: 3 minutes; — From the nozzle to the surface of the cabinet distance: between 2.5 meters to 3 meters. 	
Nozzle for test: Figure  <p style="text-align: right;">FIG. 24001</p> <p style="text-align: center;">Dimensions in millimetres</p> <p>$\phi = 6.3$ for the test of 14.2.5 (second characteristic numeral 5) $\phi = 12.5$ for the test of 14.2.6 (second characteristic numeral 6)</p>	

Conditions for acceptance	Result
Interference with correct functioning of the appliance or impair safety	OK
Deposit on insulation parts where it could lead to tracking along the creepage distance or reach live parts	Ok
Accumulate near cable end or enter the cable	Ok
If with drain-holes, any water which entered shall not accumulate and drains away without doing harm to the appliance	N/A



Packing



Packing

Wooden case



Flight case





Applications



Retail



Uslim3, 3.75sqm, Sephora Senayan City,
Indonesia, 2018



Uslim2, 12sqm, Senayan City,
Indonesia, 2018

Exhibition



Uslim2 , 500sqm , New World Shopping Center, South Korea

Airport



Uslim2.6, 30sqm, Djakarta Airport, Indonesia



Uslim3.9, 20sqm, Haugesund Airport, Norway

Palladium Theatre



Uslim2.6, Semi outdoor, 6sqm, Palladium Theatre,
London